



US00D920666S

(12) **United States Design Patent** (10) **Patent No.:** **US D920,666 S**
Lederer (45) **Date of Patent:** **** Jun. 1, 2021**

(54) **SUITCASE**

D858,986 S * 9/2019 Shalgi D3/279
D861,341 S * 10/2019 Xu D3/279
2013/0319808 A1* 12/2013 McClure A45C 9/00
190/1

(71) Applicant: **RTL Group Investments Pty Ltd,**
Bellevue Hill (AU)

(Continued)

(72) Inventor: **Robert Lederer,** Bellevue Hill (AU)

Primary Examiner — Lilyana Bekic

(73) Assignee: **RTL Group Investments Pty Ltd,**
Bellevue Hill (AU)

Assistant Examiner — Mary Shannon Malley

(74) *Attorney, Agent, or Firm* — Banner & Witcoff, Ltd.

(**) Term: **15 Years**

(57) **CLAIM**

The ornamental design for a suitcase, as shown and described.

(21) Appl. No.: **29/633,251**

(22) Filed: **Jan. 12, 2018**

DESCRIPTION

(30) **Foreign Application Priority Data**

Jul. 13, 2017 (AU) 201714226

(51) **LOC (13) Cl.** **03-01**

(52) **U.S. Cl.**
USPC **D3/279**

(58) **Field of Classification Search**
USPC D3/273, 276, 279, 282, 289, 290, 301,
D3/318, 902; 190/115, 18 A
CPC A45C 5/00; A45C 5/03; A45C 5/14; A45C
2003/008; A45C 2005/032; A45C
2005/035; A45C 2005/037
See application file for complete search history.

FIG. 1 is a front perspective view of a suitcase showing my new design;

FIG. 2 is a rear perspective view thereof;

FIG. 3 is a front view thereof;

FIG. 4 is a rear view thereof;

FIG. 5 is a top view thereof;

FIG. 6 is a bottom view thereof;

FIG. 7 is a left side view thereof;

FIG. 8 is a right side view thereof;

FIG. 9 is an enlarged view of the area within the broken line rectangle identified by reference numeral 9 in FIG. 8;

FIG. 10 is a front perspective view of the suitcase of FIGS. 1-9 with the handle shown in an extended position; and, FIG. 11 is a rear perspective view of the suitcase of FIGS. 1-9 with the handle shown in an extended position.

The dot-dash broken lines at the bottom of the handles on the top and side of the suitcase represent boundary lines and form no part of the claimed design. The even-length dash broken line rectangle labeled by numeral 9 in FIG. 8, and the even-length dash broken line rectangle surrounding the enlarged region in FIG. 9, define the bounds of the enlargement and form no part of the claimed design. The even-length dash broken lines depicting the remaining portions of the suitcase form no part of the claimed design.

(56) **References Cited**

U.S. PATENT DOCUMENTS

D428,698 S * 8/2000 Cheng D3/276
D438,005 S * 2/2001 Tiramani D3/273
D675,016 S * 1/2013 Van Overbeke D3/273
D714,057 S * 9/2014 Hou D3/279
D722,771 S * 2/2015 Wu D3/279
D772,571 S * 11/2016 Sijmons D3/279
D785,937 S * 5/2017 Morszeck D3/279
D788,460 S * 6/2017 Morszeck D3/279
D793,086 S * 8/2017 Mahanavanont D3/279

1 Claim, 11 Drawing Sheets

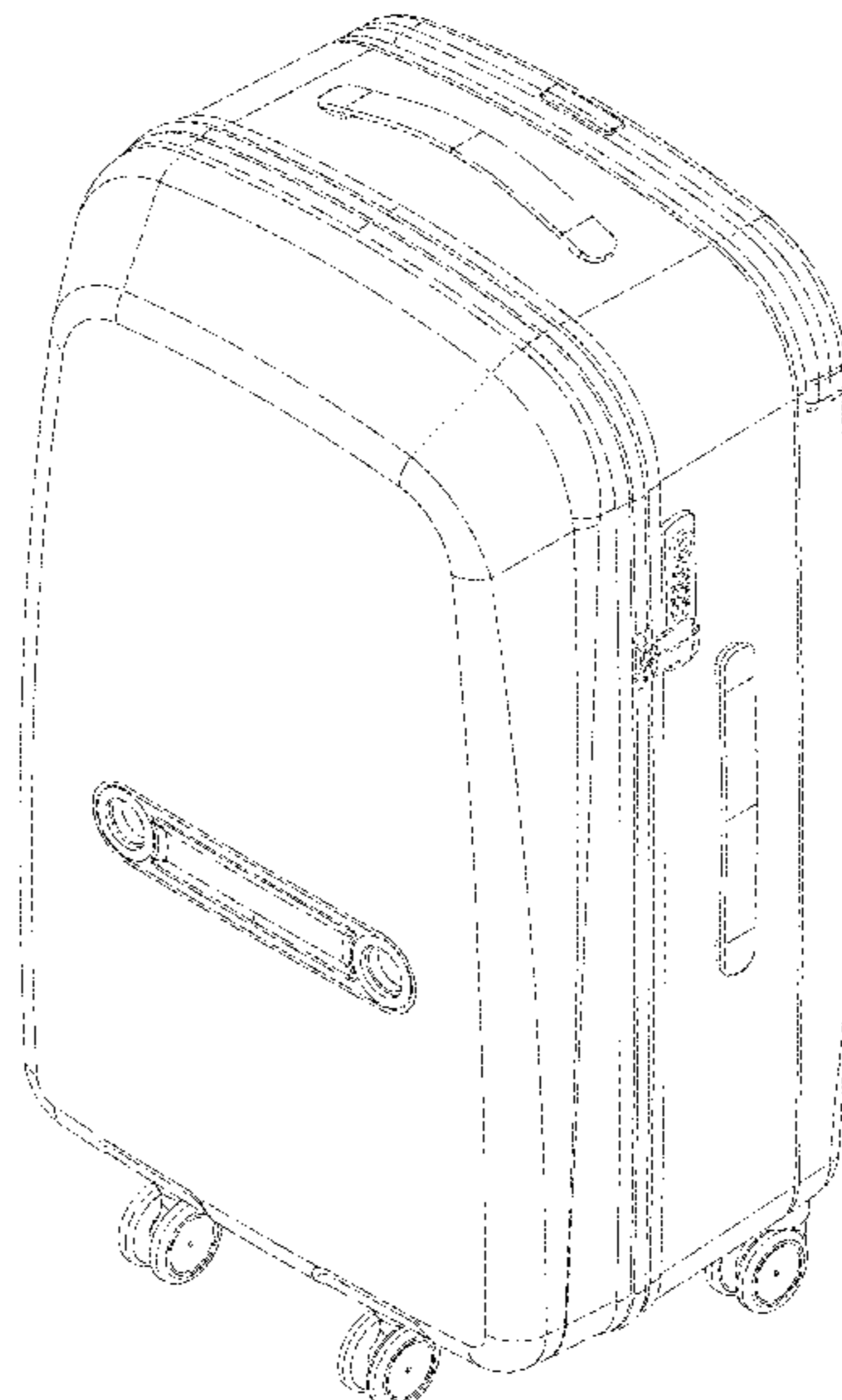

(56)

References Cited

U.S. PATENT DOCUMENTS

2015/0150348 A1* 6/2015 Wax A45C 5/03
190/18 A

* cited by examiner

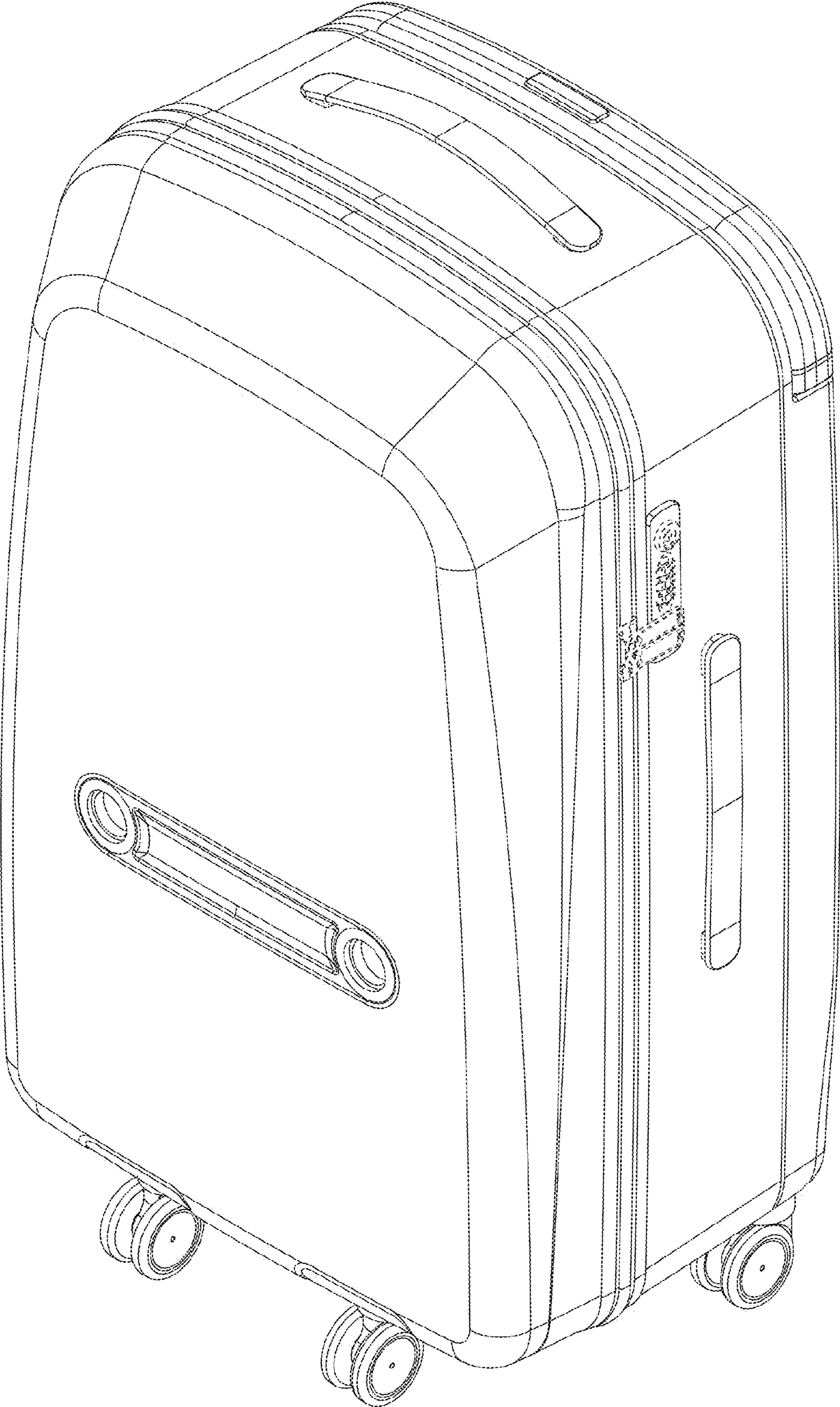

FIG. 1

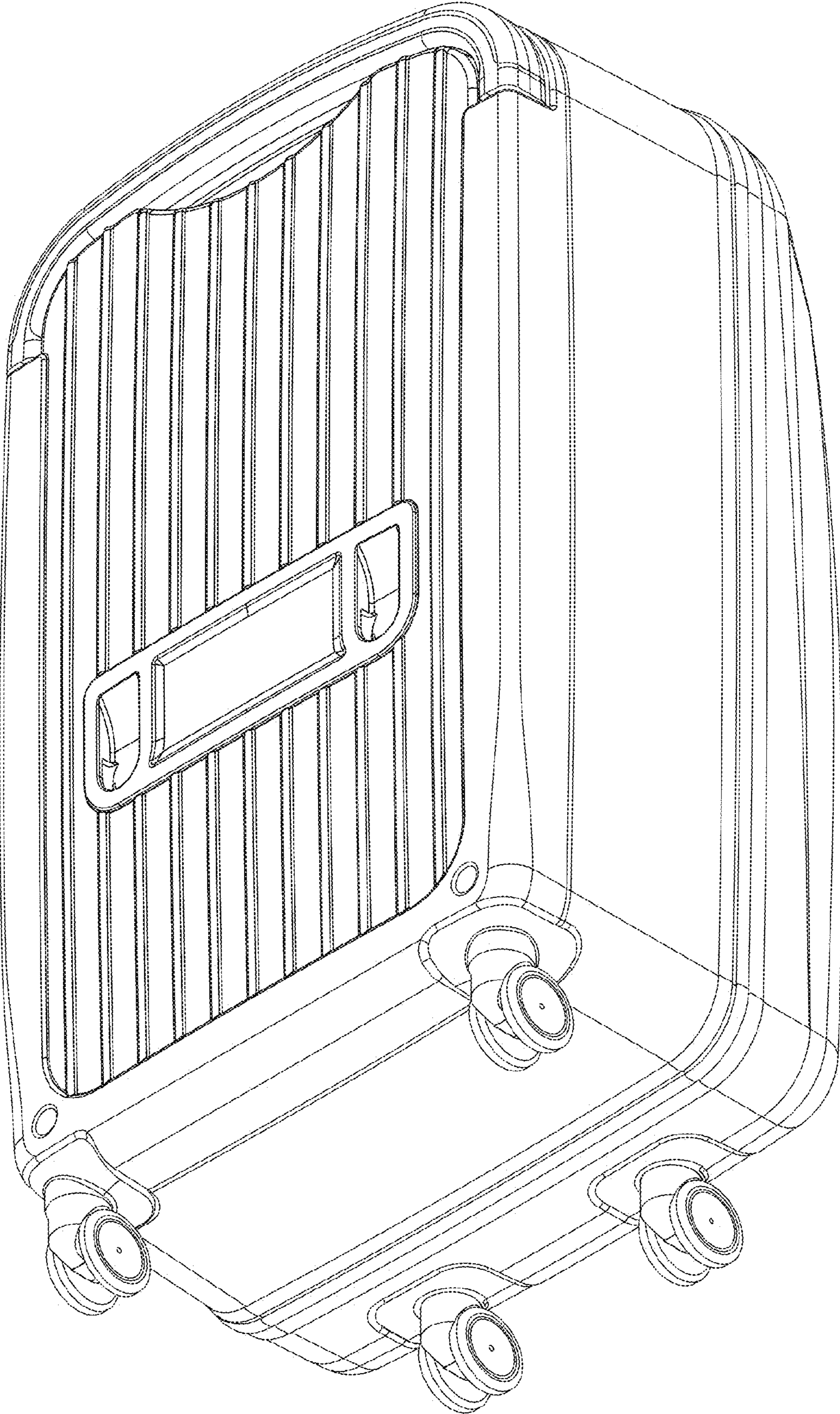

FIG. 2

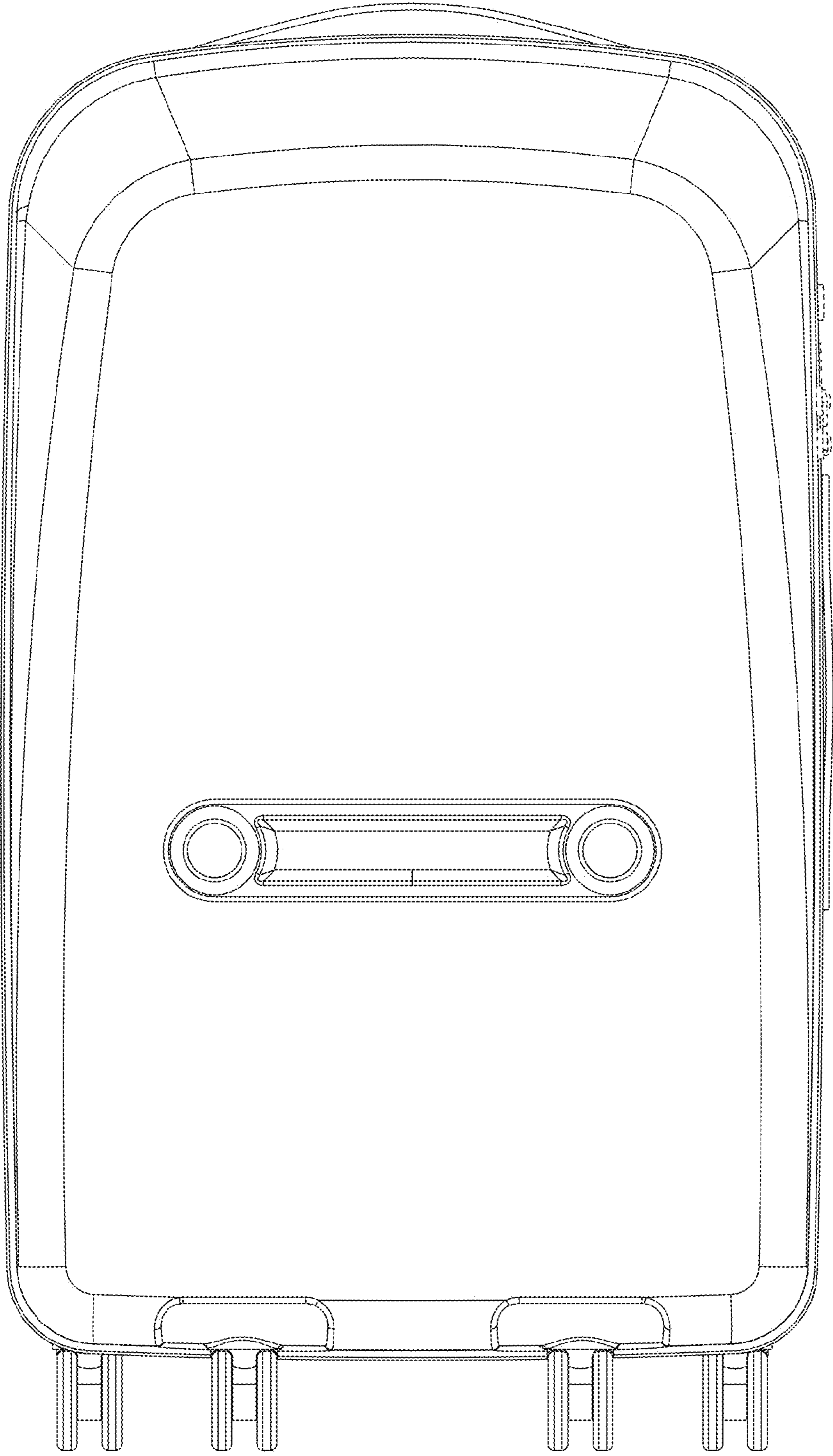

FIG. 3

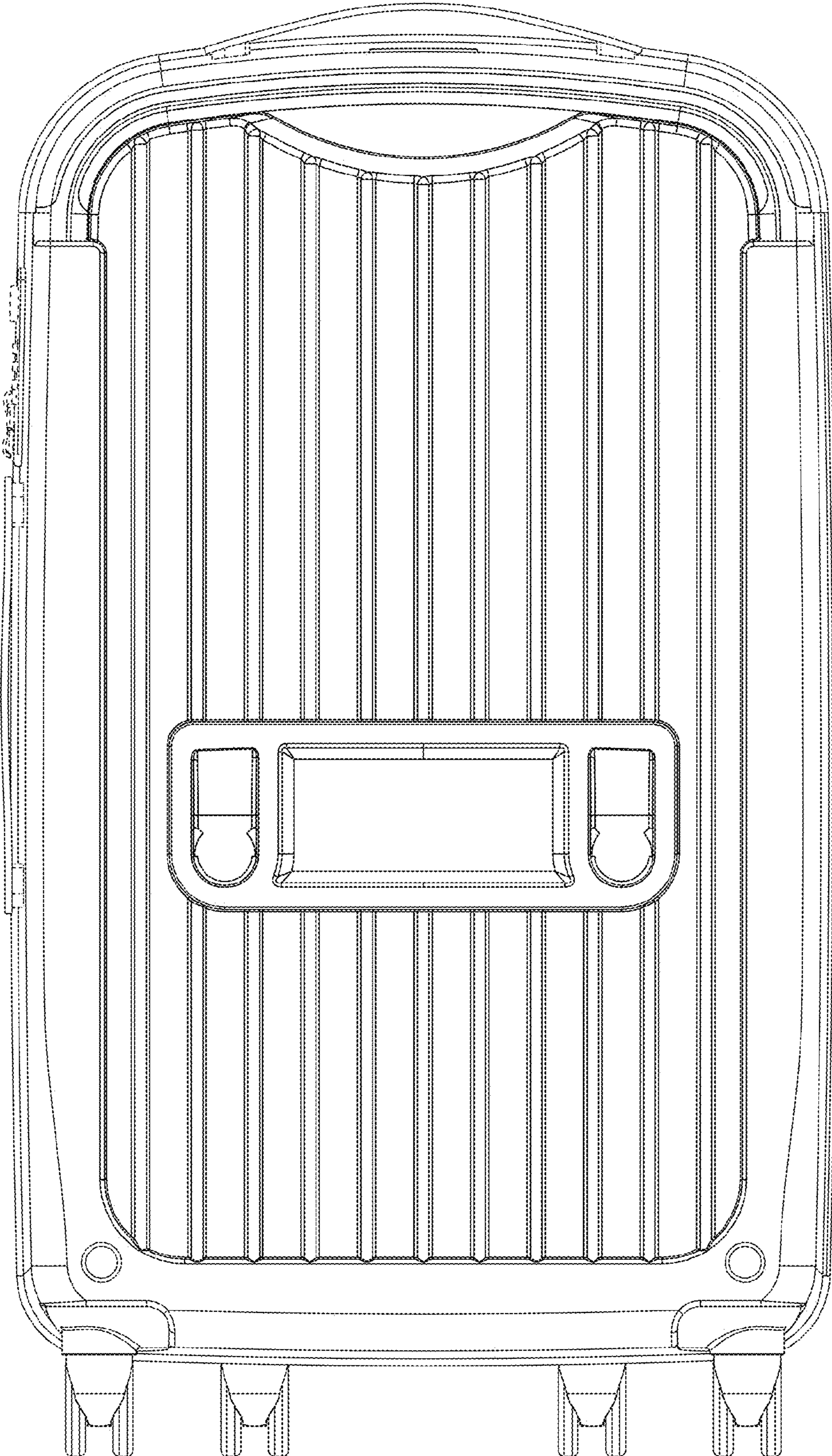

FIG. 4

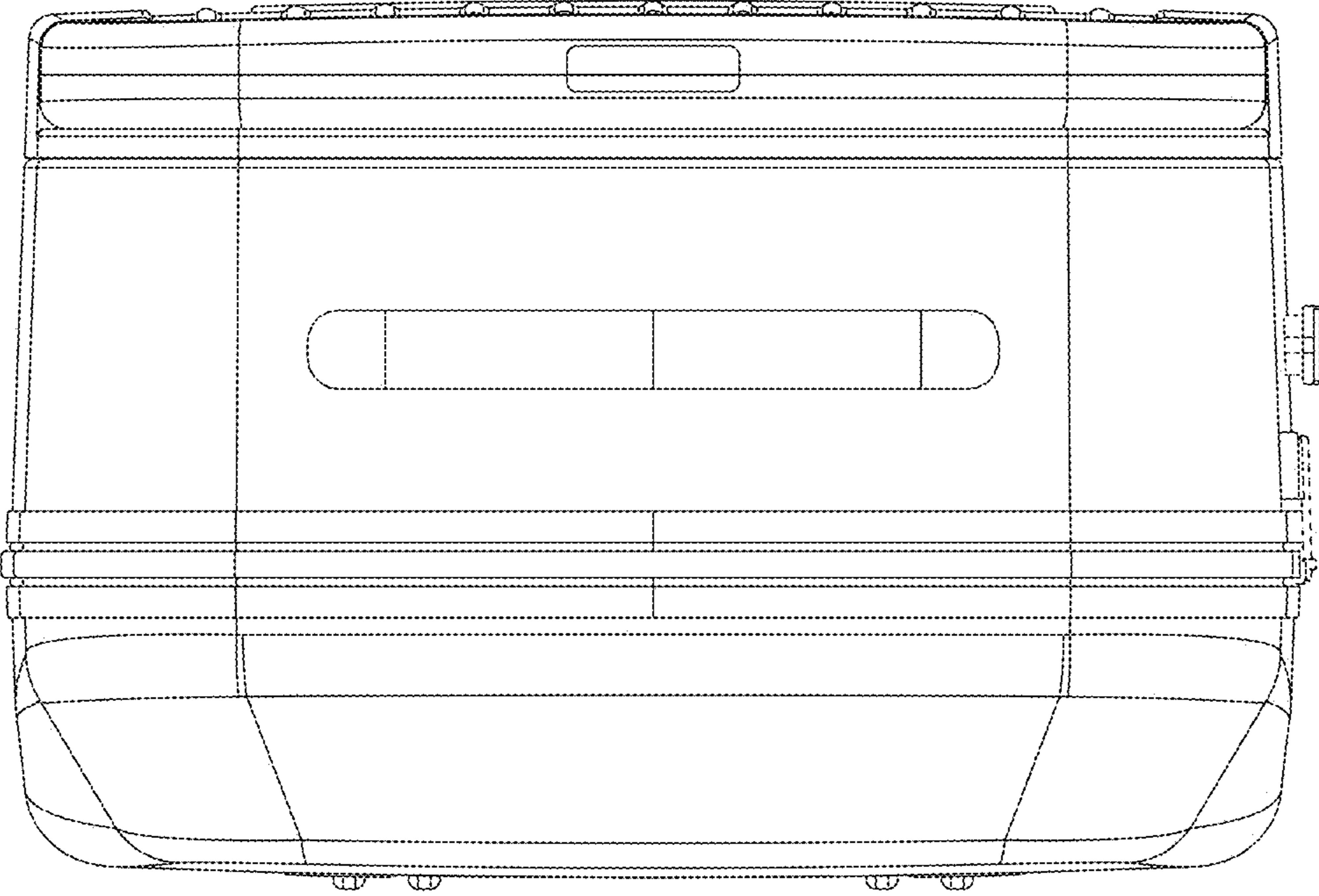

FIG. 5

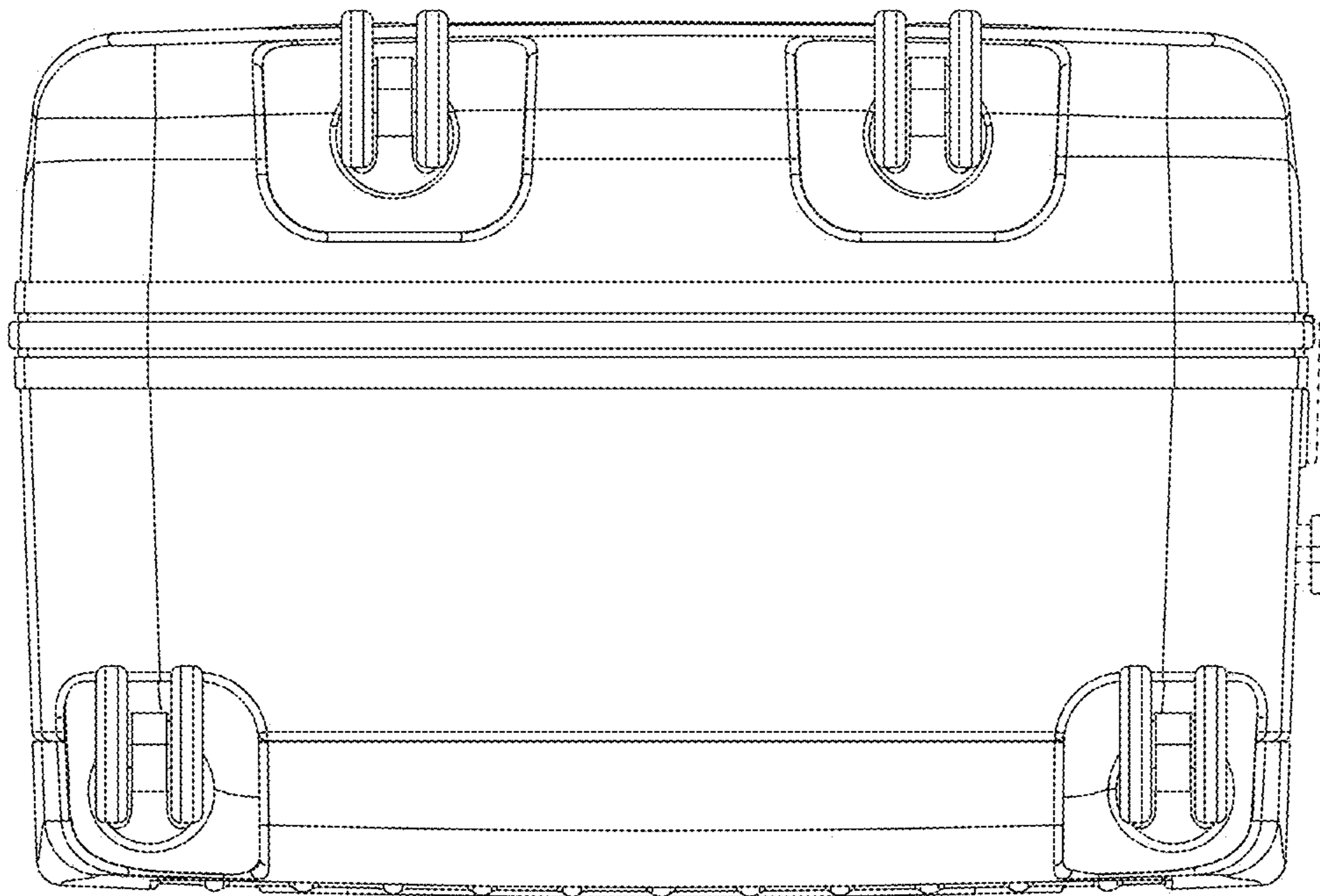

FIG. 6

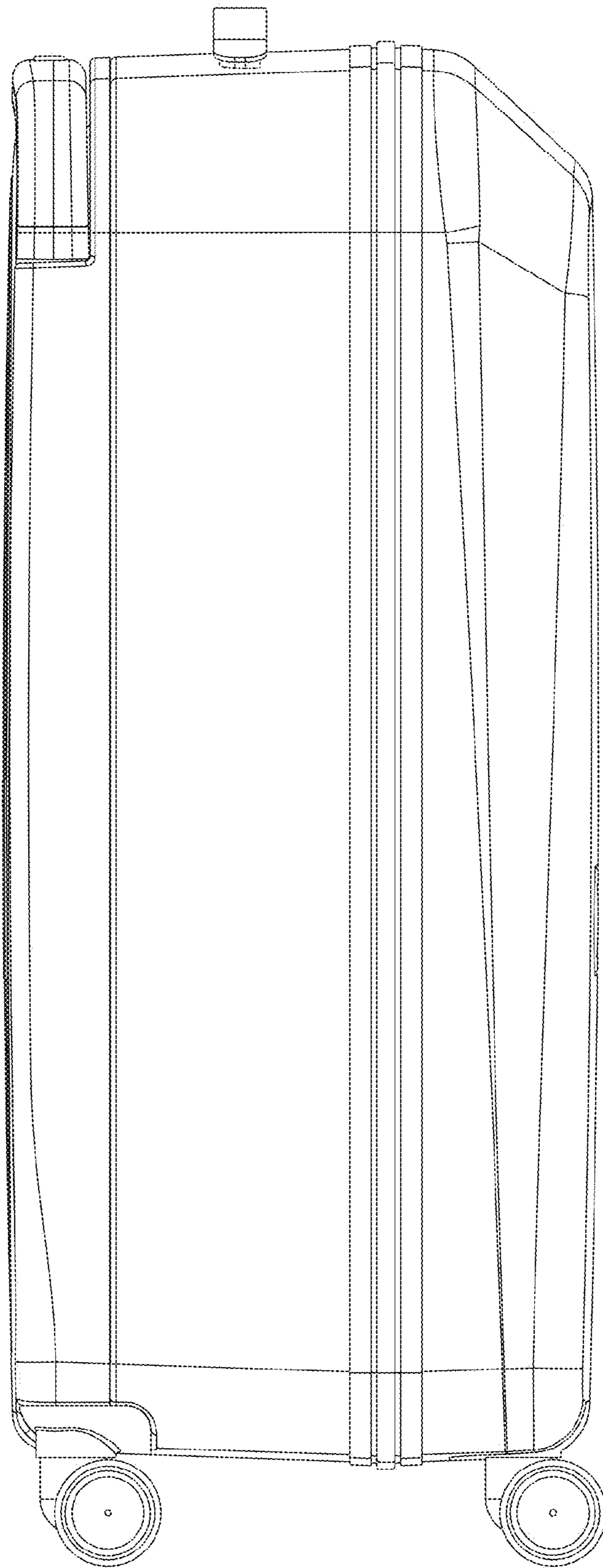

FIG. 7

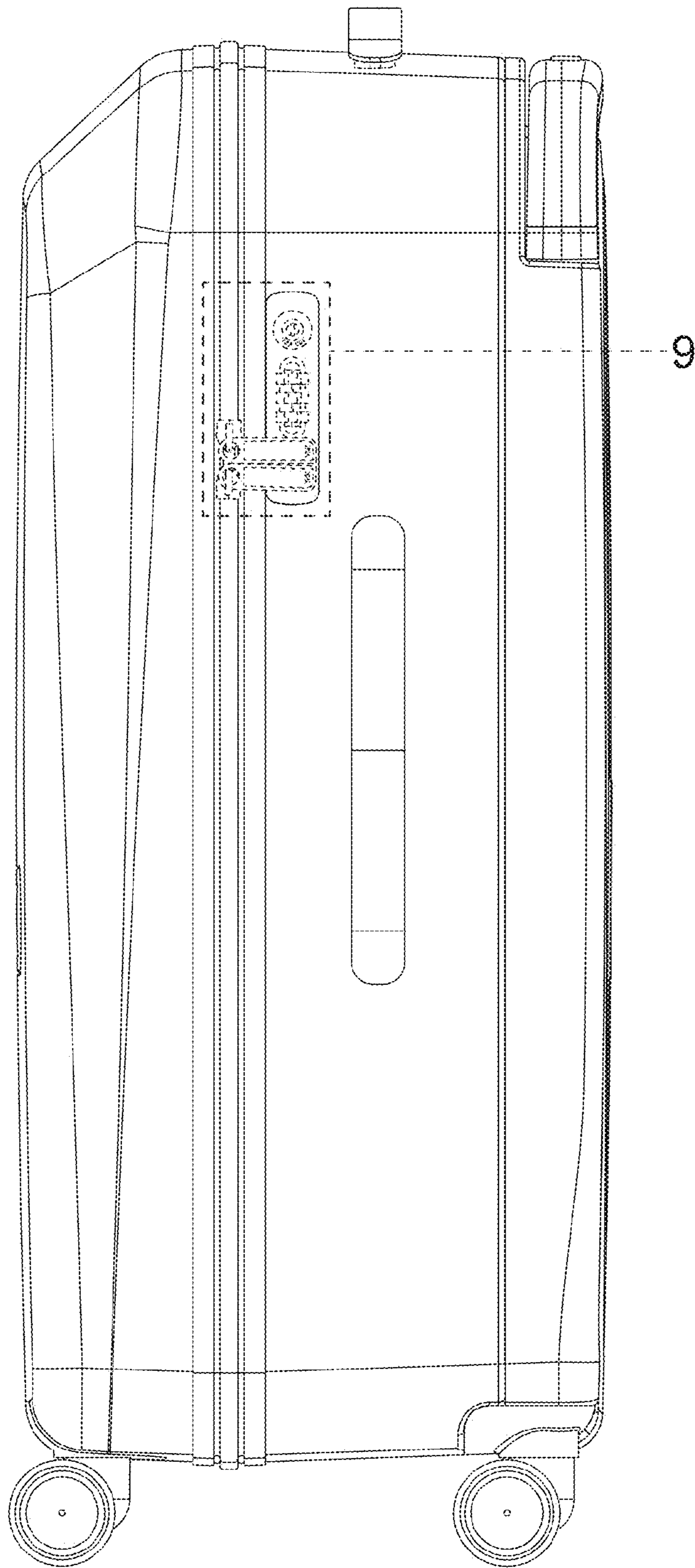

FIG. 8

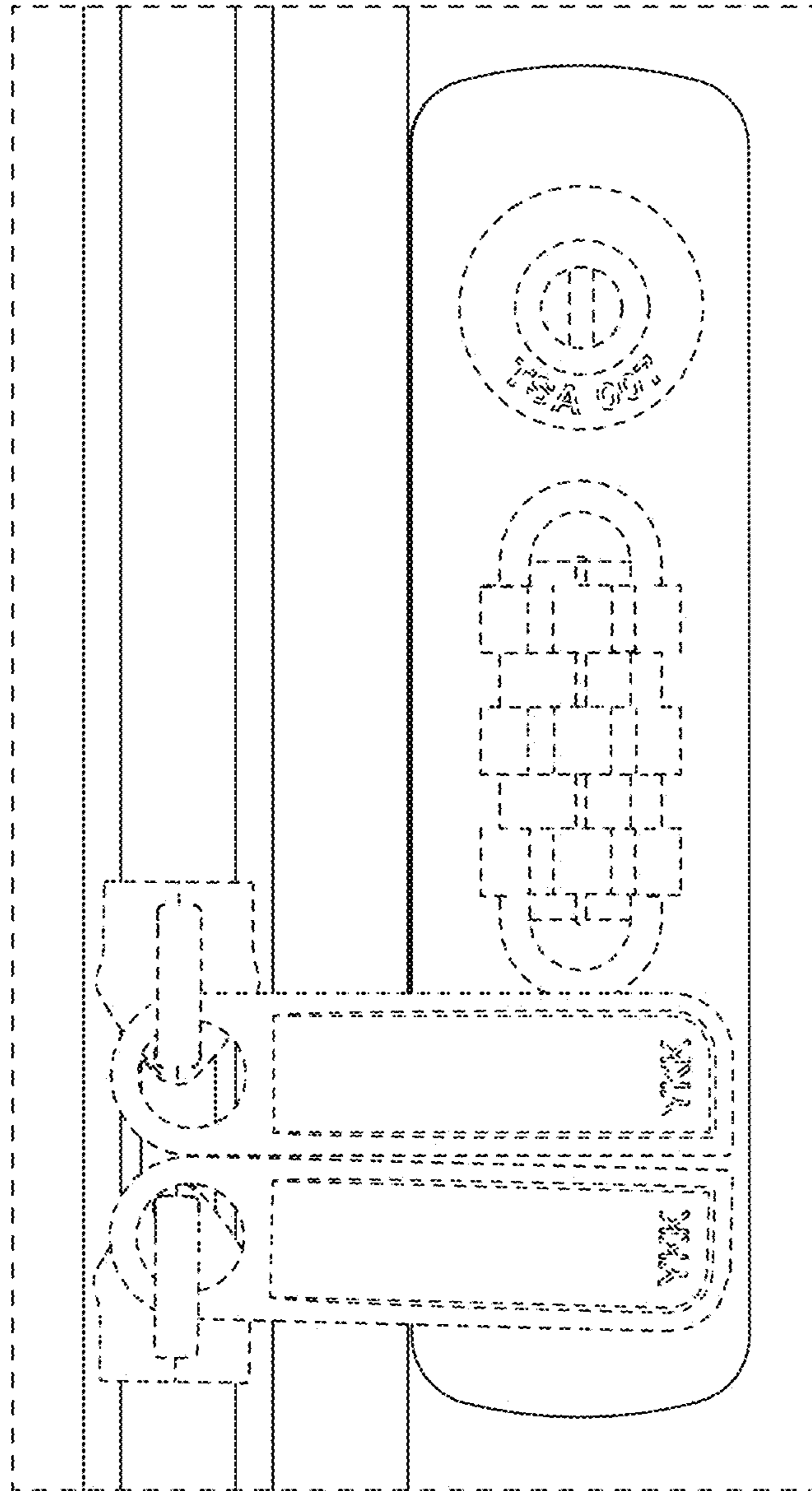

FIG. 9



FIG. 10

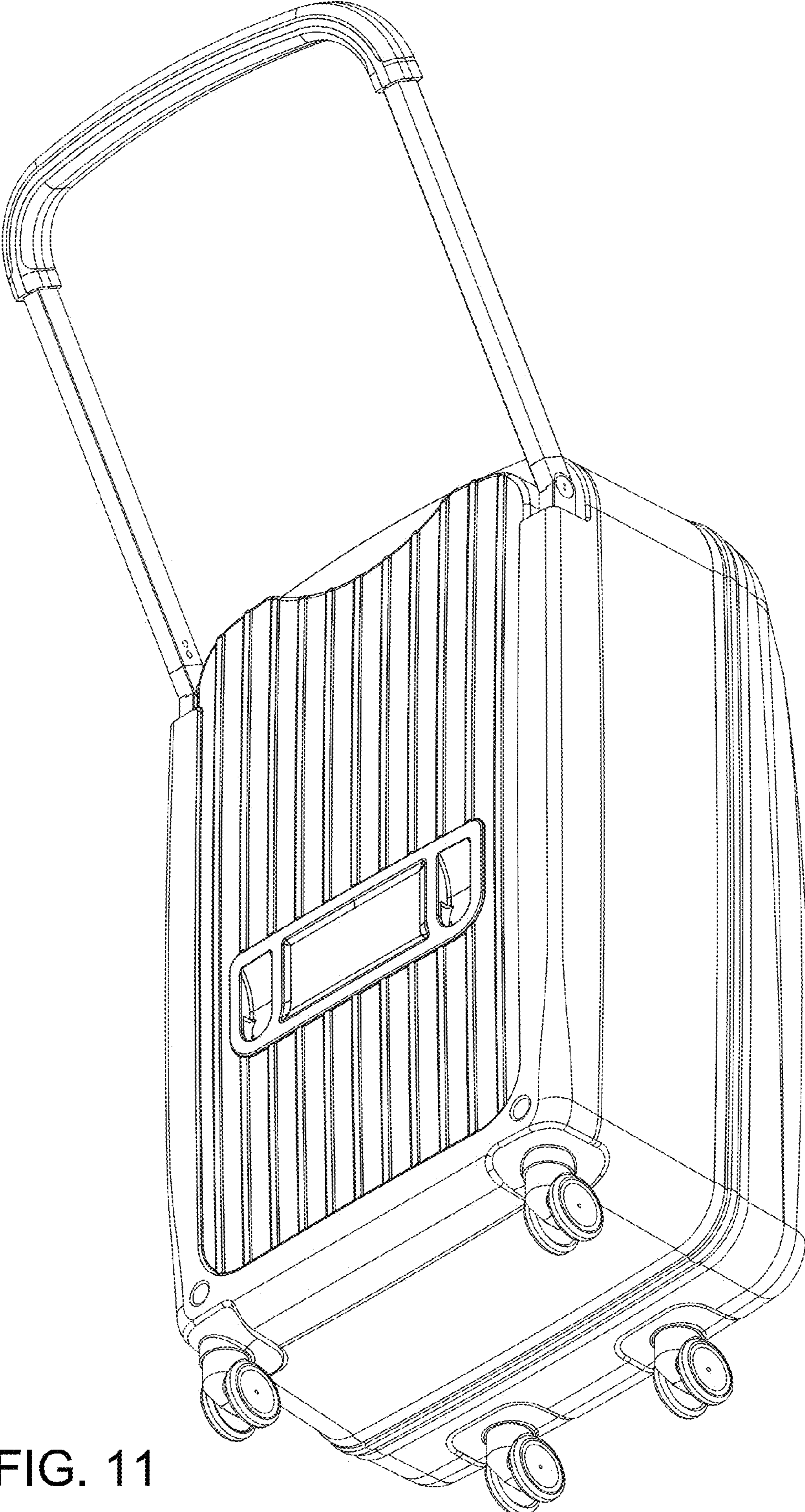

FIG. 11