



US00D920549S

(12) **United States Design Patent**
Park et al.

(10) **Patent No.:** **US D920,549 S**

(45) **Date of Patent:** **** May 25, 2021**

(54) **VEHICLE LOWER HEADLAMP**
(71) Applicant: **GM GLOBAL TECHNOLOGY OPERATIONS LLC**, Detroit, MI (US)
(72) Inventors: **Jonghyuk Park**, Troy, MI (US);
Byeong Hyeok Yun, Irvine, CA (US)
(73) Assignee: **GM GLOBAL TECHNOLOGY OPERATIONS LLC**, Detroit, MI (US)

(**) Term: **15 Years**

(21) Appl. No.: **29/725,078**

(22) Filed: **Feb. 21, 2020**

(51) **LOC (13) Cl.** **26-06**

(52) **U.S. Cl.**
USPC **D26/28**

(58) **Field of Classification Search**
USPC D26/28, 29, 30, 31, 32, 33, 34, 35, 36,
D26/44
CPC F21S 48/00; F21S 48/10; F21S 48/115;
F21S 48/225; F21S 48/1233; F21S
48/1266; F21S 48/1388; F21S 48/2268;
F21V 21/04; F21W 2103/35; F21W 3/40;
F21W 2102/17; F21W 2102/30; F21W
2103/00; F21W 2103/55; F21W 2104/00;
F21W 2107/17; F21W 2107/13
See application file for complete search history.

(56) **References Cited**

U.S. PATENT DOCUMENTS

D570,742 S 6/2008 Takagi et al.
D592,105 S 5/2009 Dean et al.
D597,447 S 8/2009 Folden
D600,595 S 9/2009 Nakamura et al.
D601,925 S 10/2009 O'Donnell
D603,755 S 11/2009 Peters
D604,203 S 11/2009 O'Donnell
D605,082 S 12/2009 Munson

D605,083 S 12/2009 Manoogian, II et al.
D605,977 S 12/2009 Zipfel et al.
D605,978 S 12/2009 Wolff et al.
D608,249 S 1/2010 Peters
D608,690 S 1/2010 Folden et al.
D608,691 S 1/2010 Zak, Jr. et al.
D609,608 S 2/2010 Boniface et al.
D611,387 S 3/2010 Thompson et al.
D611,879 S 3/2010 Kim et al.
D612,297 S 3/2010 Peters et al.
D613,645 S 4/2010 Song et al.
D615,458 S 5/2010 Thompson et al.
D618,595 S 6/2010 Ware et al.
D623,090 S 9/2010 Cox et al.
D627,262 S 11/2010 Ikeda et al.
D635,488 S 4/2011 Phipps
D644,147 S 8/2011 Suh et al.

(Continued)

Primary Examiner — Angela J Lee

(57) **CLAIM**

The ornamental design for a vehicle lower headlamp, as shown and described.

DESCRIPTION

FIG. 1 is a front and left perspective view of a vehicle lower headlamp showing our new design; the mirror image of the vehicle lower headlamp is claimed, but not shown; FIG. 2 is a front elevation of the vehicle lower headlamp of FIG. 1;

FIG. 3 is a left elevation view thereof; FIG. 4 is a right elevation view thereof; FIG. 5 is a rear elevation view thereof; FIG. 6 is a top view thereof; and, FIG. 7 is a bottom view thereof.

The broken lines in the drawings depict portions of the vehicle lower headlamp that form no part of the claimed design. Oblique line shading in the drawings indicates surfaces that can be transparent, translucent, highly polished or reflective surfaces.

1 Claim, 7 Drawing Sheets

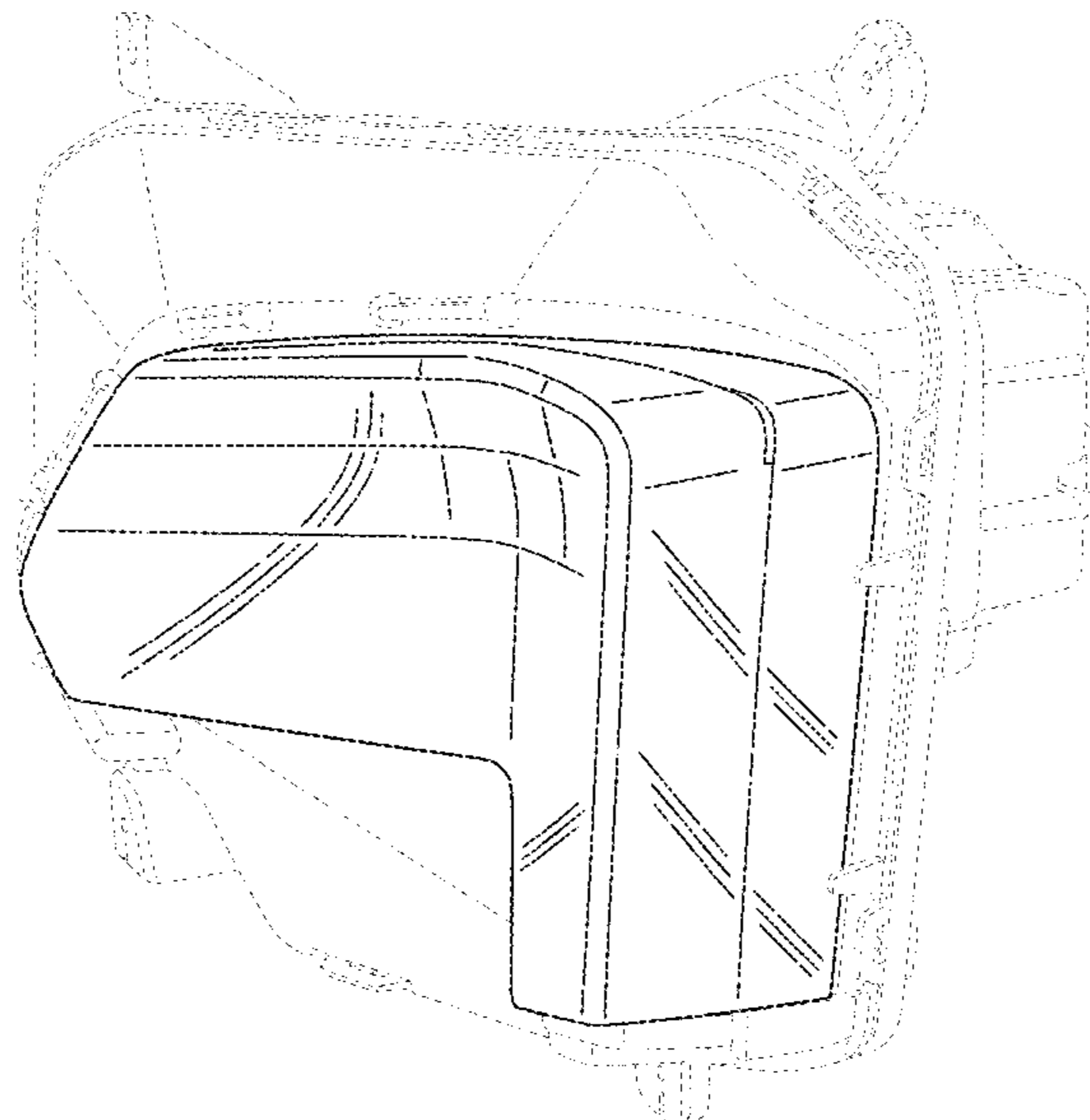

(56)

References Cited

U.S. PATENT DOCUMENTS

D644,567 S	9/2011	Kozub	D749,250 S	2/2016	Thole et al.
D657,718 S	4/2012	Zipfel et al.	D749,985 S	2/2016	Kozub et al.
D659,052 S	5/2012	Ware et al.	D749,997 S	2/2016	McMahan et al.
D659,053 S	5/2012	Ware et al.	D750,001 S	2/2016	Thole et al.
D668,182 S	10/2012	Barba Franco et al.	D753,032 S	4/2016	Smith et al.
D668,183 S	10/2012	Smart	D753,033 S	4/2016	Thole et al.
D678,820 S	3/2013	Son et al.	D753,034 S	4/2016	Thole et al.
D678,821 S	3/2013	Ikeda et al.	D753,035 S	4/2016	Boniface et al.
D680,909 S	4/2013	Munson et al.	D753,559 S	4/2016	McMahan et al.
D680,910 S	4/2013	David	D753,560 S	4/2016	McMahan et al.
D684,899 S	6/2013	Baker	D753,567 S	4/2016	Boniface et al.
D686,536 S	7/2013	McCabe et al.	D754,571 S	4/2016	Boniface et al.
D692,798 S	11/2013	Thurber	D754,572 S	4/2016	McMahan et al.
D692,799 S	11/2013	Smith et al.	D755,088 S	5/2016	McMahan et al.
D696,157 S	12/2013	Loeb	D756,869 S	5/2016	McMahan et al.
D699,629 S	2/2014	Ikeda et al.	D758,271 S	6/2016	McMahan et al.
D700,871 S	3/2014	O'Donnell et al.	D764,975 S	8/2016	Aengenheyster
D703,103 S	4/2014	Lee	D764,976 S	8/2016	Aengenheyster
D704,103 S	5/2014	Mack et al.	D767,449 S	9/2016	Pevovar et al.
D705,132 S	5/2014	Ware et al.	D767,450 S	9/2016	Lee et al.
D705,699 S	5/2014	Ware et al.	D767,451 S	9/2016	Kozub et al.
D712,574 S *	9/2014	Namai D26/28	D767,454 S	9/2016	McMahan et al.
D713,298 S	9/2014	Dyson	D767,458 S	9/2016	Kim
D713,764 S	9/2014	Ferlazzo et al.	D767,459 S	9/2016	Kim
D716,696 S	11/2014	Thole et al.	D767,460 S	9/2016	Kozub et al.
D716,706 S	11/2014	Thole et al.	D767,461 S	9/2016	Kozub et al.
D716,709 S	11/2014	Thole et al.	D771,528 S	11/2016	Smith et al.
D717,696 S	11/2014	Thole et al.	D771,529 S	11/2016	Thole et al.
D718,189 S	11/2014	Krieg et al.	D771,532 S	11/2016	Kapitonov
D718,683 S	12/2014	Thole et al.	D771,533 S	11/2016	Kapitonov
D722,282 S	2/2015	Loeb	D772,766 S	11/2016	Kozub et al.
D722,533 S	2/2015	Thole et al.	D772,767 S	11/2016	Kim
D722,534 S	2/2015	Munson et al.	D773,084 S	11/2016	Kapitonov
D724,510 S	3/2015	McMahan et al.	D773,086 S	11/2016	McCabe et al.
D725,001 S	3/2015	McMahan et al.	D774,226 S	12/2016	McCabe et al.
D726,591 S	4/2015	Jacob	D775,003 S	12/2016	Pevovar et al.
D730,776 S	6/2015	Smart	D775,007 S	12/2016	Thole et al.
D730,783 S	6/2015	Henriques et al.	D775,010 S	12/2016	Kim et al.
D732,427 S	6/2015	Loeb	D775,049 S	12/2016	Scheer et al.
D732,429 S	6/2015	Loeb	D775,549 S	1/2017	Karras
D732,430 S	6/2015	Loeb	D775,554 S	1/2017	Kapitonov
D732,431 S	6/2015	Loeb	D776,020 S	1/2017	Kapitonov
D732,432 S	6/2015	Aengenheyster	D776,581 S	1/2017	Pevovar et al.
D732,433 S	6/2015	Aengenheyster	D776,583 S	1/2017	Scheer et al.
D732,435 S	6/2015	Mackay	D776,841 S	1/2017	Kozub et al.
D733,002 S	6/2015	Loeb	D776,843 S	1/2017	McCabe et al.
D735,611 S	8/2015	Aengenheyster	D776,846 S	1/2017	Willett et al.
D735,627 S	8/2015	Smith	D777,359 S	1/2017	Kozub et al.
D736,451 S	8/2015	Smith	D777,360 S	1/2017	Kozub et al.
D739,306 S	9/2015	McMahan et al.	D777,361 S	1/2017	Kozub et al.
D739,317 S	9/2015	McMahan et al.	D777,604 S	1/2017	McNerney
D741,223 S	10/2015	Kim et al.	D777,605 S	1/2017	Ferlazzo et al.
D743,309 S	11/2015	Thole et al.	D777,620 S	1/2017	Pevovar et al.
D743,313 S	11/2015	Smith et al.	D777,621 S	1/2017	Kim
D743,314 S	11/2015	Thole et al.	D777,622 S	1/2017	Kozub et al.
D743,857 S	11/2015	McMahan et al.	D777,628 S	1/2017	Kozub et al.
D744,158 S	11/2015	Willett et al.	D777,955 S *	1/2017	Willett D26/28
D745,086 S	12/2015	Finos et al.	D778,212 S	2/2017	Kozub et al.
D745,719 S	12/2015	Boniface et al.	D778,215 S	2/2017	Kozub et al.
D745,725 S	12/2015	McMahan et al.	D778,471 S *	2/2017	Ito D26/28
D745,726 S	12/2015	McMahan et al.	D780,064 S	2/2017	Smith et al.
D745,837 S	12/2015	Smith et al.	D780,067 S	2/2017	Zipfel et al.
D746,726 S	1/2016	Smith et al.	D780,068 S	2/2017	Whitla et al.
D746,727 S	1/2016	Smith et al.	D780,077 S	2/2017	Kim et al.
D746,728 S	1/2016	Smith et al.	D780,081 S	2/2017	Lee
D746,729 S	1/2016	Boniface et al.	D780,084 S	2/2017	Scheer et al.
D746,730 S	1/2016	Kim et al.	D780,631 S	3/2017	Kozub et al.
D747,514 S	1/2016	McMahan et al.	D780,644 S	3/2017	Kim et al.
D747,515 S	1/2016	McMahan et al.	D781,184 S	3/2017	Thole et al.
D747,819 S	1/2016	Thole et al.	D781,192 S	3/2017	Kozub et al.
D749,021 S	2/2016	Boniface et al.	D782,379 S	3/2017	Wassell
D749,026 S	2/2016	Smith et al.	D783,482 S	4/2017	Smith et al.
D749,027 S	2/2016	McMahan et al.	D784,213 S	4/2017	Karras
D749,246 S	2/2016	Thole et al.	D784,223 S	4/2017	Lee
D749,249 S	2/2016	Thole et al.	D784,226 S	4/2017	Cheng
			D784,579 S *	4/2017	Cheng D26/28
			D784,877 S	4/2017	Lee
			D784,886 S	4/2017	Smith et al.
			D785,521 S	5/2017	Smith et al.

(56)

References Cited

U.S. PATENT DOCUMENTS

D786,149 S	5/2017	Pevovar et al.	D801,882 S	11/2017	Kozub et al.
D786,743 S	5/2017	Smith et al.	D802,205 S	11/2017	Ruiz
D786,750 S	5/2017	Lee	D802,478 S	11/2017	Perkins
D787,446 S	5/2017	Cockerill	D802,491 S	11/2017	Mainville
D787,984 S	5/2017	Fang	D802,496 S	11/2017	Mainville
D787,988 S	5/2017	Lee	D802,502 S	11/2017	McMahan
D787,989 S	5/2017	Kozub et al.	D803,727 S	11/2017	Noone et al.
D787,990 S	5/2017	Kozub et al.	D803,731 S	11/2017	Zipfel
D787,992 S	5/2017	Lee	D804,370 S	12/2017	Kozub et al.
D787,993 S	5/2017	McCabe et al.	D804,371 S	12/2017	Whitla et al.
D788,001 S	5/2017	Lee	D804,372 S	12/2017	Kozub
D788,641 S	6/2017	Arnold	D804,378 S	12/2017	Perkins
D788,644 S	6/2017	Mueller	D804,379 S	12/2017	McMahan
D788,645 S	6/2017	Mueller	D805,006 S	12/2017	Nakamura
D789,250 S	6/2017	Arnold	D805,013 S	12/2017	Whitla
D789,260 S	6/2017	Smith	D805,014 S	12/2017	Zipfel
D789,575 S	6/2017	Willett	D805,441 S	12/2017	Karras
D789,841 S	6/2017	Lee	D805,964 S	12/2017	Whitla
D789,849 S	6/2017	Lee	D805,965 S	12/2017	Davis
D791,018 S	7/2017	Mylenek	D805,966 S	12/2017	Perkins
D791,644 S	7/2017	Fang	D805,985 S	12/2017	Nakamura
D792,290 S	7/2017	Smith et al.	D806,284 S	* 12/2017	Yamaguchi D26/28
D792,293 S	7/2017	McCabe et al.	D807,232 S	1/2018	Bailie
D792,294 S	7/2017	McCabe et al.	D807,239 S	1/2018	Perkins
D792,295 S	7/2017	McCabe et al.	D807,240 S	1/2018	Perkins
D792,815 S	7/2017	Kozub	D807,241 S	1/2018	Perkins
D792,816 S	7/2017	Kozub	D809,442 S	2/2018	Zipfel et al.
D793,290 S	8/2017	Kozub	D811,269 S	2/2018	Thompson et al.
D793,292 S	8/2017	Lee	D811,942 S	3/2018	Jacob
D793,293 S	8/2017	Lee et al.	D811,957 S	3/2018	Whitla et al.
D793,294 S	8/2017	Lee	D811,958 S	3/2018	Zipfel et al.
D793,295 S	8/2017	McCabe et al.	D811,959 S	3/2018	Perkins
D793,296 S	8/2017	Smith et al.	D811,960 S	3/2018	Nakamura
D793,297 S	8/2017	Smith et al.	D811,961 S	3/2018	Sullivan
D793,299 S	8/2017	Krieg et al.	D811,962 S	3/2018	Sullivan
D793,300 S	8/2017	Krieg et al.	D811,963 S	3/2018	Sullivan
D793,301 S	8/2017	Kozub	D811,964 S	3/2018	Perkins
D793,302 S	8/2017	Kozub	D811,965 S	3/2018	Moffett et al.
D793,311 S	8/2017	Whitla et al.	D812,525 S	3/2018	Lee
D793,590 S	8/2017	Kozub et al.	D812,526 S	3/2018	Zipfel et al.
D793,591 S	8/2017	Kozub et al.	D812,527 S	3/2018	Perkins
D793,917 S	8/2017	Kozub	D812,528 S	3/2018	Nakamura
D793,918 S	8/2017	Kozub	D813,098 S	3/2018	Thompson et al.
D794,229 S	8/2017	Barry	D813,109 S	3/2018	Zipfel et al.
D794,230 S	8/2017	Kozub	D813,110 S	3/2018	Whitla et al.
D795,747 S	8/2017	Bailie	D813,111 S	3/2018	Sullivan
D795,757 S	8/2017	Pevovar et al.	D813,116 S	3/2018	Park
D795,758 S	8/2017	Karras	D813,117 S	3/2018	Sullivan
D795,759 S	8/2017	Kozub et al.	D813,121 S	3/2018	Swaneger
D795,760 S	8/2017	Kozub et al.	D813,730 S	3/2018	Zipfel et al.
D795,762 S	8/2017	Lee	D813,731 S	3/2018	McMahan
D795,763 S	8/2017	Kozub	D813,732 S	3/2018	Whitla et al.
D796,088 S	8/2017	McCabe et al.	D813,733 S	3/2018	Lee
D796,093 S	8/2017	Mainville	D813,734 S	3/2018	Nakamura
D796,390 S	9/2017	Pevovar et al.	D813,740 S	3/2018	Park
D796,711 S	* 9/2017	Matsumoto D26/28	D813,741 S	3/2018	Perkins
D797,537 S	9/2017	Cooper et al.	D813,742 S	3/2018	McMahan et al.
D797,603 S	9/2017	Noone et al.	D813,743 S	3/2018	Lee
D797,614 S	9/2017	Lee	D813,744 S	3/2018	Whitla et al.
D797,616 S	9/2017	Lee	D813,748 S	3/2018	Kim
D797,624 S	9/2017	Nakamura	D813,753 S	3/2018	Loeb
D797,625 S	9/2017	Perkins	D813,754 S	3/2018	Loeb
D797,631 S	9/2017	Pevovar et al.	D813,755 S	3/2018	Loeb
D797,632 S	9/2017	Zipfel et al.	D813,756 S	3/2018	Loeb
D797,967 S	9/2017	Barry	D813,757 S	3/2018	Kozub
D797,970 S	9/2017	Mainville	D813,758 S	3/2018	Gonzales
D797,971 S	9/2017	Mainville	D813,759 S	3/2018	Perkins
D797,972 S	9/2017	Whitla et al.	D814,369 S	4/2018	Loeb
D798,204 S	9/2017	Mainville	D814,982 S	4/2018	Whitla et al.
D799,384 S	10/2017	Kozub et al.	D814,983 S	4/2018	Whitla et al.
D799,385 S	10/2017	Kozub et al.	D815,570 S	4/2018	McMahan et al.
D799,386 S	10/2017	Kozub et al.	D815,572 S	4/2018	Perkins
D799,728 S	10/2017	Whitla et al.	D815,573 S	4/2018	Whitla et al.
D801,236 S	10/2017	Kozub et al.	D815,574 S	4/2018	Mainville
D801,577 S	10/2017	Ruiz	D815,985 S	4/2018	Mueller
			D815,993 S	4/2018	Kozub et al.
			D815,994 S	4/2018	Nakamura
			D816,003 S	4/2018	Perkins
			D816,558 S	5/2018	McMahan et al.

(56)

References Cited

U.S. PATENT DOCUMENTS

D816,559 S	5/2018	McMahan et al.	D840,285 S	2/2019	Mack et al.
D816,561 S	5/2018	McMahan	D840,286 S	2/2019	Mack et al.
D816,562 S	5/2018	Whitla et al.	D840,293 S	2/2019	Koo et al.
D816,563 S	5/2018	McMahan et al.	D840,302 S	2/2019	O'Donnell et al.
D816,564 S	5/2018	Kim	D840,303 S	2/2019	Park Cheng
D816,565 S	5/2018	Kim	D840,306 S	2/2019	Kozub
D816,566 S	5/2018	Loeb	D840,565 S	2/2019	Whitla et al.
D817,836 S	5/2018	McMahan et al.	D840,570 S	2/2019	Kim et al.
D818,156 S	5/2018	Kim et al.	D840,571 S	2/2019	Zipfel et al.
D818,157 S	5/2018	Zipfel et al.	D840,572 S	2/2019	Perkins
D818,158 S	5/2018	Zipfel et al.	D840,885 S	2/2019	Park Cheng
D818,159 S	5/2018	Zipfel et al.	D841,527 S	2/2019	Kozub et al.
D818,160 S	5/2018	Perkins	D841,532 S	2/2019	Koo et al.
D818,406 S	5/2018	McMahan et al.	D841,540 S	2/2019	Koo et al.
D818,876 S	5/2018	Whitla et al.	D841,541 S	2/2019	Krieg
D818,877 S	5/2018	Nakamura et al.	D841,542 S	2/2019	Koo et al.
D818,878 S	5/2018	McMahan et al.	D841,547 S	2/2019	Zipfel et al.
D818,892 S	5/2018	Lee	D841,843 S	2/2019	Park
D818,893 S	5/2018	Kim	D841,844 S	2/2019	Perkins
D818,903 S	5/2018	Zipfel et al.	D841,845 S	2/2019	Park
D818,906 S	5/2018	McMahan	D842,178 S	3/2019	Pinazzo et al.
D818,907 S	5/2018	Whitla et al.	D842,306 S	3/2019	Lindo et al.
D818,915 S	5/2018	Kozub et al.	D843,023 S	3/2019	Whitla et al.
D818,922 S	5/2018	Whitla et al.	D843,024 S	3/2019	Hochmuth
D819,505 S	6/2018	McMahan et al.	D843,025 S	3/2019	Smith et al.
D819,519 S	6/2018	Whitla et al.	D843,275 S	3/2019	Koo et al.
D821,617 S	6/2018	Perkins	D843,280 S	3/2019	Thurber et al.
D822,550 S	7/2018	Wassell et al.	D843,614 S	3/2019	Whitla et al.
D822,551 S	7/2018	McMahan et al.	D843,616 S	3/2019	Smith et al.
D823,188 S	7/2018	Loeb	D843,617 S	3/2019	Smith et al.
D823,738 S	7/2018	Kim	D843,891 S	3/2019	Thompson et al.
D823,741 S	7/2018	Kim	D843,904 S	3/2019	Kim
D823,762 S	7/2018	Loeb	D844,184 S	3/2019	Whitla et al.
D823,763 S	7/2018	Koo et al.	D844,185 S	3/2019	Hochmuth
D824,811 S	8/2018	Mainville	D844,186 S	3/2019	Smith et al.
D824,812 S	8/2018	Loeb	D845,184 S	4/2019	Zipfel
D824,824 S	8/2018	Kim	D845,186 S	4/2019	Koo et al.
D824,825 S	8/2018	Loeb	D845,187 S	4/2019	Pinazzo et al.
D825,083 S	8/2018	Perkins	D845,188 S	4/2019	Pinazzo et al.
D825,388 S	8/2018	Karras et al.	D845,189 S	4/2019	Pinazzo et al.
D825,403 S	8/2018	Whitla et al.	D845,190 S	4/2019	Zipfel
D826,114 S	8/2018	Smith et al.	D845,196 S	4/2019	Kozub
D826,435 S	8/2018	Kim	D845,518 S	4/2019	Kozub
D826,803 S	8/2018	Smith et al.	D845,519 S	4/2019	Zipfel
D827,506 S	9/2018	McMahan et al.	D846,448 S	4/2019	Loeb
D827,508 S	9/2018	Whitla et al.	D846,457 S	4/2019	Koo et al.
D827,510 S	9/2018	Kim	D846,458 S	4/2019	Mack et al.
D827,527 S	9/2018	Loeb	D846,769 S	4/2019	Koo et al.
D828,246 S	9/2018	Loeb	D846,770 S	4/2019	Kozub
D828,261 S	9/2018	Moffett et al.	D846,771 S	4/2019	Zipfel
D828,935 S	9/2018	Hochmuth	D846,772 S	4/2019	Pinazzo et al.
D829,622 S	10/2018	Jacob	D847,027 S	4/2019	Loeb
D830,241 S	10/2018	Kozub	D847,028 S	4/2019	Loeb
D830,242 S	10/2018	Zipfel	D847,038 S	4/2019	Loeb
D830,252 S	10/2018	Swanseger	D847,041 S	4/2019	Blanski et al.
D830,258 S	10/2018	McMahan et al.	D847,042 S	4/2019	Pinazzo et al.
D830,261 S	10/2018	Jacob	D847,043 S	4/2019	Kozub
D830,589 S	10/2018	Henriques	D847,044 S	4/2019	Zipfel
D832,752 S	11/2018	Lee	D847,045 S	4/2019	Whitla et al.
D835,003 S	12/2018	Thompson et al.	D847,046 S	4/2019	Whitla et al.
D835,012 S	12/2018	Smith et al.	D847,047 S	4/2019	Krieg et al.
D836,223 S	* 12/2018	Kim D26/28	D847,390 S	4/2019	Koo et al.
D837,105 S	1/2019	Loeb	D847,391 S	4/2019	Pinazzo et al.
D837,109 S	1/2019	Kozub et al.	D847,392 S	4/2019	Zipfel
D837,424 S	1/2019	Whitla et al.	D847,699 S	5/2019	Kozub
D838,015 S	1/2019	McMahan et al.	D847,700 S	5/2019	Kozub
D838,016 S	1/2019	McMahan et al.	D847,701 S	5/2019	Kozub
D838,390 S	1/2019	McMahan et al.	D847,702 S	5/2019	Zipfel
D838,391 S	1/2019	McMahan et al.	D847,703 S	5/2019	Kozub
D839,157 S	1/2019	Smith et al.	D847,704 S	5/2019	Zipfel
D839,163 S	1/2019	Pinazzo et al.	D847,705 S	5/2019	Zipfel
D839,164 S	1/2019	Zipfel	D847,707 S	5/2019	Park Cheng et al.
D839,460 S	1/2019	Zipfel et al.	D847,714 S	5/2019	Mack et al.
D840,068 S	2/2019	Zipfel et al.	D848,315 S	5/2019	Koo et al.
D840,069 S	2/2019	Perkins	D848,318 S	5/2019	McMahan et al.
			D848,320 S	5/2019	Pinazzo et al.
			D848,322 S	5/2019	Mack et al.
			D848,323 S	5/2019	Mack et al.
			D848,324 S	5/2019	Thurber et al.

(56)

References Cited

U.S. PATENT DOCUMENTS

D848,325 S	5/2019	Thurber et al.	D856,875 S	8/2019	Kozub
D848,647 S	5/2019	Kozub	D856,876 S	8/2019	Kapitonov
D848,908 S	5/2019	Krieg	D857,260 S	8/2019	Kil et al.
D848,909 S	5/2019	Lee	D857,567 S	8/2019	Blanski et al.
D848,911 S	5/2019	De Leon	D857,936 S	8/2019	Kil et al.
D848,915 S	5/2019	Izard	D857,938 S	8/2019	Blanski et al.
D849,627 S	5/2019	Zipfel	D857,939 S	8/2019	Kozub
D849,629 S	5/2019	De Leon	D857,940 S	8/2019	Park
D849,630 S	5/2019	De Leon	D857,941 S	8/2019	Whitla et al.
D850,341 S	6/2019	Riggs et al.	D857,942 S	8/2019	Perkins
D850,989 S	6/2019	Kozub	D857,943 S	8/2019	Hochmuth
D851,002 S	6/2019	Kozub	D857,944 S	8/2019	Pinazzo et al.
D851,541 S	6/2019	Pinazzo	D857,945 S	8/2019	Smith et al.
D851,542 S	6/2019	Mack	D857,946 S	8/2019	Smith et al.
D851,547 S	6/2019	Mack et al.	D857,947 S	8/2019	Koo et al.
D851,548 S	6/2019	Mack et al.	D857,948 S	8/2019	Koo et al.
D851,549 S	6/2019	Mack et al.	D857,949 S	8/2019	Smith et al.
D851,550 S	6/2019	Mack et al.	D857,950 S	8/2019	Zipfel
D851,551 S	6/2019	Mack et al.	D857,951 S	8/2019	Whitla et al.
D851,552 S	6/2019	Mack et al.	D857,952 S	8/2019	Smith et al.
D851,555 S	6/2019	Whitla et al.	D858,373 S	9/2019	Blanski et al.
D851,556 S	6/2019	Thurber et al.	D858,377 S	9/2019	Riggs et al.
D851,557 S	6/2019	Thurber et al.	D858,813 S	9/2019	Datta
D851,558 S	6/2019	Thurber et al.	D858,814 S	9/2019	Burns
D851,559 S	6/2019	Thurber et al.	D858,817 S	9/2019	Henriques
D851,560 S	6/2019	Yong et al.	D858,818 S	9/2019	McMahan et al.
D851,561 S	6/2019	Yong et al.	D858,819 S	9/2019	McMahan et al.
D852,093 S	6/2019	Kozub	D858,820 S	9/2019	McMahan et al.
D852,094 S	6/2019	Zipfel	D858,821 S	9/2019	Park
D852,096 S	6/2019	Kozub	D858,822 S	9/2019	Whitla et al.
D852,099 S	6/2019	Loeb	D858,823 S	9/2019	Zipfel
D852,389 S	6/2019	Koo et al.	D858,824 S	9/2019	Pinazzo et al.
D852,393 S	6/2019	Whitla et al.	D859,229 S	9/2019	Karras et al.
D853,903 S	7/2019	Loeb	D859,230 S	9/2019	Parkinson et al.
D853,904 S	7/2019	Koo et al.	D859,231 S	9/2019	Wilkins et al.
D853,924 S	7/2019	Riggs et al.	D859,232 S	9/2019	Izard et al.
D854,462 S	7/2019	Lee	D859,233 S	9/2019	Izard et al.
D854,471 S	7/2019	Lee	D859,237 S	9/2019	Koo et al.
D854,977 S	7/2019	Parkinson et al.	D859,238 S	9/2019	Smith et al.
D854,979 S	7/2019	Krieg et al.	D859,239 S	9/2019	Sullivan et al.
D854,988 S	7/2019	Krieg	D859,246 S	9/2019	Thurber et al.
D854,991 S	7/2019	Whitla et al.	D859,248 S	9/2019	Wilkins et al.
D855,503 S	8/2019	Blanski et al.	D859,252 S	9/2019	Krieg
D855,504 S	8/2019	Lee	D859,253 S	9/2019	Izard
D855,505 S	8/2019	Thurber et al.	D859,254 S	9/2019	Izard
D855,507 S	8/2019	Blanski et al.	D859,707 S	9/2019	McMahan et al.
D855,508 S	8/2019	Wilkins et al.	D859,708 S	9/2019	Kozub
D855,509 S	8/2019	Wilkins	D859,709 S	9/2019	Zipfel
D855,515 S	8/2019	Riggs et al.	D860,075 S	9/2019	Riggs et al.
D855,518 S	8/2019	Whitla et al.	D860,076 S	9/2019	Bartels et al.
D855,520 S	8/2019	Parkinson	D860,077 S	9/2019	Riggs et al.
D855,523 S	8/2019	Perkins	D860,078 S	9/2019	O'Donnell et al.
D855,524 S	8/2019	Lee	D860,079 S	9/2019	Sullivan et al.
D856,201 S	8/2019	Blanski et al.	D860,085 S	9/2019	Koo et al.
D856,204 S	8/2019	Kapitonov	D860,489 S	9/2019	Henriques
D856,206 S	8/2019	De Leon	D860,490 S	9/2019	Henriques
D856,242 S	8/2019	Blanski et al.	D863,625 S *	10/2019	Kim D26/28
D856,864 S	8/2019	Kapitonov	D874,035 S *	1/2020	Park Cheng D26/28
D856,874 S	8/2019	Kozub	D874,693 S *	2/2020	Blanski D26/28
			D888,999 S *	6/2020	Zhang D26/28

* cited by examiner

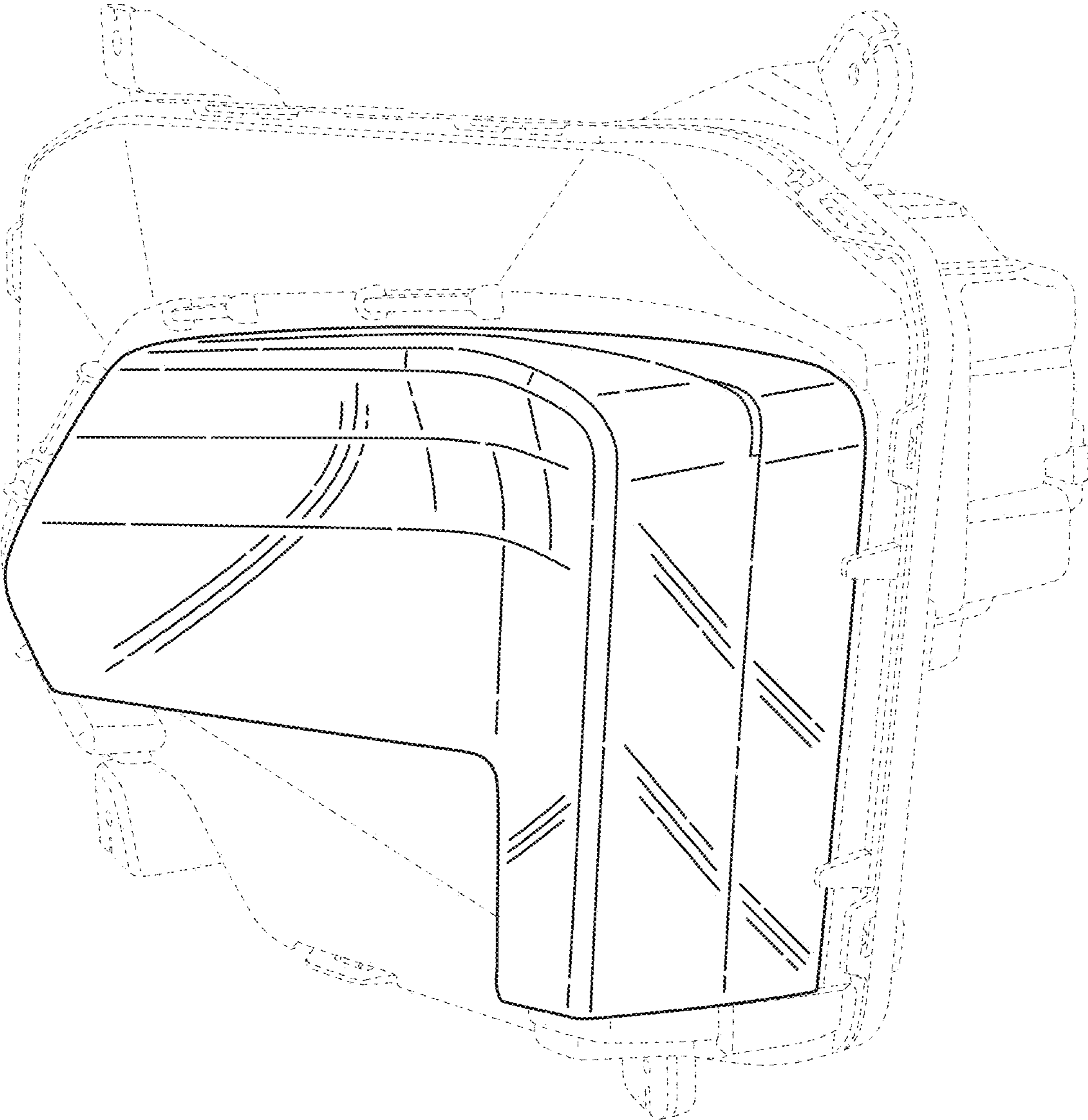

FIG. 1

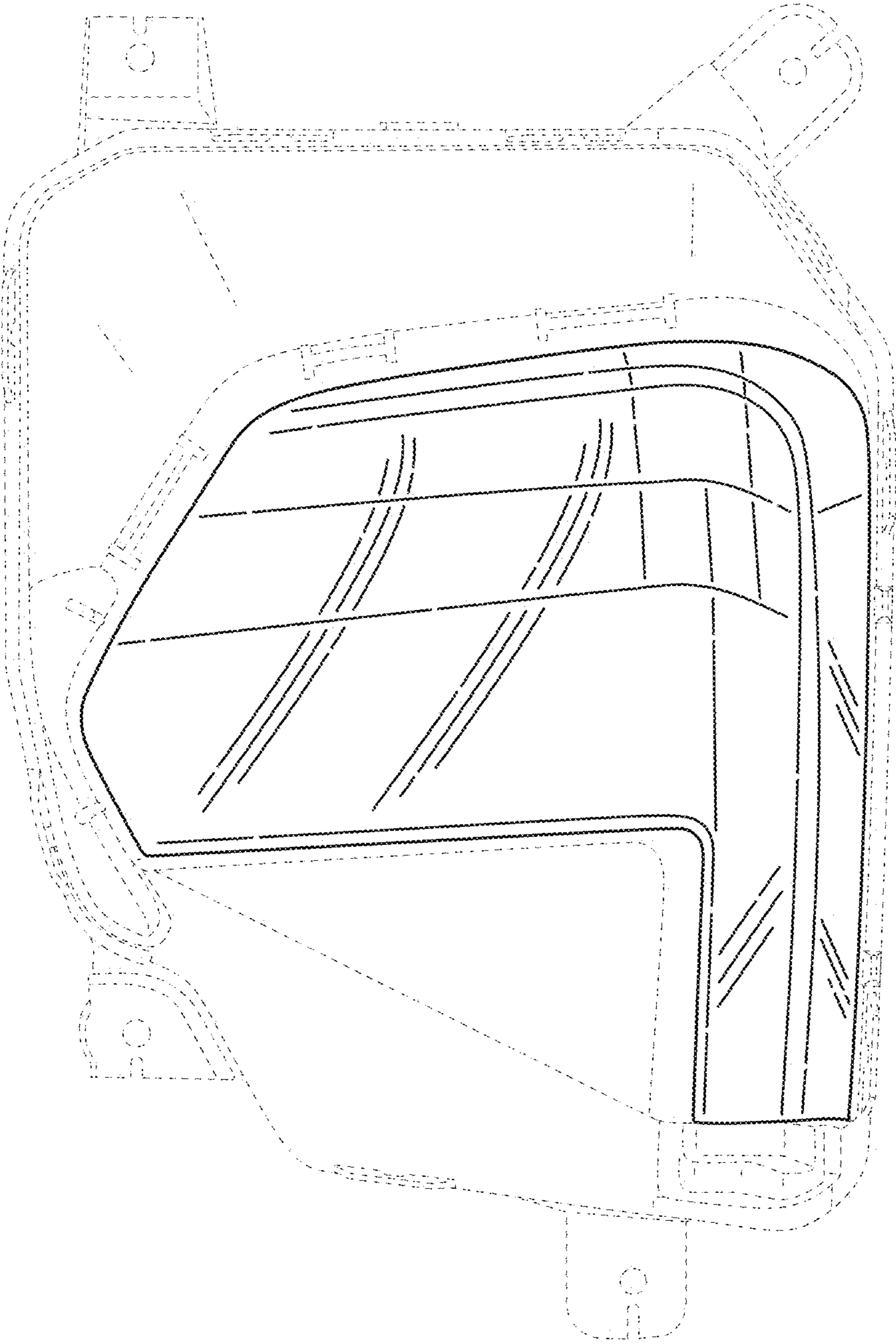

FIG. 2

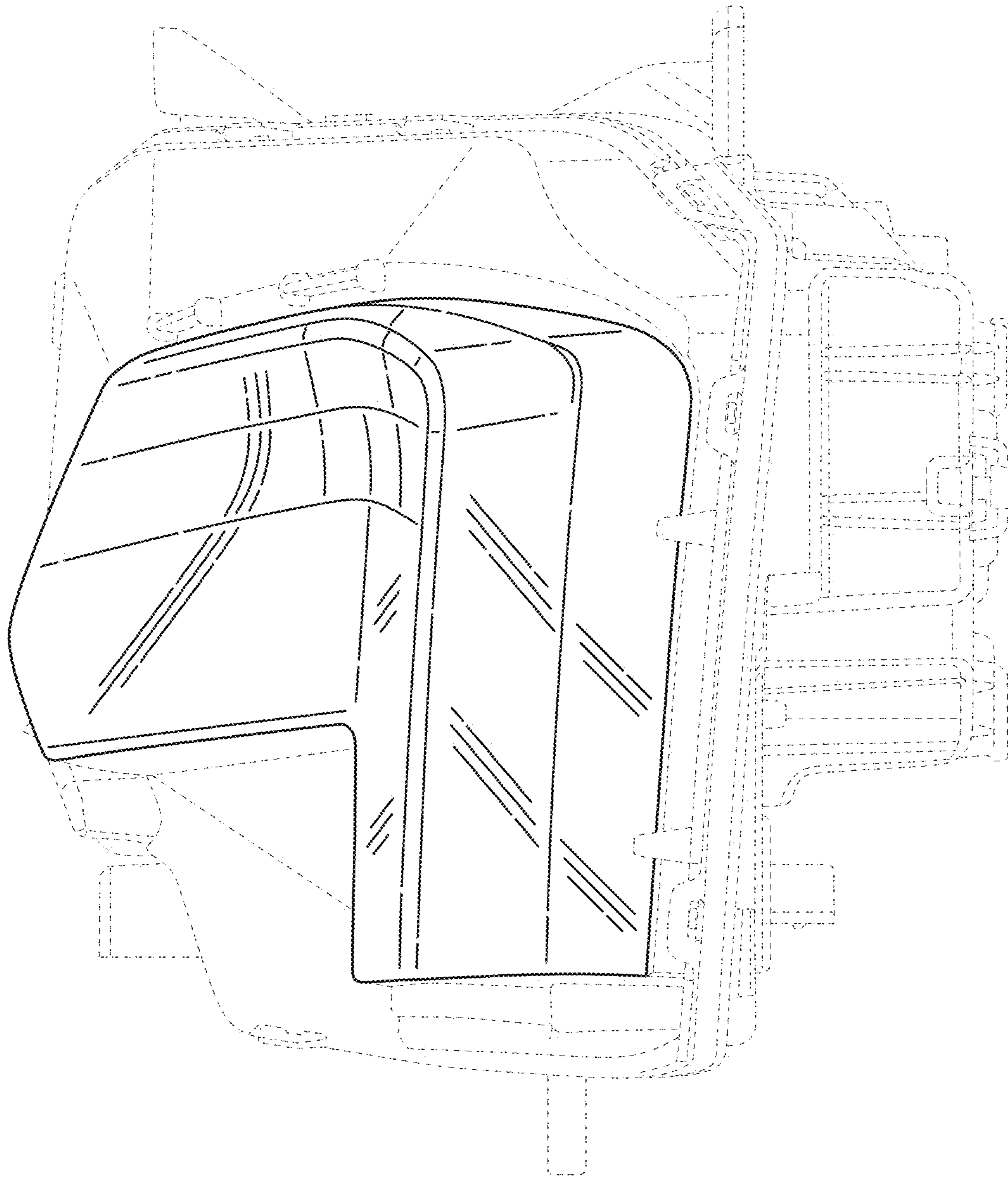

FIG. 3

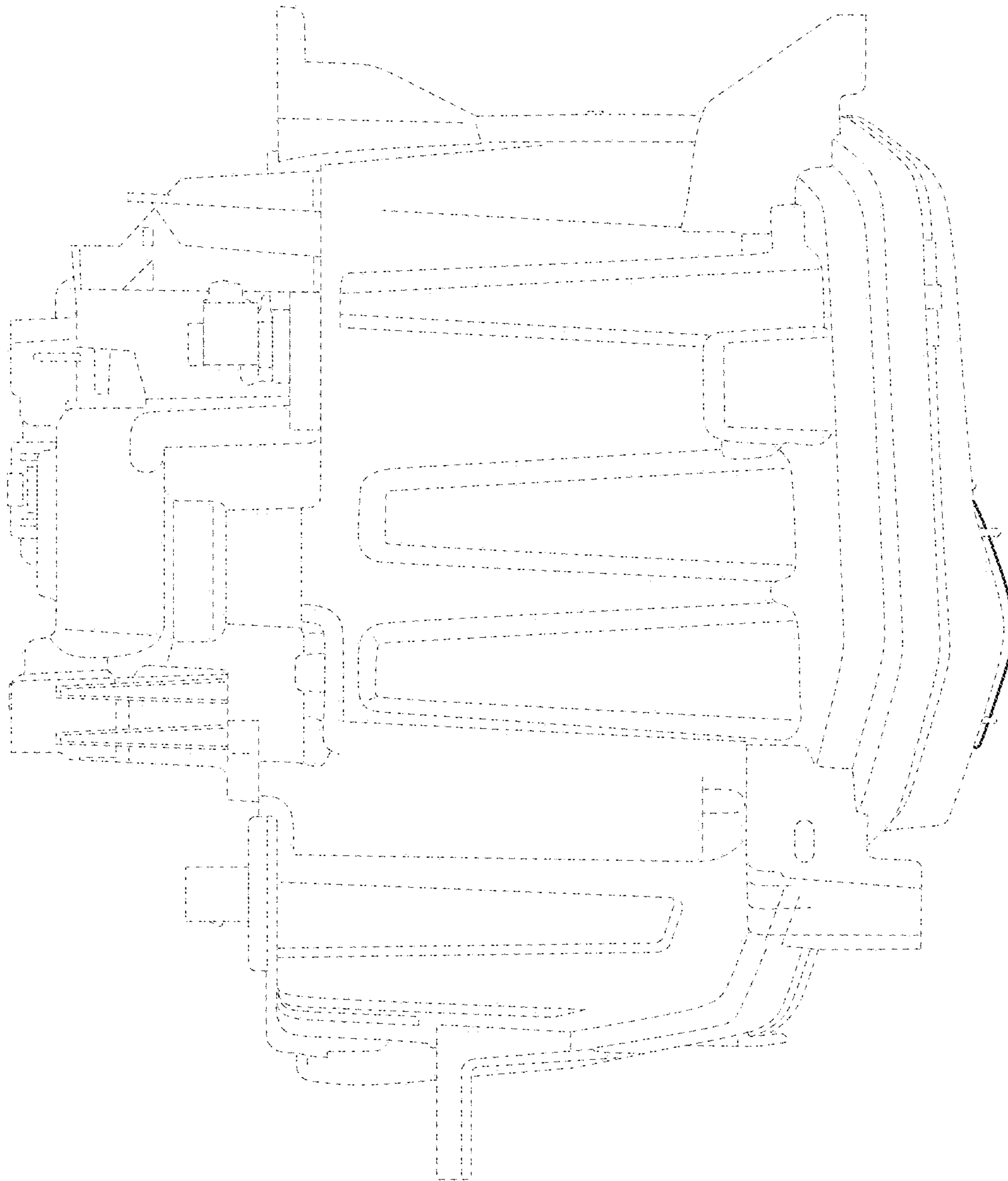

FIG. 4

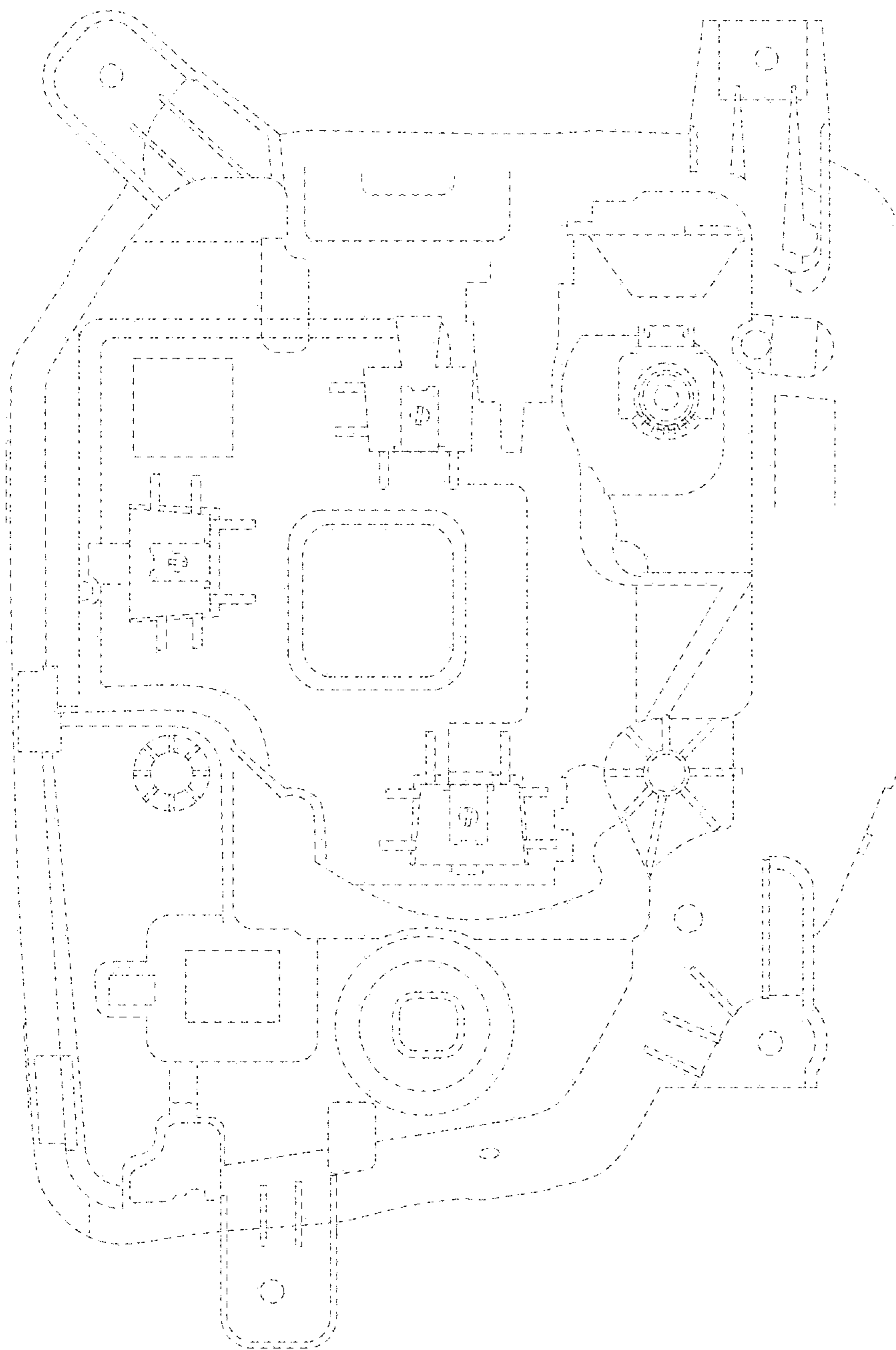

FIG. 5

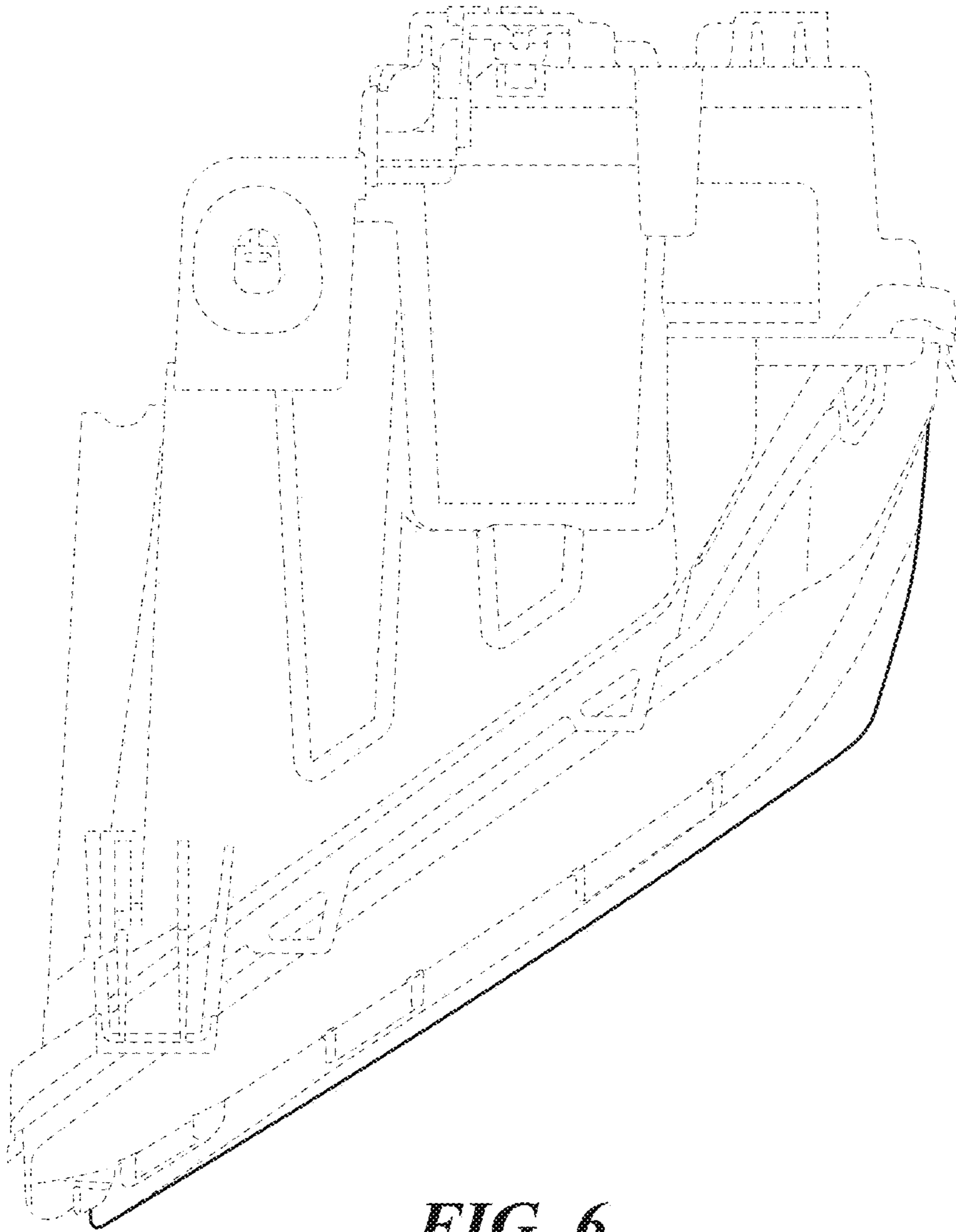

FIG. 6

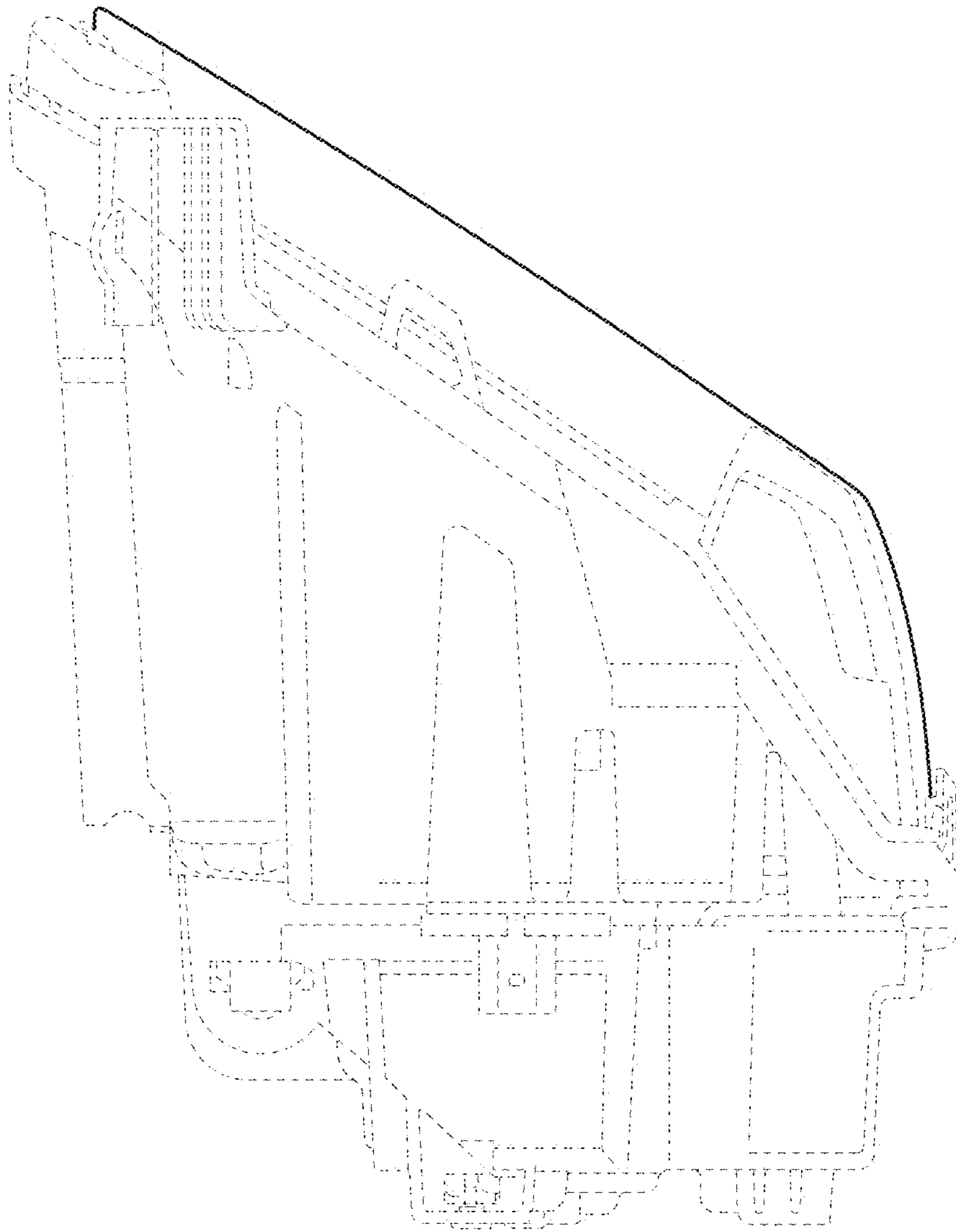

FIG. 7