



US00D920442S

(12) **United States Design Patent** (10) **Patent No.:** **US D920,442 S**  
**Tearne et al.** (45) **Date of Patent:** **\*\* May 25, 2021**

(54) **FLYING DEVICE** 6,976,653 B2 \* 12/2005 Perlo ..... B64C 27/20  
244/12.2  
(71) Applicant: **SPIN MASTER LTD.**, Toronto (CA) D539,358 S \* 3/2007 Shi ..... D21/441  
7,273,195 B1 \* 9/2007 Gollhofer ..... A63H 27/12  
244/17.11  
(72) Inventors: **Daryl R. Tearne**, Toronto (CA);  
**Robert M. O'Brien**, Ajax (CA);  
**Charles Sink**, Friday Harbor, WA (US) (Continued)

**FOREIGN PATENT DOCUMENTS**

(73) Assignee: **Spin Master Ltd.**, Toronto (CA) CN 104260605 A 1/2015  
CN 205131639 U 4/2016  
CN 106741911 A 5/2017

(\*\*) Term: **15 Years**

(21) Appl. No.: **29/680,449**

**OTHER PUBLICATIONS**

(22) Filed: **Feb. 15, 2019**

EP 19168177.4, Partial European Search Report, dated Oct. 1, 2019,  
European Patent Office.

(51) **LOC (13) Cl.** ..... **21-01**

(52) **U.S. Cl.**  
USPC ..... **D21/441**

(Continued)

(58) **Field of Classification Search**  
USPC ..... D12/1, 2, 3, 4, 16.1, 319-345;  
D21/437-455  
CPC ..... B64C 29/0033; B64C 2201/021; B64C  
29/02; B64C 2201/088; B64C 2201/104;  
B64C 2201/141  
See application file for complete search history.

*Primary Examiner* — Marissa J Cash

(74) *Attorney, Agent, or Firm* — Millman IP Inc.

(57) **CLAIM**

The ornamental design for a flying device, as shown and described.

(56) **References Cited**

**DESCRIPTION**

**U.S. PATENT DOCUMENTS**

1,110,738 A \* 9/1914 Berez ..... A63B 67/16  
446/255  
1,445,402 A 2/1923 Le Velle  
1,479,163 A \* 1/1924 Tyrrell ..... B64B 1/58  
446/186  
2,079,942 A 5/1937 Le Velle  
2,783,584 A \* 3/1957 Venturella ..... A63H 27/10  
446/225  
5,525,086 A \* 6/1996 Gentile ..... A63H 27/10  
446/234  
D372,277 S \* 7/1996 Henley ..... D21/436  
D377,058 S \* 12/1996 Henley ..... D21/436  
5,743,489 A 4/1998 Stemme  
6,550,715 B1 \* 4/2003 Reynolds ..... A63H 27/12  
244/17.11  
6,550,719 B2 4/2003 König

FIG. 1 is a perspective view from above, to the front and to one side of the new design for a flying device;  
FIG. 2 is a front view thereof;  
FIG. 3 is a rear view thereof;  
FIG. 4 is a left side view thereof;  
FIG. 5 is a right side view thereof;  
FIG. 6 is a top view thereof; and,  
FIG. 7 is a bottom view thereof.  
In the drawings, the evenly spaced broken lines depict portions of the flying device that form no part of the claimed design, and the dash-dot lines represent boundaries that form no part thereof.

**1 Claim, 7 Drawing Sheets**

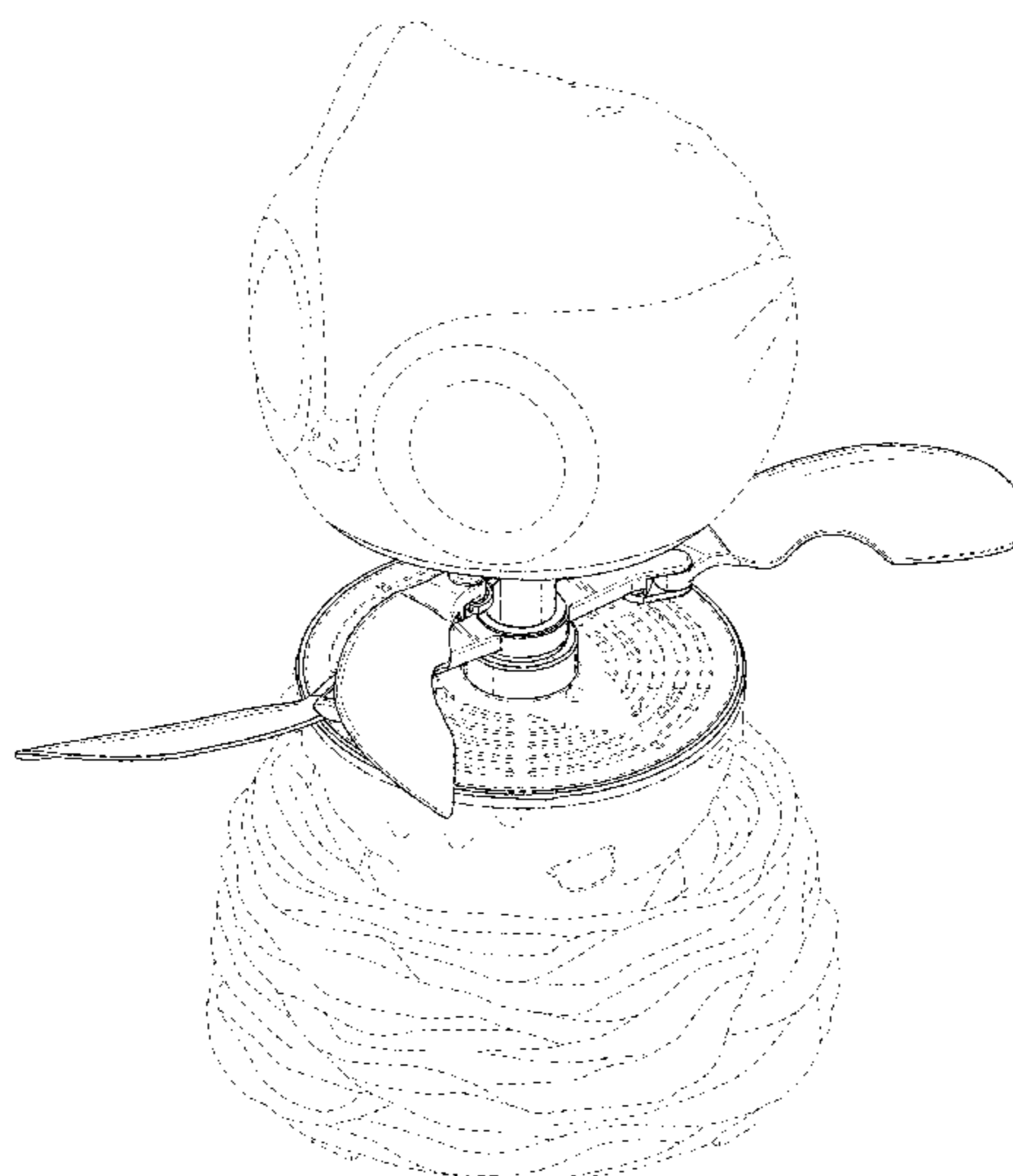

(56)

**References Cited**

## U.S. PATENT DOCUMENTS

7,416,466 B2 \* 8/2008 Isawa ..... A63H 27/12  
446/37  
8,147,289 B1 \* 4/2012 Lee ..... A63H 27/12  
446/36  
D664,214 S \* 7/2012 Yuen ..... D21/441  
D697,145 S \* 1/2014 Wong ..... D21/436  
8,851,841 B2 10/2014 Care  
D740,376 S \* 10/2015 Rehkemper ..... D21/626  
10,054,939 B1 \* 8/2018 Applewhite ..... B64C 11/04  
10,112,694 B2 \* 10/2018 Yan ..... B64C 1/00  
10,259,573 B2 \* 4/2019 Cai ..... B64C 27/14  
D868,902 S \* 12/2019 Zhong ..... D21/440  
2004/0245376 A1 \* 12/2004 Muren ..... B64C 27/467  
244/17.11  
2007/0012818 A1 \* 1/2007 Miyazawa ..... A63H 27/12  
244/17.25  
2016/0001879 A1 1/2016 Johannesson et al.  
2016/0167778 A1 6/2016 Meringer et al.  
2018/0093753 A1 4/2018 Chow  
2018/0257769 A1 9/2018 Goldstein  
2019/0055003 A1 2/2019 Luo et al.  
2019/0071178 A1 3/2019 Caubel

## OTHER PUBLICATIONS

U.S. Appl. No. 16/138,017, Non-Final Office Action, dated Nov. 13,  
2019, United States Patent and Trademark Office.

\* cited by examiner

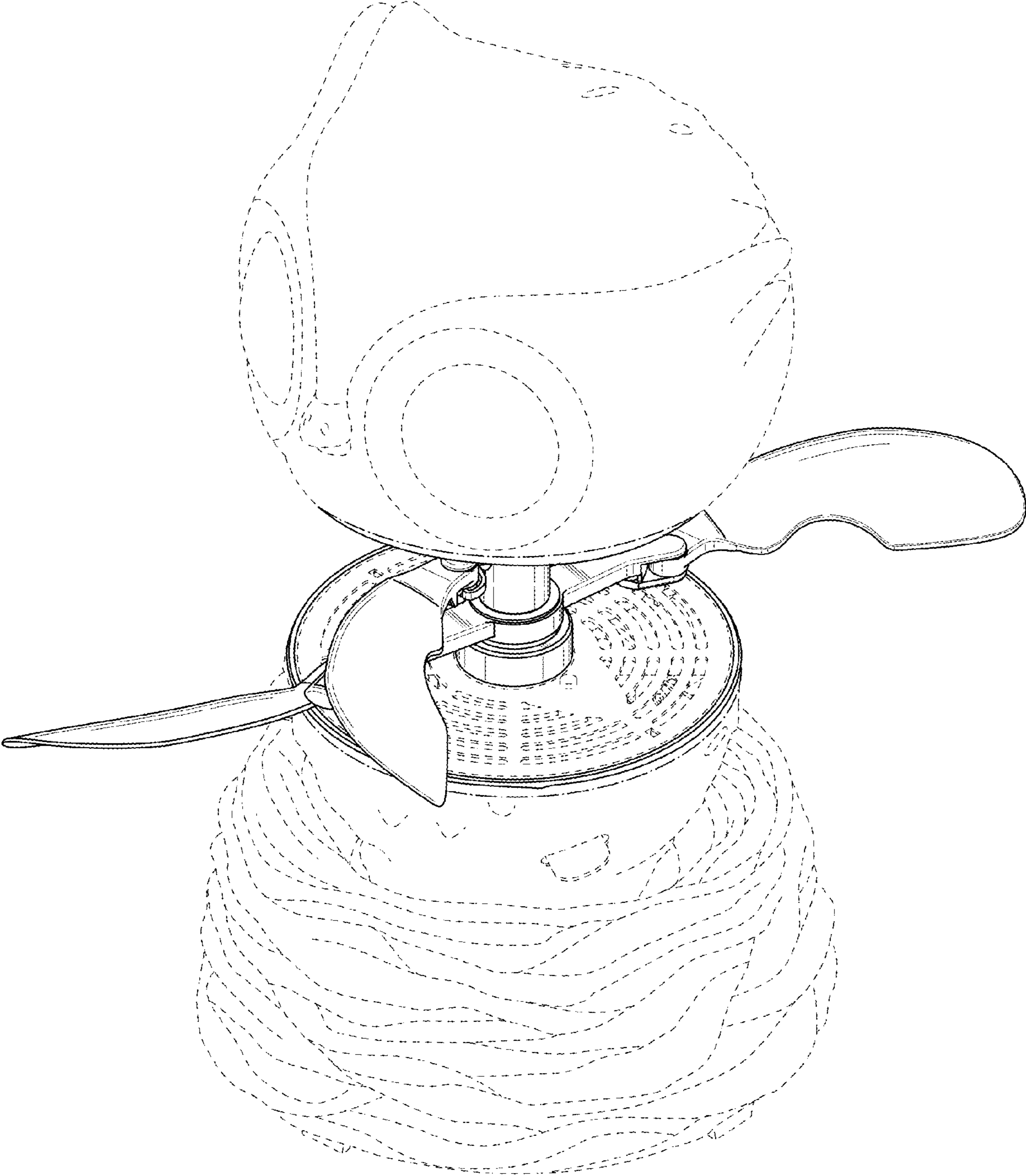

FIG. 1

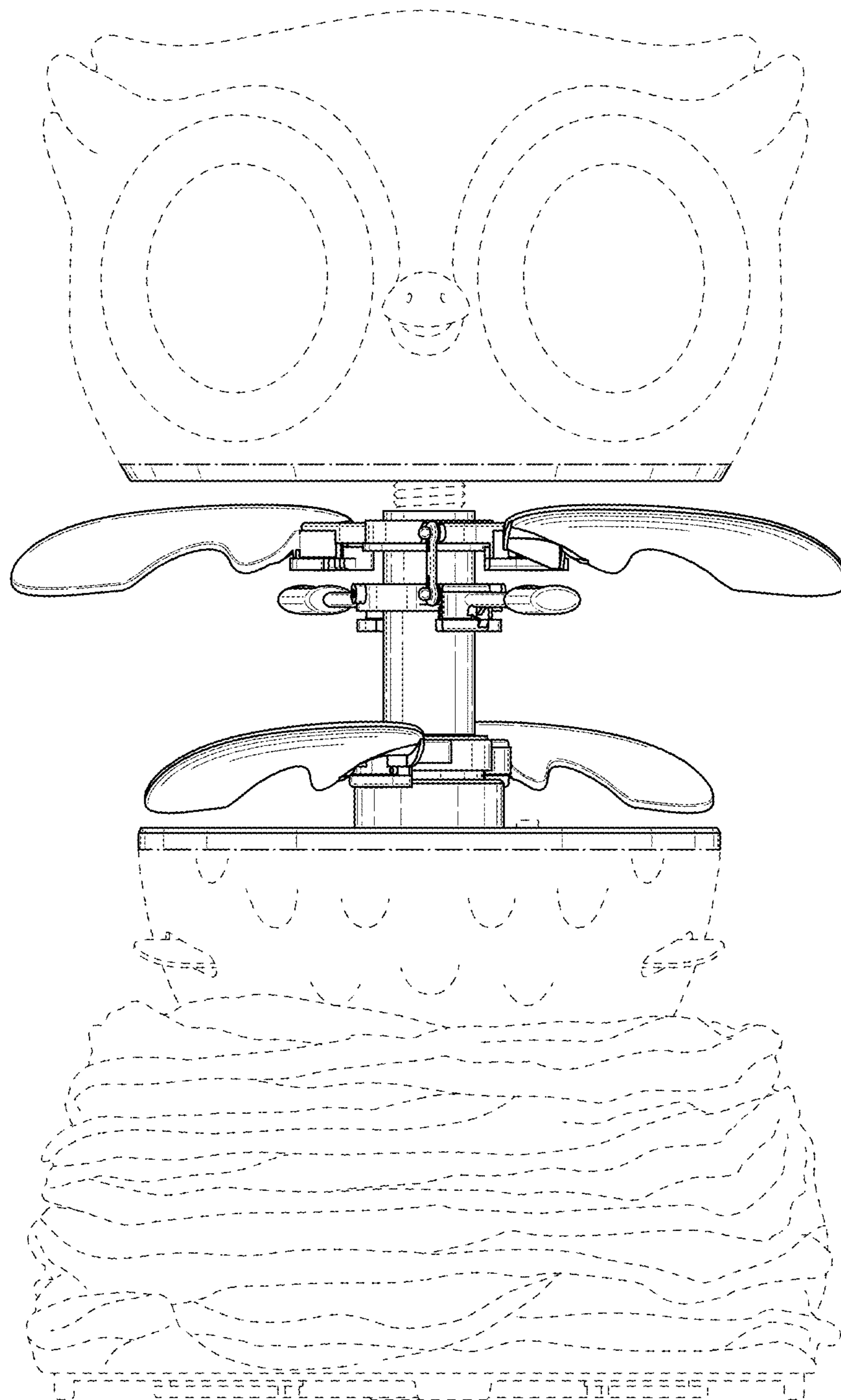

FIG. 2

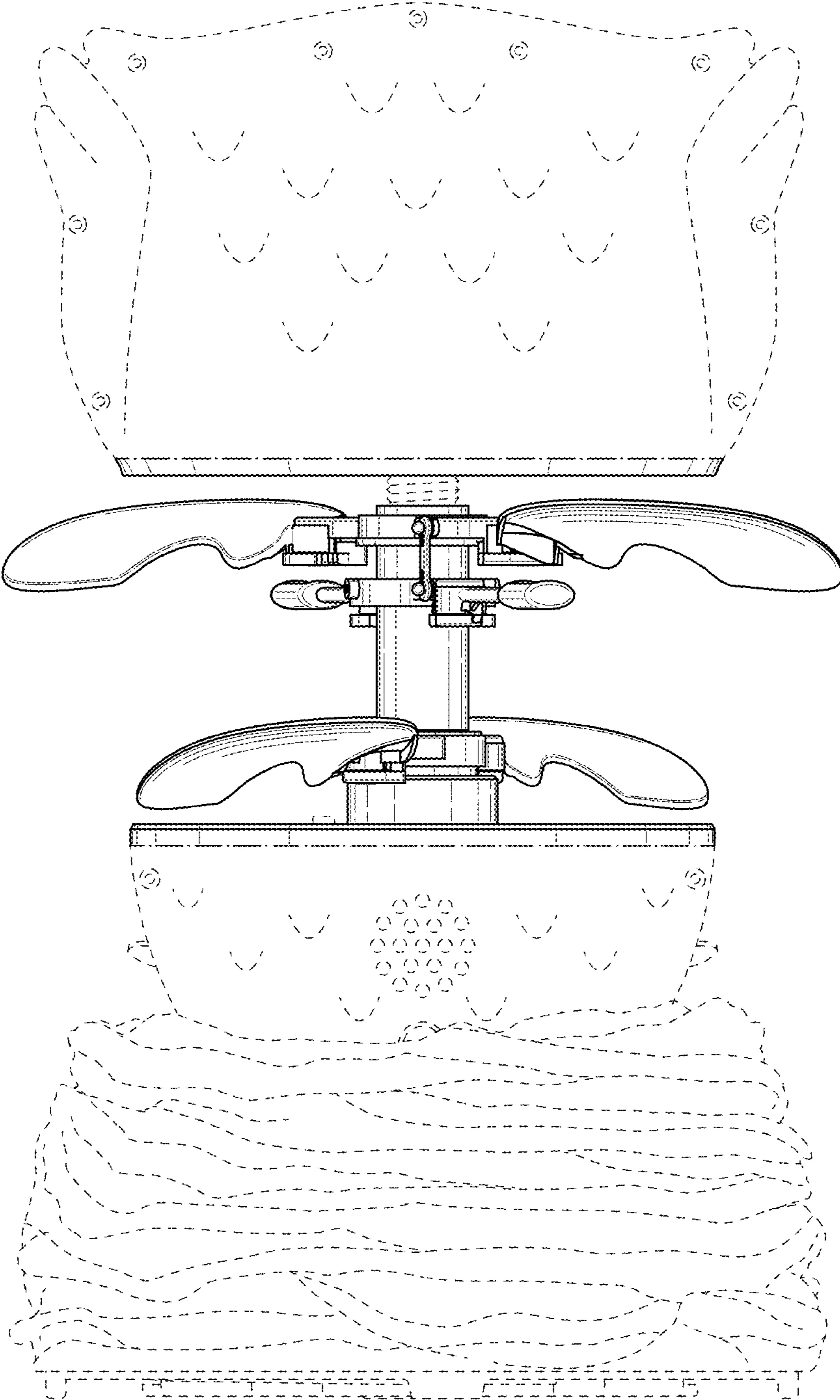

FIG. 3

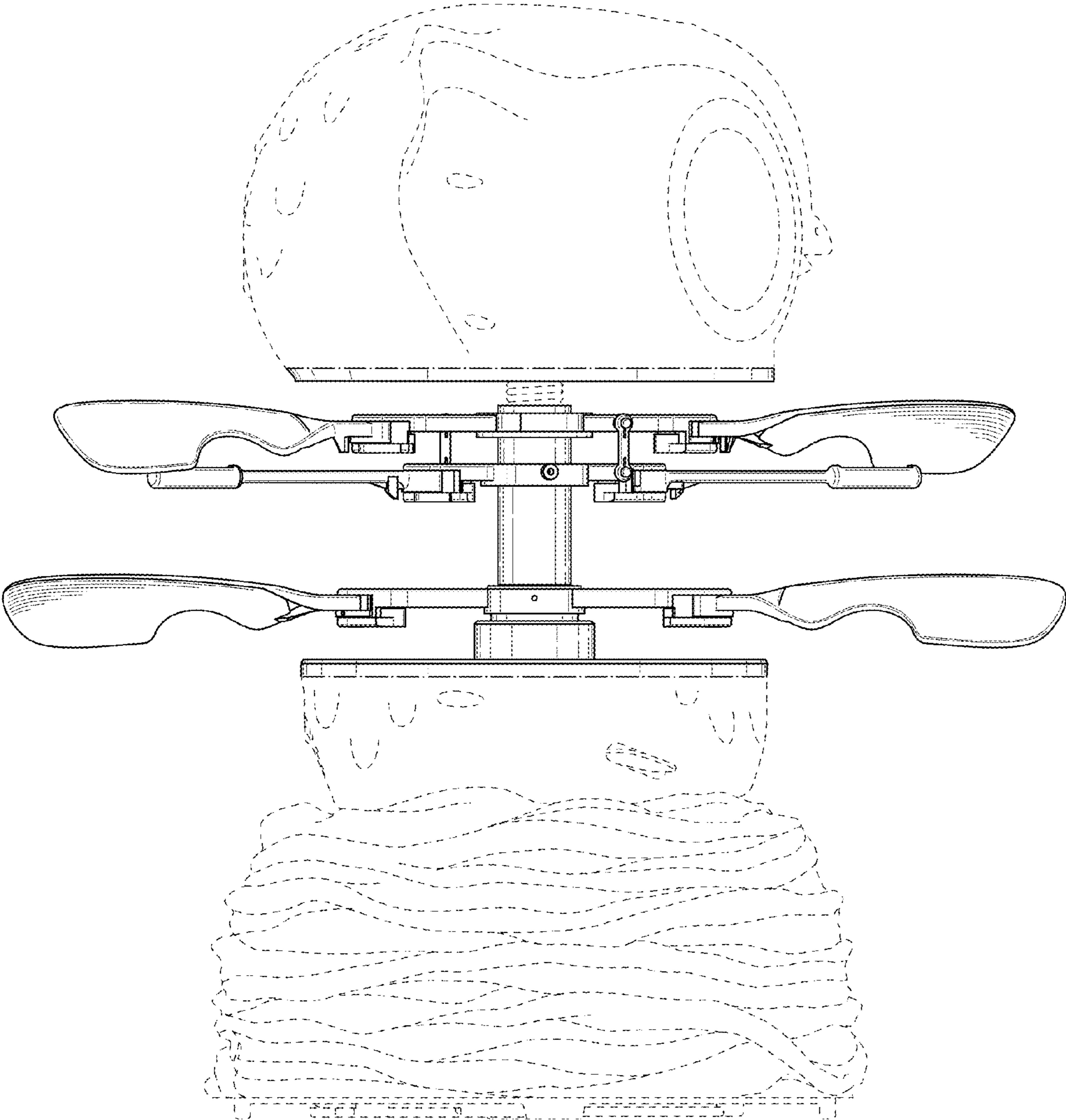
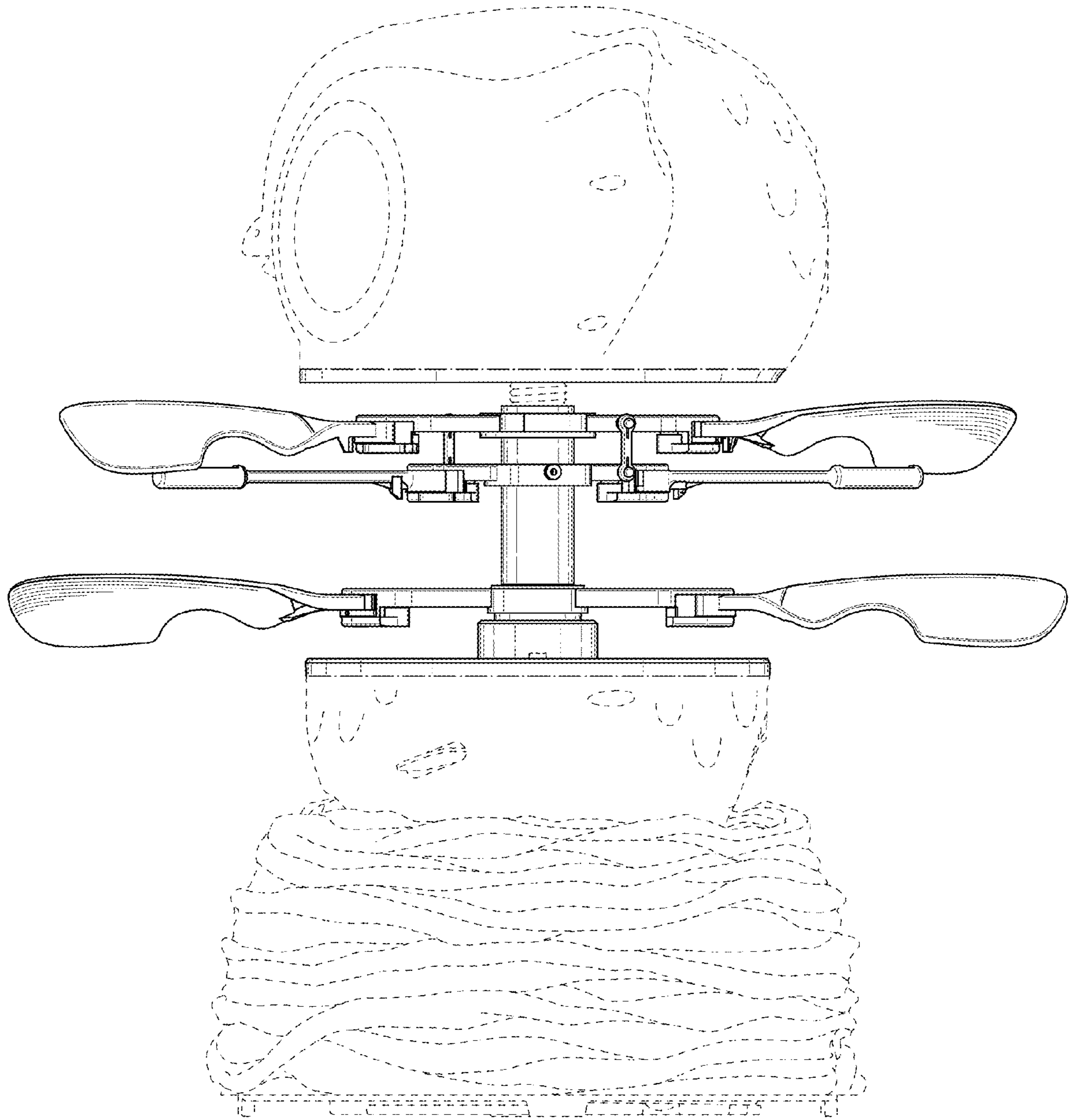
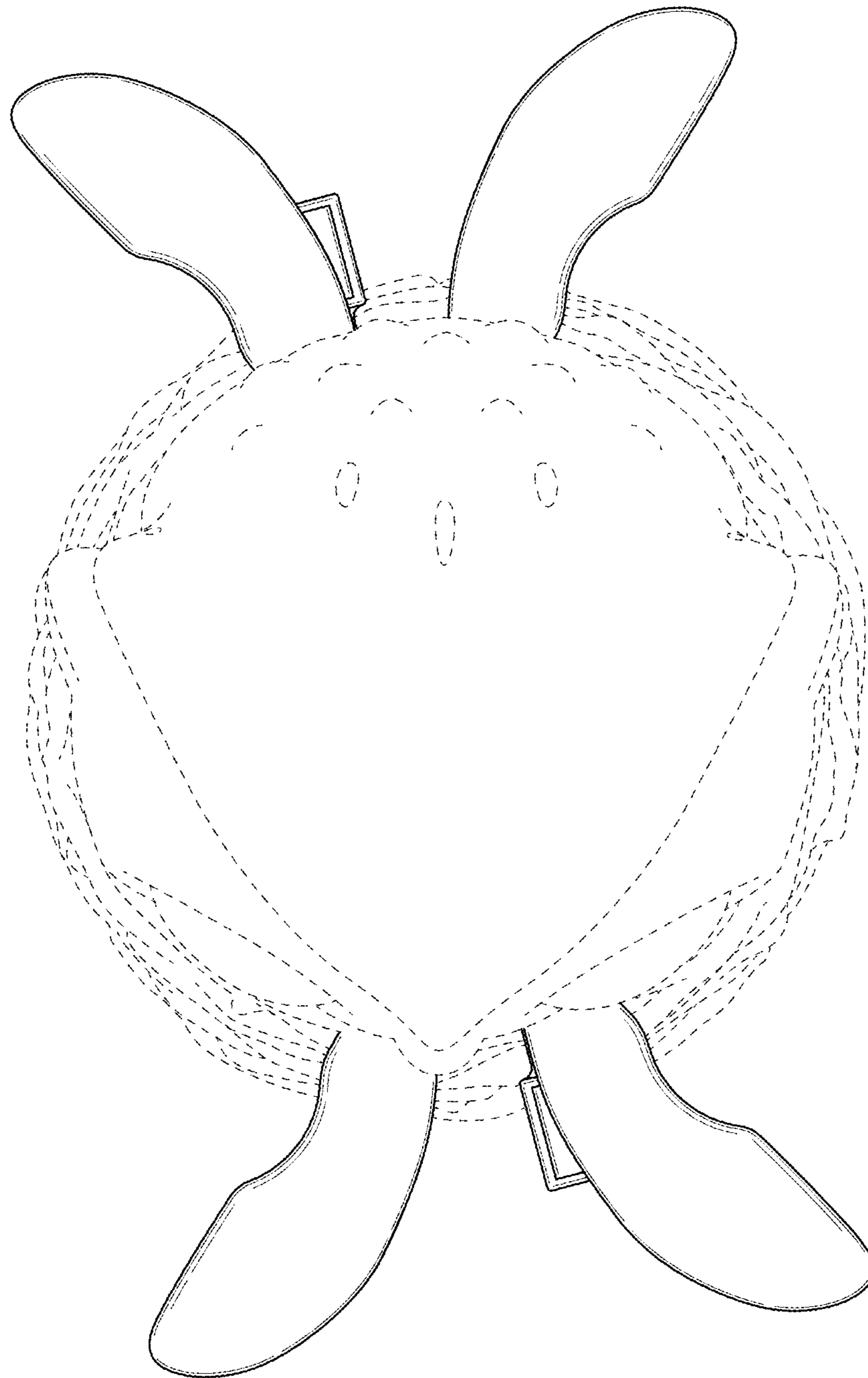

FIG. 4

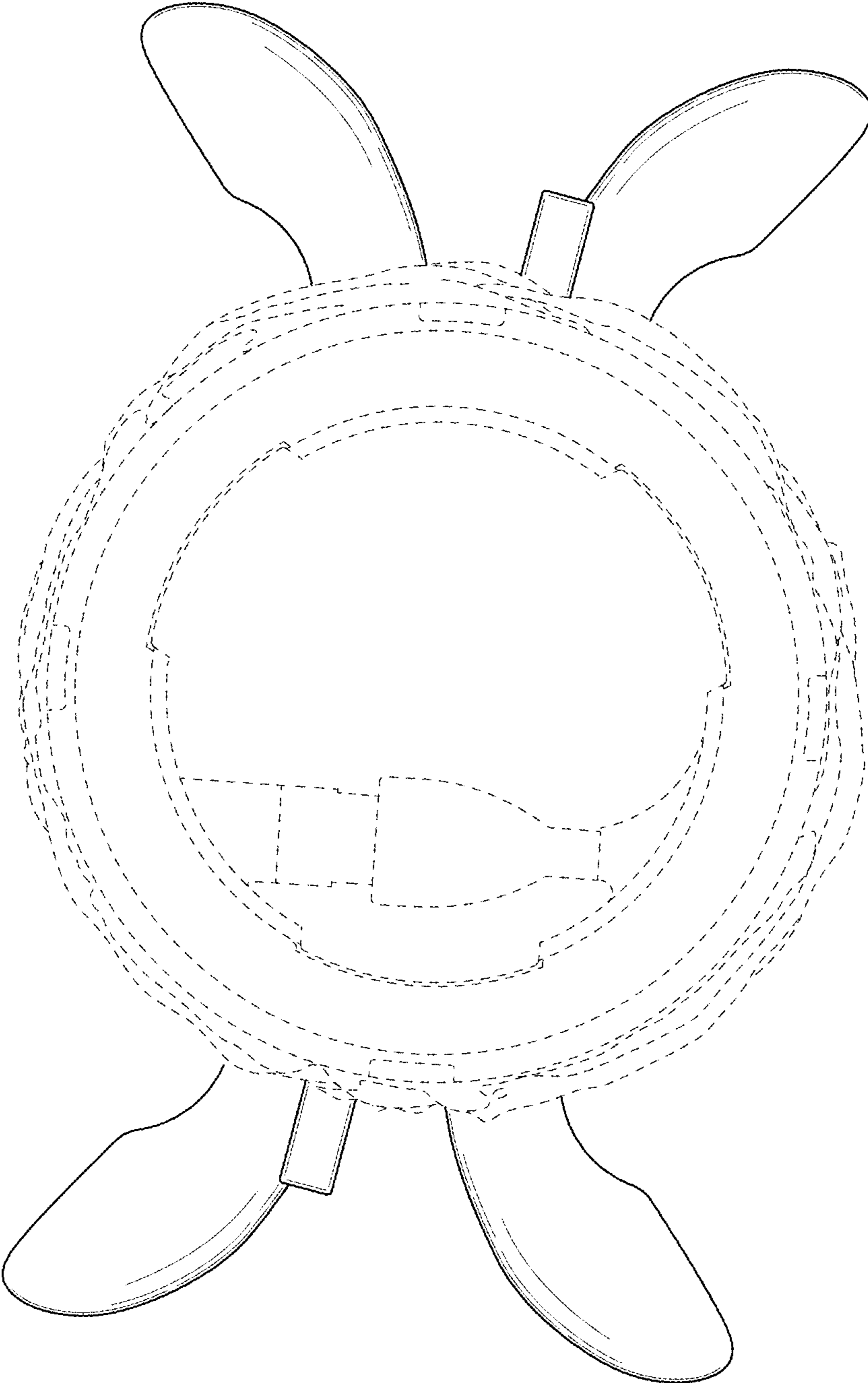

**FIG. 5**



**FIG. 6**





**FIG. 7**