



US00D920389S

(12) **United States Design Patent** (10) **Patent No.:** **US D920,389 S**  
**Yaste et al.** (45) **Date of Patent:** **\*\* May 25, 2021**

(54) **CRANE CAB INTERIOR COMPONENT**

(56) **References Cited**

(71) Applicant: **Link-Belt Cranes, L.P., LLLP**,  
Lexington, KY (US)

(72) Inventors: **Steven Yaste**, Lexington, KY (US);  
**Brian Smoot**, Versailles, KY (US);  
**Richard Shultz**, Carlisle, KY (US)

(73) Assignee: **Link-Belt Cranes, L.P., LLLP**,  
Lexington, KY (US)

U.S. PATENT DOCUMENTS

D636,794	S	*	4/2011	Ono	.....	D15/28
D667,026	S	*	9/2012	Stimel, Jr.	.....	D15/28
D667,849	S	*	9/2012	Stimel, Jr.	.....	D15/28
D673,184	S	*	12/2012	Stimel, Jr.	.....	D15/28
D678,917	S	*	3/2013	Hagura	.....	D15/28
D682,892	S	*	5/2013	Takagi	.....	D15/28
D685,006	S	*	6/2013	Hagura	.....	D15/28
D727,978	S	*	4/2015	Higuchi	.....	D15/28
D816,730	S	*	5/2018	Diebold	.....	D15/28
D856,379	S	*	8/2019	Ninomiya	.....	D15/28
D887,458	S	*	6/2020	Adachi	.....	D15/28

(\*\*) Term: **15 Years**

\* cited by examiner

(21) Appl. No.: **29/754,860**

*Primary Examiner* — Mark A Goodwin

(22) Filed: **Oct. 15, 2020**

(74) *Attorney, Agent, or Firm* — King & Schickli, PLLC

**Related U.S. Application Data**

(62) Division of application No. 29/627,111, filed on Nov. 22, 2017, now Pat. No. Des. 908,145.

(51) **LOC (13) Cl.** ..... **15-03**

(52) **U.S. Cl.**  
USPC ..... **D15/30**; D15/28

(58) **Field of Classification Search**  
USPC ..... D15/10, 22–26, 28, 30; 180/89.1, 89.12,  
180/89.13, 900, 9.1, 9.2, 9.62; 37/379;  
414/694, 699, 722–724, 660, 685, 698,  
414/719, 743  
CPC ..... E02F 3/32; E02F 3/76; E02F 3/40; E02F  
3/325; E02F 3/352; E02F 3/384; E02F  
3/425; E02F 3/437; E02F 3/627; E02F  
3/964; E02F 9/163; E02F 9/0858; E02F  
9/0875; E02F 9/2045; E02F 9/006; E02F  
9/0808; E02F 9/0833; E02F 9/2004; E02F  
9/207; E02F 9/2091; E02F 9/2246; E02F  
9/2292

See application file for complete search history.

(57) **CLAIM**

The ornamental design for a crane cab interior component, as shown and described.

**DESCRIPTION**

FIG. 1 is a top perspective view of a crane cab interior component showing our new design in an assembled condition;

FIG. 2 is a front perspective view of a crane cab interior component showing our new design in an unassembled condition set apart from the cab of FIG. 1 for ease of illustration;

FIG. 3 is a rear view thereof;

FIG. 4 is a right side view thereof;

FIG. 5 is a front view thereof;

FIG. 6 is a left side view thereof;

FIG. 7 is a top view thereof; and,

FIG. 8 is a bottom view thereof.

The broken line showing of the cab in FIG. 1 is for environmental purposes only and forms no part of the claimed design. The broken line showing in FIGS. 2-8 is included for the purpose of illustrating portions of the crane cab interior component and forms no part of the claimed design.

**1 Claim, 7 Drawing Sheets**

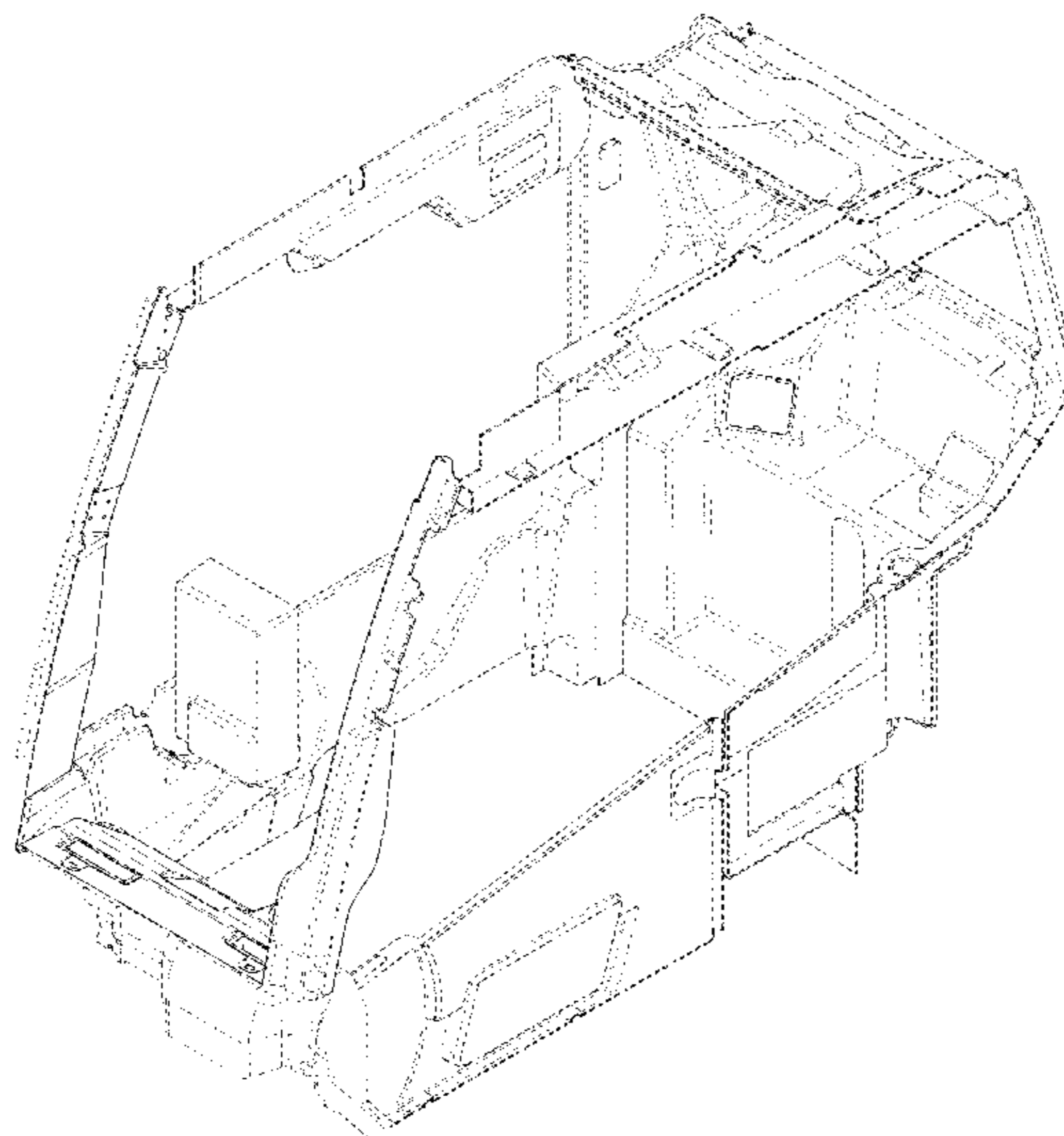

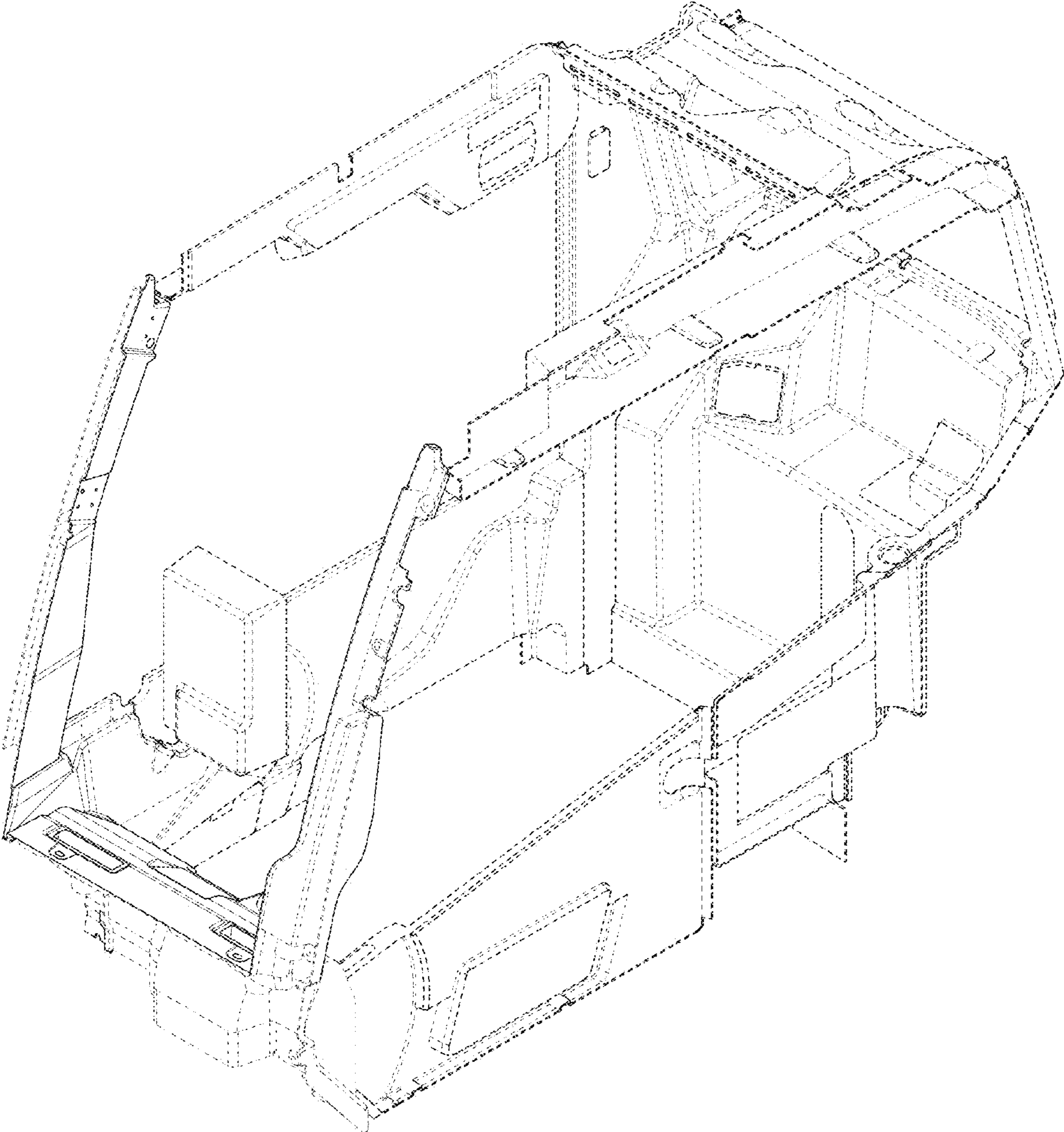

FIG. 1



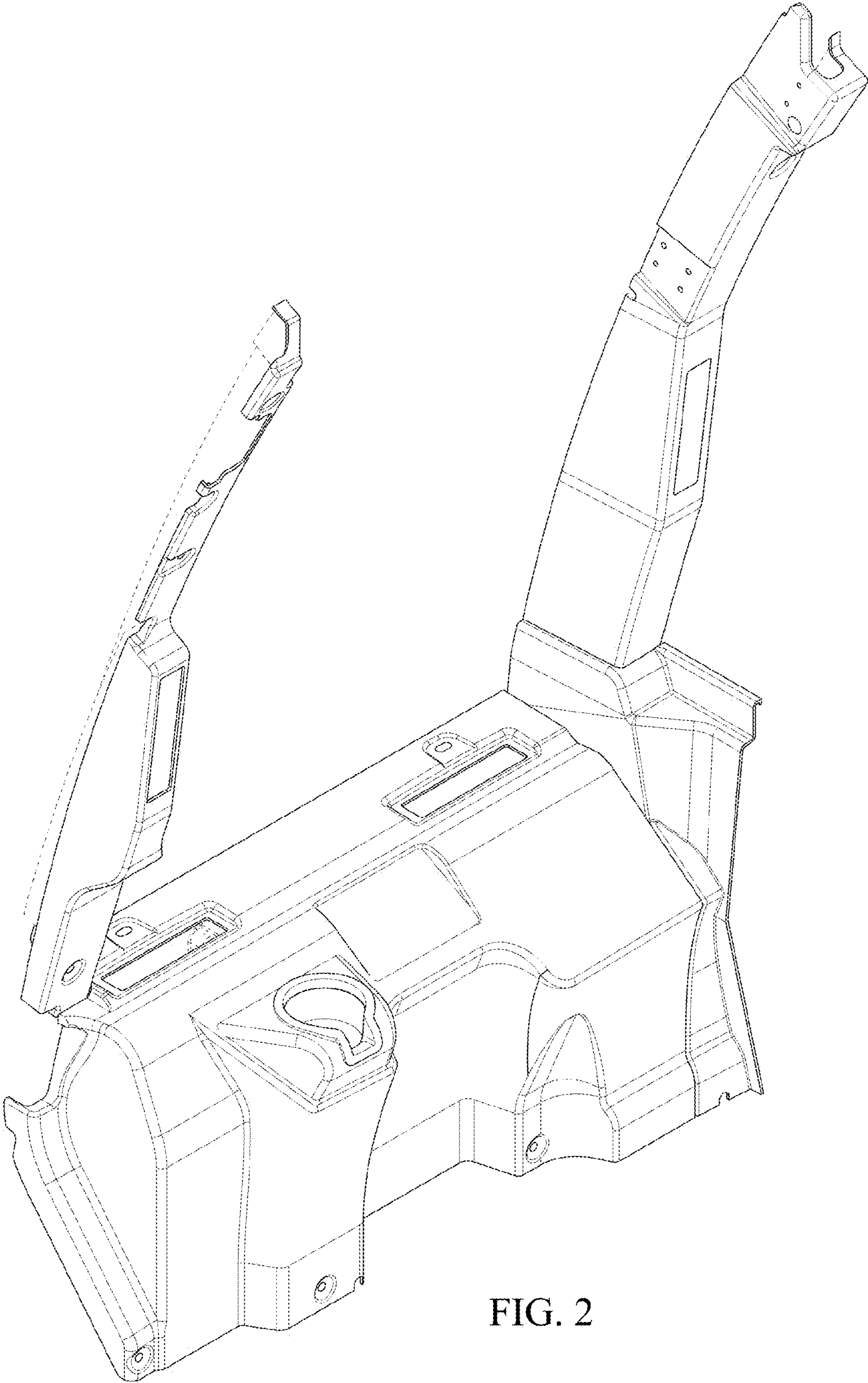

FIG. 2

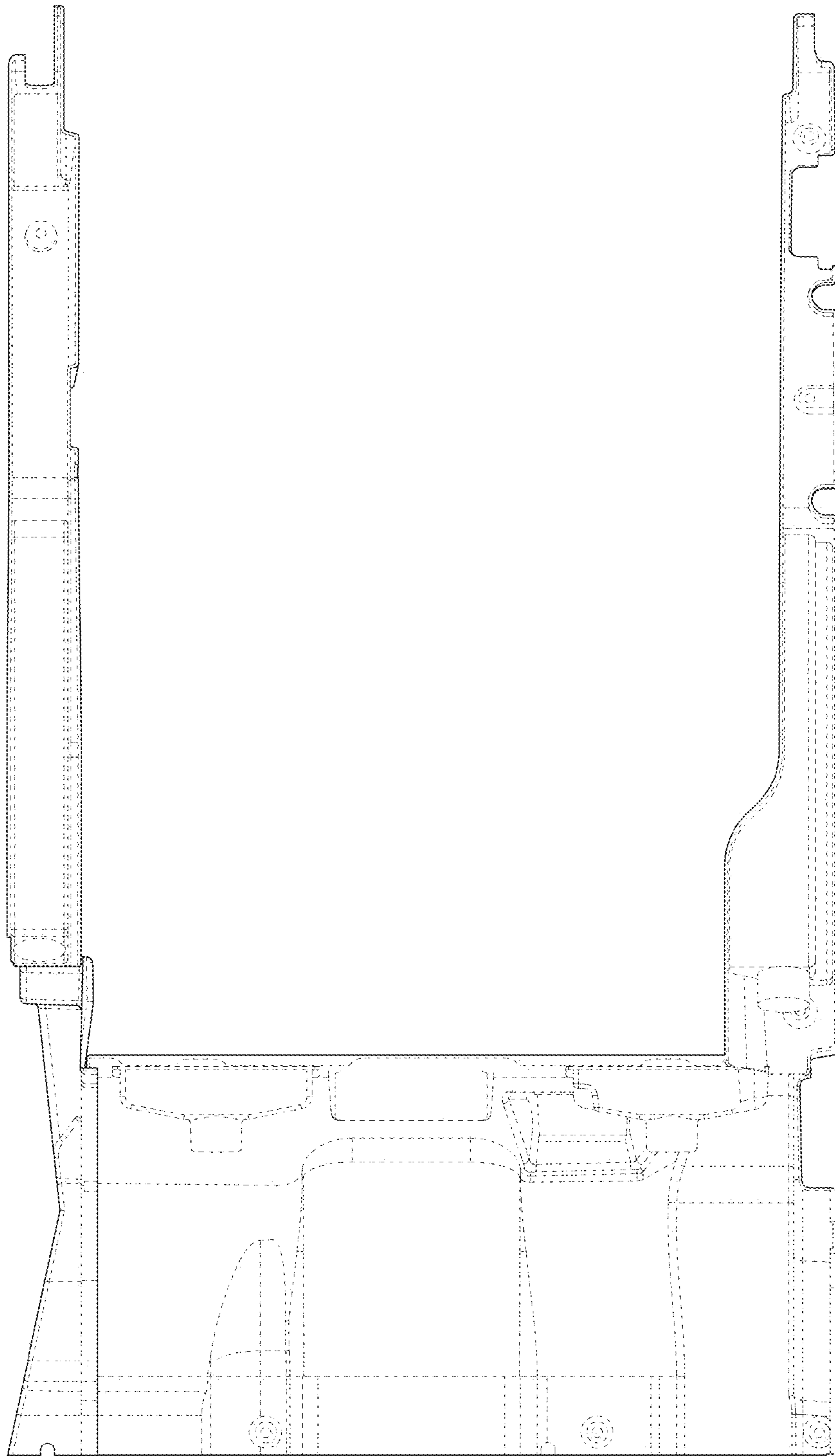

FIG. 3

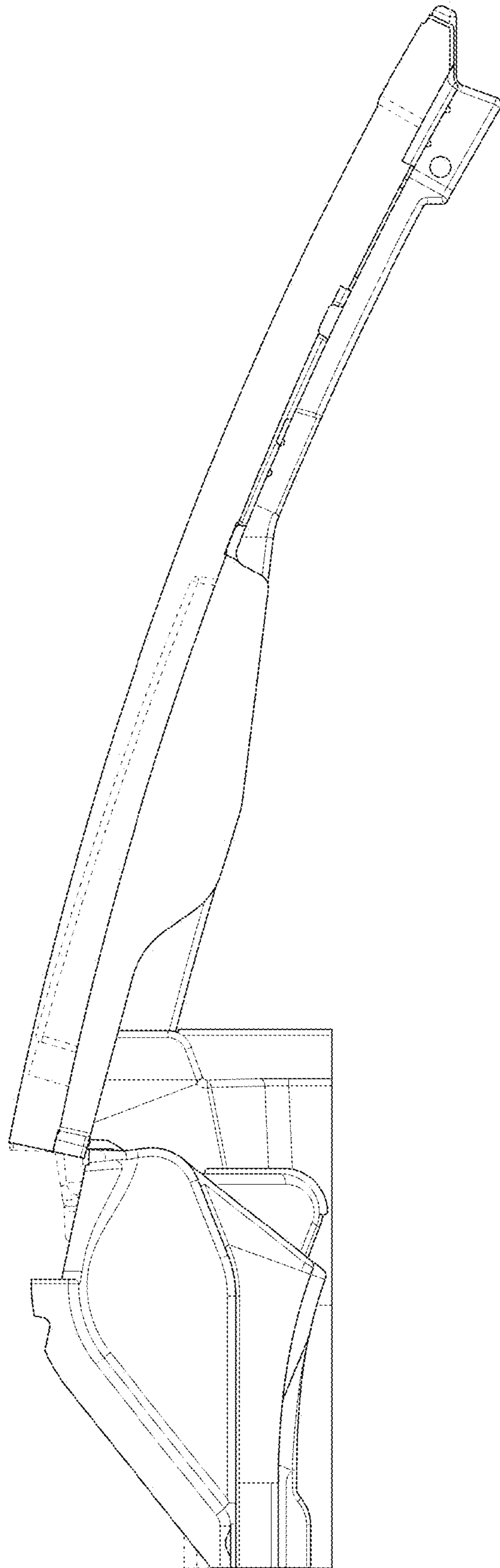

FIG. 4

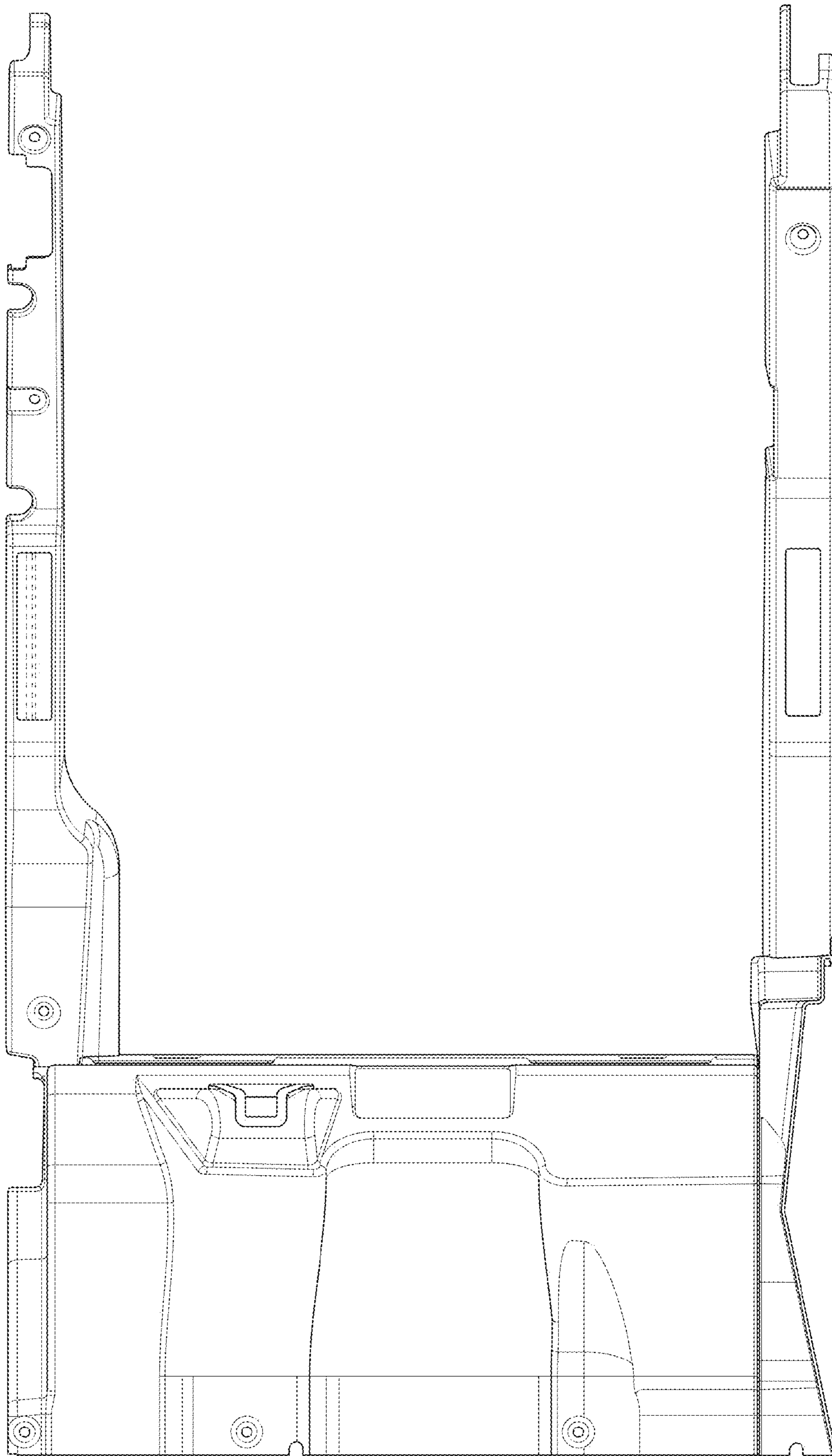

FIG. 5

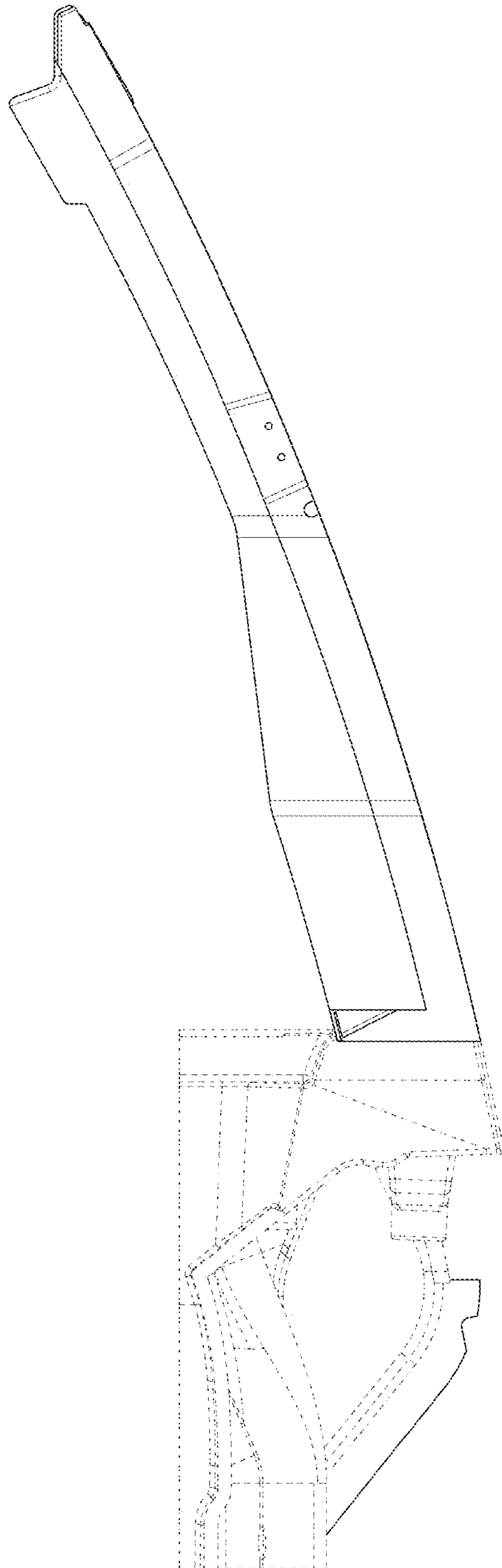

FIG. 6



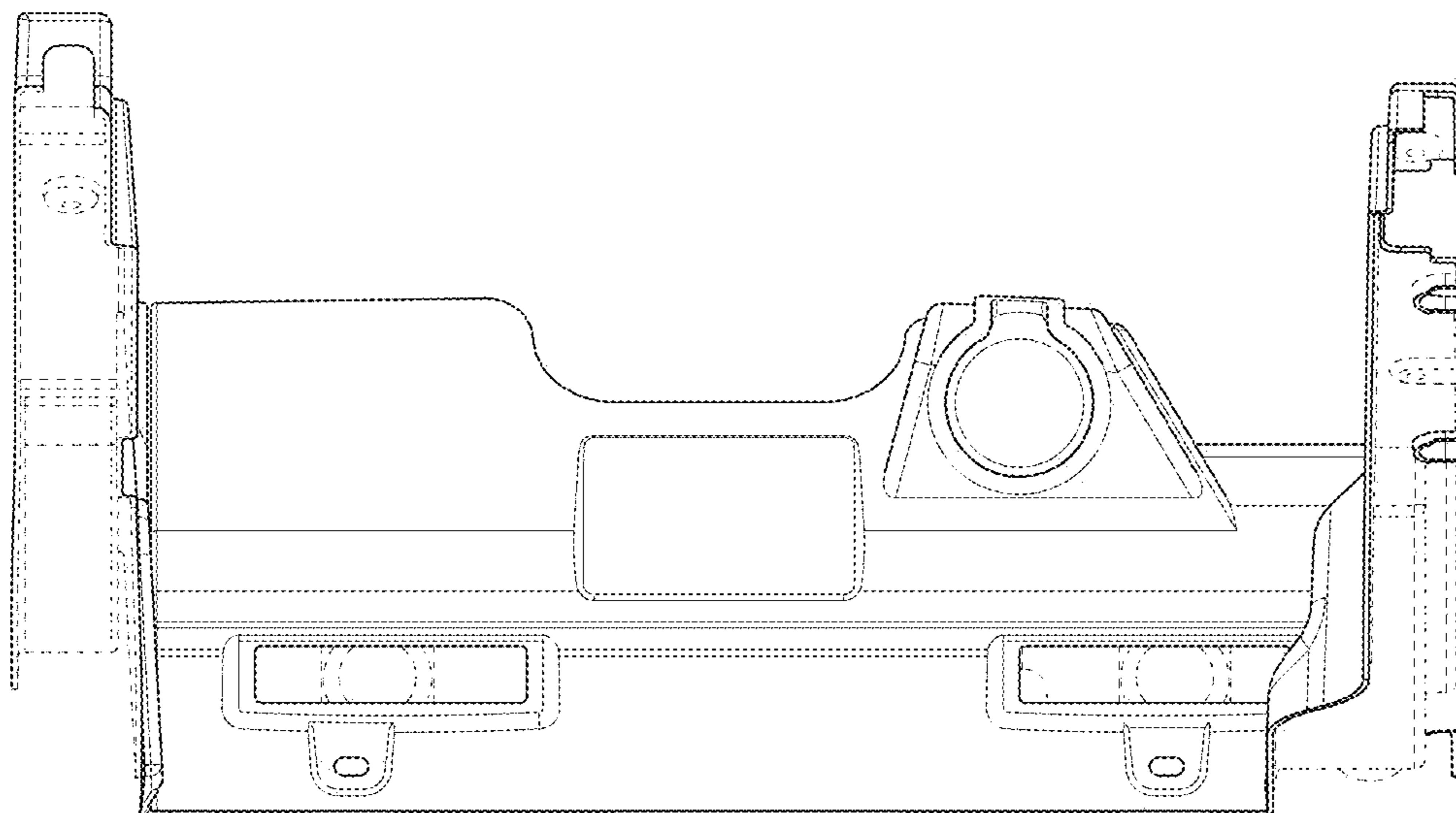

FIG. 7

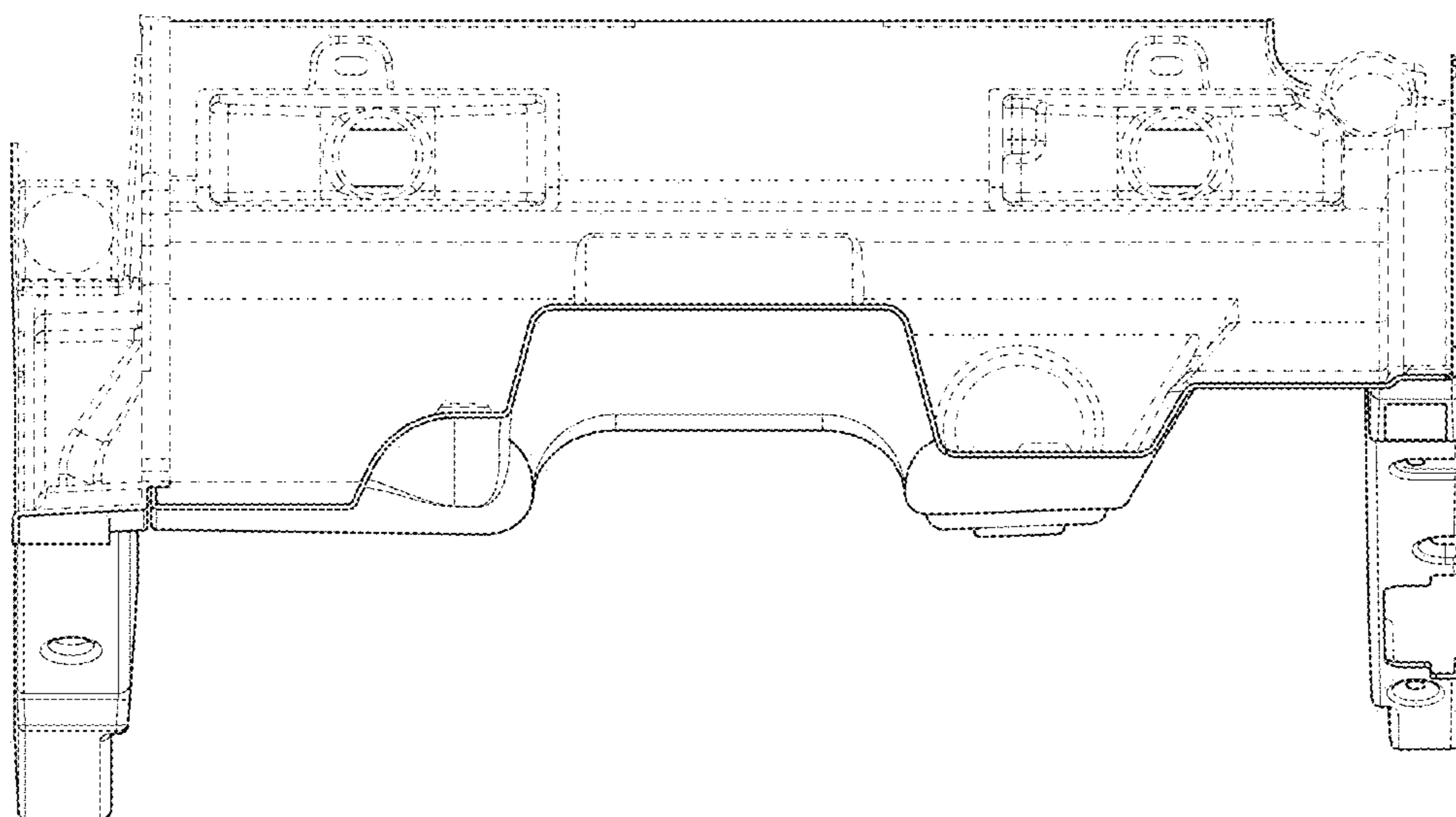

FIG. 8