



US00D920213S

(12) **United States Design Patent** (10) **Patent No.:** **US D920,213 S**
Carpenter et al. (45) **Date of Patent:** **** May 25, 2021**

(54) **AIRCRAFT**

(71) Applicant: **Bell Textron Inc.**, Fort Worth, TX (US)

(72) Inventors: **Joseph Richard Carpenter**, Kennedale, TX (US); **Timothy Carr**, Fort Worth, TX (US); **Matthew E. Louis**, Fort Worth, TX (US); **Steve Michael Loveland**, Fort Worth, TX (US)

(73) Assignee: **BELL TEXTRON INC.**, Fort Worth, TX (US)

(**) Term: **15 Years**

(21) Appl. No.: **29/719,437**

(22) Filed: **Jan. 3, 2020**

(51) **LOC (13) Cl.** **12-02**

(52) **U.S. Cl.**
USPC **D12/328**

(58) **Field of Classification Search**
USPC D12/1, 2, 3, 4, 16.1, 174, 319-345;
D21/436-455; D13/109
CPC B64C 29/0033; B64C 2201/021; B64C
29/02; B64C 2201/088; B64C 2201/104;
B64C 2201/141

See application file for complete search history.

(56) **References Cited**

U.S. PATENT DOCUMENTS

| | | | | | |
|--------------|------|--------|----------------|-------|--------------|
| 10,562,620 | B2 * | 2/2020 | Kroo | | B64C 29/0033 |
| D887,948 | S * | 6/2020 | Loveland | | D12/328 |
| 2012/0043413 | A1 * | 2/2012 | Smith | | B64C 29/0033 |
| | | | | | 244/12.4 |
| 2012/0234968 | A1 * | 9/2012 | Smith | | B64D 17/64 |
| | | | | | 244/12.3 |
| 2018/0057157 | A1 * | 3/2018 | Groninga | | B64C 27/82 |
| 2019/0291860 | A1 * | 9/2019 | Morgan | | B64D 35/04 |
| 2020/0223530 | A1 * | 7/2020 | Carpenter, Jr. | | B64C 11/46 |
| 2020/0239134 | A1 * | 7/2020 | Robertson | | B64C 29/0033 |

(Continued)

OTHER PUBLICATIONS

Bell Reveals the City of the Future at CES 2020 (article) [Jan. 6, 2020] found online [Nov. 30, 2020]—<https://news.bellflight.com/en-US/184550-bell-reveals-the-city-of-the-future-at-ces-2020>.*

Primary Examiner — John A Voytek

(74) *Attorney, Agent, or Firm* — Patent Capital Group

(57) **CLAIM**

The ornamental design for an aircraft, substantially as shown and described.

DESCRIPTION

FIG. 1 is a perspective view of our new design for an aircraft;
FIG. 2 is a side view in elevation of the aircraft as shown in FIG. 1;
FIG. 3 is a top plan view of the aircraft as shown in FIG. 1;
FIG. 4 is a front elevational view of the aircraft as shown in FIG. 1;
FIG. 5 is a bottom plan view of the aircraft as shown in FIG. 1;
FIG. 6 is a rear elevational view of the aircraft as shown in FIG. 1;
FIG. 7 is a perspective view of our new design for an aircraft in an alternate configuration of use;
FIG. 8 is a side view in elevation of the aircraft as shown in FIG. 7;
FIG. 9 is a top plan view of the aircraft as shown in FIG. 7;
FIG. 10 is a front elevational view of the aircraft as shown in FIG. 7;
FIG. 11 is a bottom plan view of the aircraft as shown in FIG. 7; and,
FIG. 12 is a rear elevational view of the aircraft as shown in FIG. 7.

1 Claim, 12 Drawing Sheets

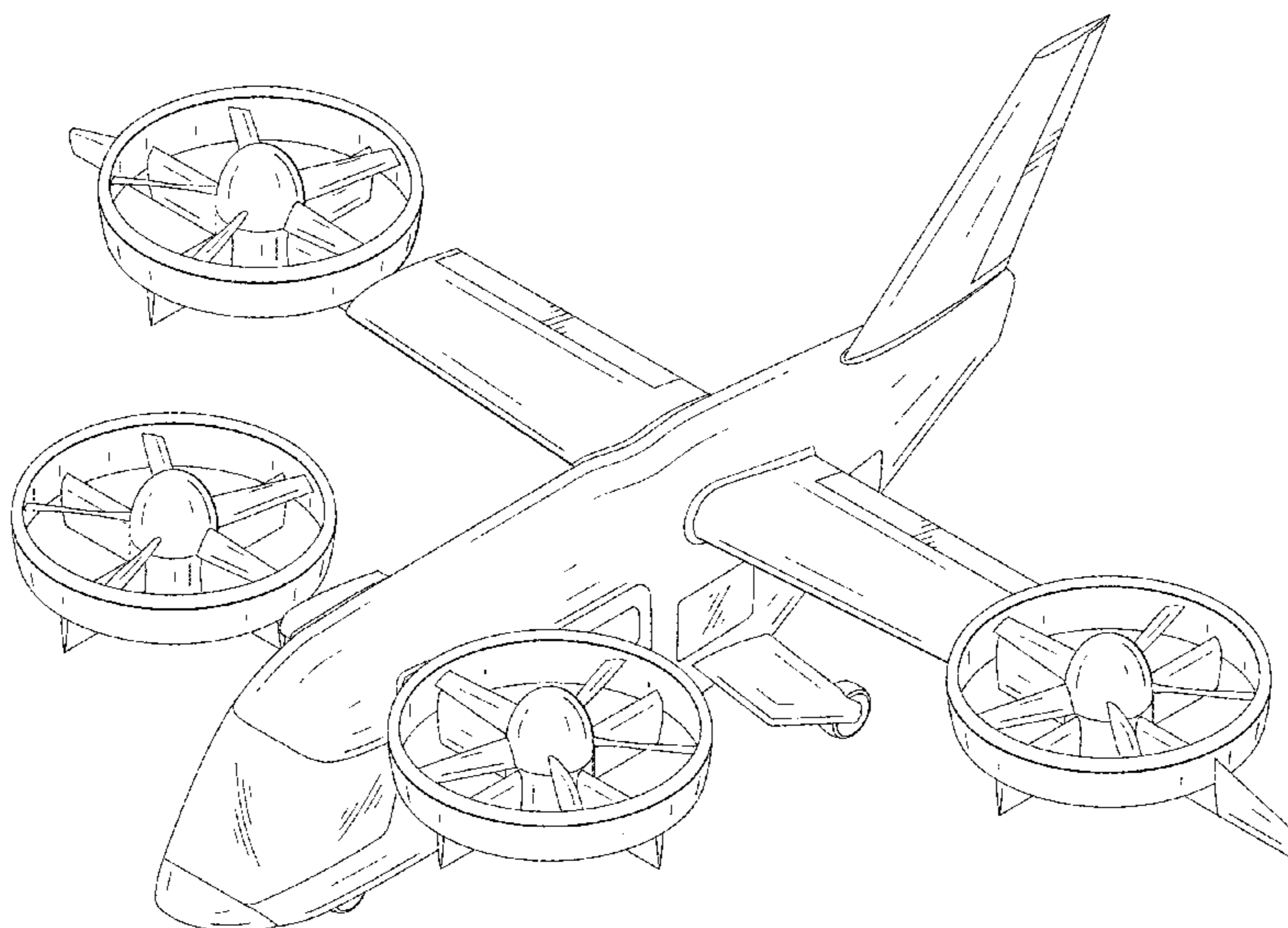

(56)

References Cited

U.S. PATENT DOCUMENTS

2020/0255135 A1* 8/2020 Hong B64C 39/08
2020/0262553 A1* 8/2020 Gomez B64C 39/08

* cited by examiner

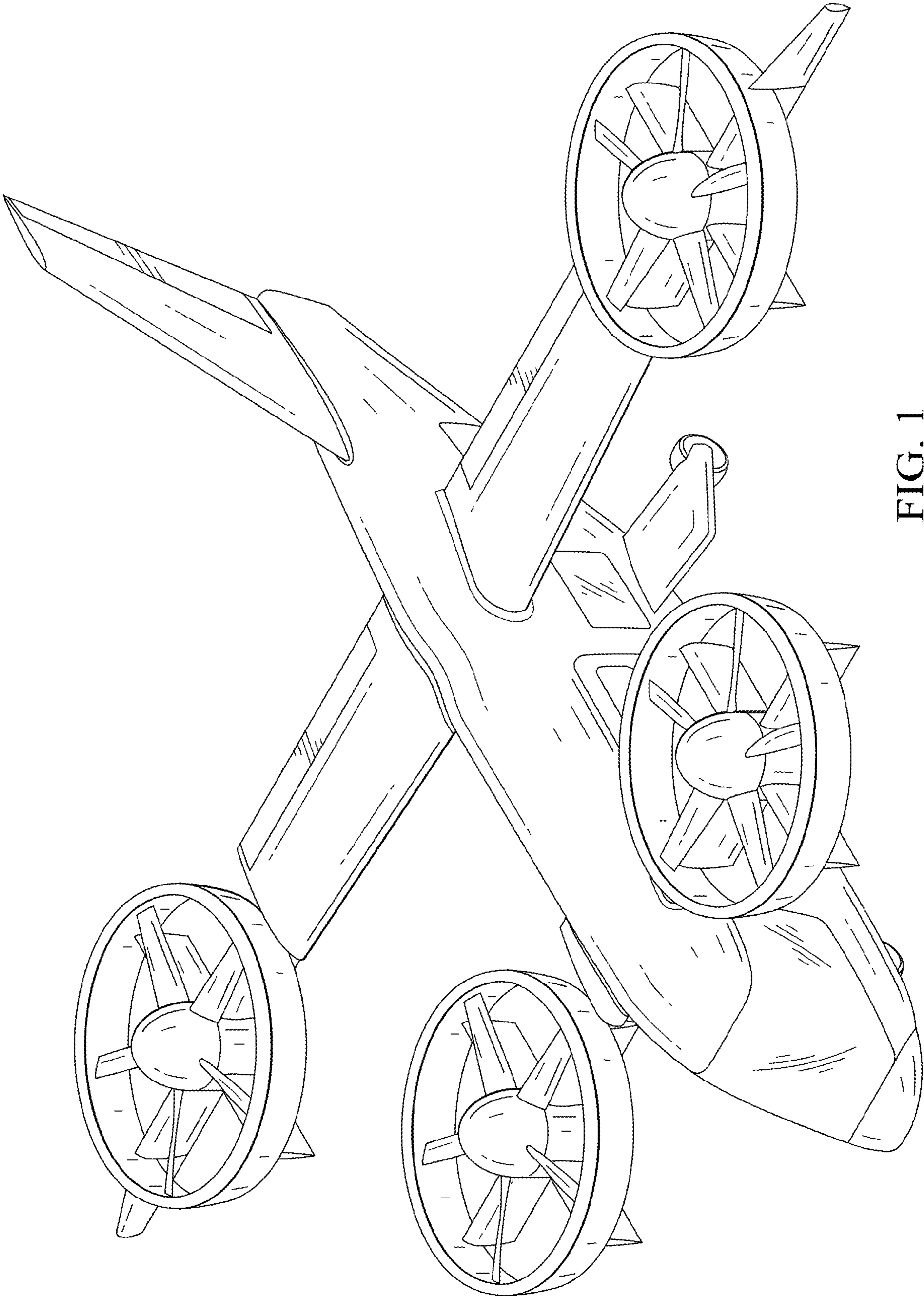

FIG. 1

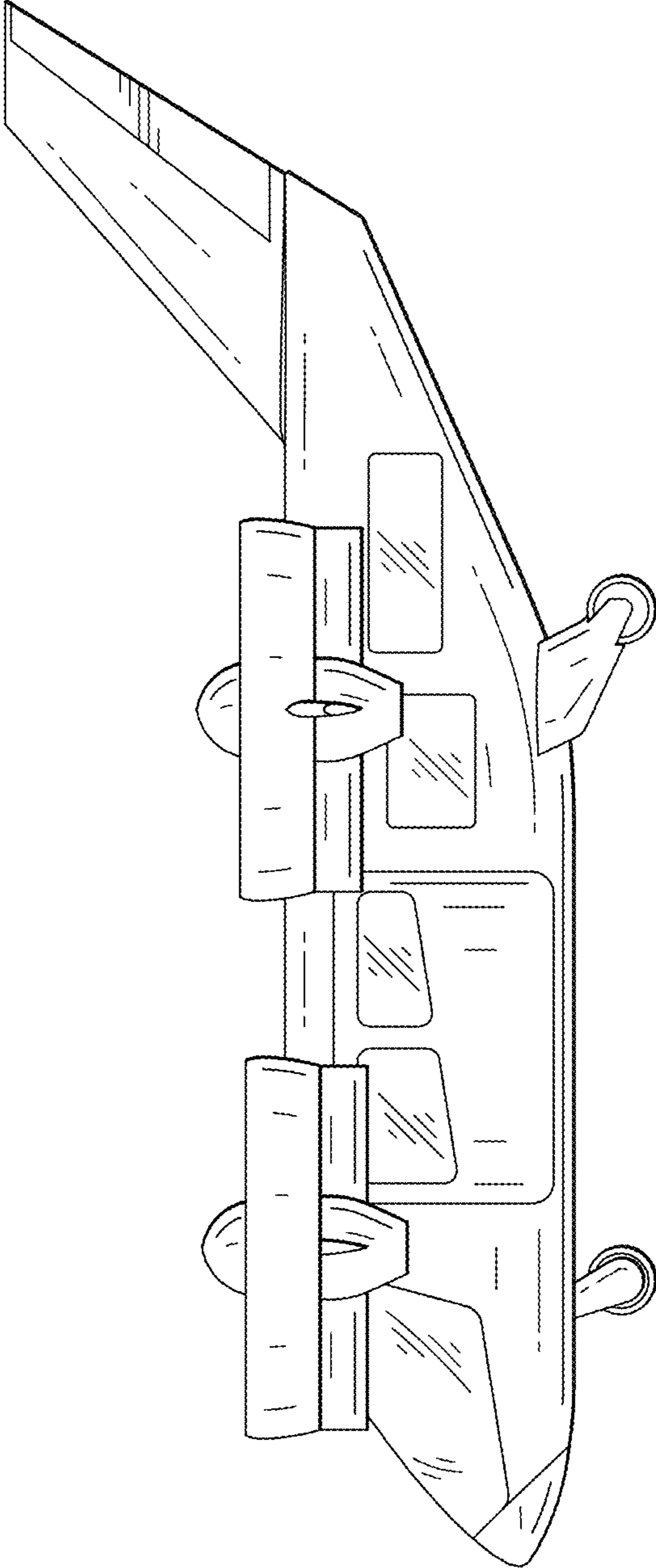

FIG. 2

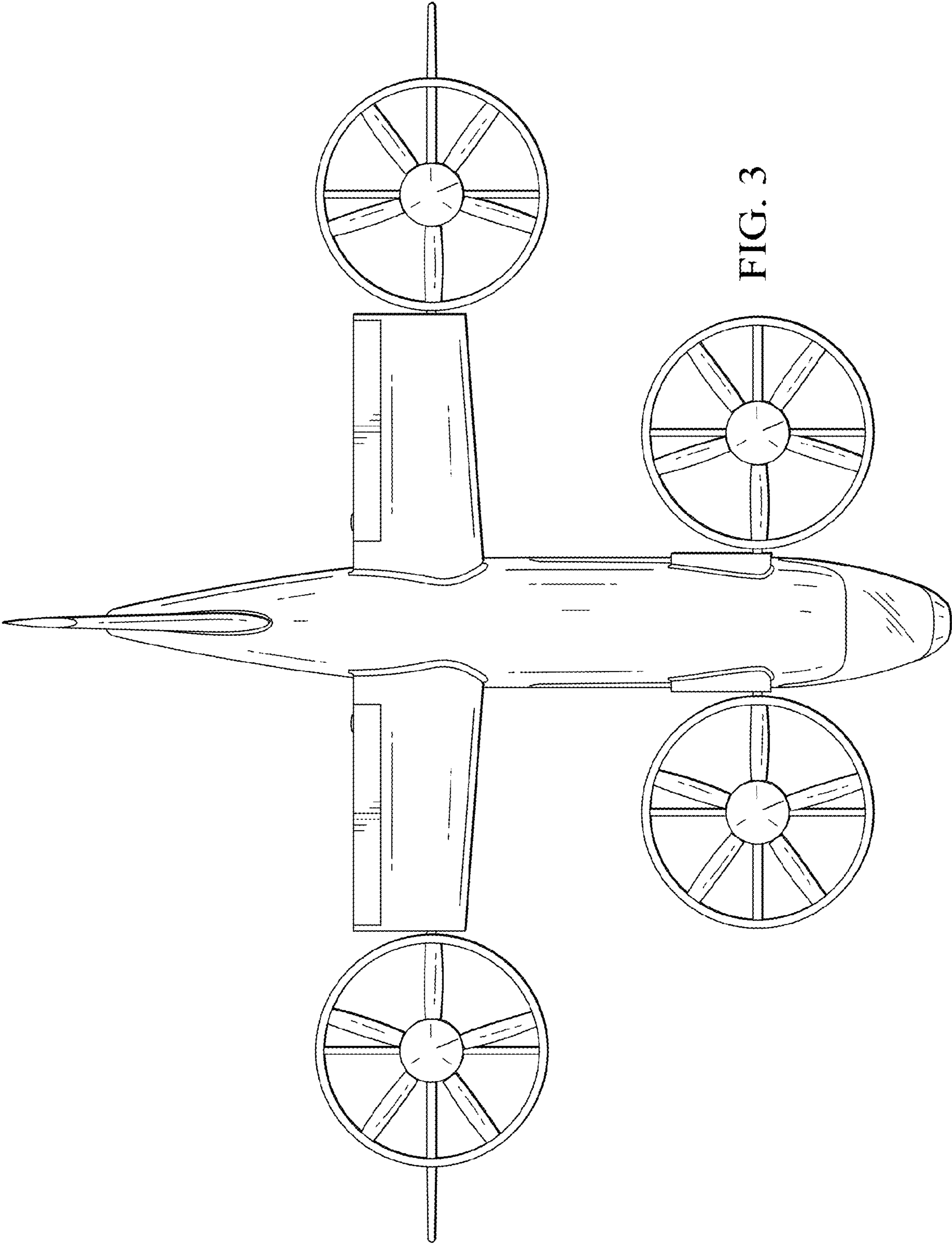

FIG. 3

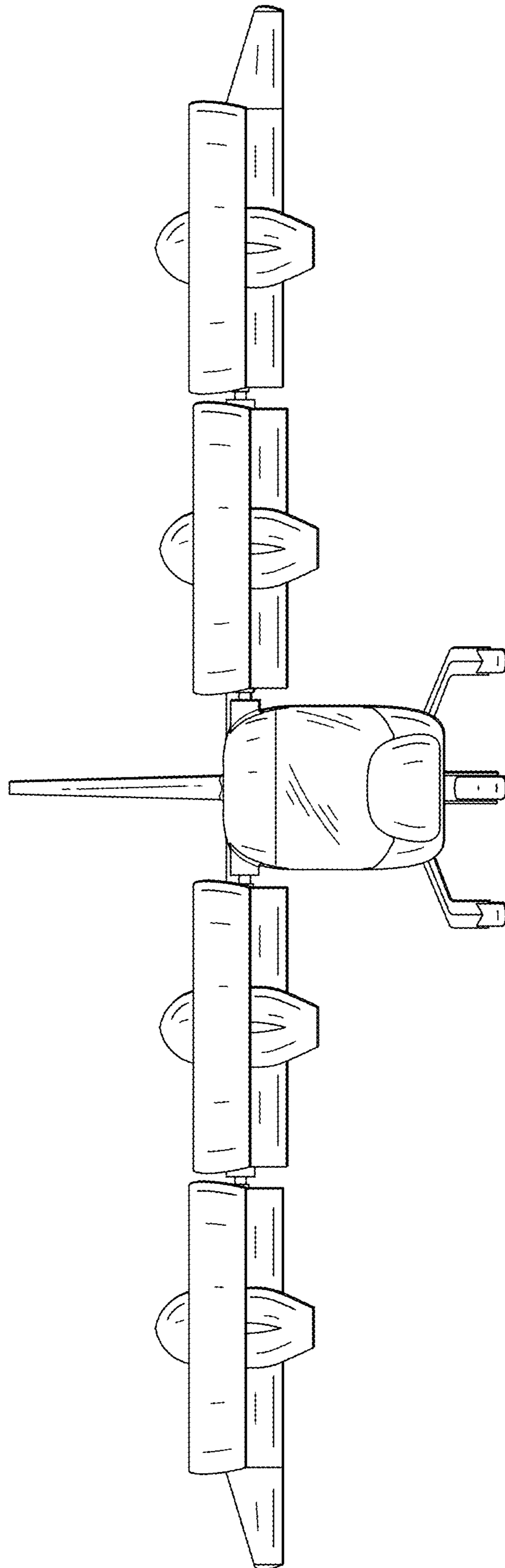

FIG. 4

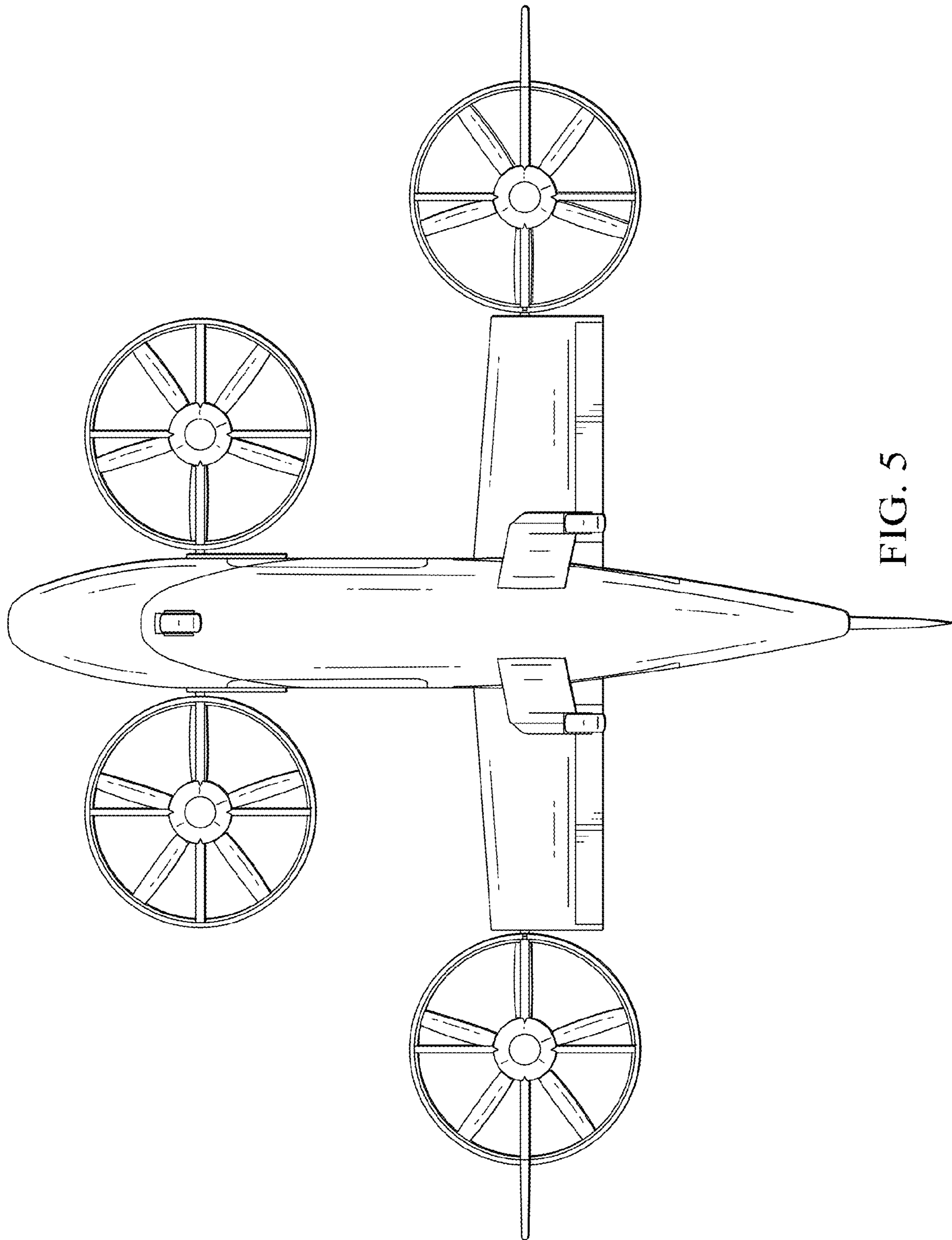

FIG. 5

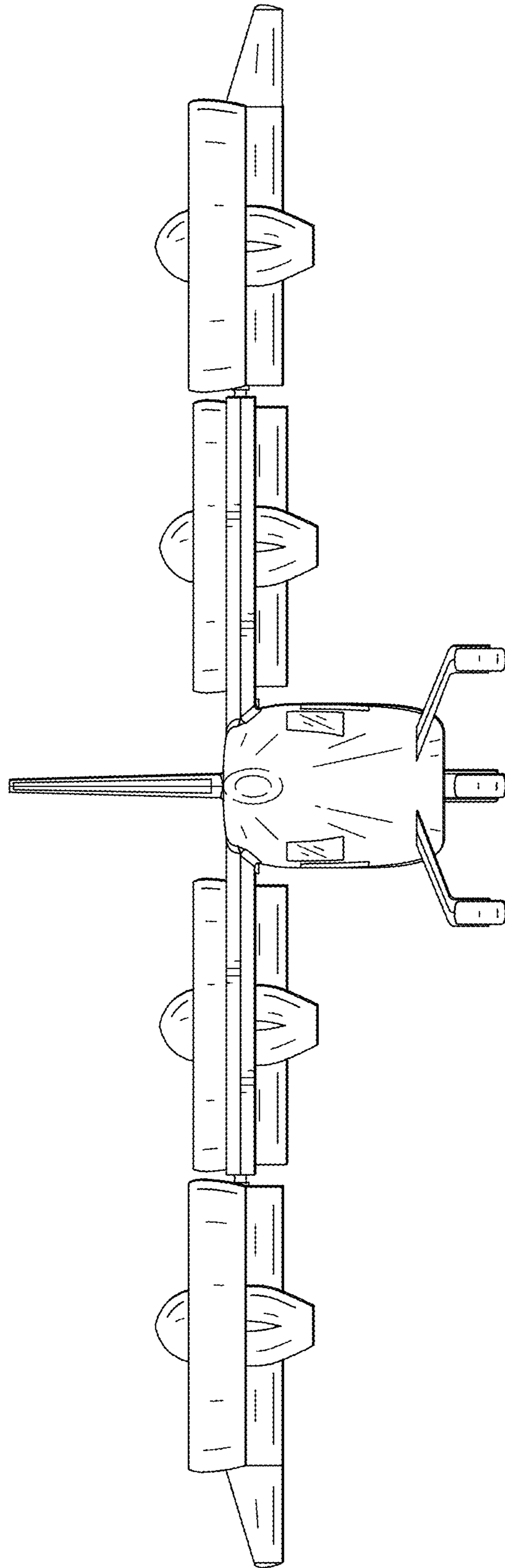

FIG. 6

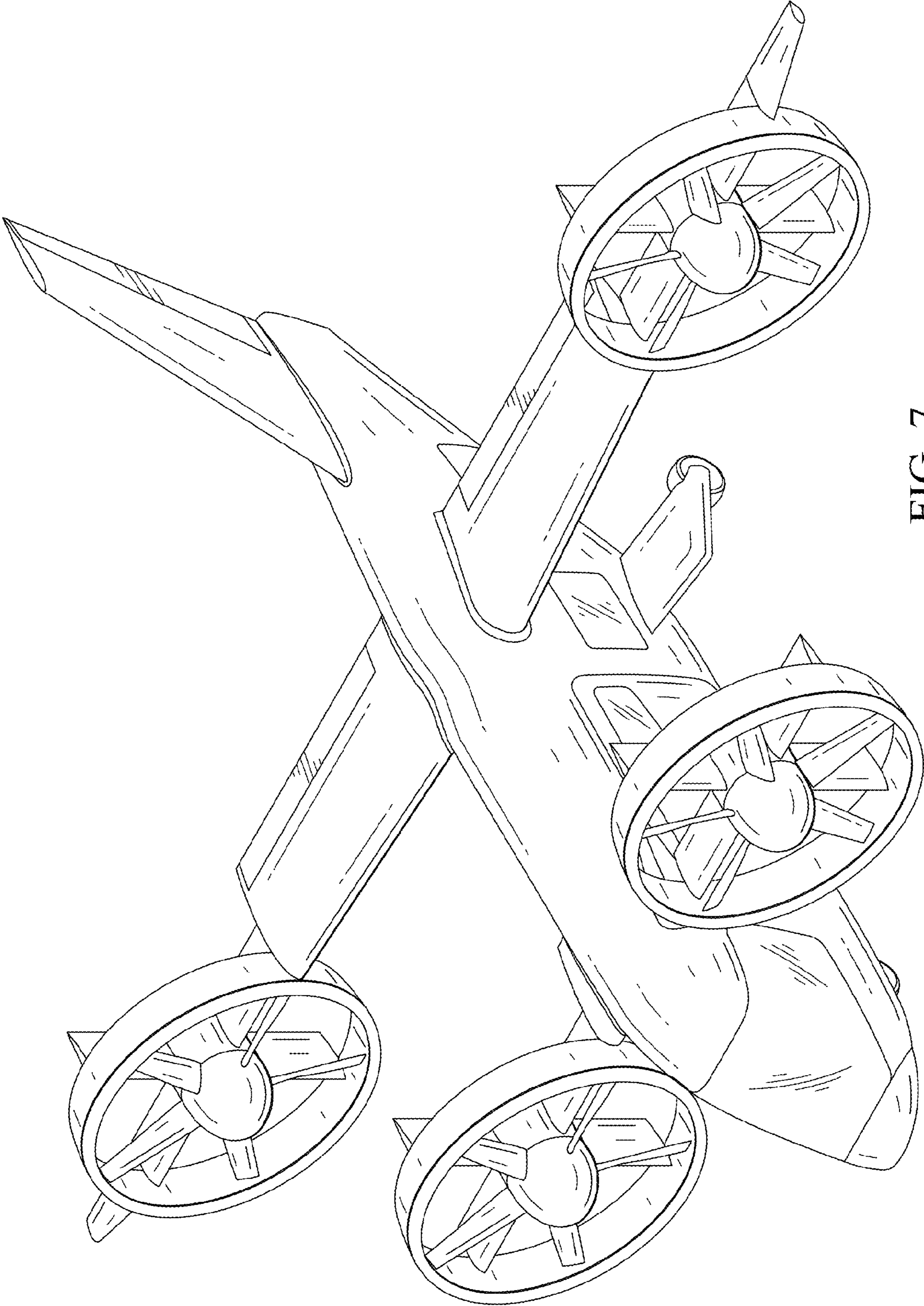

FIG. 7

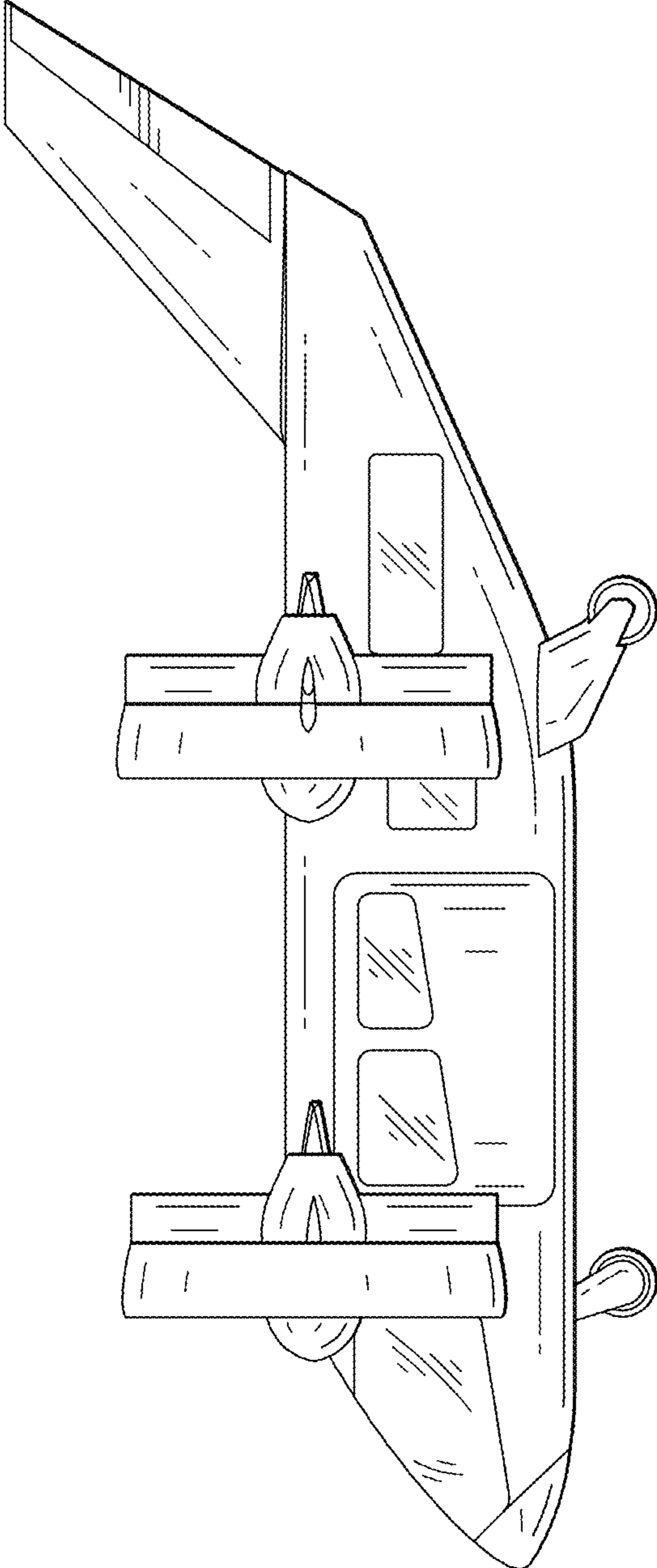

FIG. 8

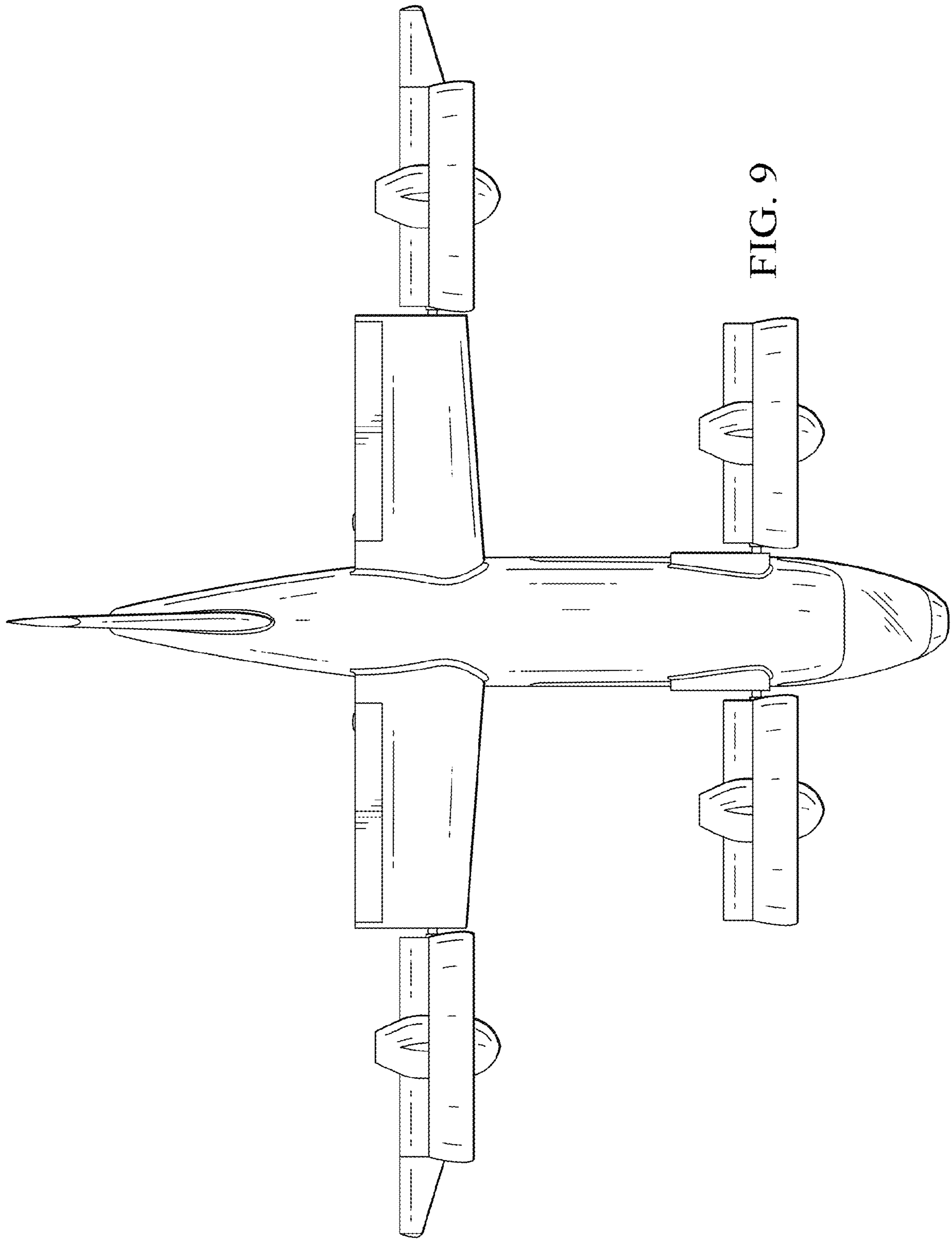

FIG. 9

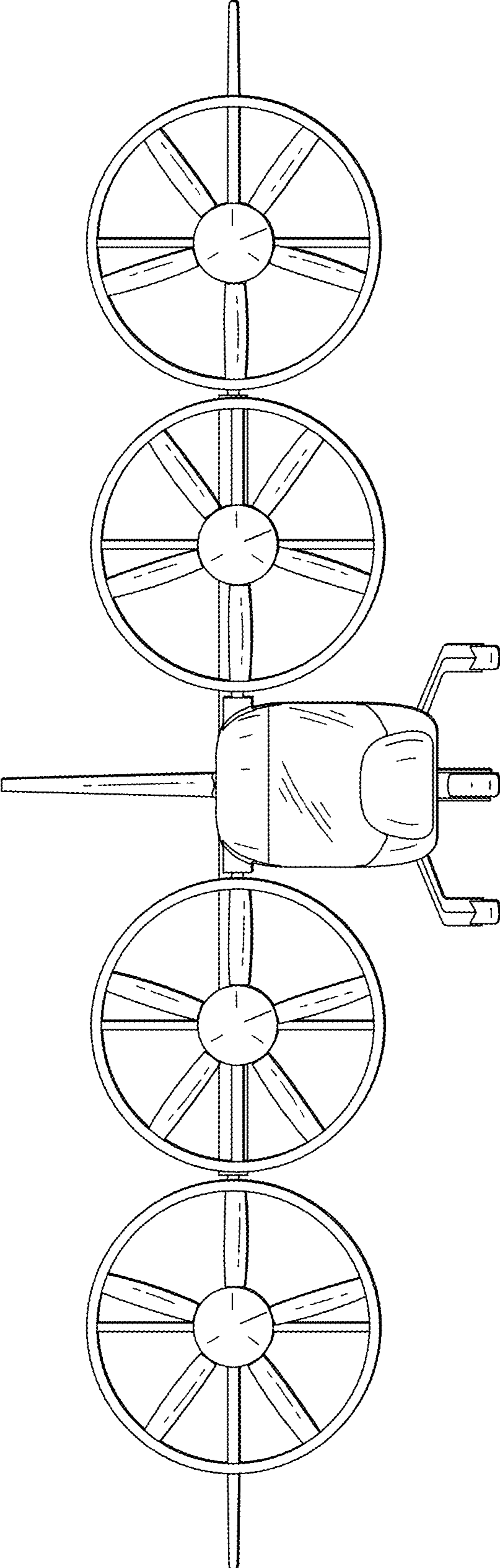

FIG. 10

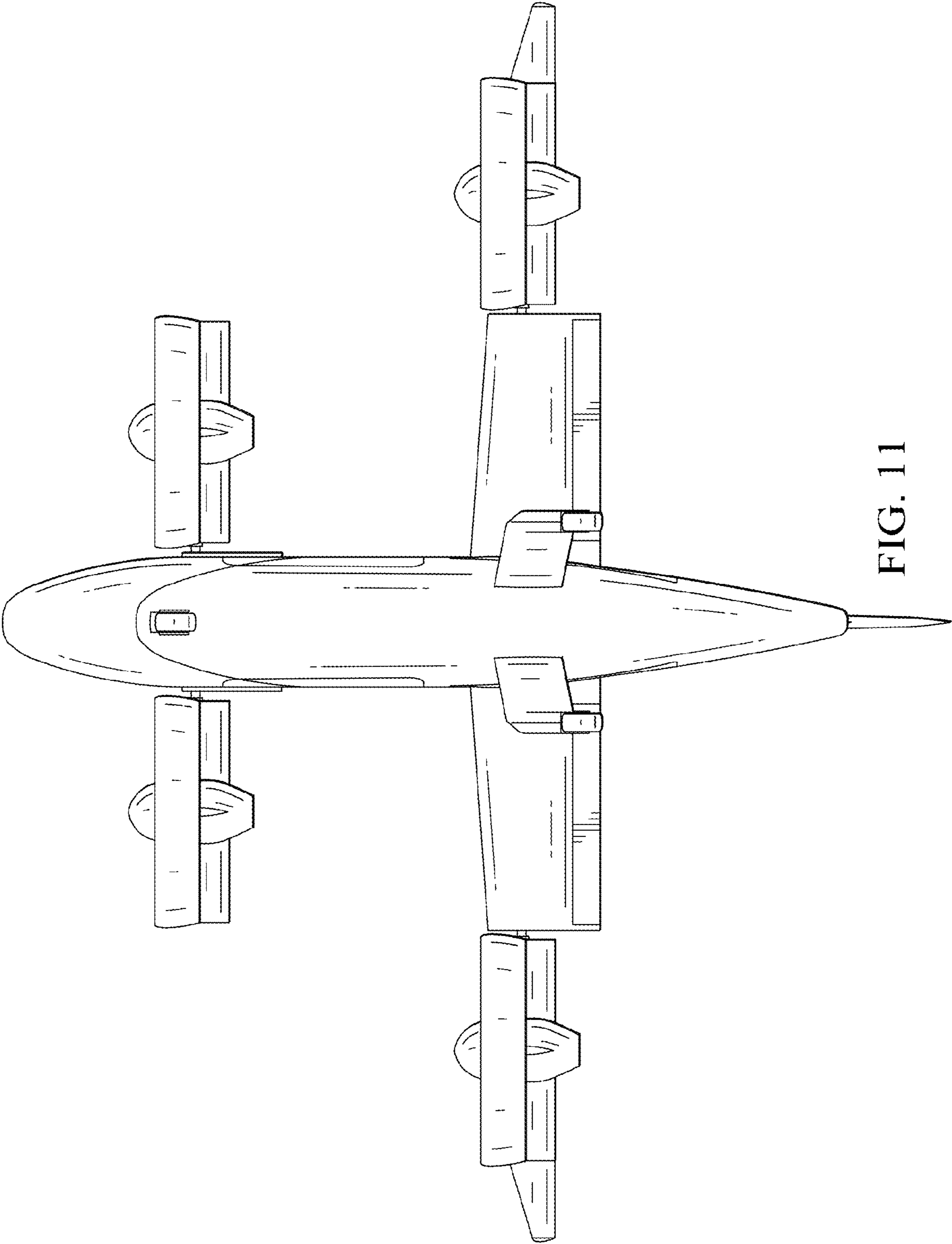

FIG. 11

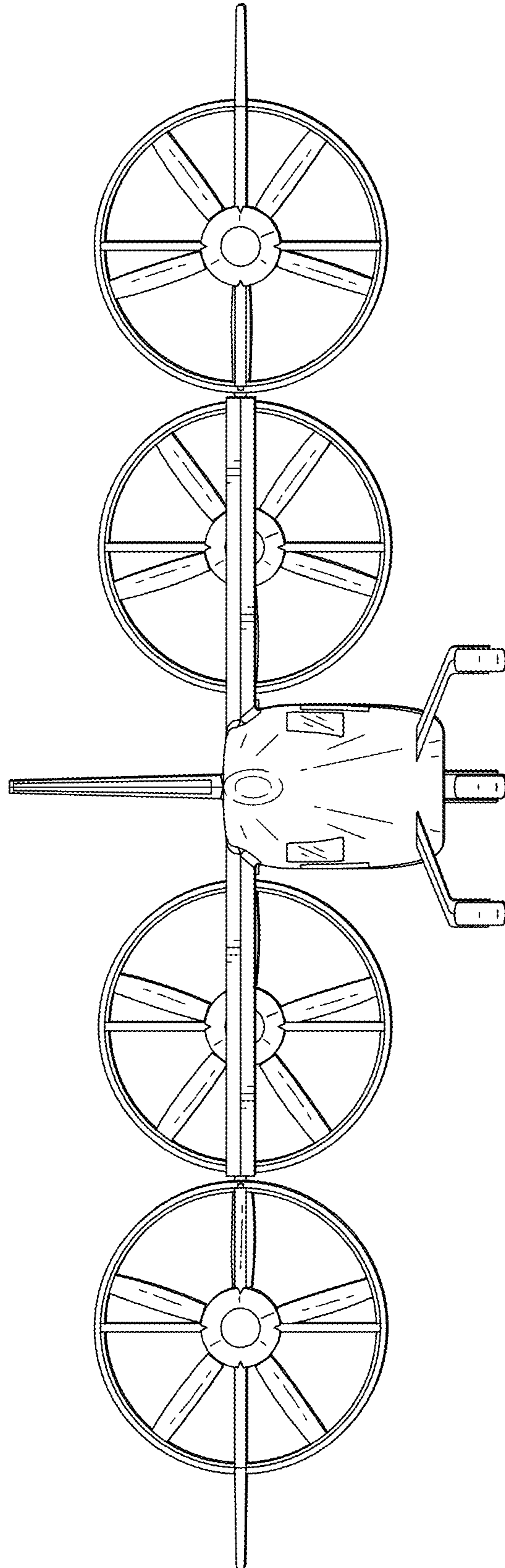

FIG. 12