



US00D920168S

(12) **United States Design Patent** (10) **Patent No.:** **US D920,168 S**
van den Adel (45) **Date of Patent:** **** May 25, 2021**

(54) **BICYCLE FRAME**

OTHER PUBLICATIONS

(71) Applicant: **TREK BICYCLE CORPORATION**,
Waterloo, WI (US)

Amazon, Flite Panic BMX Bike, posted Aug. 14, 2009, [online],
[visited Feb. 14, 2020], Internet, <URL: https://www.amazon.co.uk/Flite-Panic-Freestyle-hi-ten-freestyle/dp/B002LISET8/ref=sr_1_36?dchild=1&keywords=bike+frame&qid=1581698679&sr=8-36>
(Year: 2009).*

(72) Inventor: **Jesper van den Adel**, Madison, WI
(US)

* cited by examiner

(73) Assignee: **Trek Bicycle Corporation**, Waterloo,
WI (US)

Primary Examiner — Sheryl Lane

(**) Term: **15 Years**

Assistant Examiner — Samantha N Wood

(21) Appl. No.: **29/647,136**

(74) *Attorney, Agent, or Firm* — Bell & Manning, LLC;
Christopher Kalafut

(22) Filed: **May 10, 2018**

(51) **LOC (13) Cl.** **12-11**

(57) **CLAIM**

(52) **U.S. Cl.**

The ornamental design for a bicycle frame, as shown and
described.

USPC **D12/111**

(58) **Field of Classification Search**

USPC D12/111, 107, 114, 117, 126, 127, 159;
D21/419, 424, 427, 432

CPC . B62K 3/00; B62K 3/005; B62K 3/02; B62K
3/04; B62K 11/00; B62K 11/02; B62K
11/10; B62K 11/14; B62K 21/12; B62K
21/16; B62K 21/26; B62K 21/02; B62K
21/04; B62K 21/06; B62K 9/02; B62K
15/006; B62K 2201/04; B62K 19/02;
B62K 19/08; B62K 19/16; B62K 25/04;
B62K 25/08; B62K 25/16; B62K 25/30;
B62K 25/02; B62K 25/10

DESCRIPTION

See application file for complete search history.

FIG. 1 is a front view of a bicycle frame showing my new
design;
FIG. 2 is a back view thereof;
FIG. 3 is a right view thereof;
FIG. 4 is a left view thereof;
FIG. 5 is a top view thereof;
FIG. 6 is a bottom view thereof;
FIG. 7 is a right, rear, top perspective view thereof;
FIG. 8 is a right, front, top perspective view thereof;
FIG. 9 is a right, rear, bottom perspective view thereof;
FIG. 10 is a right, front, bottom perspective view thereof;
FIG. 11 is a left, front, top perspective view thereof;
FIG. 12 is a left, front, bottom perspective view thereof;
FIG. 13 is a left, top, rear perspective view thereof; and,
FIG. 14 is a left, bottom, rear perspective view thereof.
The broken lines are included for the purpose of showing
portions of the bicycle frame and form no part of the claimed
design.

(56) **References Cited**

U.S. PATENT DOCUMENTS

D389,787 S *	1/1998	Zeigle	D12/111
D398,266 S *	9/1998	Colegrove	D12/111
D523,380 S *	6/2006	Auger	D12/111
D588,505 S *	3/2009	Couturet	D12/111
D741,221 S *	10/2015	Haller	D12/111
9,222,568 B2 *	12/2015	Schroedl	B62M 9/02
D766,136 S *	9/2016	Jankura	D12/111
D797,610 S *	9/2017	Jankura	D12/111
10,076,929 B1 *	9/2018	Lenz	B62K 3/02

1 Claim, 13 Drawing Sheets

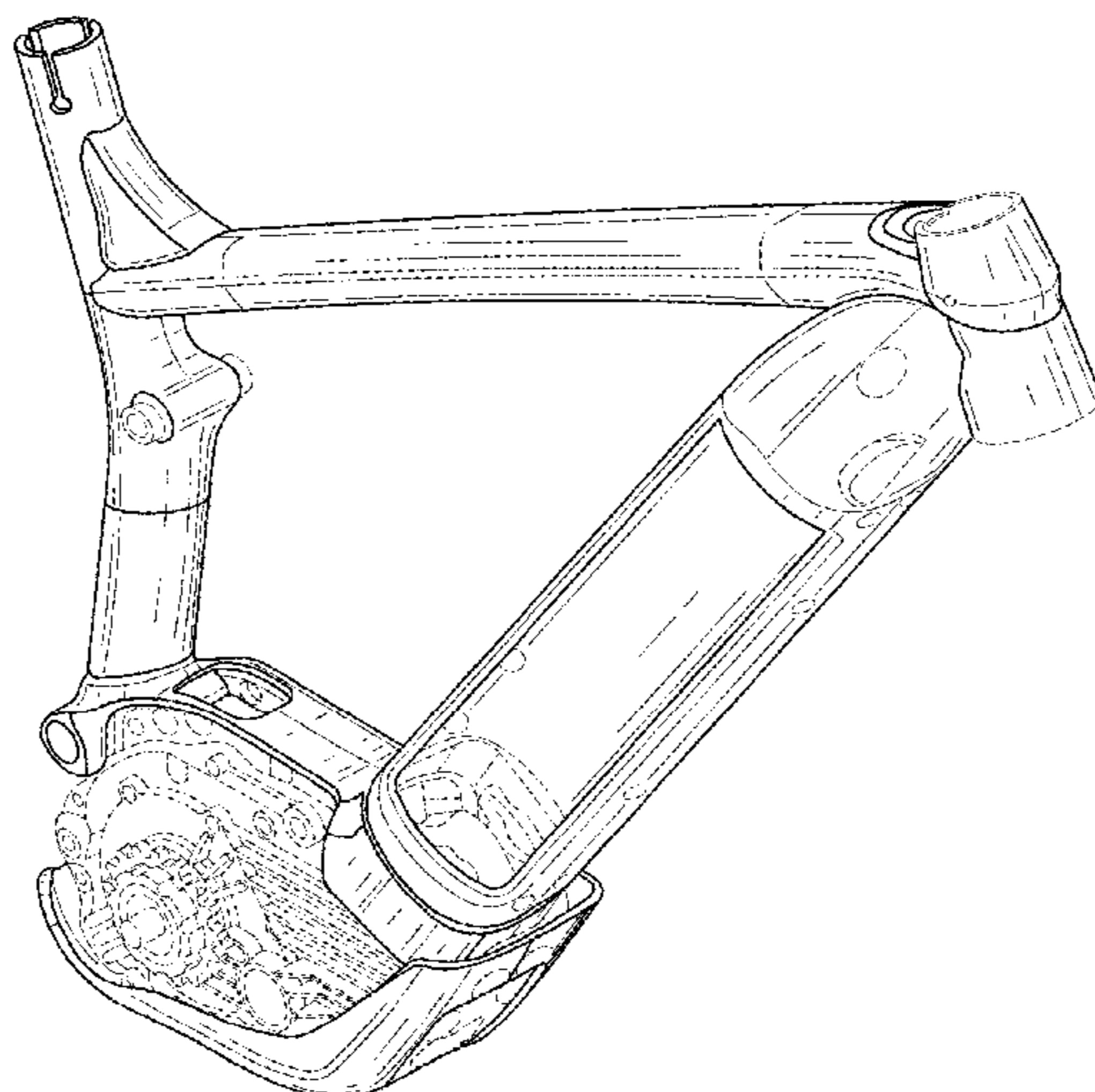

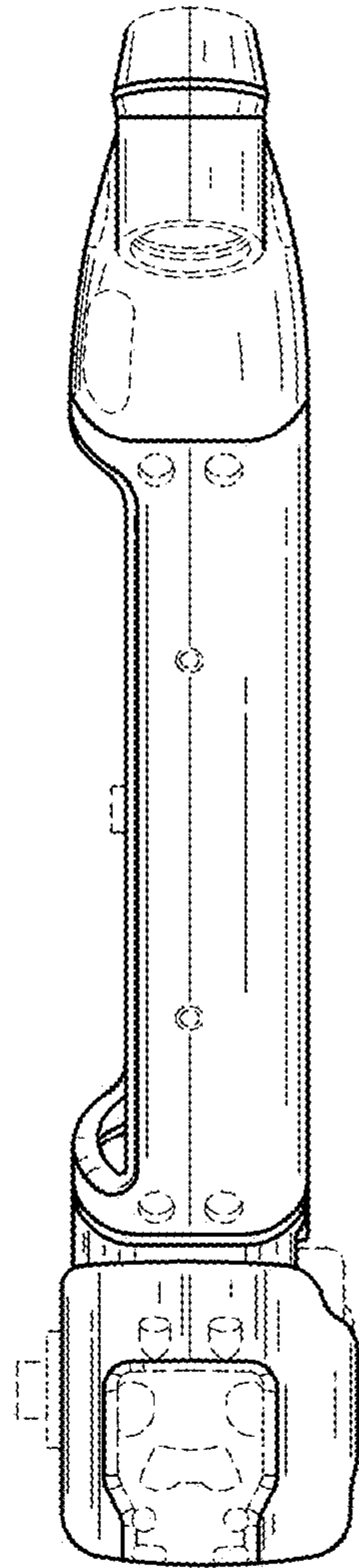

FIG. 1

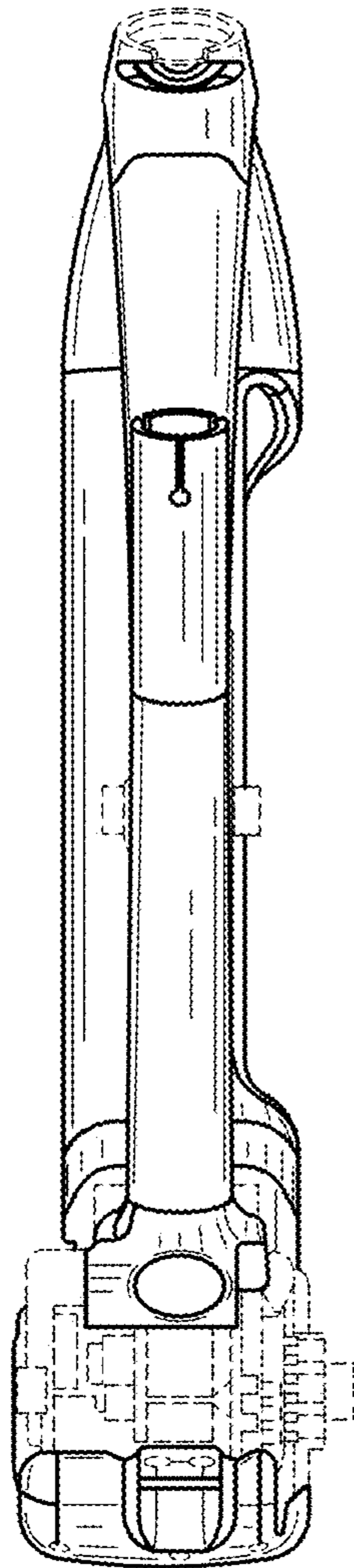

FIG. 2

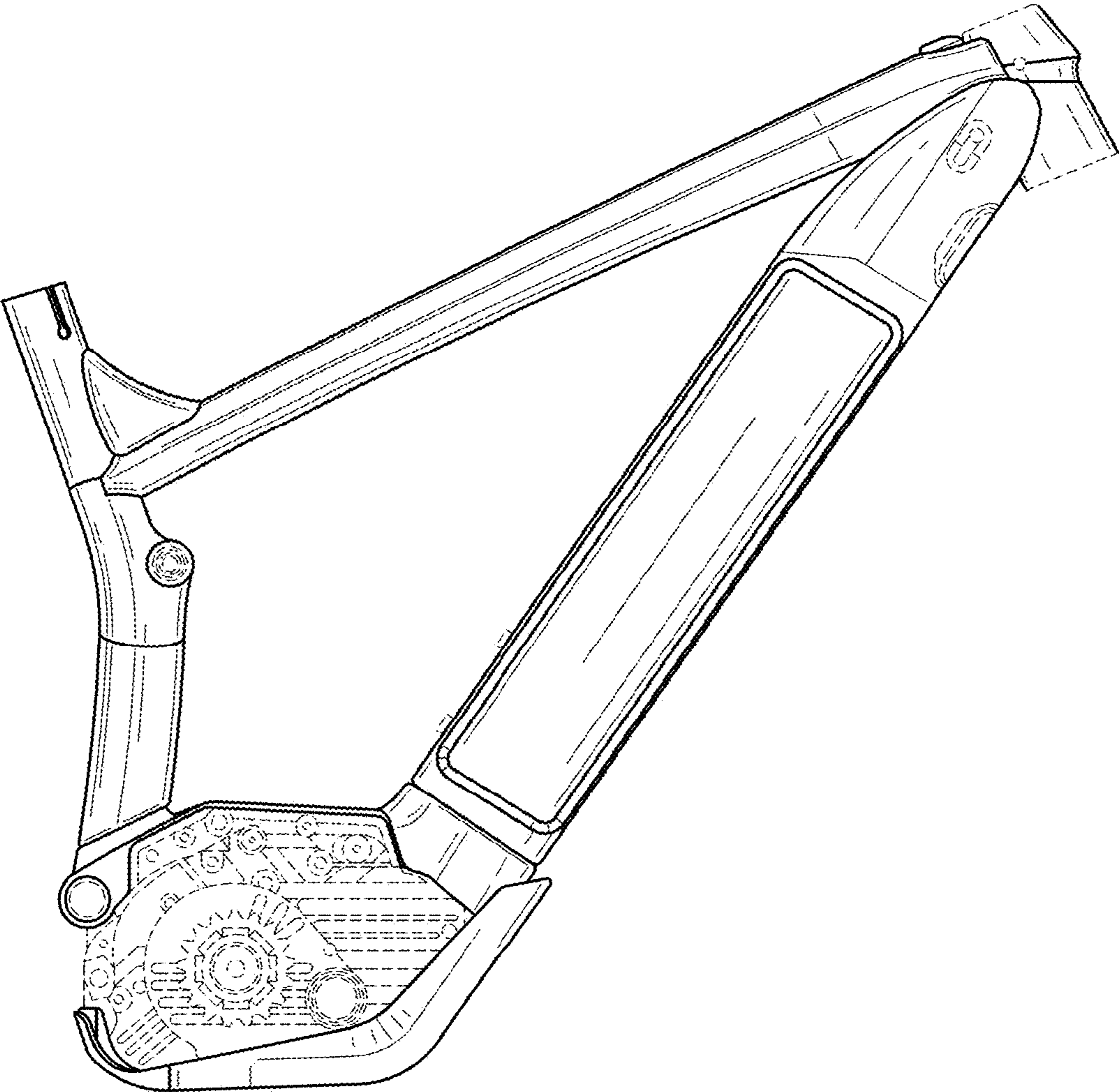

FIG. 3

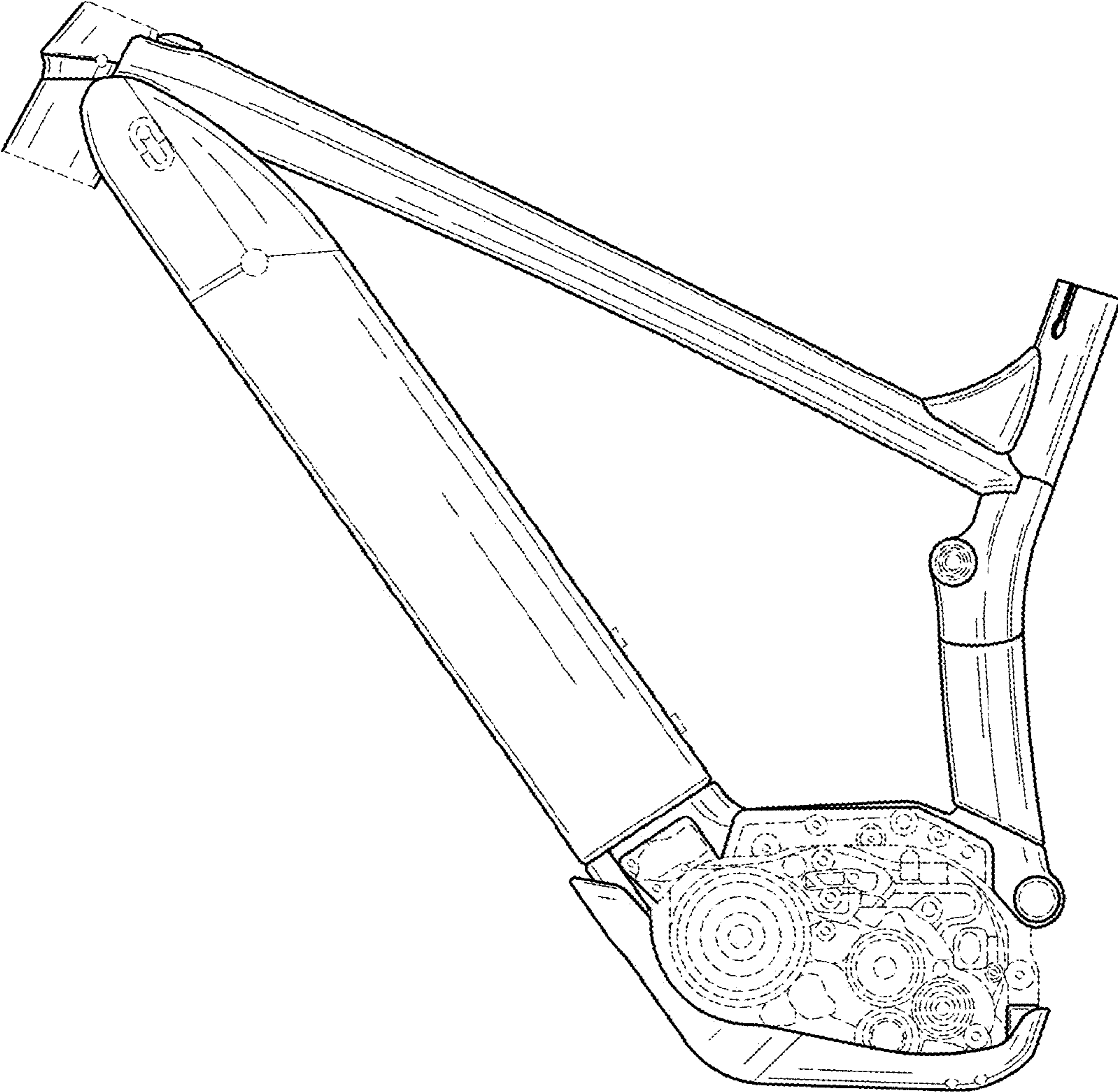

FIG. 4

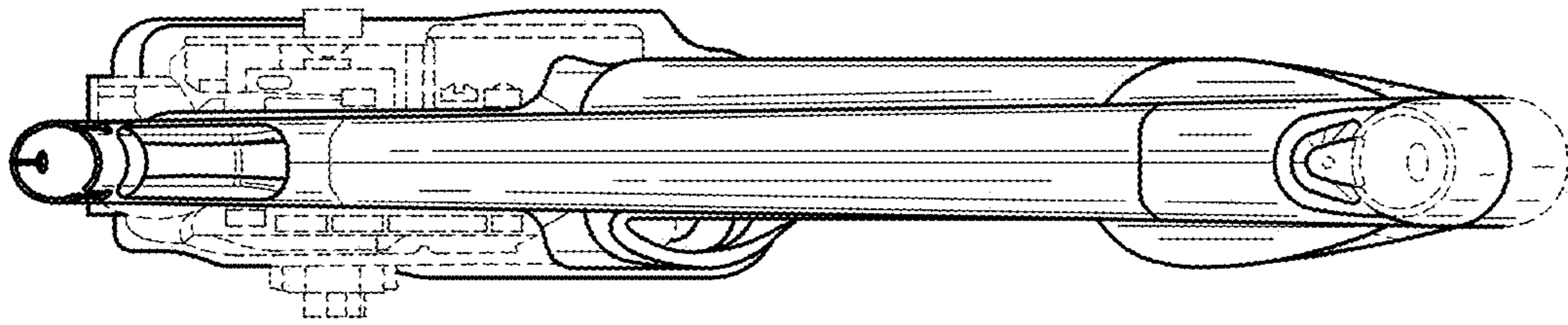

FIG. 5

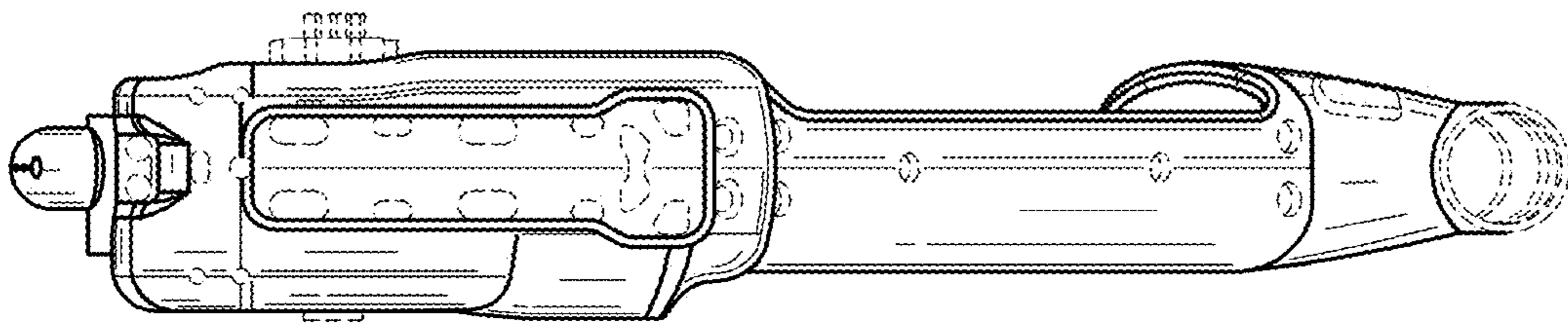

FIG. 6

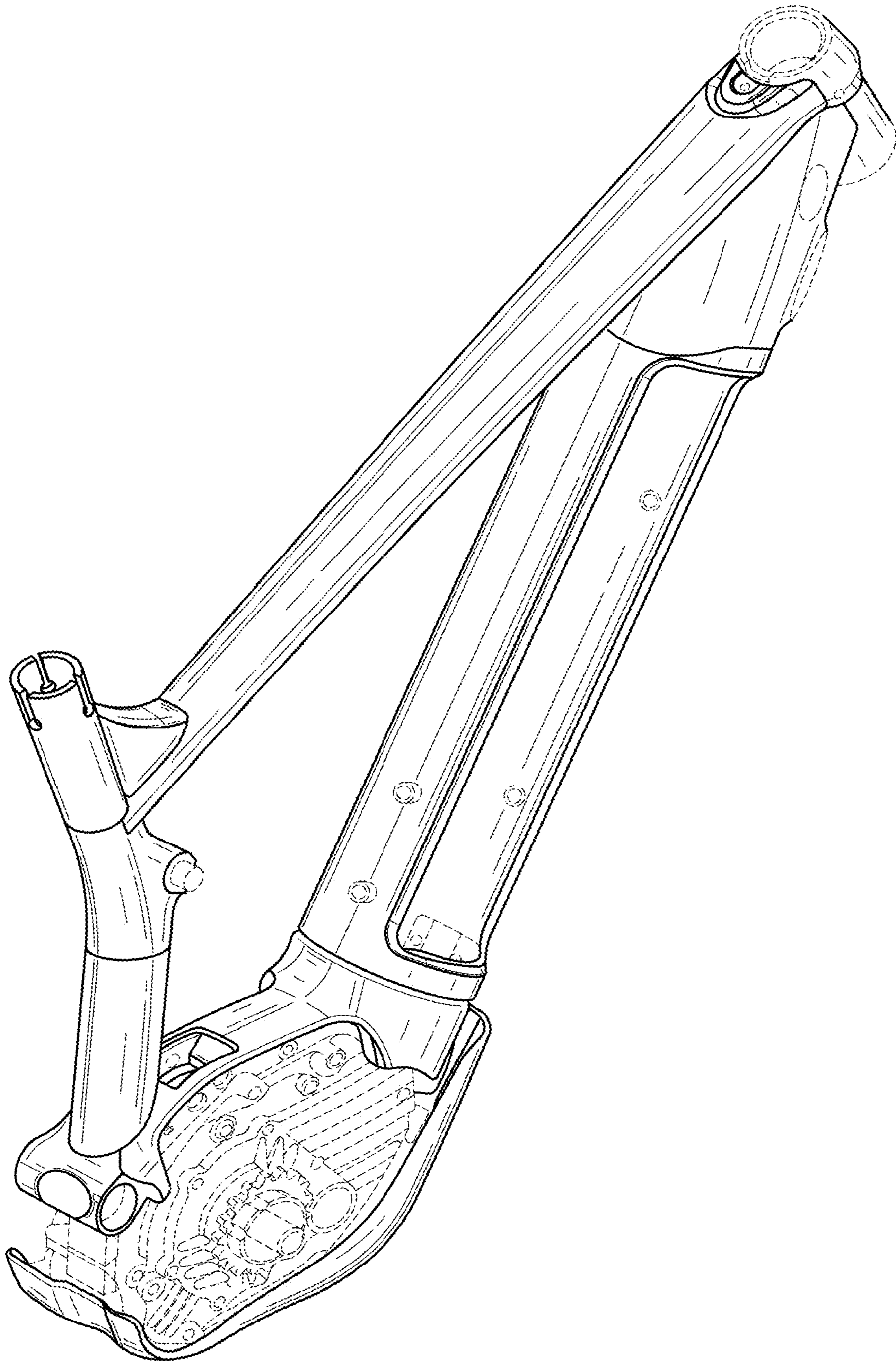

FIG. 7

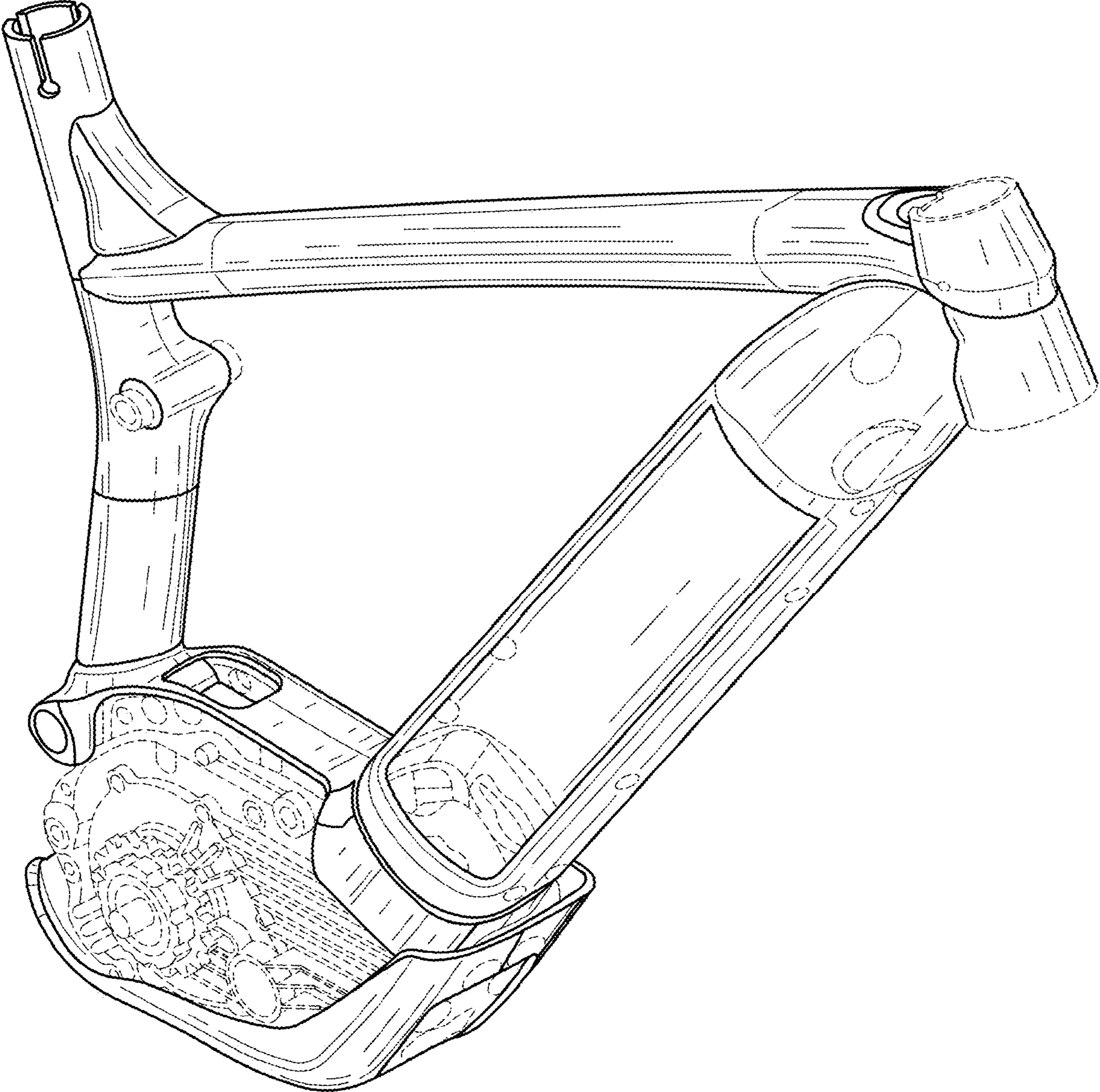

FIG. 8

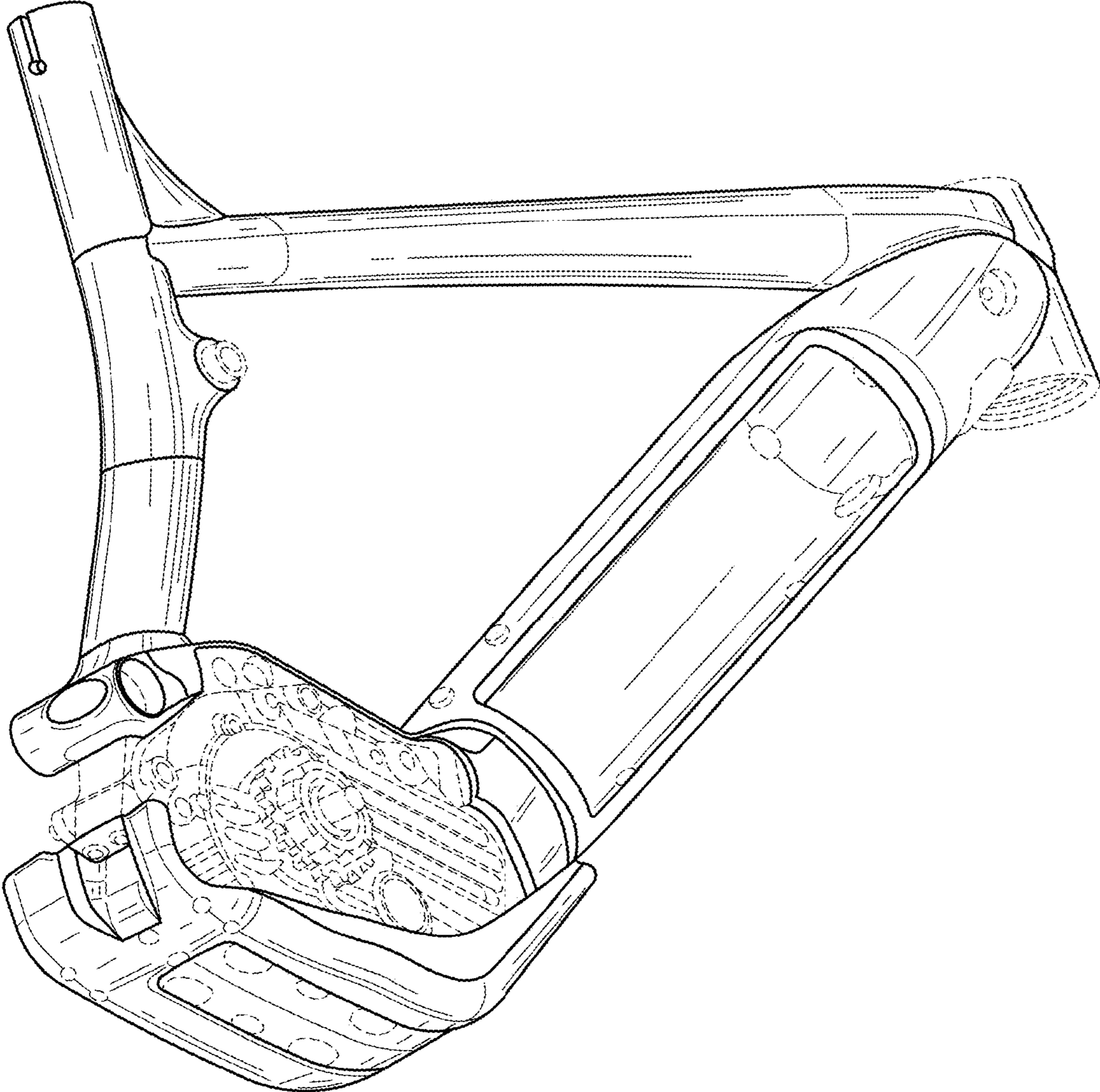

FIG. 9

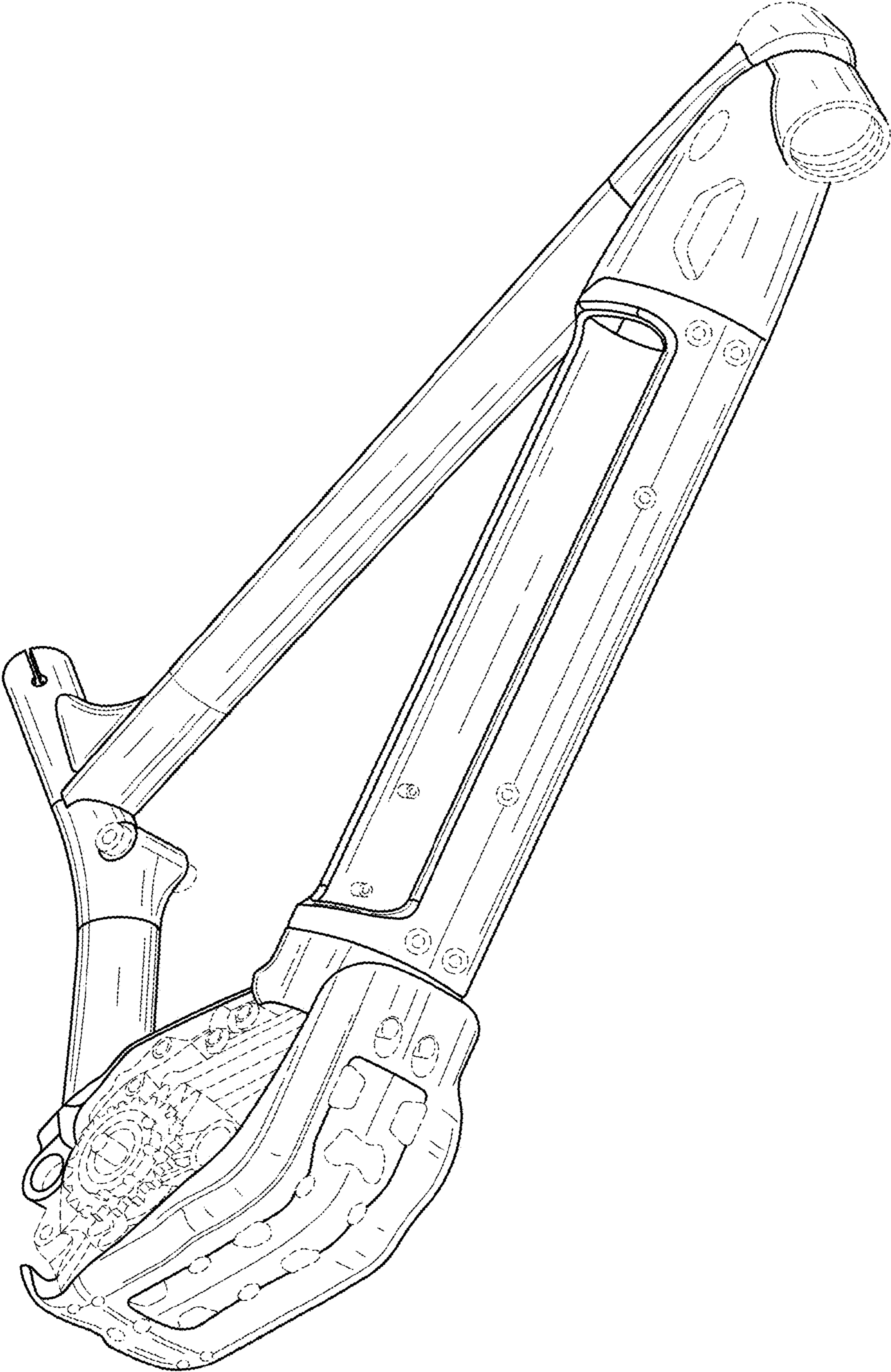

FIG. 10

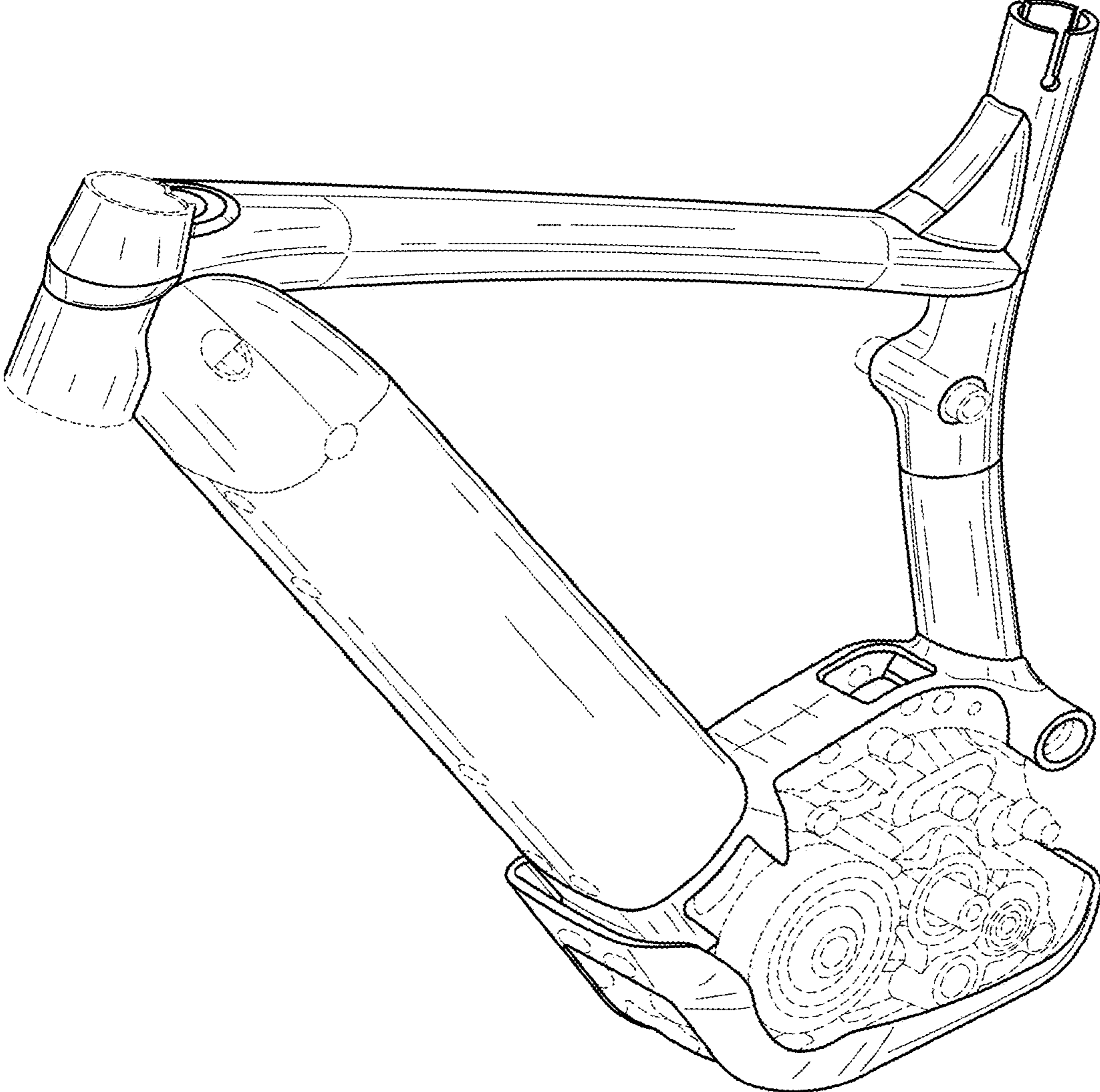

FIG. 11

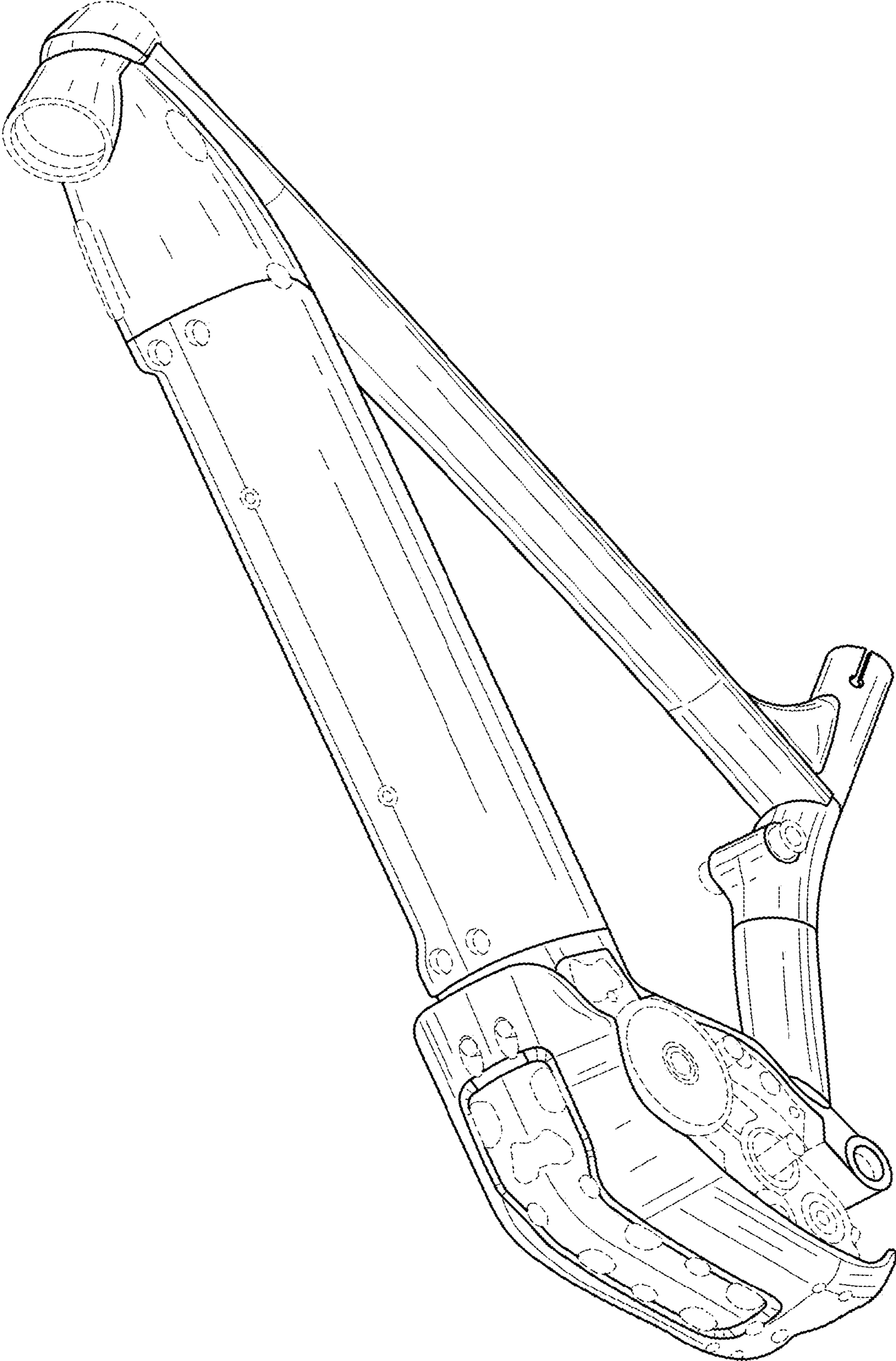

FIG. 12

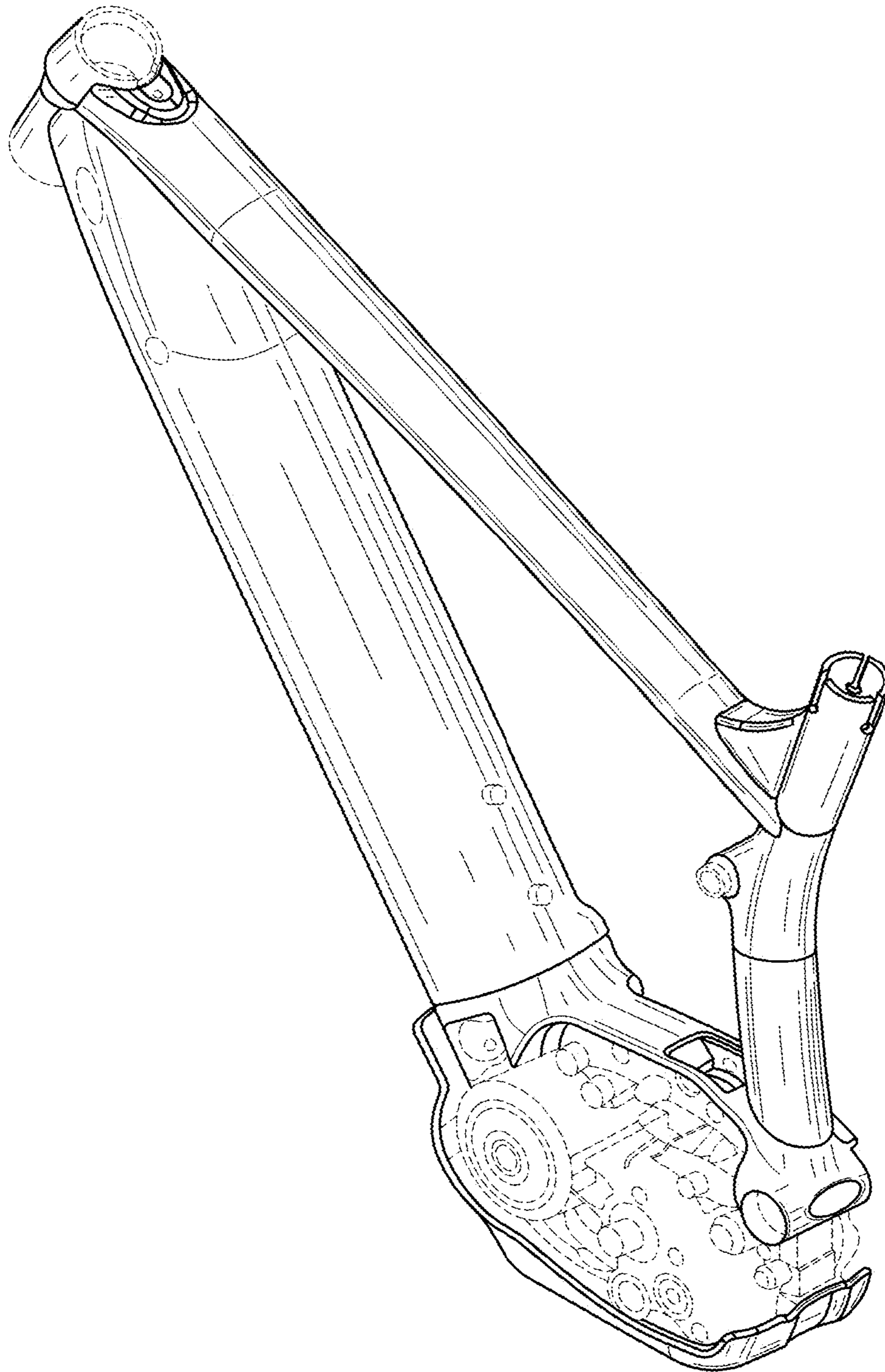

FIG. 13

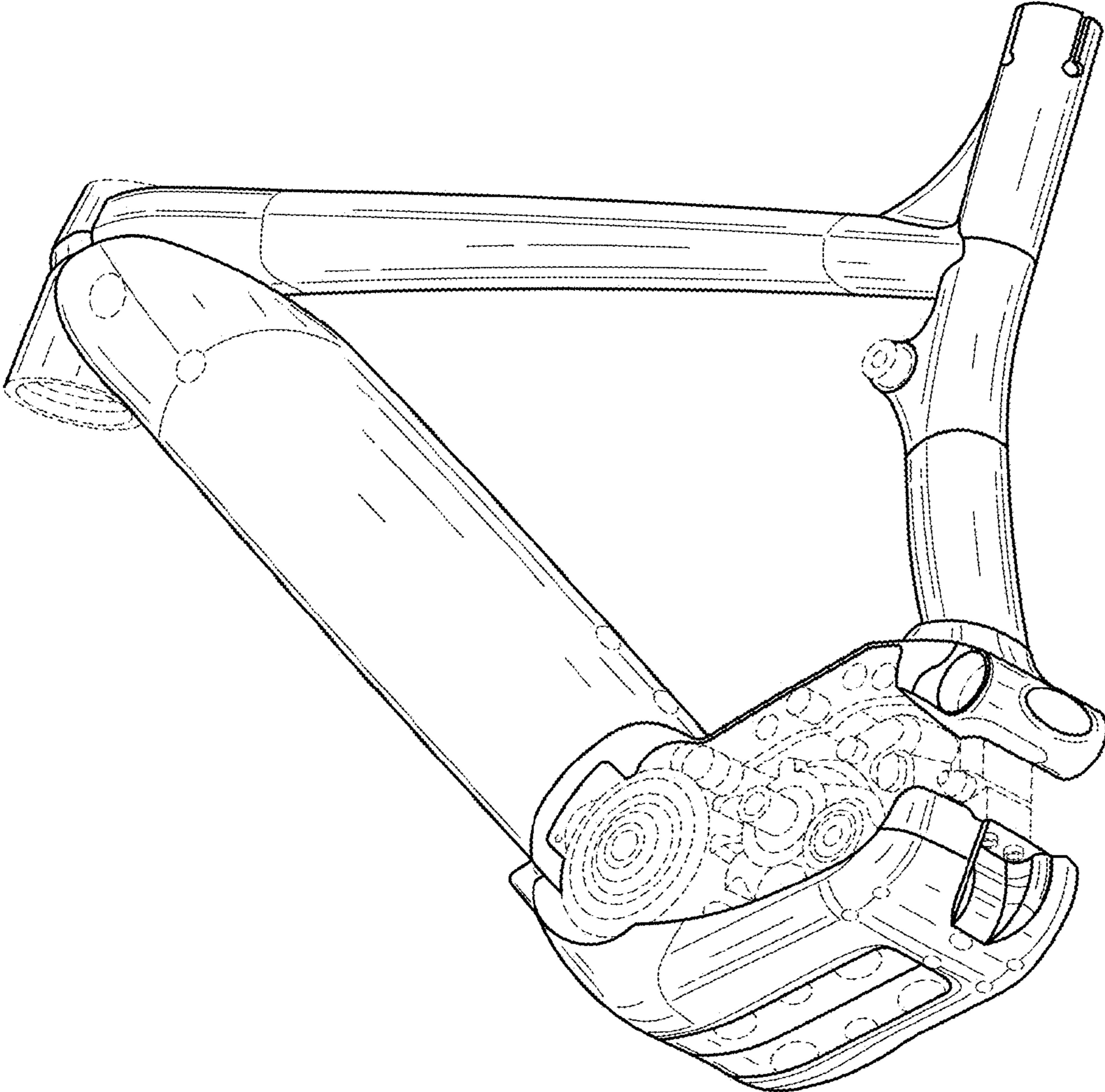

FIG. 14