



US00D919675S

(12) **United States Design Patent** (10) **Patent No.:** **US D919,675 S**
Lee et al. (45) **Date of Patent:** **** May 18, 2021**

(54) **OPERATOR'S CAB FOR A WORK VEHICLE**

(71) Applicant: **CNH Industrial America LLC**, New Holland, PA (US)

(72) Inventors: **James Hsin Yao Lee**, Bolingbrook, IL (US); **Eric Michael Jacobsthal**, Elmhurst, IL (US); **Jakub Sulikowski**, Gdansk (PL); **David Melvin Wilkie**, Turin (IT)

(73) Assignee: **CNH Industrial America LLC**, New Holland, PA (US)

(**) Term: **15 Years**

(21) Appl. No.: **29/685,661**

(22) Filed: **Mar. 29, 2019**

(51) **LOC (13) Cl.** **15-03**

(52) **U.S. Cl.**
USPC **D15/30**

(58) **Field of Classification Search**
USPC D15/10, 22-26, 28, 30; 180/89.1, 89.12, 180/89.13, 900, 9.1, 9.2, 9.62; 37/379; 414/694, 699, 722-724, 660, 685, 698, 414/719, 743
CPC E02F 3/32; E02F 3/76; E02F 3/40; E02F 3/325; E02F 3/352; E02F 3/384; E02F 3/425; E02F 3/437; E02F 3/627; E02F 3/964; E02F 9/163; E02F 9/0858; E02F 9/0875; E02F 9/2045; E02F 9/006; E02F 9/0808; E02F 9/0833; E02F 9/2004; E02F 9/207; E02F 9/2091; E02F 9/2246; E02F 9/2292

See application file for complete search history.

(56) **References Cited**

U.S. PATENT DOCUMENTS

D531,647 S * 11/2006 Stender D15/30
D541,825 S * 5/2007 Pettersson D15/30

D561,205 S * 2/2008 Pettersson D15/30
D579,028 S * 10/2008 VanDeVeer D15/30
D605,207 S * 12/2009 Menges D15/30
D660,881 S * 5/2012 Bohme D15/30
D667,851 S * 9/2012 Warr D15/30
D670,745 S * 11/2012 Warr D15/30
D671,566 S * 11/2012 Fang D15/30
D687,868 S * 8/2013 Watson D15/30
D720,370 S * 12/2014 Carter D15/30
D749,148 S * 2/2016 Darekar D15/30

(Continued)

Primary Examiner — Mark A Goodwin

(74) *Attorney, Agent, or Firm* — Rickard K. DeMille; Rebecca L. Henkel

(57) **CLAIM**

The ornamental design for an operator's cab for a work vehicle, as shown and described.

DESCRIPTION

FIG. 1 is a front perspective view of an operator's cab for a work vehicle showing our new design.
FIG. 2 is a front view thereof.
FIG. 3 is a rear view thereof.
FIG. 4 is a first side view thereof.
FIG. 5 is a second side view thereof.
FIG. 6 is a top view thereof.
FIG. 7 is a bottom view thereof; and,
FIG. 8 is a rear perspective view thereof, particularly illustrating an environmental view of the operator's cab for a work vehicle, such as a wheel loader.
The broken lines contained within the figures, including, but, not limited to, any dash-dot broken lines and/or dash-dash broken lines, represent portions of the operator's cab for a work vehicle that form no part of the claimed design. Additionally, contour lines and/or surface shading are illustrated simply for purposes of highlighting the solid-rendering, and, thus, form no part of the claimed design.

1 Claim, 8 Drawing Sheets

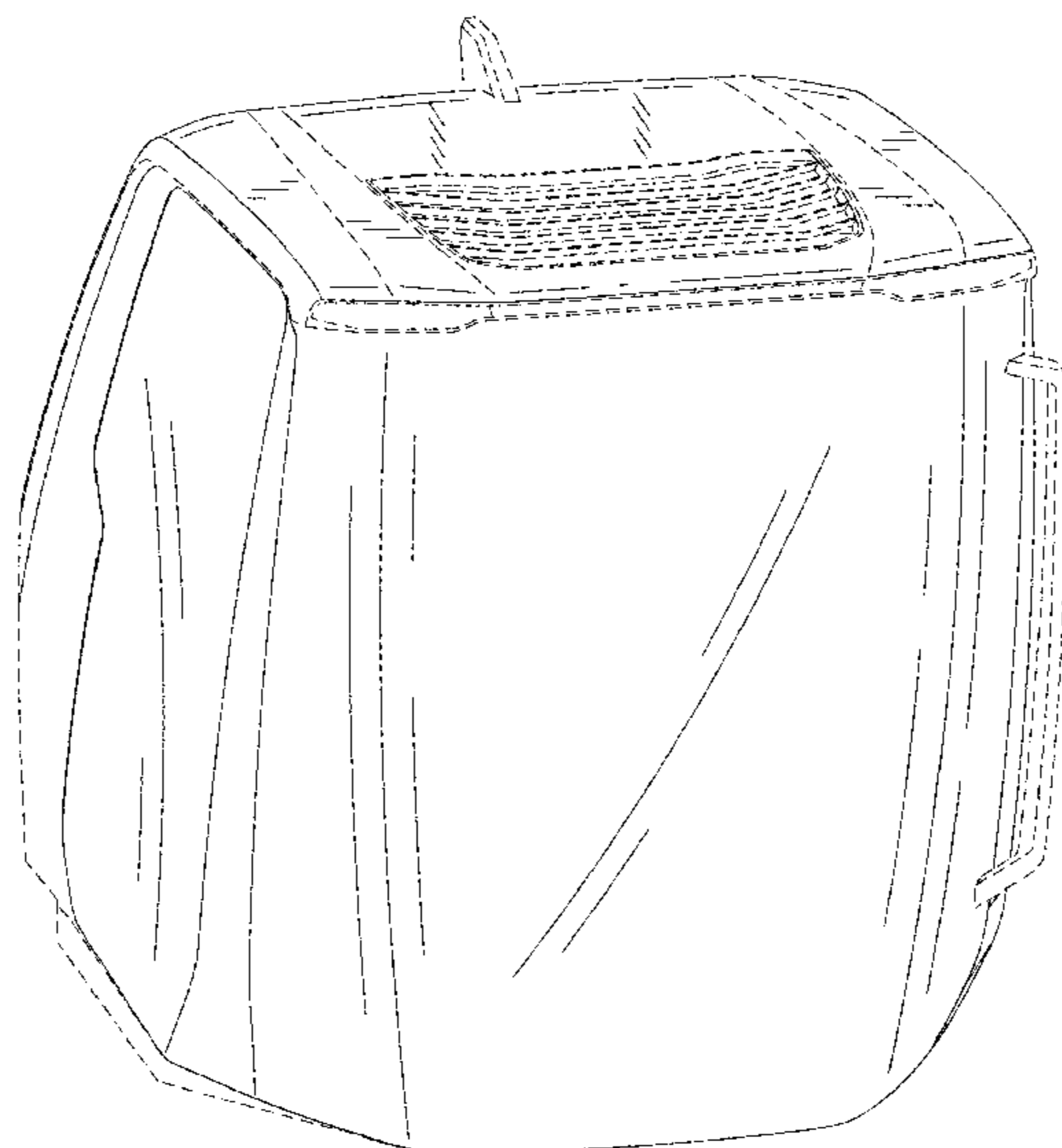

(56)

References Cited

U.S. PATENT DOCUMENTS

D749,149 S	*	2/2016	McAdam	D15/30
D871,462 S	*	12/2019	Svitek	D15/30
D874,524 S	*	2/2020	Iwata	D15/30
D877,209 S	*	3/2020	Winkel	D15/30

* cited by examiner

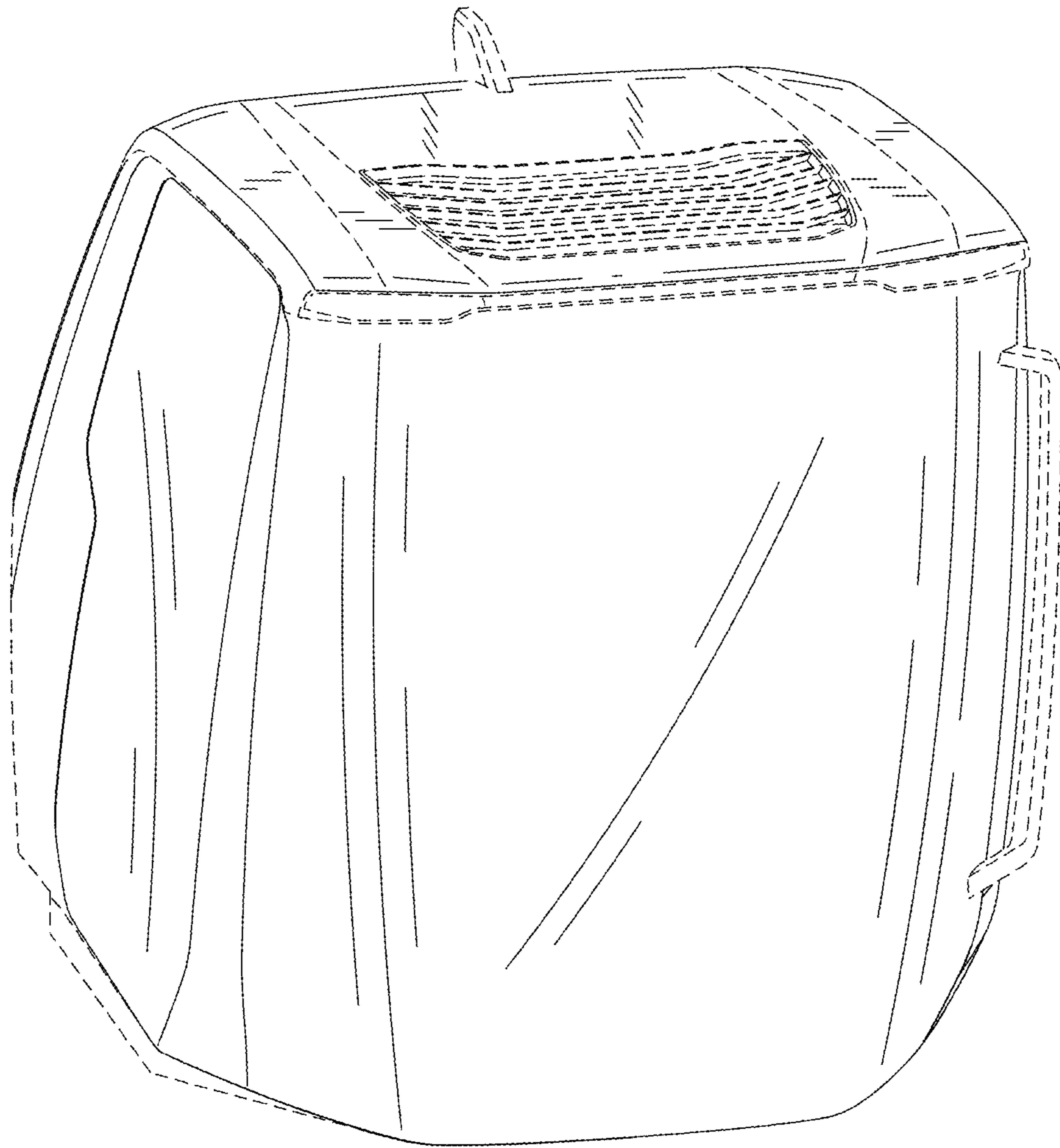

FIG. 1

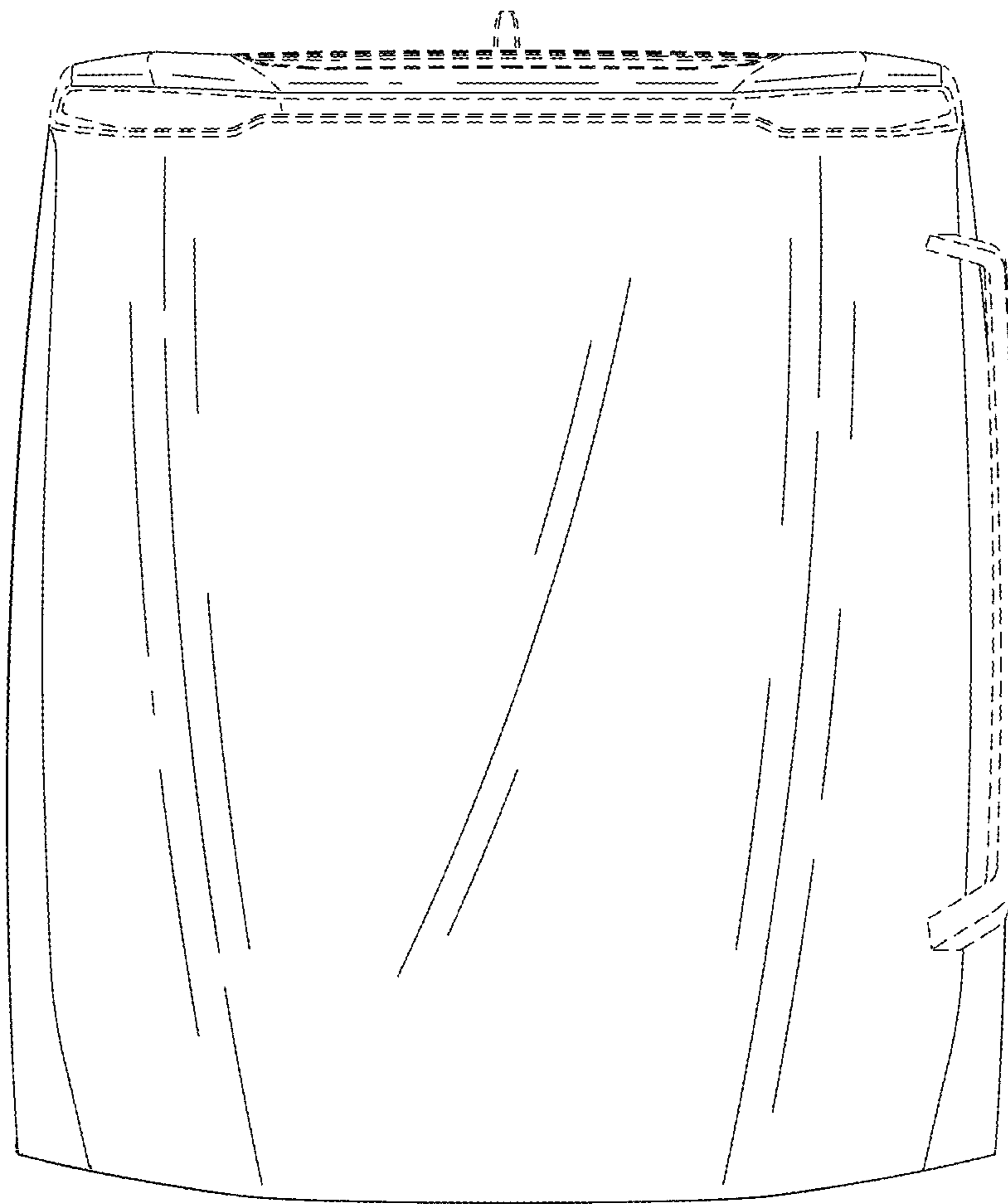

FIG. 2

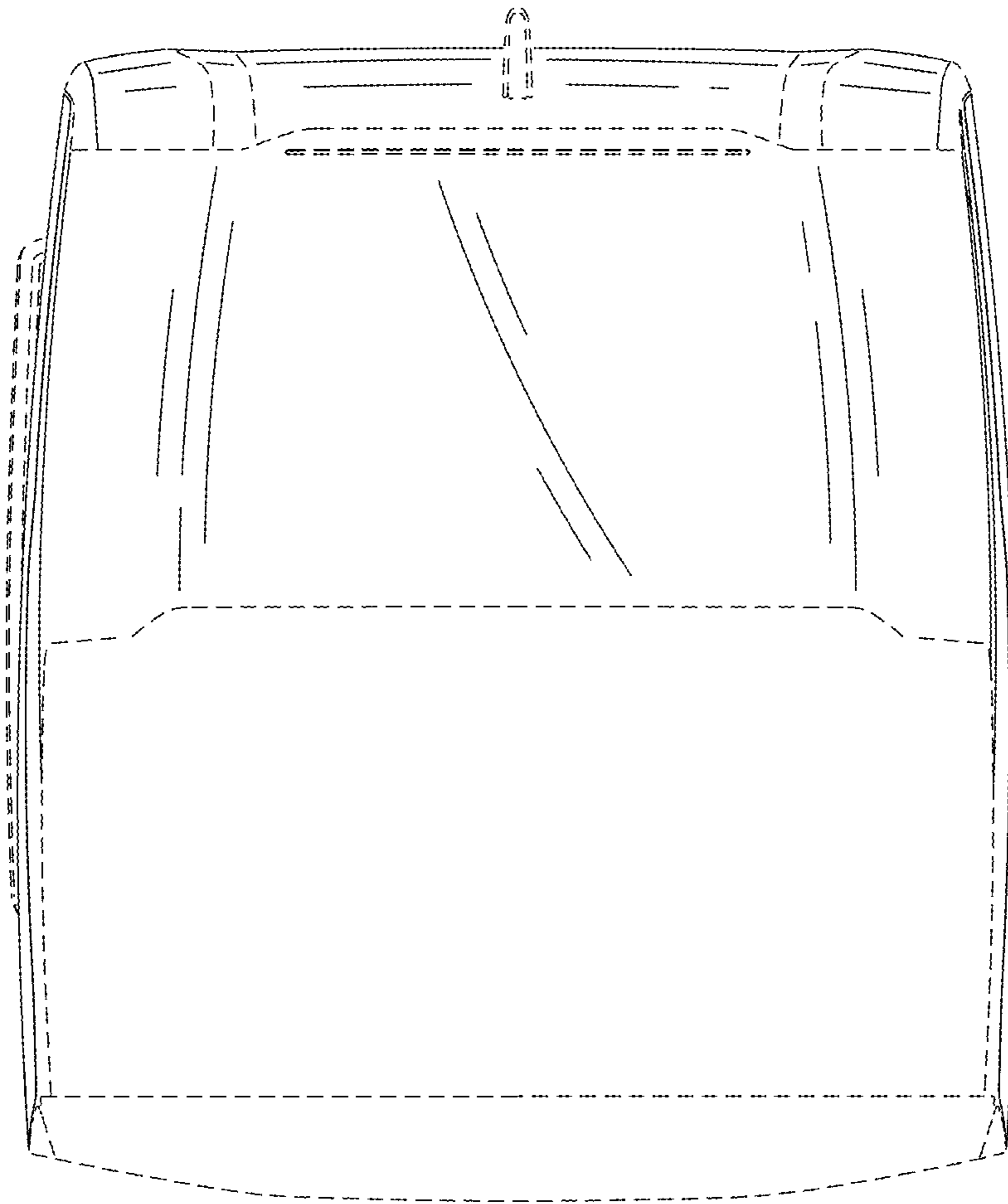

FIG. 3

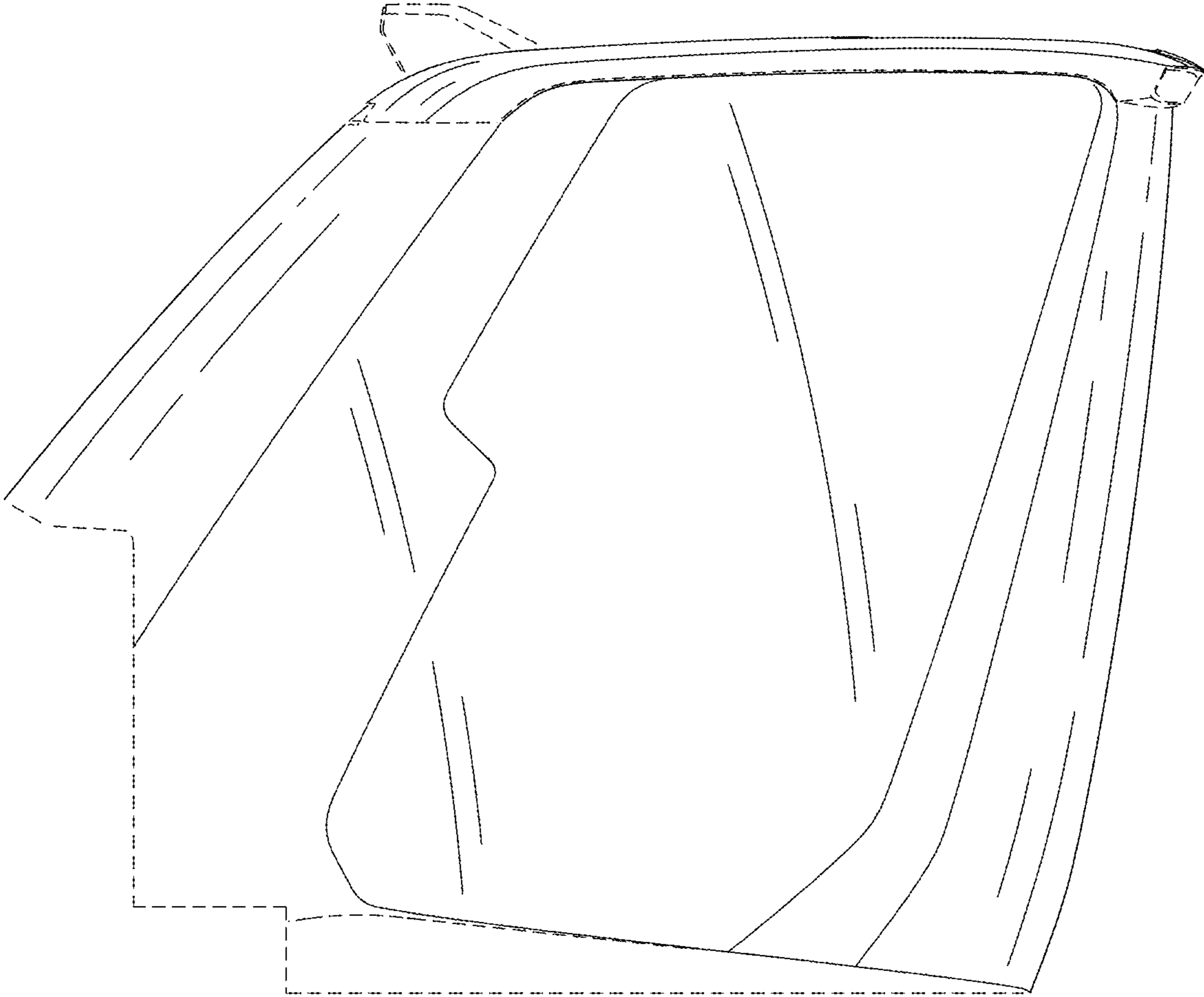

FIG. 4

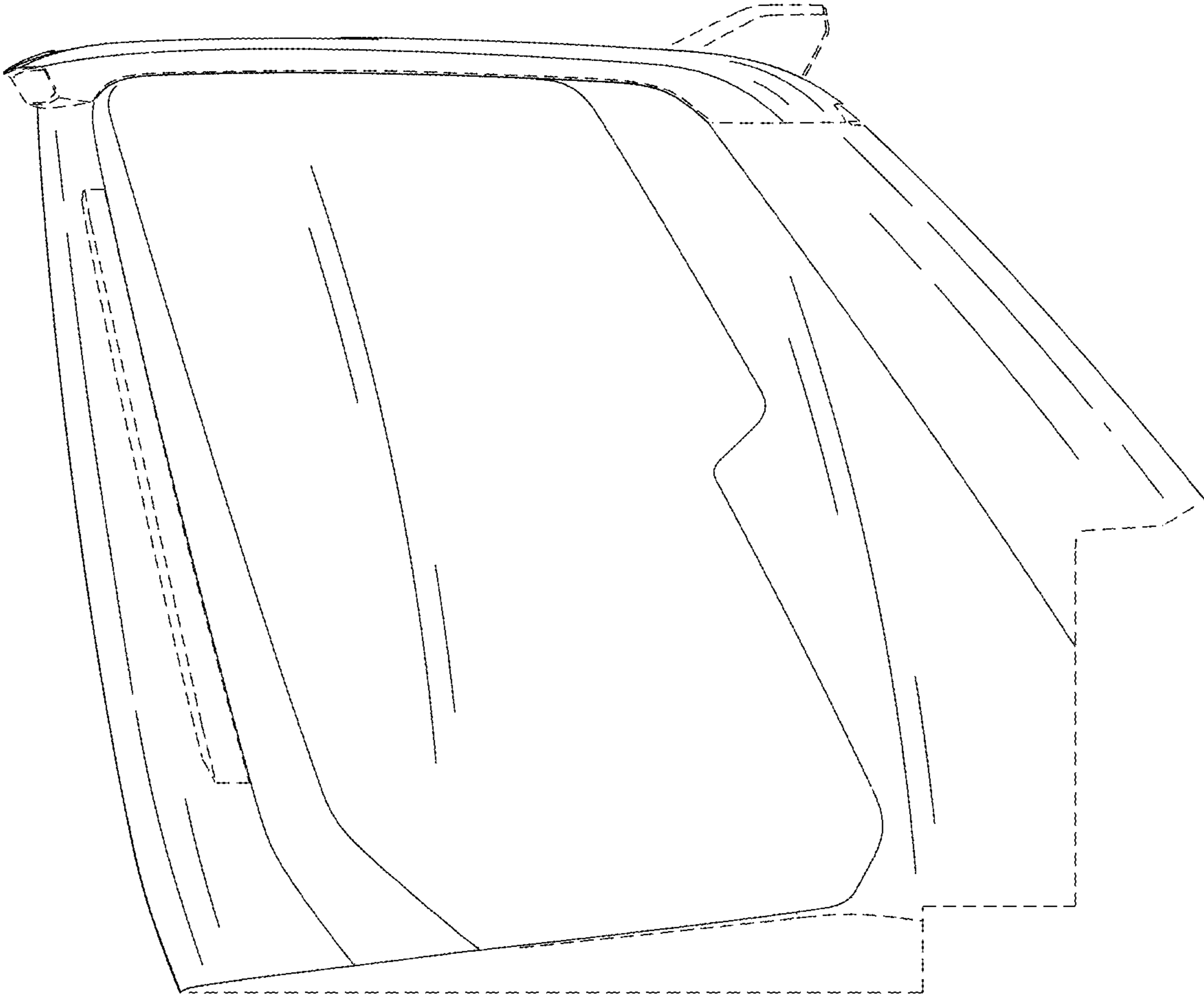

FIG. 5

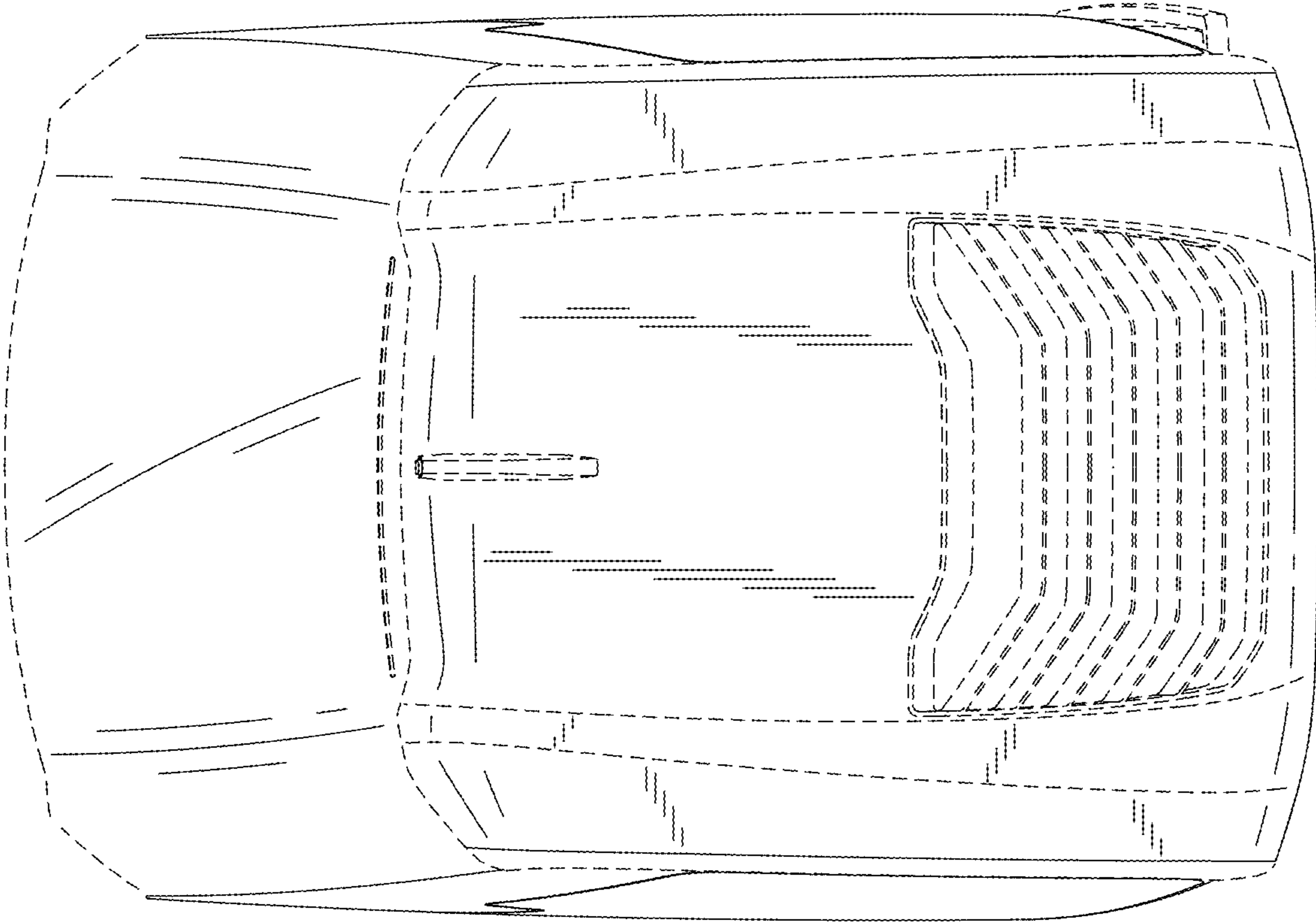

FIG. 6

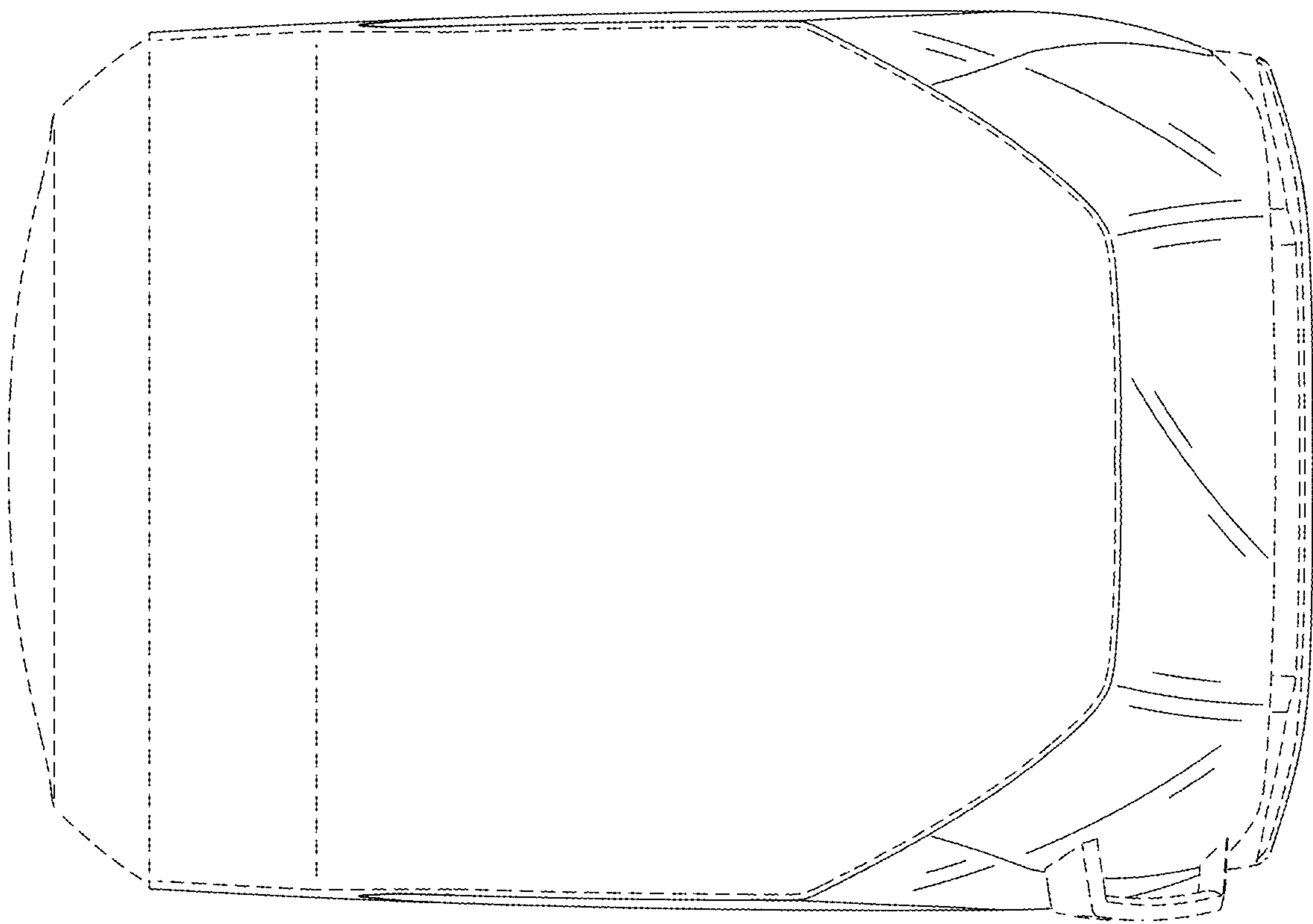

FIG. 7

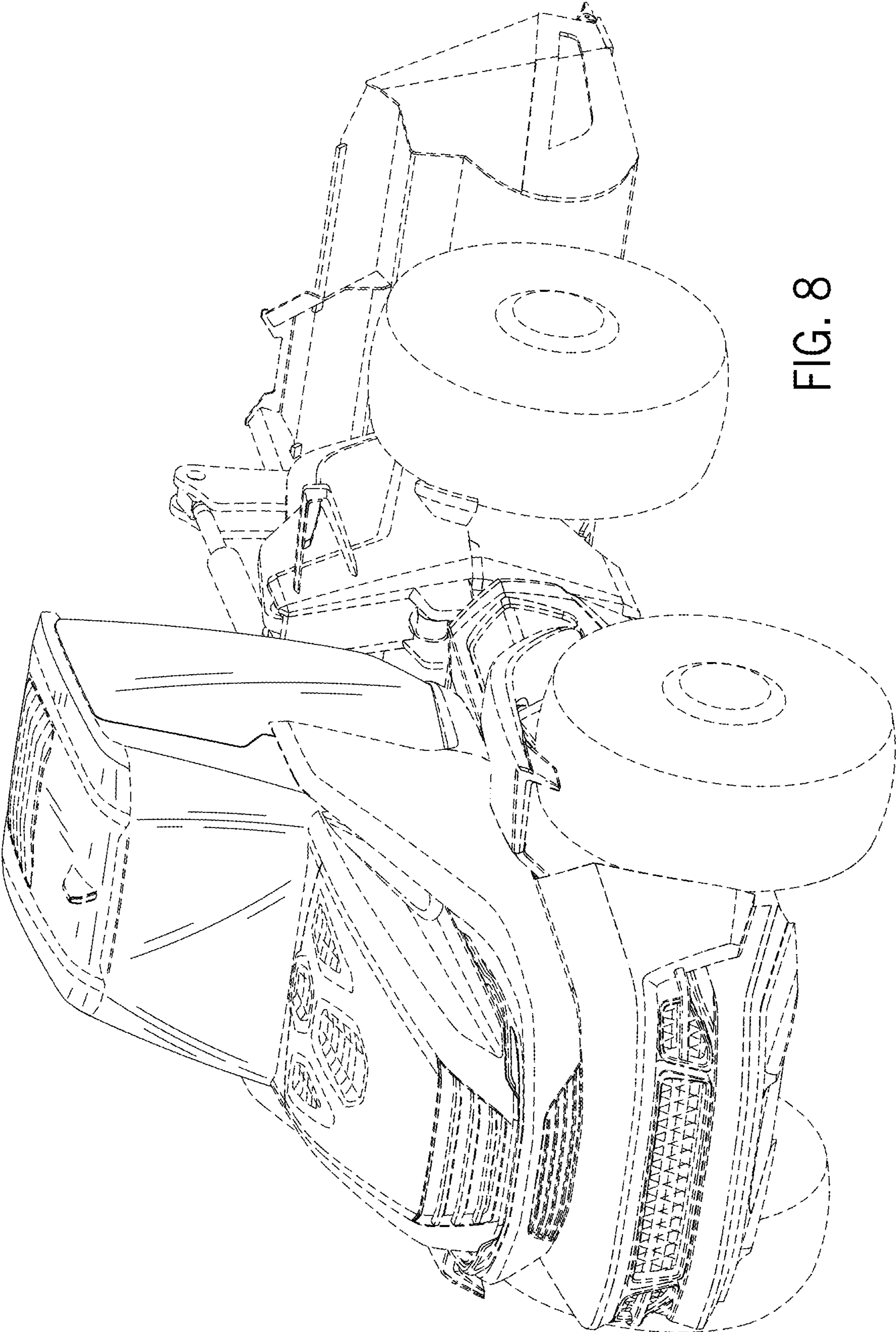

FIG. 8