



US00D919547S

(12) **United States Design Patent**
Carpenter et al.

(10) **Patent No.:** **US D919,547 S**

(45) **Date of Patent:** **** May 18, 2021**

(54) **AIRCRAFT FUSELAGE**

(71) Applicant: **Bell Textron Inc.**, Fort Worth, TX (US)

(72) Inventors: **Joseph Richard Carpenter**, Kennedale, TX (US); **Timothy Carr**, Fort Worth, TX (US); **Matthew E. Louis**, Fort Worth, TX (US); **Steve Michael Loveland**, Fort Worth, TX (US)

(73) Assignee: **BELL TEXTRON INC.**, Fort Worth, TX (US)

(**) Term: **15 Years**

(21) Appl. No.: **29/719,438**

(22) Filed: **Jan. 3, 2020**

(51) **LOC (13) Cl.** **12-07**

(52) **U.S. Cl.**
USPC **D12/319**

(58) **Field of Classification Search**
USPC D12/1, 2, 3, 4, 16.1, 174, 319-345;
D21/436-455; D13/109
CPC B64C 29/0033; B64C 2201/021; B64C
29/02; B64C 2201/088; B64C 2201/104;
B64C 2201/141

See application file for complete search history.

(56) **References Cited**

U.S. PATENT DOCUMENTS

10,562,620	B2 *	2/2020	Kroo	B64C 29/0033
D887,948	S *	6/2020	Loveland	D12/328
2012/0043413	A1 *	2/2012	Smith	B64C 29/0033
					244/12.4
2012/0234968	A1 *	9/2012	Smith	B64D 17/64
					244/12.3
2018/0057157	A1 *	3/2018	Groninga	B64C 27/82
2019/0291860	A1 *	9/2019	Morgan	B64D 35/04

2020/0223530	A1 *	7/2020	Carpenter, Jr.	B64C 11/46
2020/0239134	A1 *	7/2020	Robertson	B64C 29/0033
2020/0255135	A1 *	8/2020	Hong	B64C 39/08
2020/0262553	A1 *	8/2020	Gomez	B64C 39/08

OTHER PUBLICATIONS

Bell Reveals the City of the Future at CES 2020 (article) [Jan. 6, 2020] found online [Nov. 30, 2020]—<https://news.bellflight.com/en-US/184550-bell-reveals-the-city-of-the-future-at-ces-2020>.*

* cited by examiner

Primary Examiner — John A Voytek

(74) *Attorney, Agent, or Firm* — Patent Capital Group

(57) **CLAIM**

The ornamental design for an aircraft fuselage, substantially as shown and described.

DESCRIPTION

FIG. 1 is a perspective view of our new design for an aircraft fuselage;

FIG. 2 is a side view in elevation of the aircraft fuselage as shown in FIG. 1;

FIG. 3 is a top plan view of the aircraft fuselage as shown in FIG. 1;

FIG. 4 is a front elevational view of the aircraft fuselage as shown in FIG. 1;

FIG. 5 is a bottom plan view of the aircraft fuselage as shown in FIG. 1; and,

FIG. 6 is a rear elevational view of the aircraft fuselage as shown in FIG. 1.

The broken lines in the drawings are for the purpose of illustrating environmental structure and form no part of the claimed design.

1 Claim, 6 Drawing Sheets

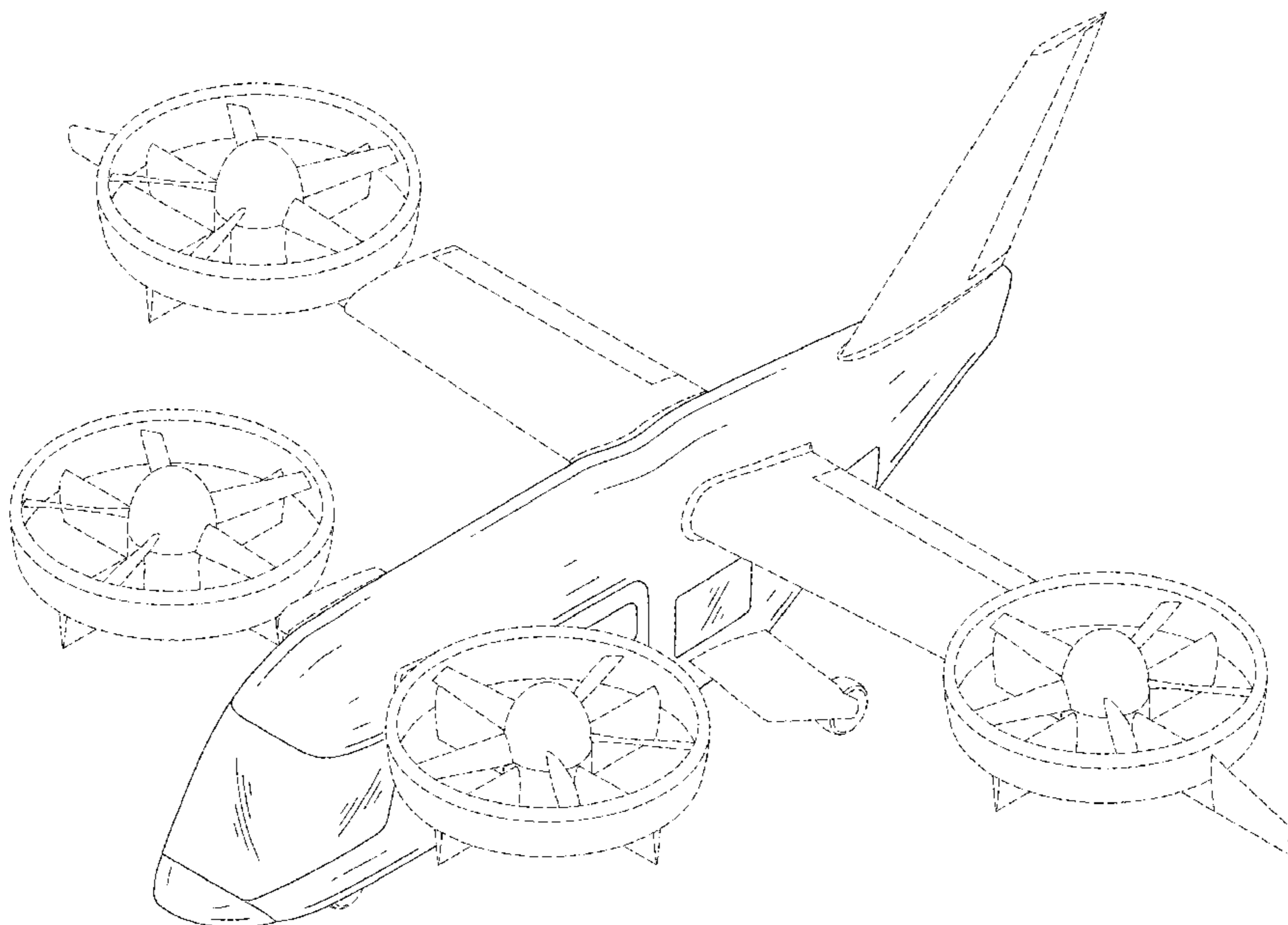

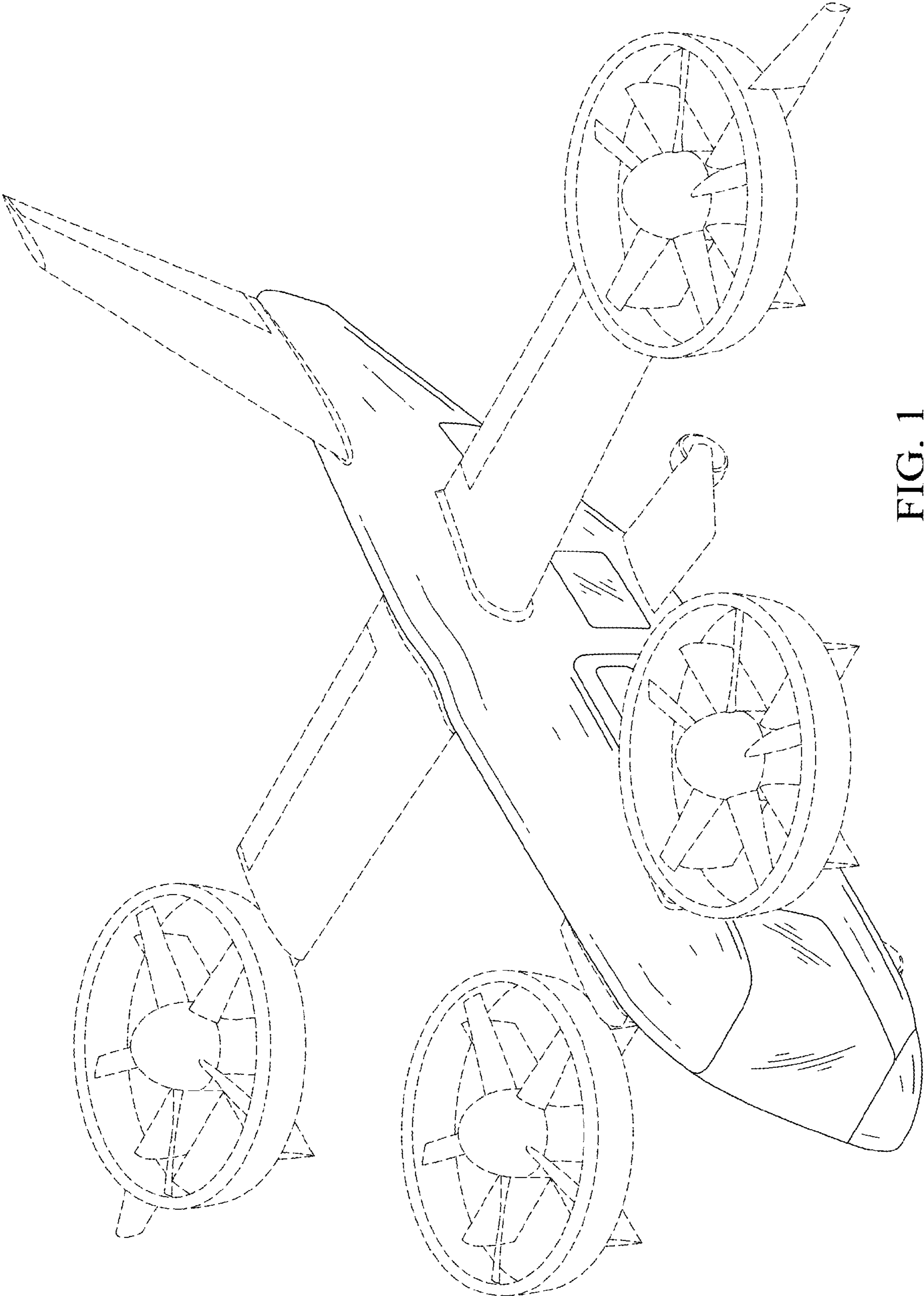

FIG. 1

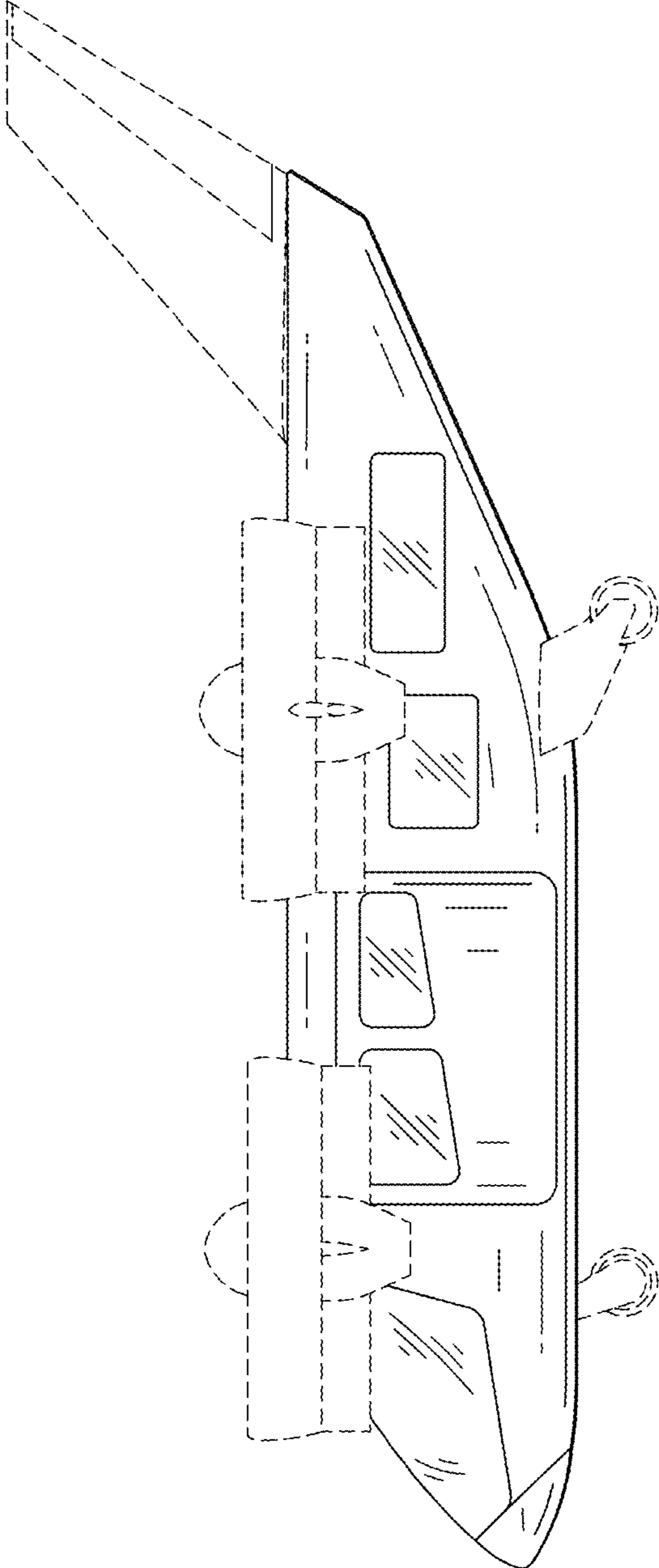
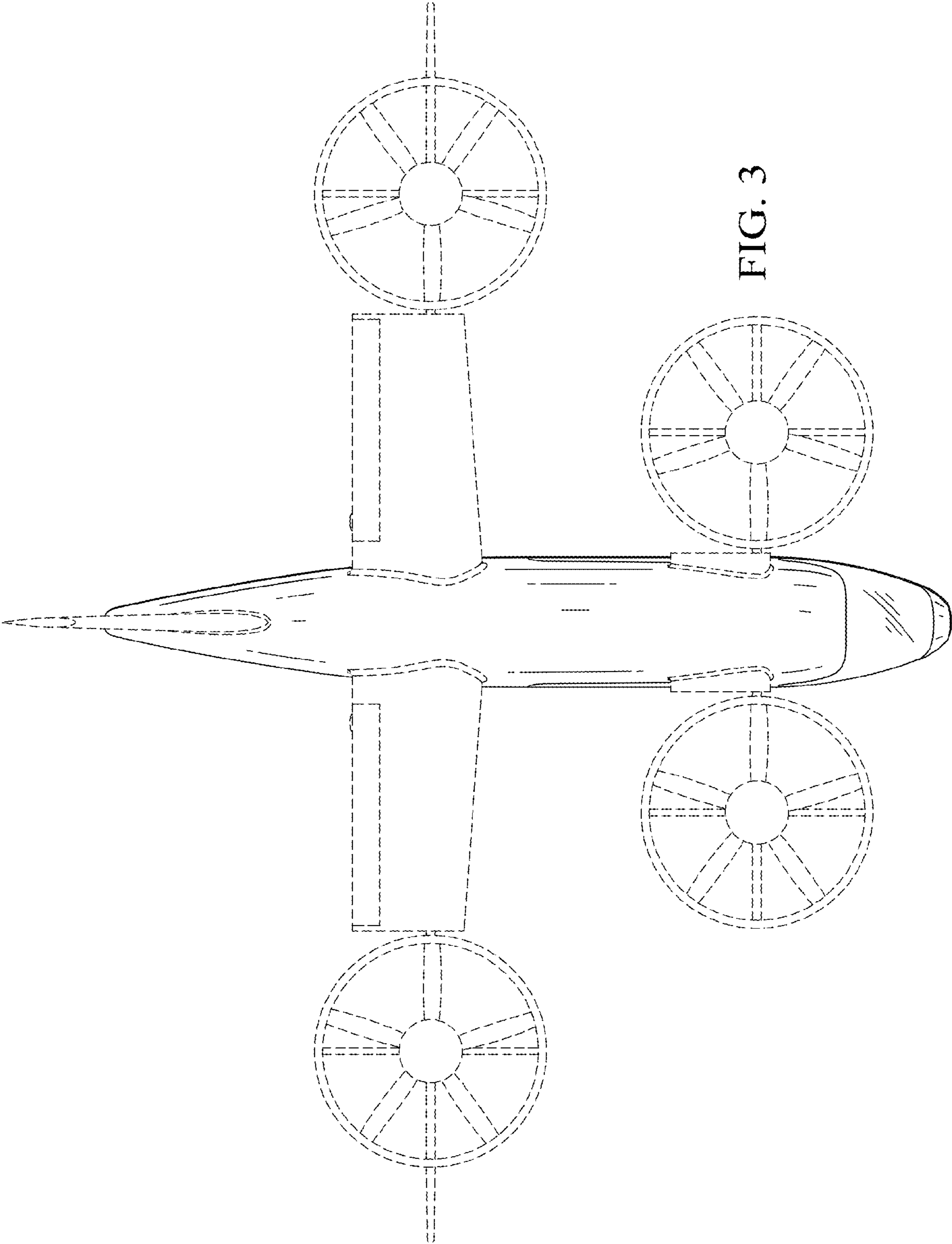

FIG. 2



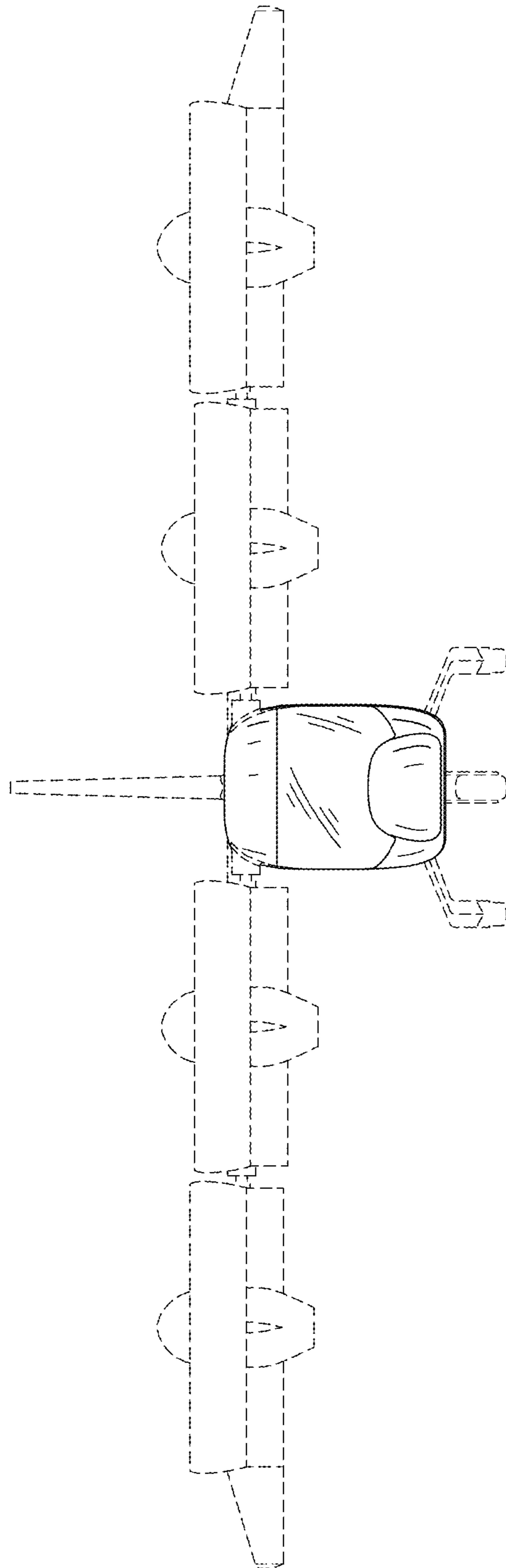

FIG. 4

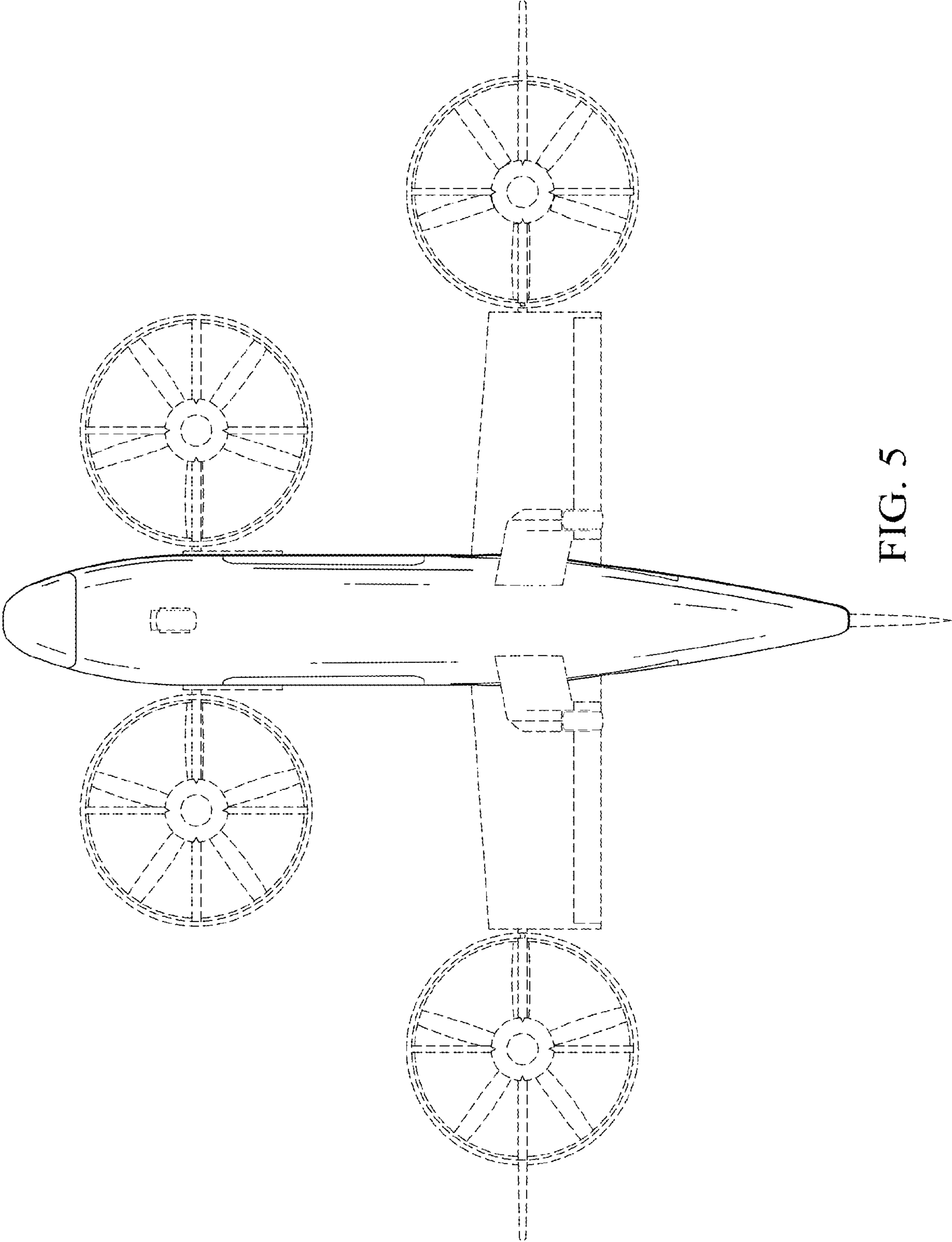

FIG. 5

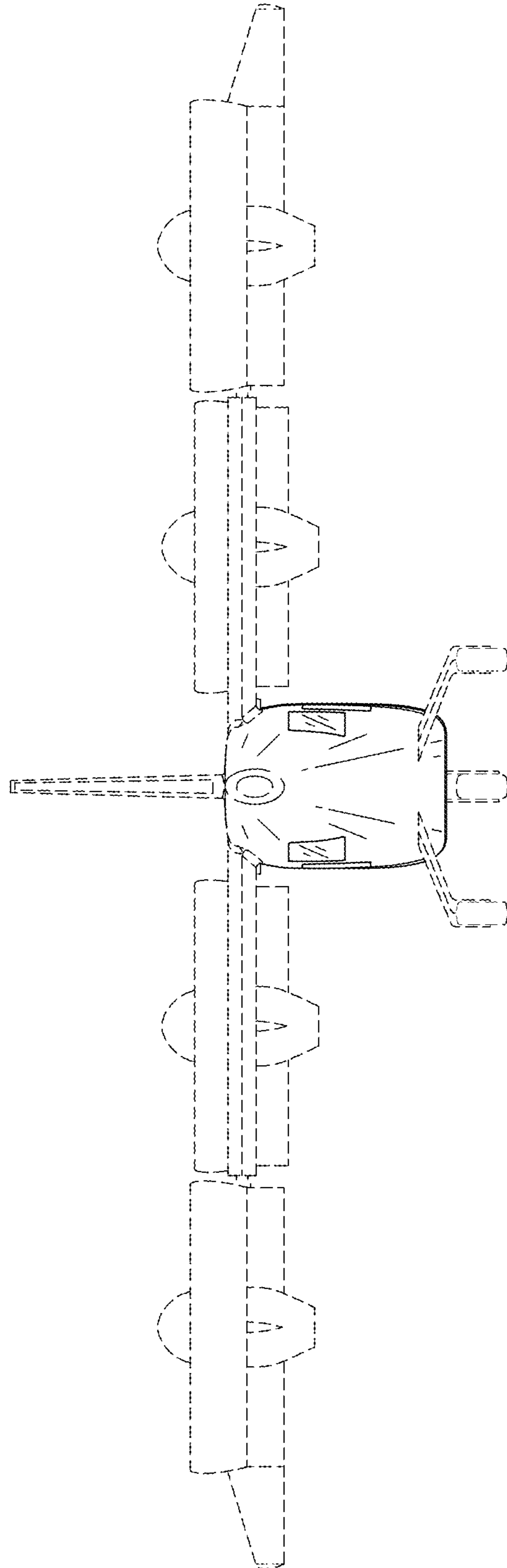

FIG. 6