



US00D919208S

(12) **United States Design Patent** (10) **Patent No.:** **US D919,208 S**  
**Garner** (45) **Date of Patent:** **\*\* May 11, 2021**

(54) **PORTABLE CLEANING DEVICE**

(71) Applicant: **KÄRCHER NORTH AMERICA, INC., Denver, CO (US)**

(72) Inventor: **Trent Garner, Highlands Ranch, CO (US)**

(73) Assignee: **KÄRCHER NORTH AMERICA, INC., Denver, CO (US)**

(\*\*) Term: **15 Years**

(21) Appl. No.: **29/699,636**

(22) Filed: **Jul. 26, 2019**

(51) **LOC (13) Cl.** ..... **15-05**

(52) **U.S. Cl.**  
USPC ..... **D32/15**

(58) **Field of Classification Search**  
USPC ..... D32/15-16, 1, 20-21  
CPC ..... B05B 9/04; B05B 7/24; B24C 1/00  
See application file for complete search history.

(56) **References Cited**

**U.S. PATENT DOCUMENTS**

2,170,890	A	8/1939	Allen	
2,896,862	A	7/1959	Bede	
3,321,110	A	5/1967	Price	
3,403,818	A	10/1968	Enssle	
D221,021	S *	6/1971	Jones	D32/21
4,093,123	A	6/1978	Maran	
4,678,010	A	7/1987	Purvis et al.	
4,708,088	A	11/1987	Purvis et al.	
D337,185	S *	7/1993	Wulff	D32/15
D341,913	S *	11/1993	Swan	D32/15
5,478,015	A	12/1995	Black	
D370,320	S *	5/1996	Hachtmann	D32/16
D375,590	S *	11/1996	Steinhart	D32/15
5,735,461	A	4/1998	Winther	
5,890,258	A *	4/1999	Lee	A47L 11/30 15/320

6,158,669	A	12/2000	Louis	
D467,692	S *	12/2002	Morgan	D32/15
6,557,542	B1	5/2003	Orr	
6,565,015	B2	5/2003	Leer et al.	
D475,488	S *	6/2003	Bisson	D32/15
6,695,228	B2	2/2004	Odessa	
6,981,613	B1	1/2006	Kamisugi	
D525,000	S *	7/2006	Williams	D32/15
D529,670	S *	10/2006	Hendy	D32/15

(Continued)

**FOREIGN PATENT DOCUMENTS**

CA	1326983	2/1994
EP	0451942	10/1991
WO	WO D100224-001	* 3/2020

**OTHER PUBLICATIONS**

Karcher PS 4/7 Bp Veterinary-Grade Disinfectant Sprayer, greenplanet scientific website 2020.\*

(Continued)

*Primary Examiner* — John R Yeh

(74) *Attorney, Agent, or Firm* — Sheridan Ross P.C.

(57) **CLAIM**

The ornamental design of a portable cleaning device, as shown and described.

**DESCRIPTION**

FIG. 1 is a front perspective of the portable cleaning device; FIG. 2 is a front elevation view thereof; FIG. 3 is a rear elevation view thereof; FIG. 4 is a right elevation view thereof; FIG. 5 is a left elevation view thereof; FIG. 6 is a top plan view thereof; and, FIG. 7 is a bottom plan view thereof. The broken lines depict portions of the portable cleaning device that form no part of the claimed design.

**1 Claim, 7 Drawing Sheets**

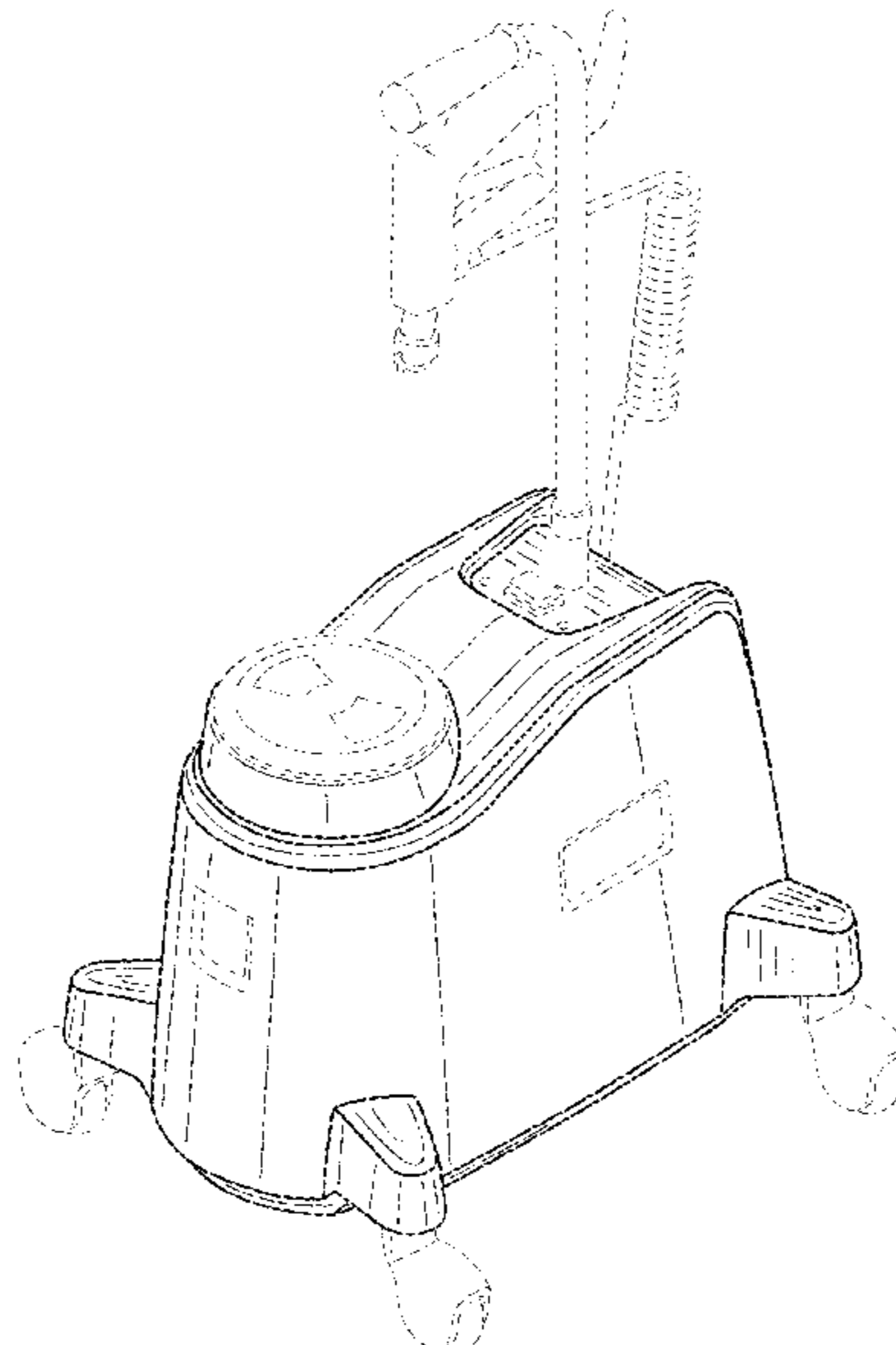

(56)

References Cited

U.S. PATENT DOCUMENTS

D542,988 S \* 5/2007 Dammkoehler ..... D32/16  
 D549,405 S \* 8/2007 Dammkoehler ..... D32/16  
 D568,009 S \* 4/2008 Lam ..... D32/21  
 D570,058 S \* 5/2008 Watson ..... D32/1  
 D571,512 S \* 6/2008 Dammkoehler ..... D32/15  
 D580,605 S \* 11/2008 Rodenkirch ..... D32/15  
 D581,608 S \* 11/2008 Dammkoehler ..... D32/21  
 D639,001 S \* 5/2011 Alexander ..... D32/15  
 8,047,455 B2 11/2011 Reedy  
 D703,888 S \* 4/2014 Kahan ..... D32/16  
 D712,605 S \* 9/2014 Dammkoehler ..... D32/21  
 D714,501 S \* 9/2014 Dammkoehler ..... D32/22  
 D720,900 S \* 1/2015 Hickmott ..... D32/21  
 D732,764 S \* 6/2015 Kennard ..... D32/15  
 9,421,563 B2 8/2016 Venard et al.  
 D779,138 S \* 2/2017 Jin ..... D32/16  
 D782,759 S \* 3/2017 Mathiassen ..... D32/21  
 D785,254 S \* 4/2017 Dammkoehler ..... D32/16  
 9,700,989 B1 \* 7/2017 Cooper ..... B24C 5/02  
 D793,635 S \* 8/2017 Dammkoehler ..... D32/16  
 D809,721 S \* 2/2018 Venard ..... D32/15  
 D824,613 S \* 7/2018 Alexander ..... D32/16  
 10,093,335 B2 \* 10/2018 Thuma ..... B62B 3/10  
 D834,269 S \* 11/2018 Masters ..... D32/15  
 10,119,101 B2 \* 11/2018 Peitersen ..... C11D 11/0064  
 D835,369 S \* 12/2018 Thakur ..... D32/15  
 D875,333 S \* 2/2020 Wall ..... D32/21  
 D876,733 S \* 2/2020 Hui ..... D32/21  
 10,555,657 B2 \* 2/2020 Pedlar ..... A47L 11/24  
 D882,193 S \* 4/2020 Bruneel ..... D32/21  
 D894,505 S \* 8/2020 Yang ..... D32/15

2008/0001007 A1 1/2008 Gilpatrick et al.  
 2011/0030724 A1 \* 2/2011 Alexander ..... B08B 3/026  
 134/6  
 2011/0237162 A1 \* 9/2011 Kostevich ..... B24C 7/0038  
 451/38  
 2012/0226764 A1 9/2012 Philip et al.  
 2012/0241537 A1 9/2012 Schwei et al.

OTHER PUBLICATIONS

“UAC HA 10068C A/C Accumulator with Hose Assembly,” retrieved from [www.ebay.com/ctg/UAC-HA-10068C-A-C-Accumulator-Hose-Assembly-/79151059](http://www.ebay.com/ctg/UAC-HA-10068C-A-C-Accumulator-Hose-Assembly-/79151059), retrieved on Dec. 4, 2013, 2 pages.  
 “Mobile 12 Volt accumulator-pressure cleaner,” retrieved from <http://www.frankana.de/search.do?search=Mobile+12+Volt+accumulator-pressure+cleaner>, retrieved on May 4, 2015, 1 page.  
 “PurePak—Improving patient care and infection control, while reducing costs,” PureTech Systems, 2 pages.  
 “PurePak—Providing More Complete Coverage, While Saving Time,” PureTech Systems, 2 pages.  
 “PurePak—Frequently Asked Questions,” PureTech Systems, 2 pages.  
 “PurePak—Effectively control the spread of infections,” PureTech Systems, 1 page.  
 “PurePak—Operating Room Study,” PureTech Systems, 25 pages.  
 “PurePak—Proposal,” PureTech Systems, 27 pages.  
 “PureTech—Capabilities Summary,” PureTech Systems, 1 page.  
 Official Action for U.S. Appl. No. 14/573,993, dated Jan. 21, 2016, 6 pages.  
 Notice of Allowance for U.S. Appl. No. 14/573,993, dated Apr. 28, 2016, 5 pages.

\* cited by examiner

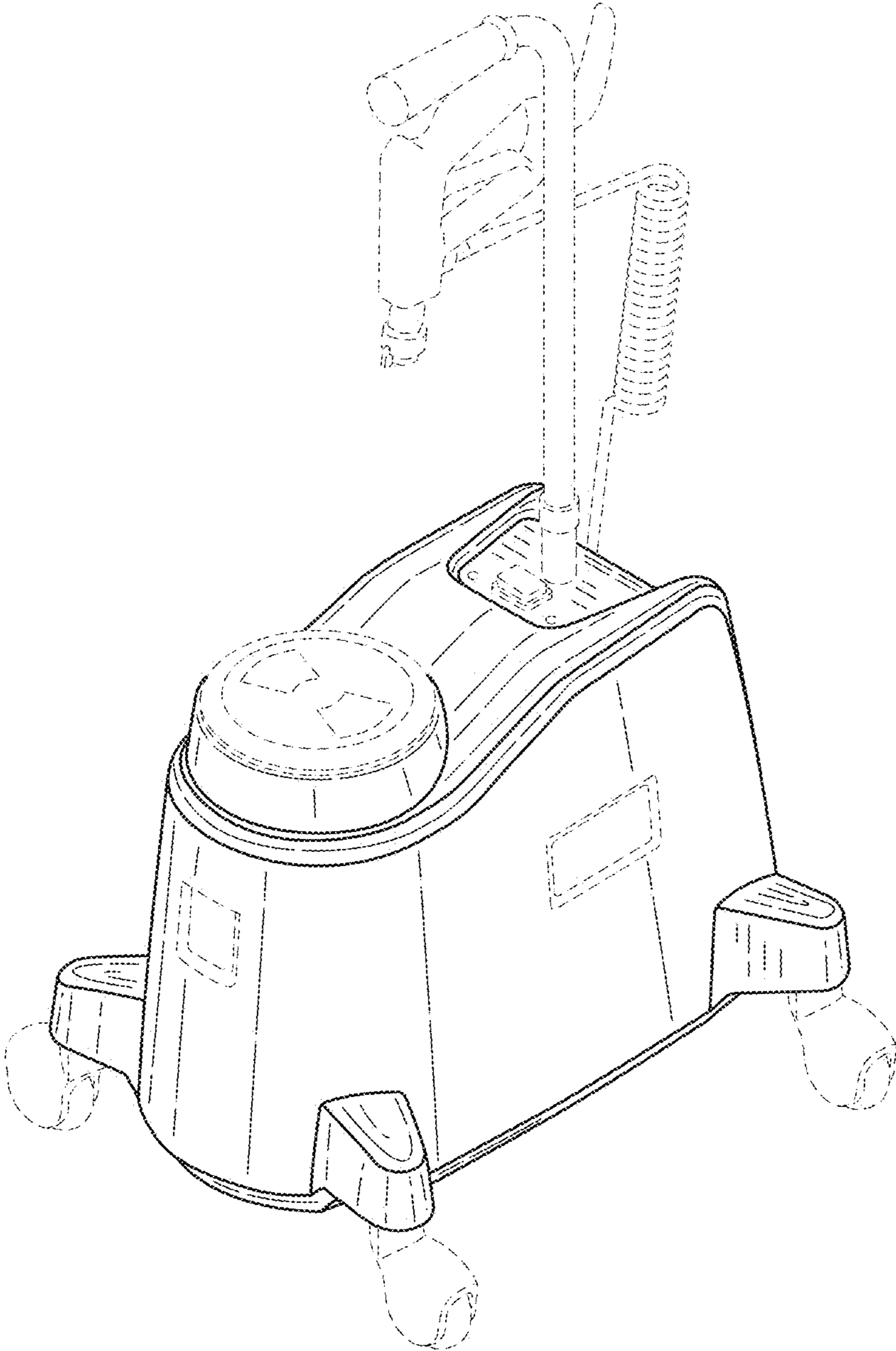

FIG.1

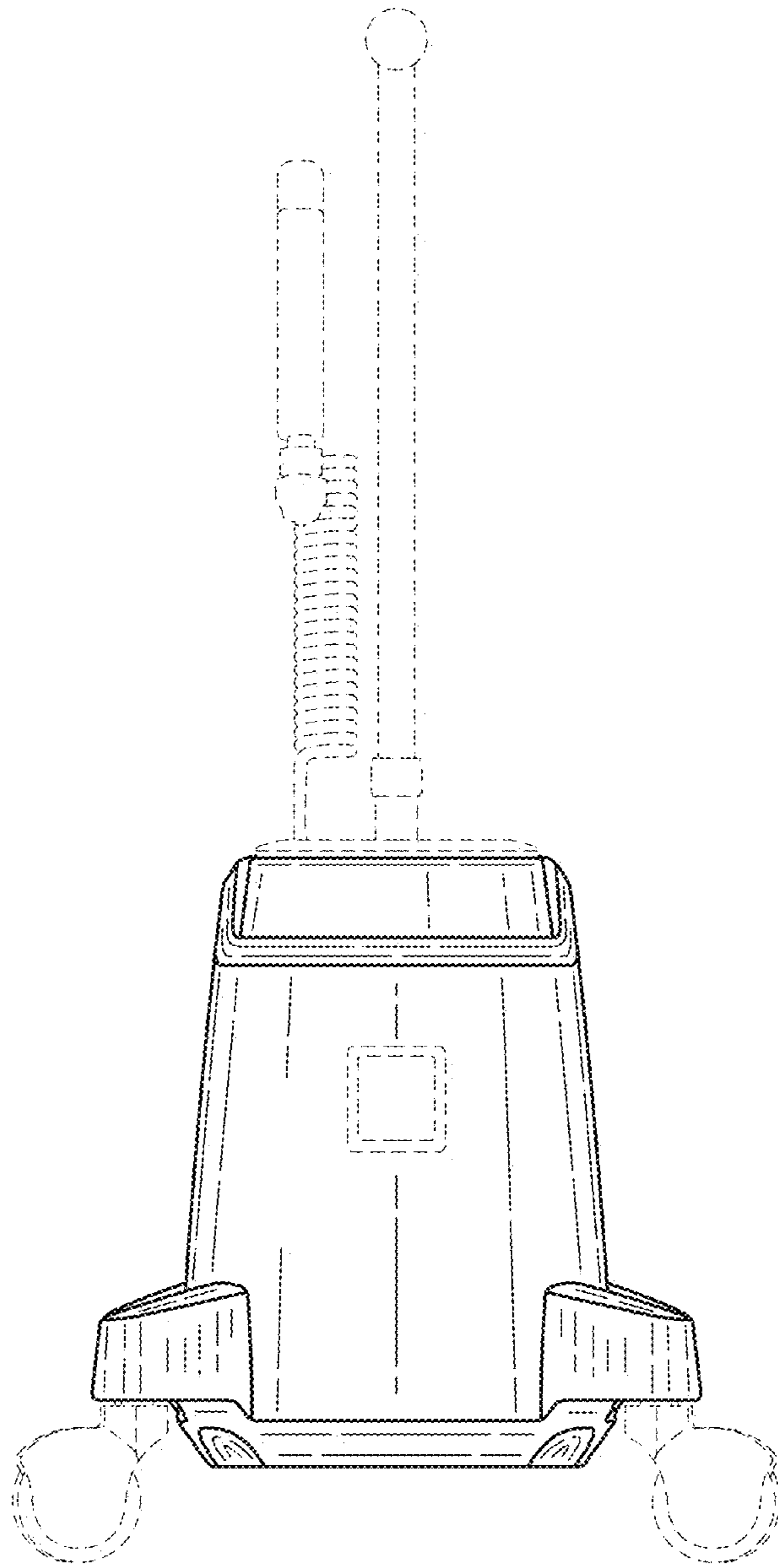

FIG.2

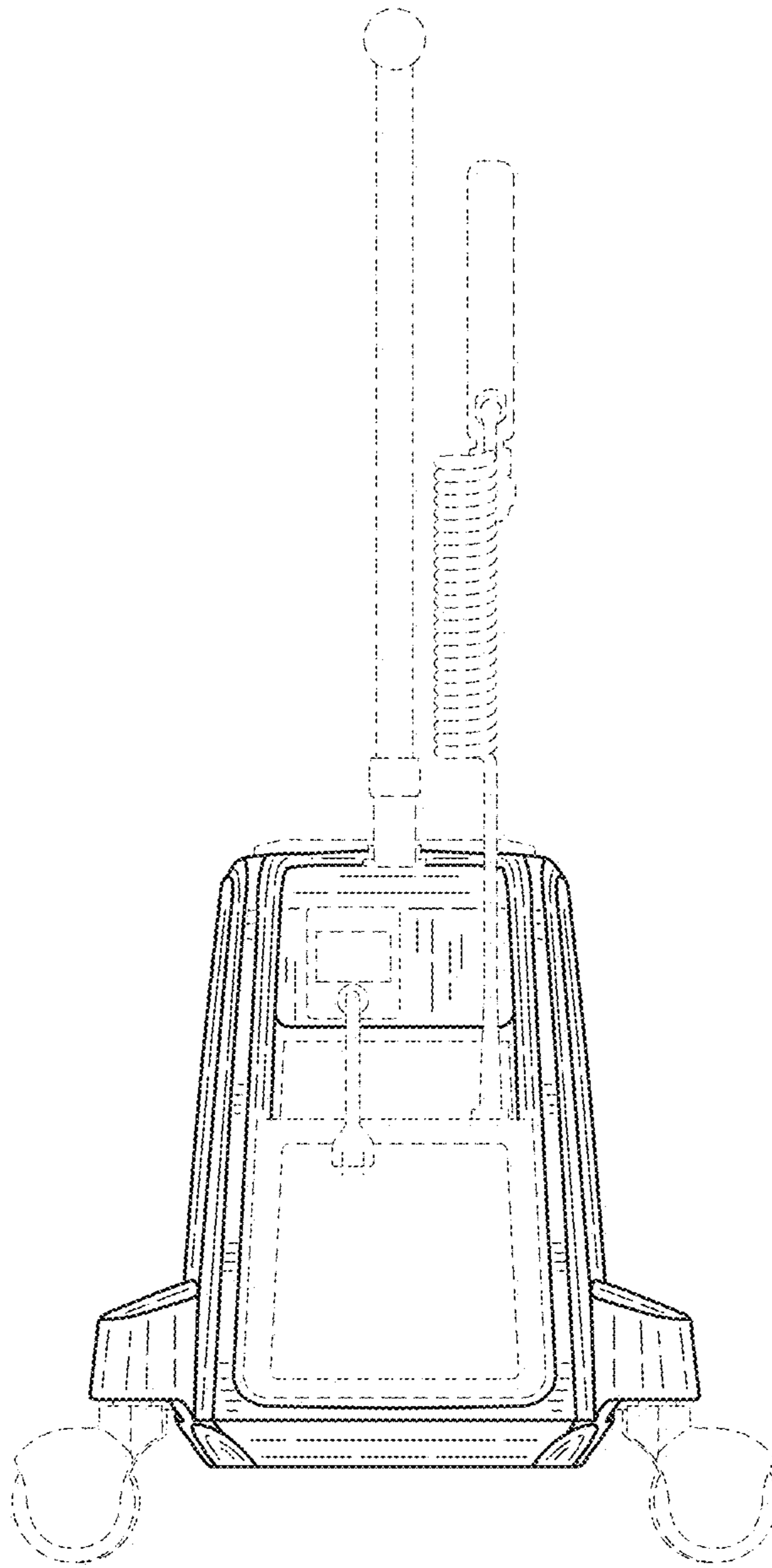

FIG.3

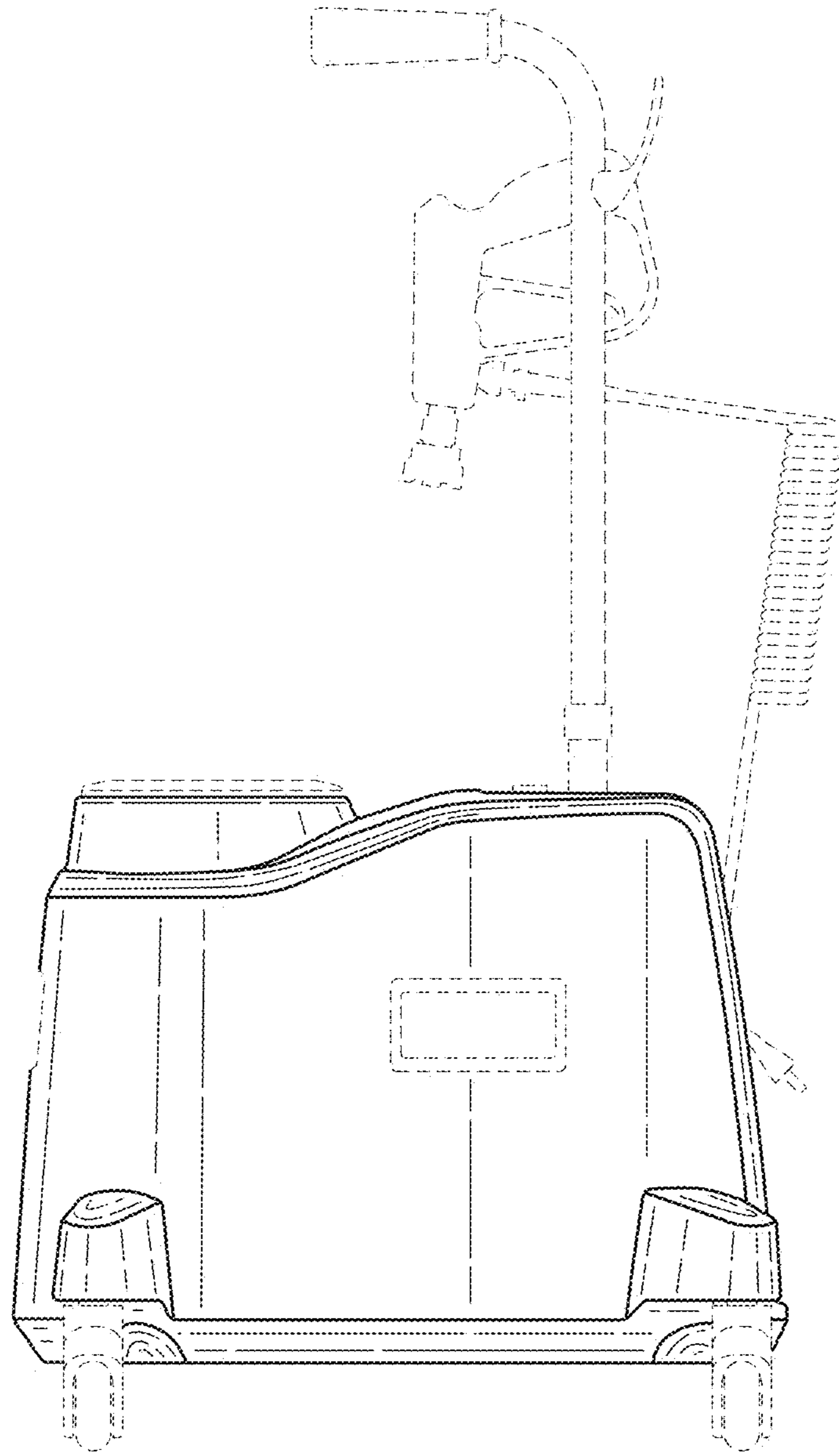

FIG.4

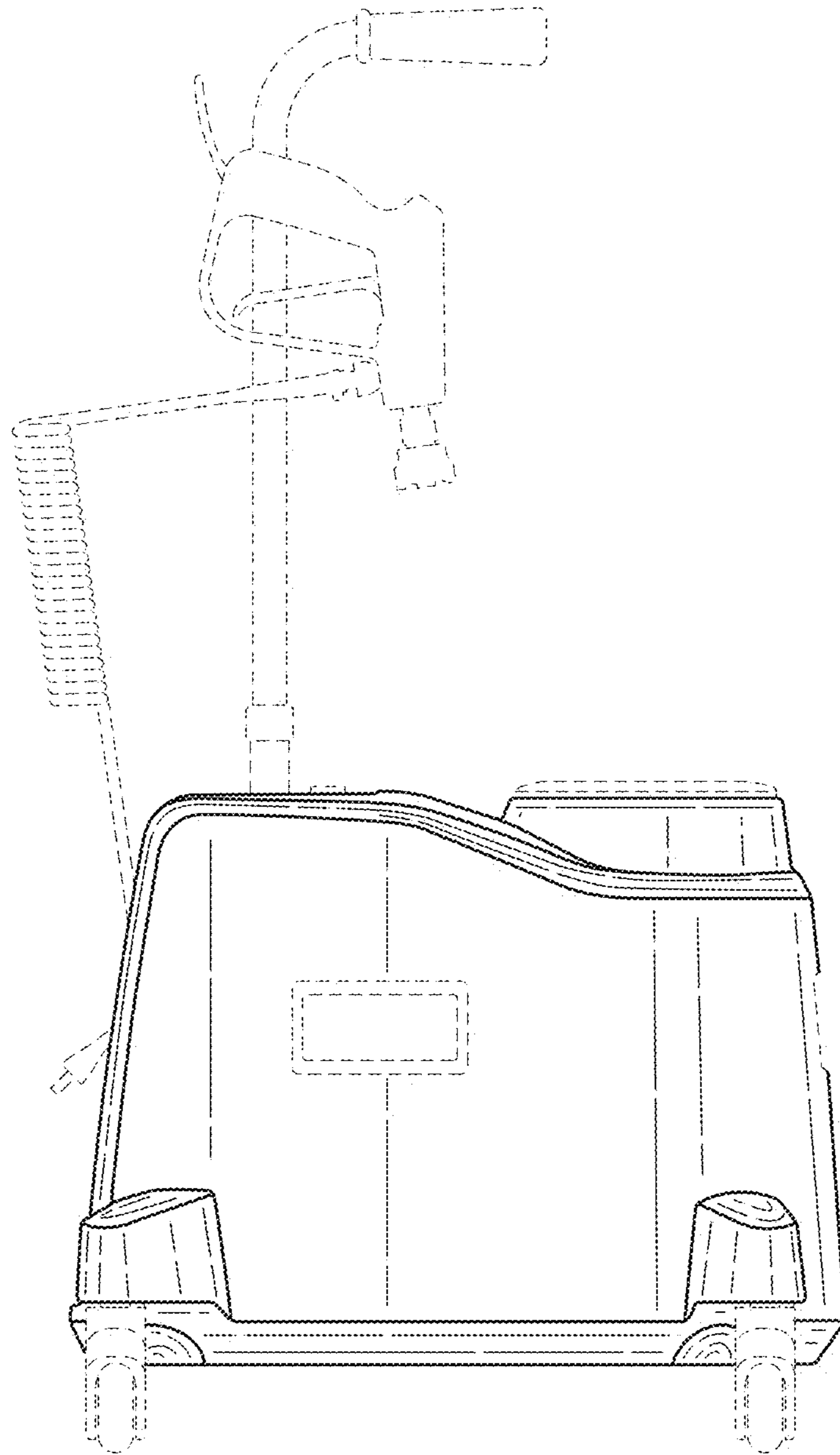

FIG.5

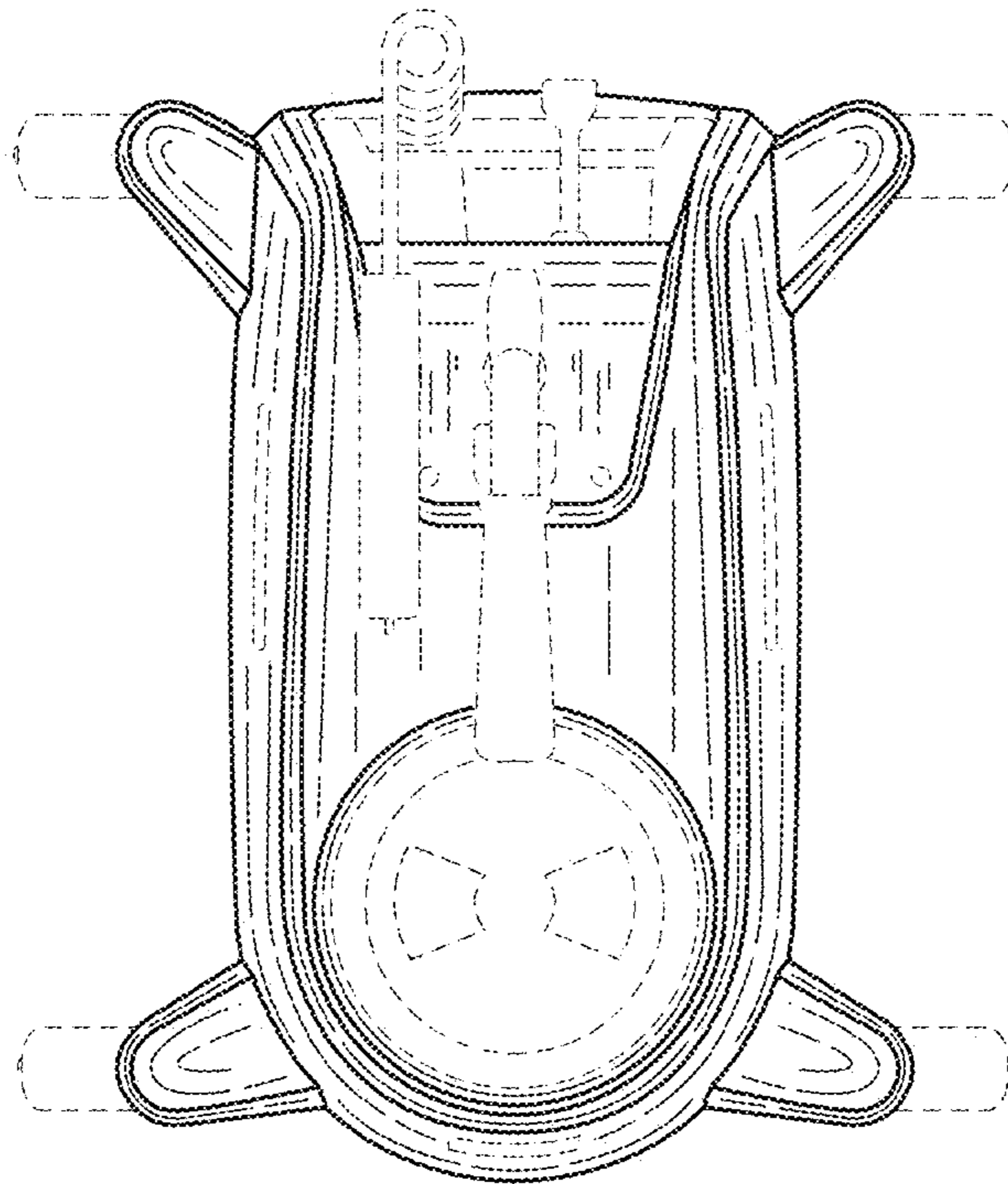

FIG.6



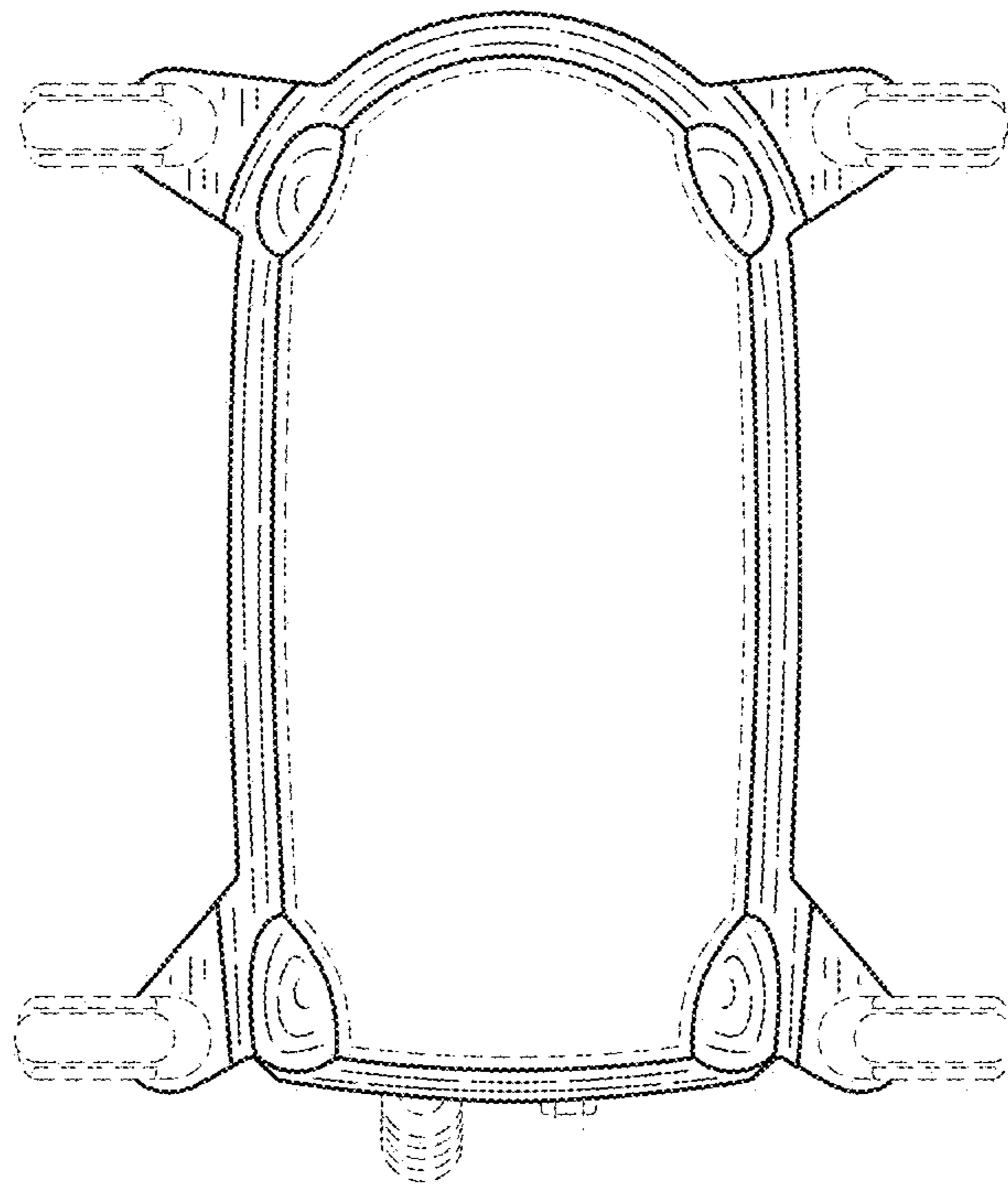

FIG.7