



US00D919080S

(12) **United States Design Patent** (10) **Patent No.:** **US D919,080 S**
Lee et al. (45) **Date of Patent:** **** May 11, 2021**

(54) **BREATHING TUBE CONNECTOR FOR A RESPIRATORY GAS EXCHANGE MONITOR**

(71) Applicant: **MediPines Corporation**, Anaheim Hills, CA (US)

(72) Inventors: **Steve Lee**, Anaheim Hills, CA (US); **Douglas Patton**, Irvine, CA (US)

(73) Assignee: **MediPines Corporation**, Anaheim Hills, CA (US)

(**) Term: **15 Years**

(21) Appl. No.: **29/649,517**

(22) Filed: **May 30, 2018**

(51) **LOC (13) Cl.** **24-02**

(52) **U.S. Cl.**
USPC **D24/110; D24/129; D24/164**

(58) **Field of Classification Search**
USPC **D24/107-108, 127, 129, 110, 110.5, D24/110.6, 164**

CPC **A61B 5/08; A61B 5/091; A61B 5/087; A61B 5/097; A61B 5/0871**

See application file for complete search history.

(56) **References Cited**

U.S. PATENT DOCUMENTS

D238,712 S *	2/1976	Gray	D24/110
D335,343 S *	5/1993	Jones	D24/110
5,598,839 A *	2/1997	Niles	A61M 16/08 128/205.23
D411,010 S *	6/1999	Harbrecht	D24/164
D439,663 S *	3/2001	Guala	D24/129
D441,070 S *	4/2001	Niles	D24/110
D483,869 S *	12/2003	Tran	D24/129
D489,129 S *	4/2004	King	D24/110

(Continued)

OTHER PUBLICATIONS

Medipines Advanced Single Patient Breathing Circuit. MediPines. Date accessed: May 20, 2020. Retrieved from Internet: <https://www.medipines.com/patient-breathing-circuit/> (Year: 2020).*

(Continued)

Primary Examiner — Lilyana Bekic

(74) *Attorney, Agent, or Firm* — Fish IP Law, LLP

(57) **CLAIM**

The ornamental design for a breathing tube connector for a respiratory gas exchange monitor, as shown and described.

DESCRIPTION

FIG. 1 is a perspective view of a breathing tube connector for a respiratory gas exchange monitor connected to a breathing tube;

FIG. 2 is a top view thereof;

FIG. 3 is a left side view thereof;

FIG. 4 is a rear view thereof;

FIG. 5 is a right side view thereof;

FIG. 6 is a front view thereof;

FIG. 7 is a bottom view thereof;

FIG. 8 is a perspective view of the breathing tube connector for a respiratory gas exchange monitor of FIG. 1;

FIG. 9 is a top view thereof;

FIG. 10 is a left side view thereof;

FIG. 11 is a rear view thereof;

FIG. 12 is a right side view thereof;

FIG. 13 is a front view thereof; and,

FIG. 14 is a bottom view thereof.

The broken lines showing of the breathing tube is for the purpose of illustrating environmental structure and forms no part of the claimed design. All other broken lines depict portions of the breathing tube connector for a respiratory gas exchange monitor that forms no part of the claimed design.

1 Claim, 9 Drawing Sheets

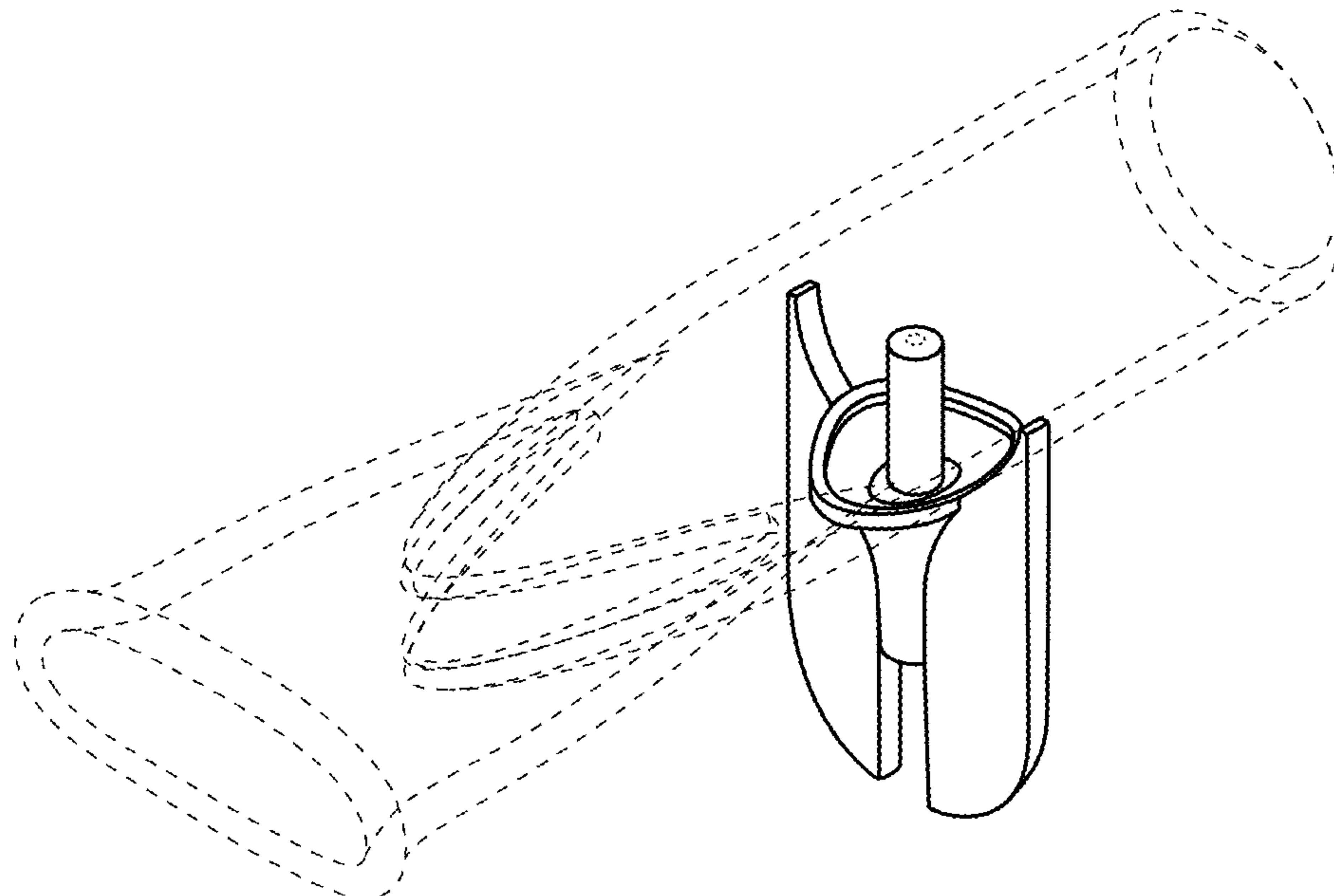

(56)

References Cited

U.S. PATENT DOCUMENTS

6,718,969 B1 * 4/2004 Rubin A61M 15/0086
128/200.14
D517,209 S * 3/2006 Burton D24/129
D556,908 S * 12/2007 Jones D24/164
D659,835 S * 5/2012 Benson D24/164
D694,410 S * 11/2013 Benson D24/164
D744,655 S * 12/2015 Benson D24/164
D754,329 S * 4/2016 Fleischer D24/110.5
D785,170 S * 4/2017 Swisher D24/129
D792,586 S * 7/2017 Becker D24/129
D797,927 S * 9/2017 Schuessler D24/129
D812,140 S 3/2018 Lee et al.
D870,290 S * 12/2019 Benson D24/164
2002/0073993 A1 * 6/2002 Weinstein A61B 5/0871
128/200.24

OTHER PUBLICATIONS

“Universal Disposable Mouthpieces by BD” Medline Industries, Inc., <https://www.medline.com/product/Universal-Disposable-Mouthpieces-by-Carefusion/Accessories/Z05-PF46936>, downloaded May 16, 2018, 1 page.

“Mouthpiece, for Non-Electric Spirometer, Disposable, Double One-Way Valves, Case of 25| Tri-anim Health Services” <https://www.tri-anim.com/non-electric-spirometer-mouthpieces-group-28696-3829.aspx>, downloaded May 16, 2018; 1 page.

* cited by examiner

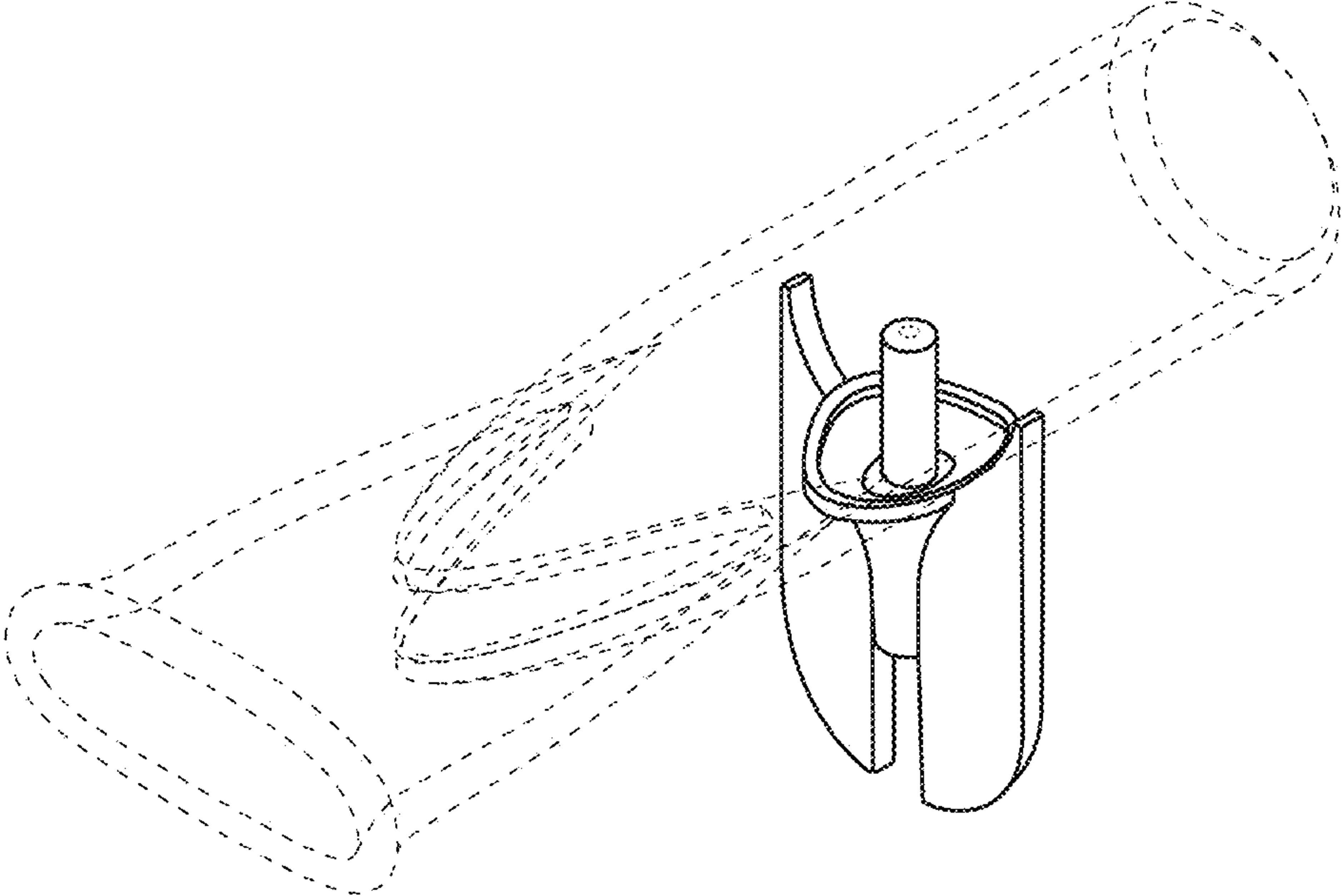

FIG. 1

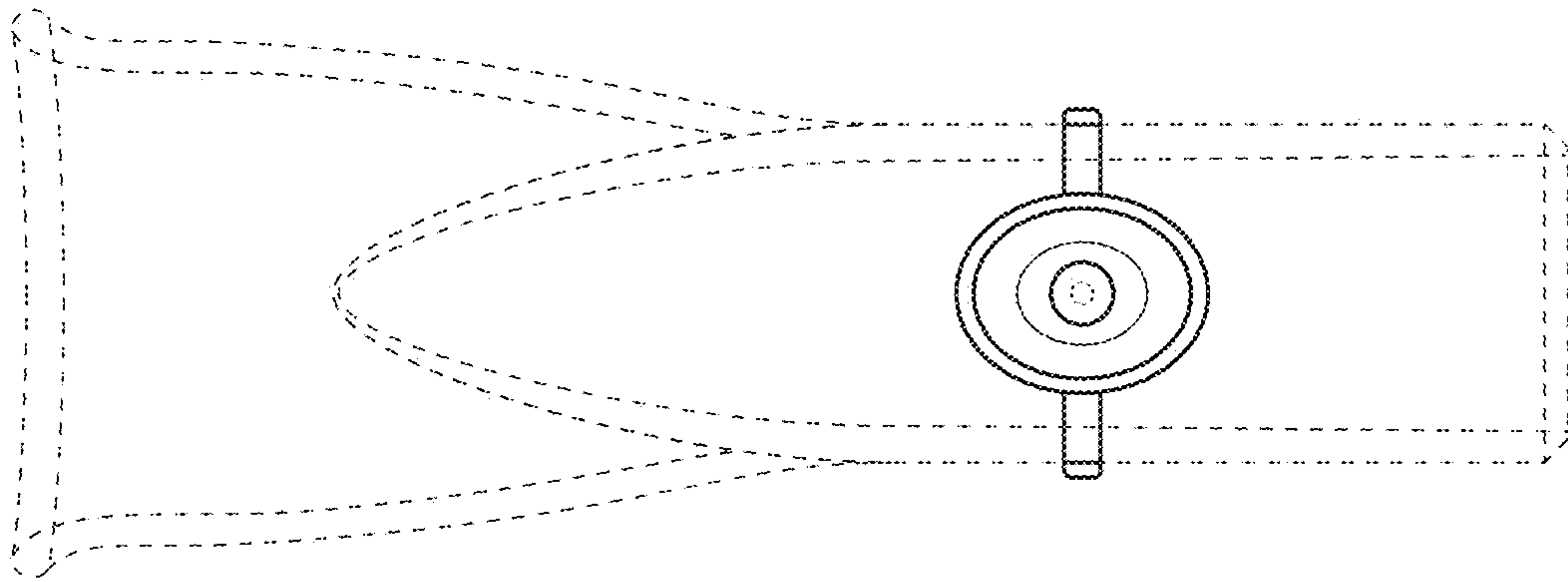

FIG. 2

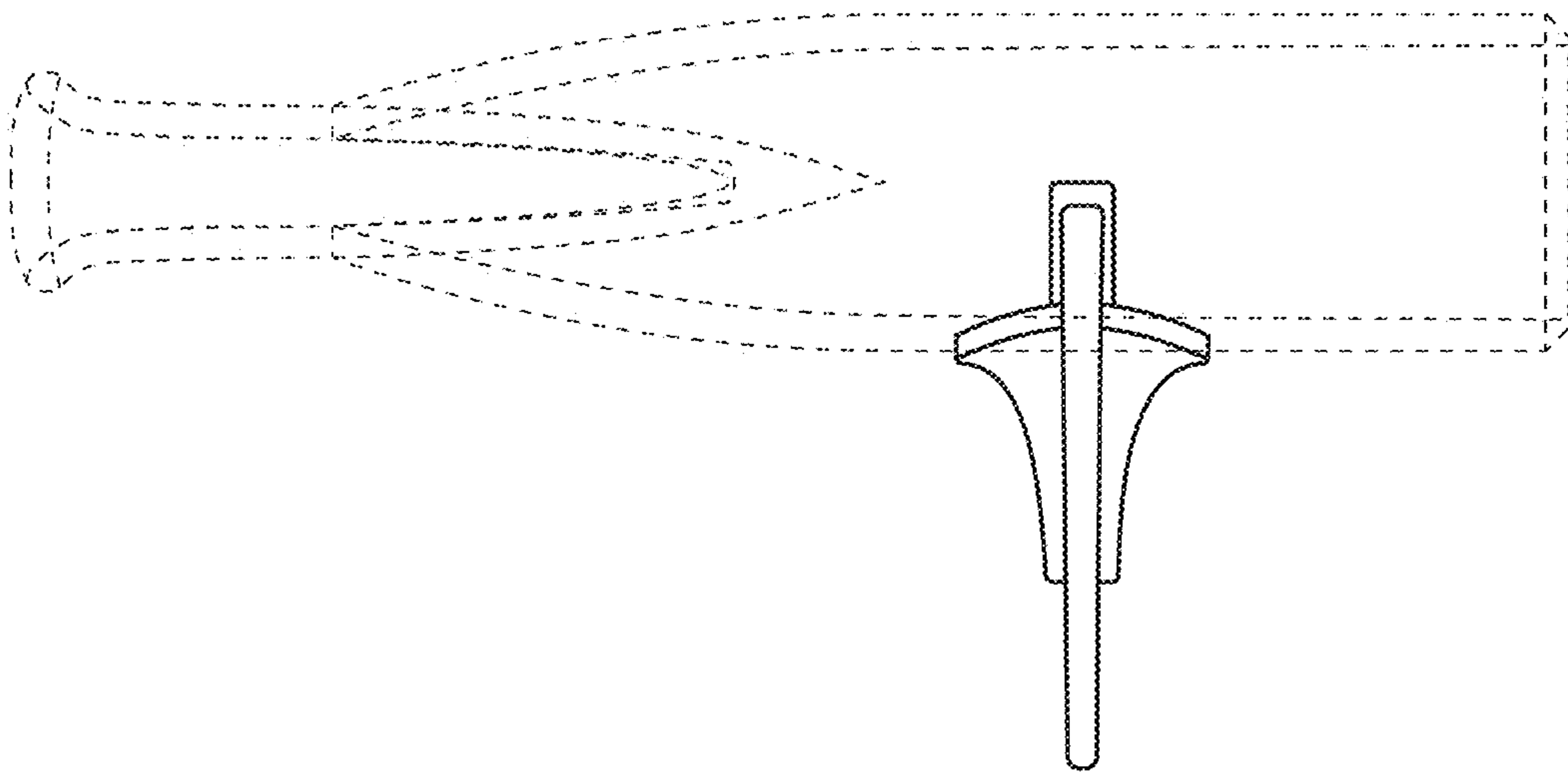

FIG. 3

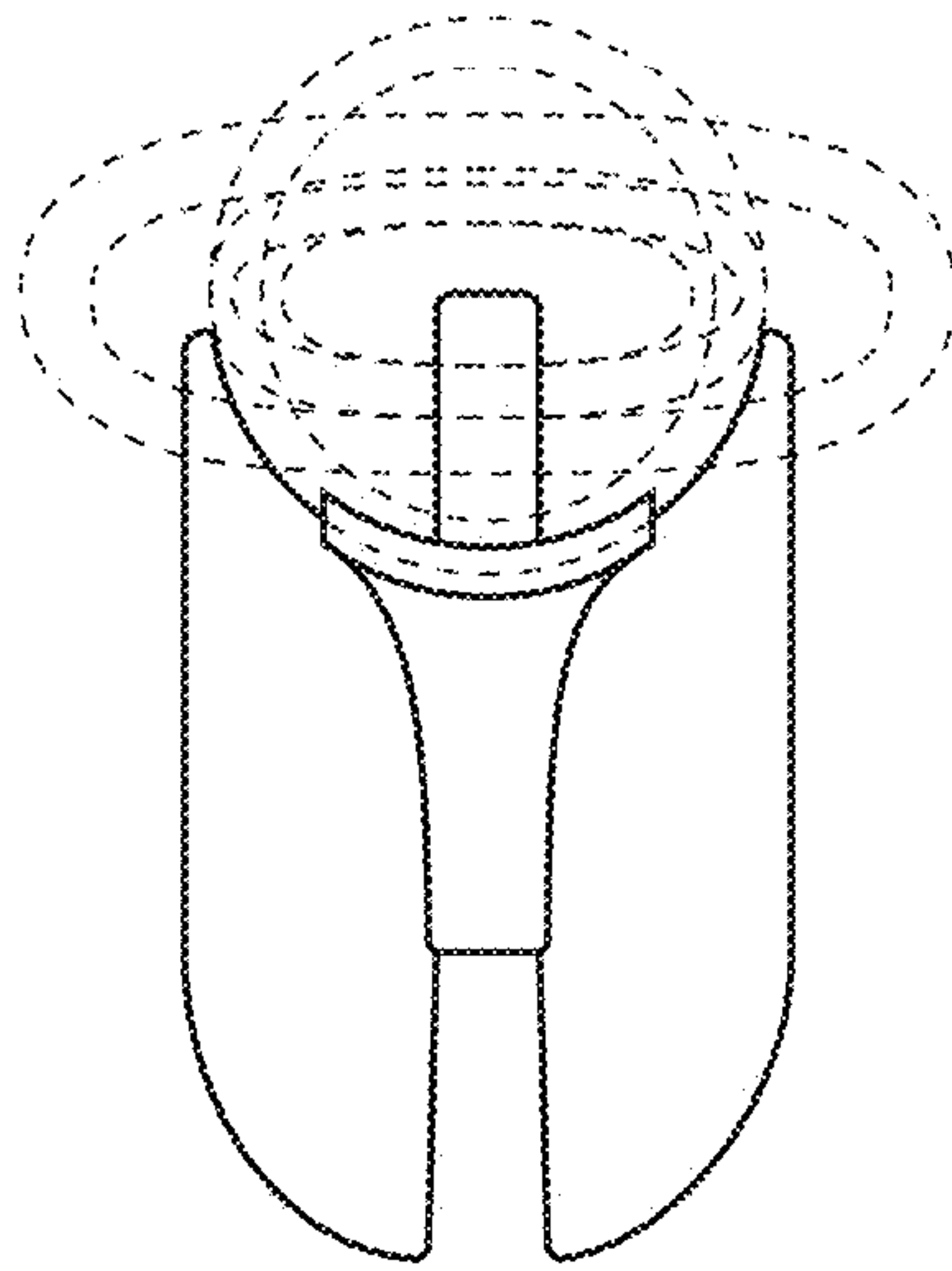

FIG. 4

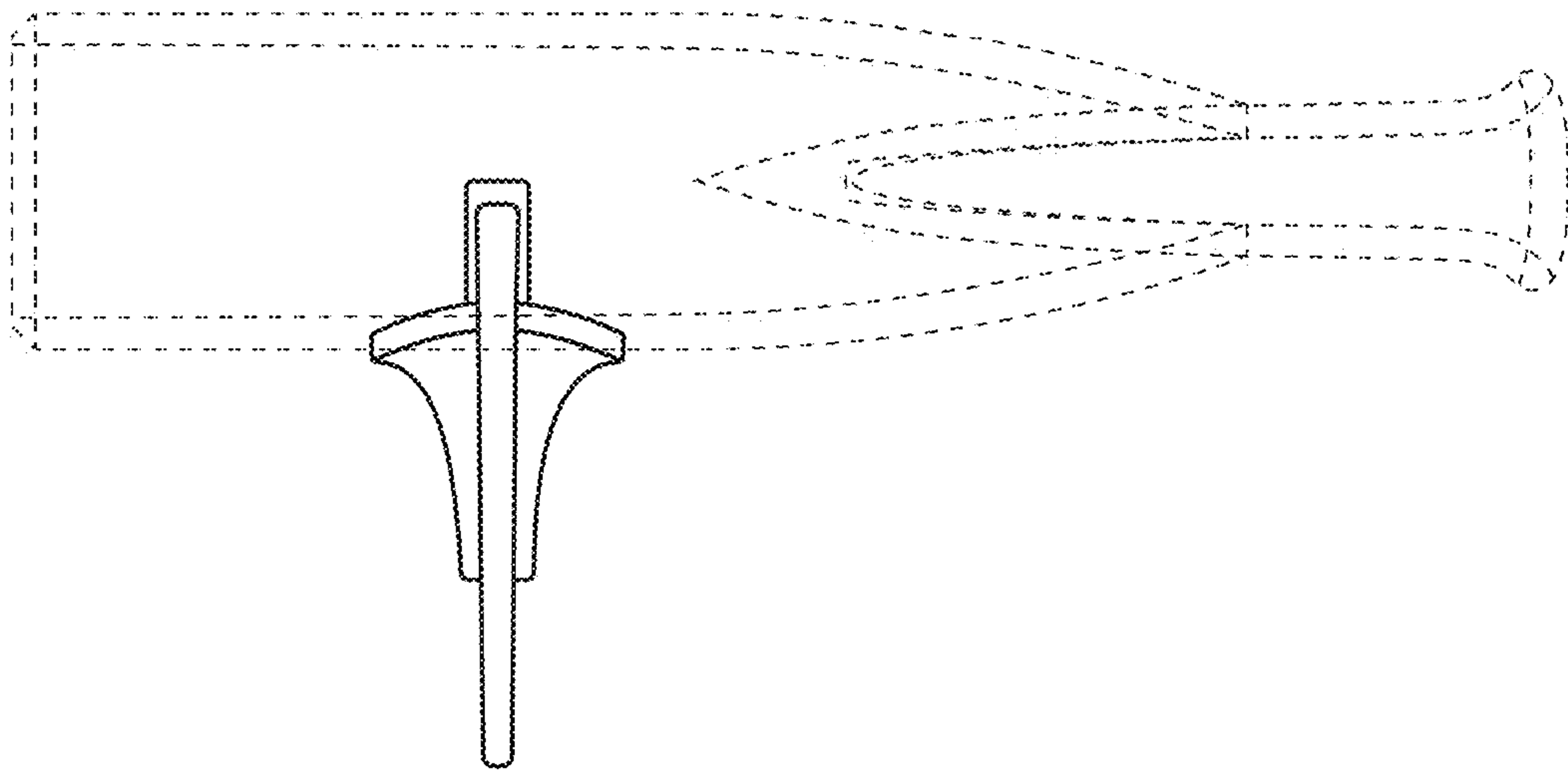

FIG. 5

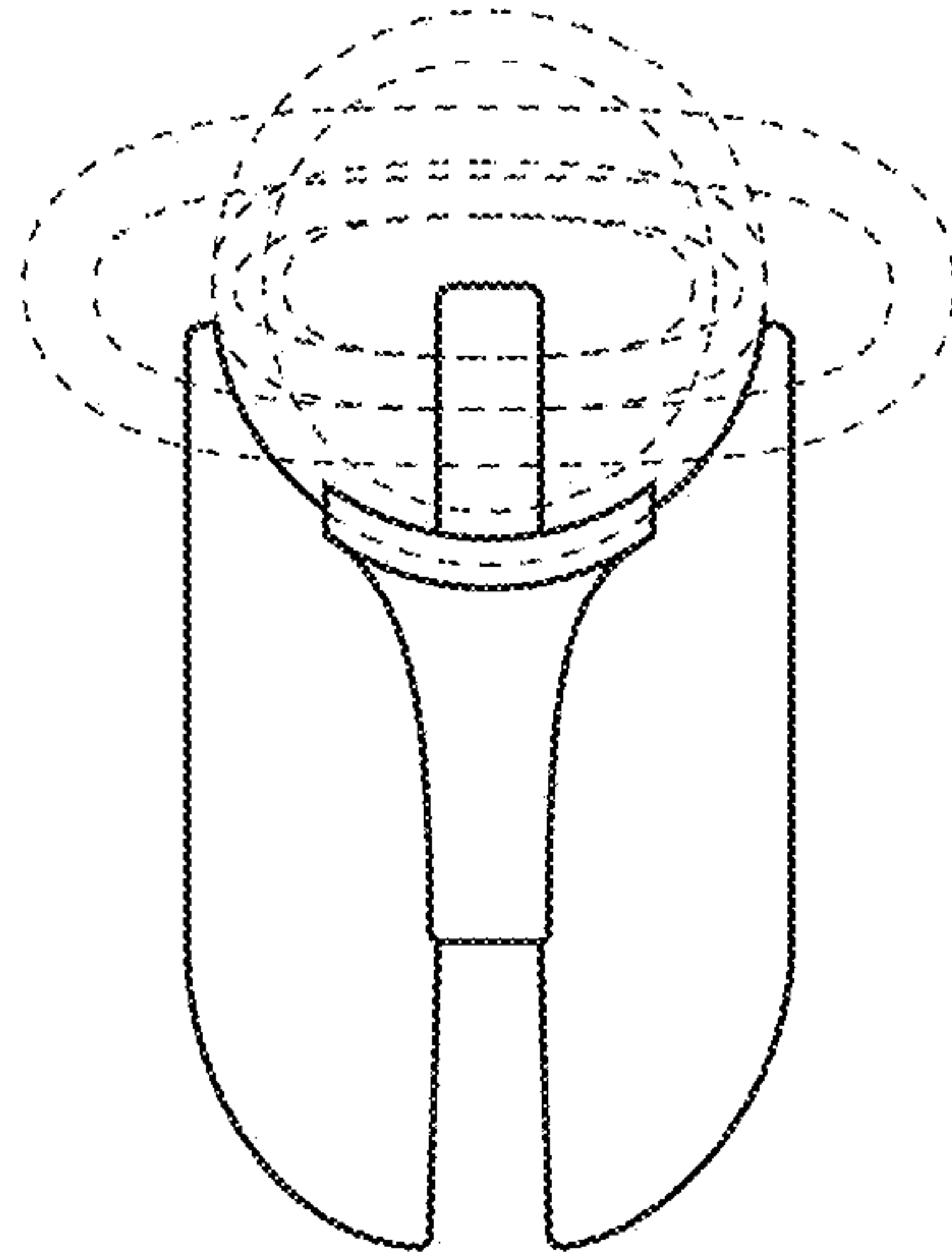

FIG. 6

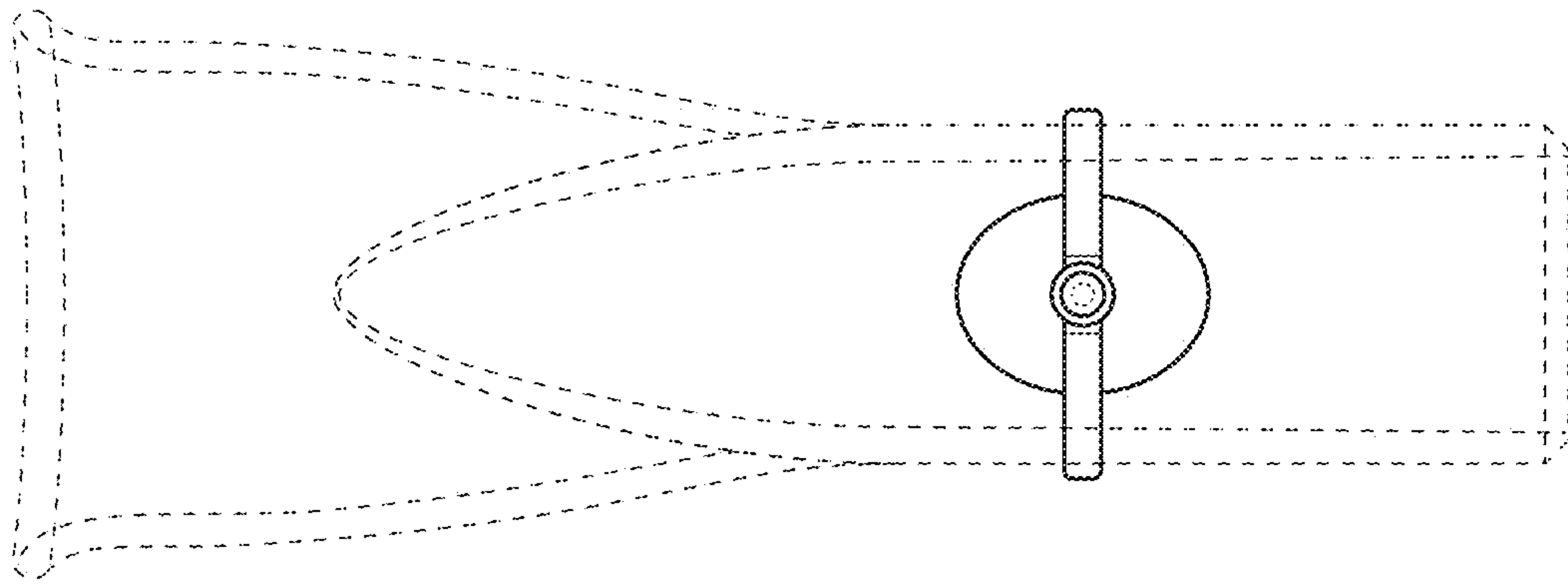

FIG. 7

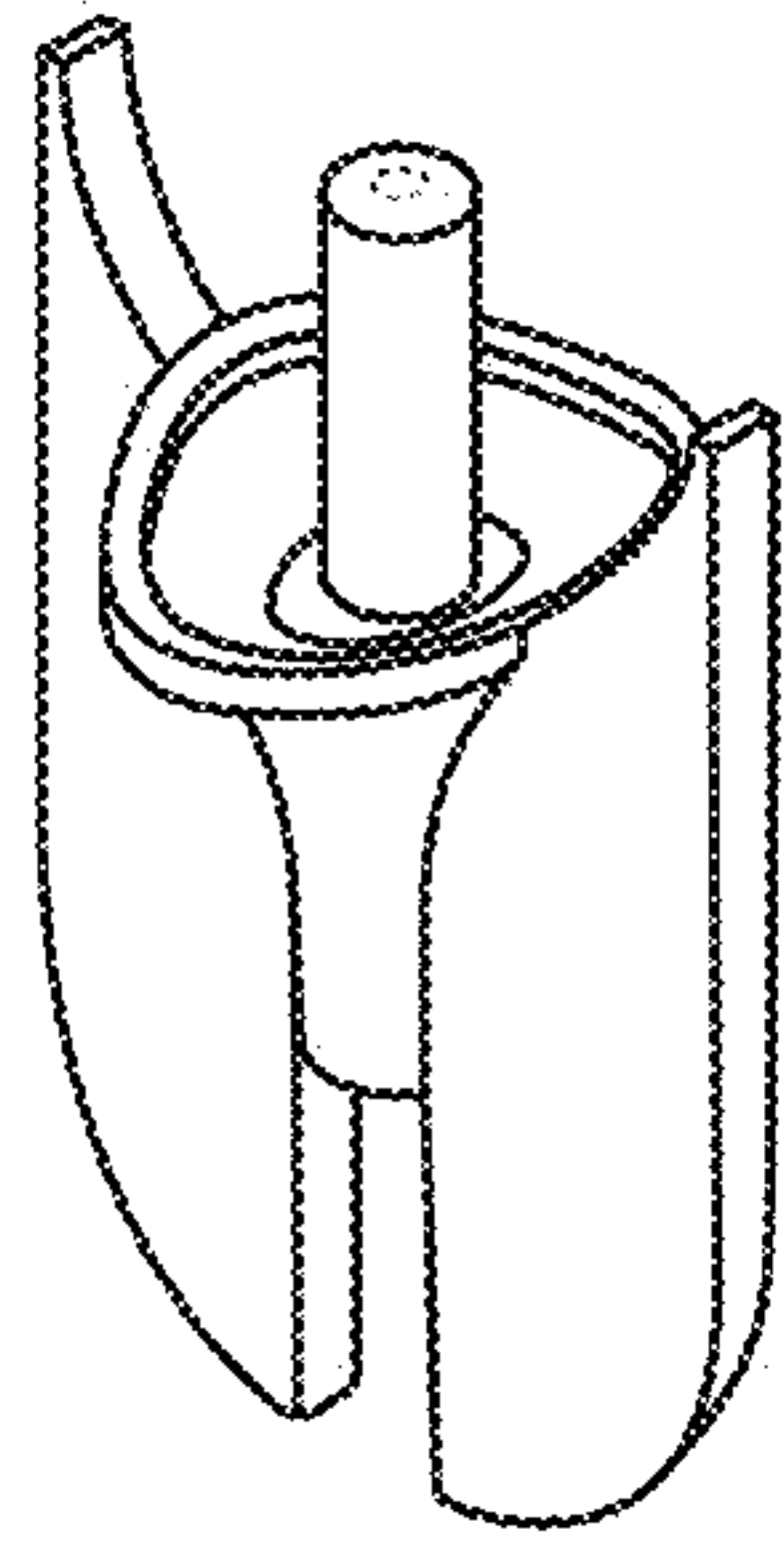

FIG. 8

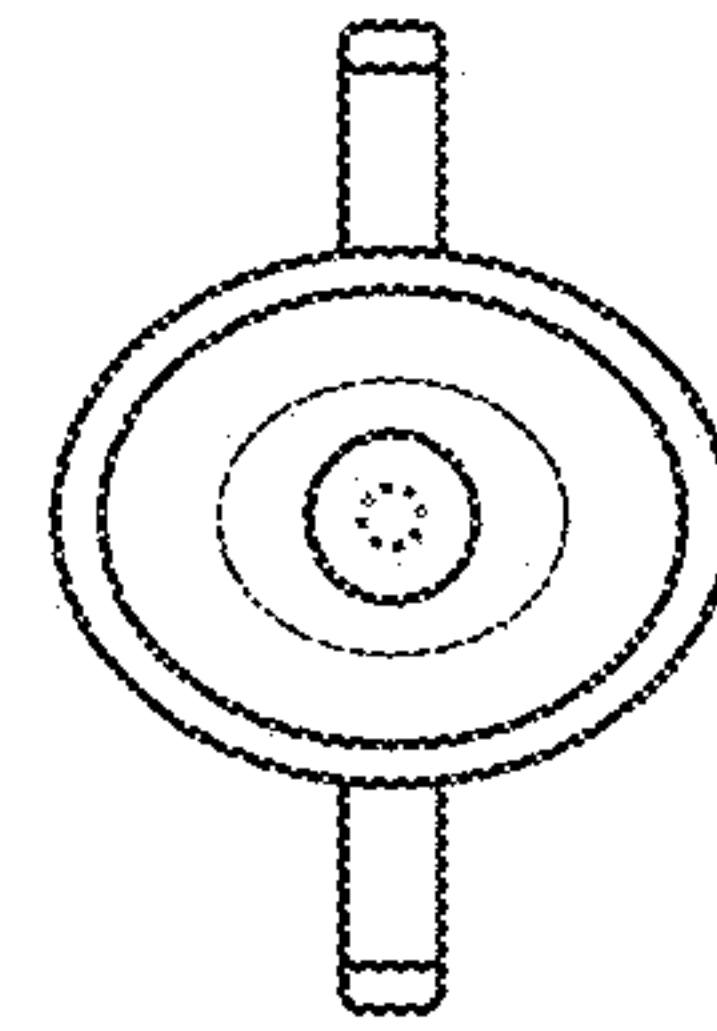

FIG. 9

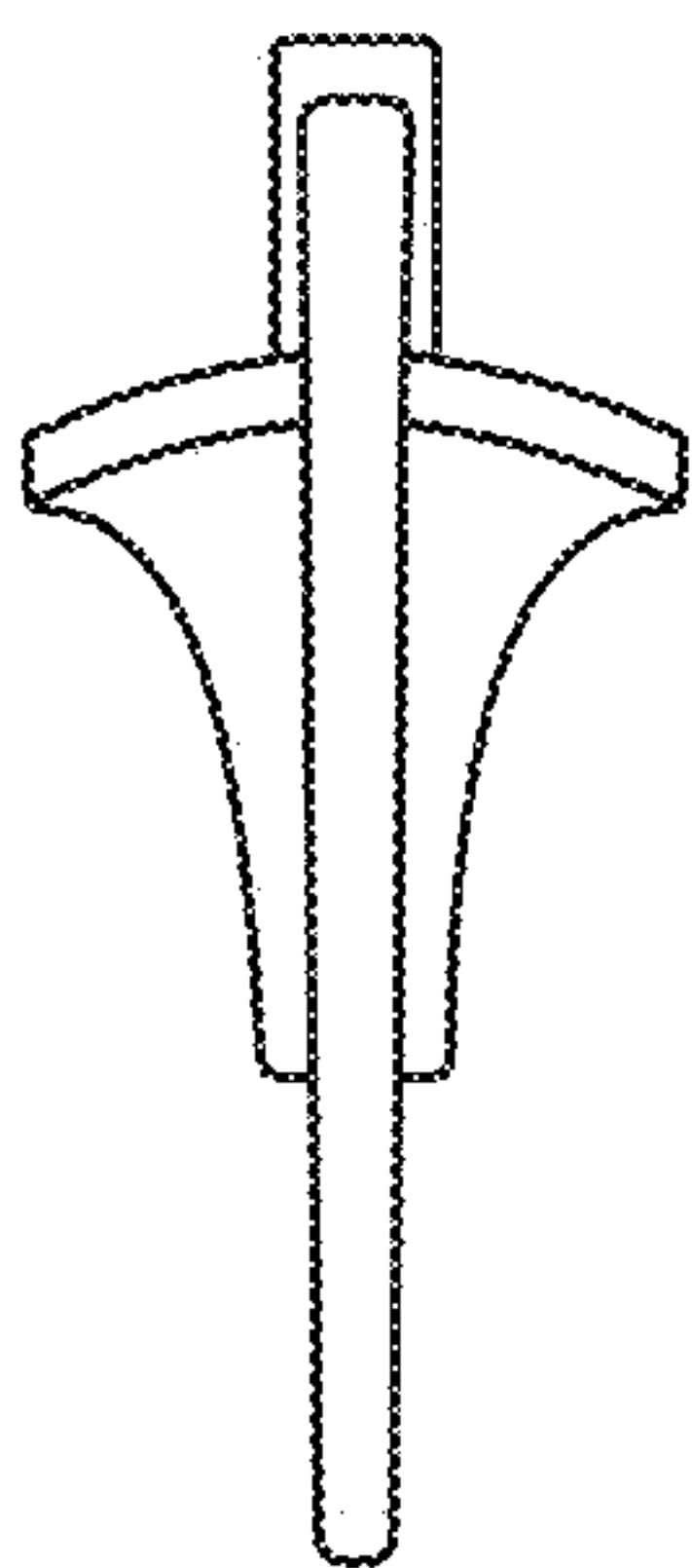

FIG. 10

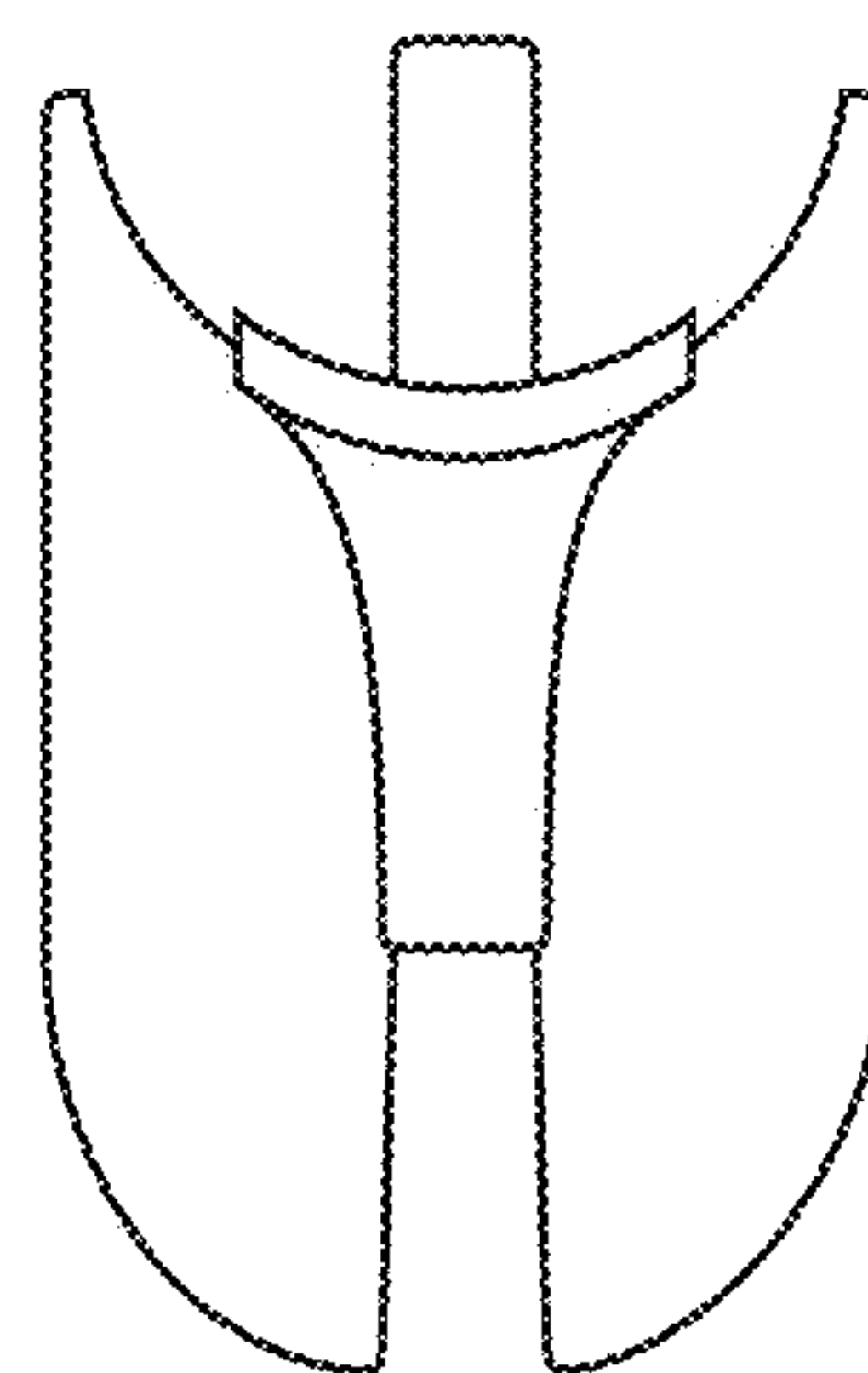

FIG. 11

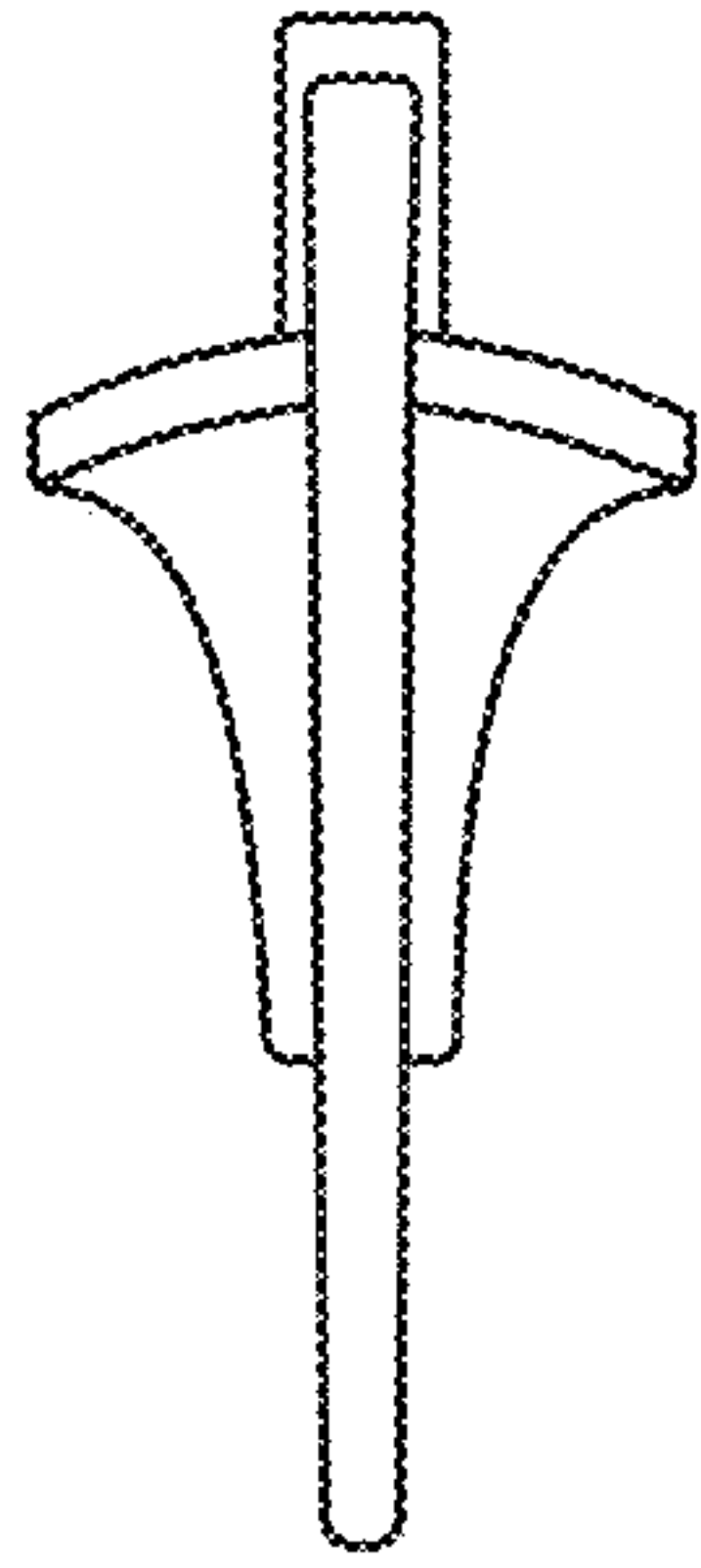

FIG. 12

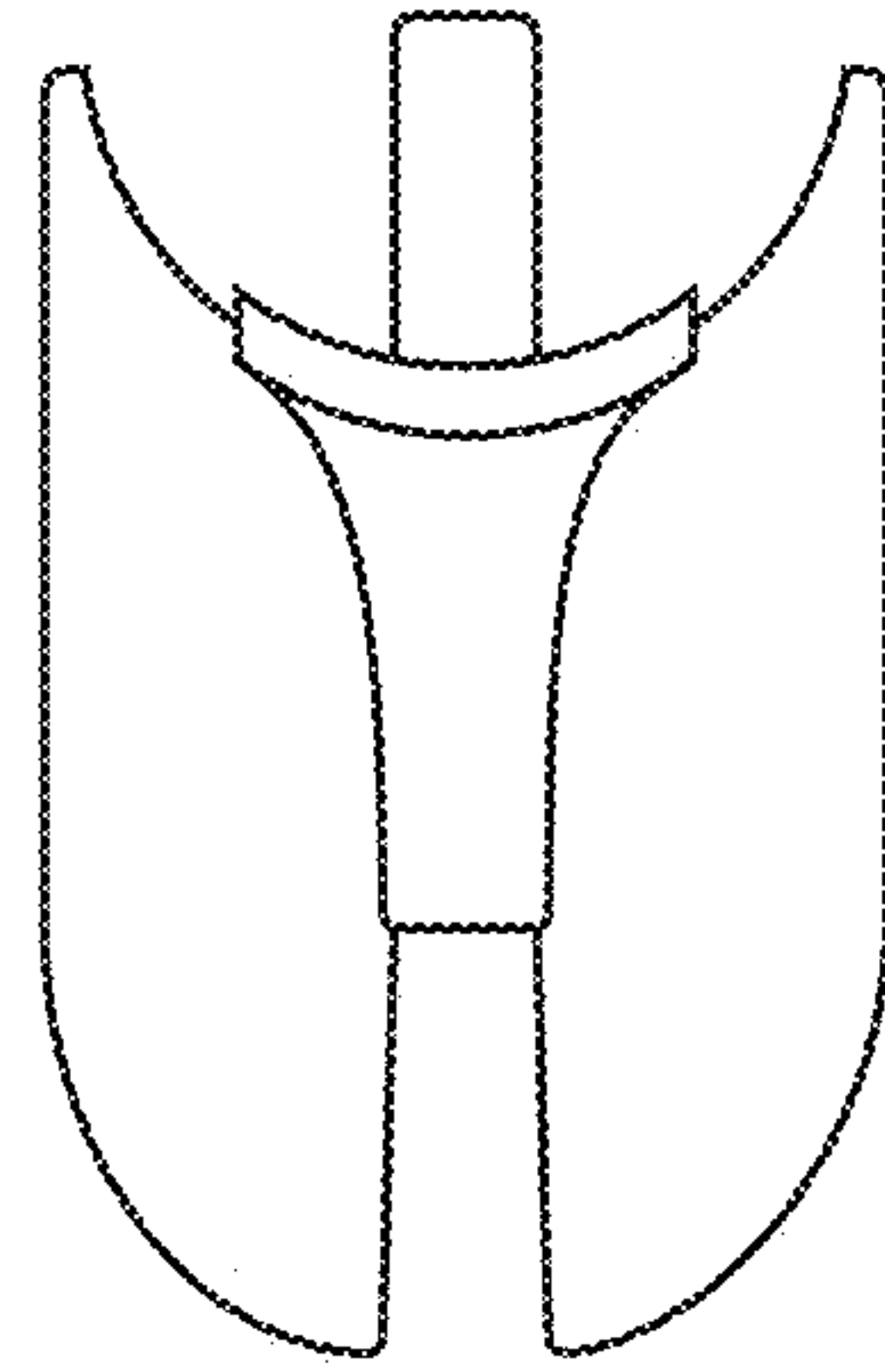

FIG. 13

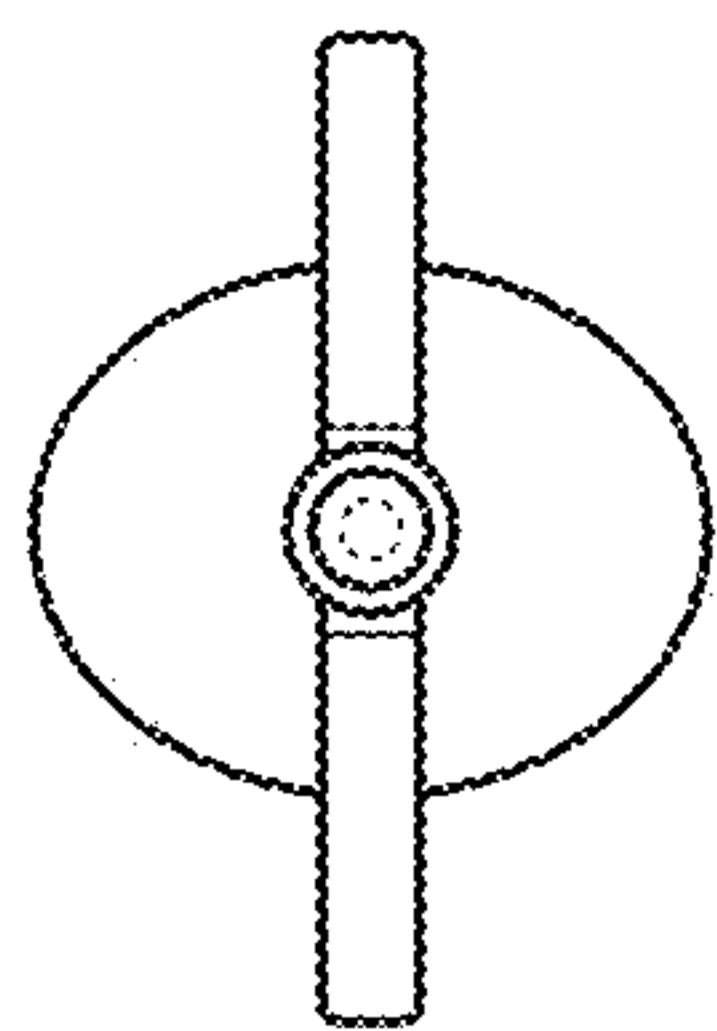

FIG. 14