



US00D918794S

(12) **United States Design Patent**
Choi et al.

(10) **Patent No.:** **US D918,794 S**

(45) **Date of Patent:** **** May 11, 2021**

(54) **VEHICLE REAR LOWER BUMPER**

(71) Applicant: **GM GLOBAL TECHNOLOGY OPERATIONS LLC**, Detroit, MI (US)

(72) Inventors: **Gapdong Choi**, Seoul (KR); **Gunjo Hwang**, Incheon (KR)

(73) Assignee: **GM GLOBAL TECHNOLOGY OPERATIONS LLC**, Detroit, MI (US)

(**) Term: **15 Years**

(21) Appl. No.: **29/708,150**

(22) Filed: **Oct. 3, 2019**

(30) **Foreign Application Priority Data**

Apr. 29, 2019 (KR) 30-2019-0020269
Apr. 29, 2019 (KR) 30-2019-0020298

(51) **LOC (13) Cl.** **12-16**

(52) **U.S. Cl.**
USPC **D12/169**

(58) **Field of Classification Search**
USPC D12/86, 90, 91, 92, 163, 169, 171, 196,
D12/216; D3/318
CPC B60R 19/02; B60R 19/04; B62D 25/00;
B62D 25/06; B62D 25/08; B62D 35/00
See application file for complete search history.

(56) **References Cited**

U.S. PATENT DOCUMENTS

D570,742 S 6/2008 Takagi et al.
D584,199 S * 1/2009 Leclercq D12/169
D592,105 S 5/2009 Dean et al.
D597,447 S 8/2009 Folden
D598,827 S * 8/2009 Kanai D12/169
D600,595 S 9/2009 Nakamura et al.
D601,925 S 10/2009 O'Donnell
D603,755 S 11/2009 Peters

D604,203 S 11/2009 O'Donnell
D605,082 S 12/2009 Munson
D605,083 S 12/2009 Manoogian, II et al.
D605,977 S 12/2009 Zipfel et al.
D605,978 S 12/2009 Wolff et al.
D608,249 S 1/2010 Peters
D608,690 S 1/2010 Folden et al.
D608,691 S 1/2010 Zak, Jr. et al.
D609,608 S 2/2010 Boniface et al.
D611,387 S 3/2010 Thompson et al.
D611,879 S 3/2010 Kim et al.
D612,297 S 3/2010 Peters et al.
D613,645 S 4/2010 Song et al.
D615,458 S 5/2010 Thompson et al.
D618,595 S 6/2010 Ware et al.
D623,090 S 9/2010 Cox et al.
D626,042 S * 10/2010 Yamazaki D12/169
D627,262 S 11/2010 Ikeda et al.
D635,488 S 4/2011 Phipps
D644,147 S 8/2011 Suh et al.
D644,567 S 9/2011 Kozub

(Continued)

Primary Examiner — Brett Miller
Assistant Examiner — Suzanne E Tisdell

(57) **CLAIM**

The ornamental design for a vehicle rear lower bumper, as shown and described.

DESCRIPTION

FIG. 1 is a front and left perspective view of a vehicle rear lower bumper showing our new design; FIG. 2 is a front elevation view thereof; FIG. 3 is a left elevation view thereof; FIG. 4 is a right elevation view thereof; FIG. 5 is a top view thereof; and, FIG. 6 is a bottom view thereof.

The broken lines in the drawings depict portions of the vehicle rear lower bumper that form no part of the claimed design.

1 Claim, 6 Drawing Sheets

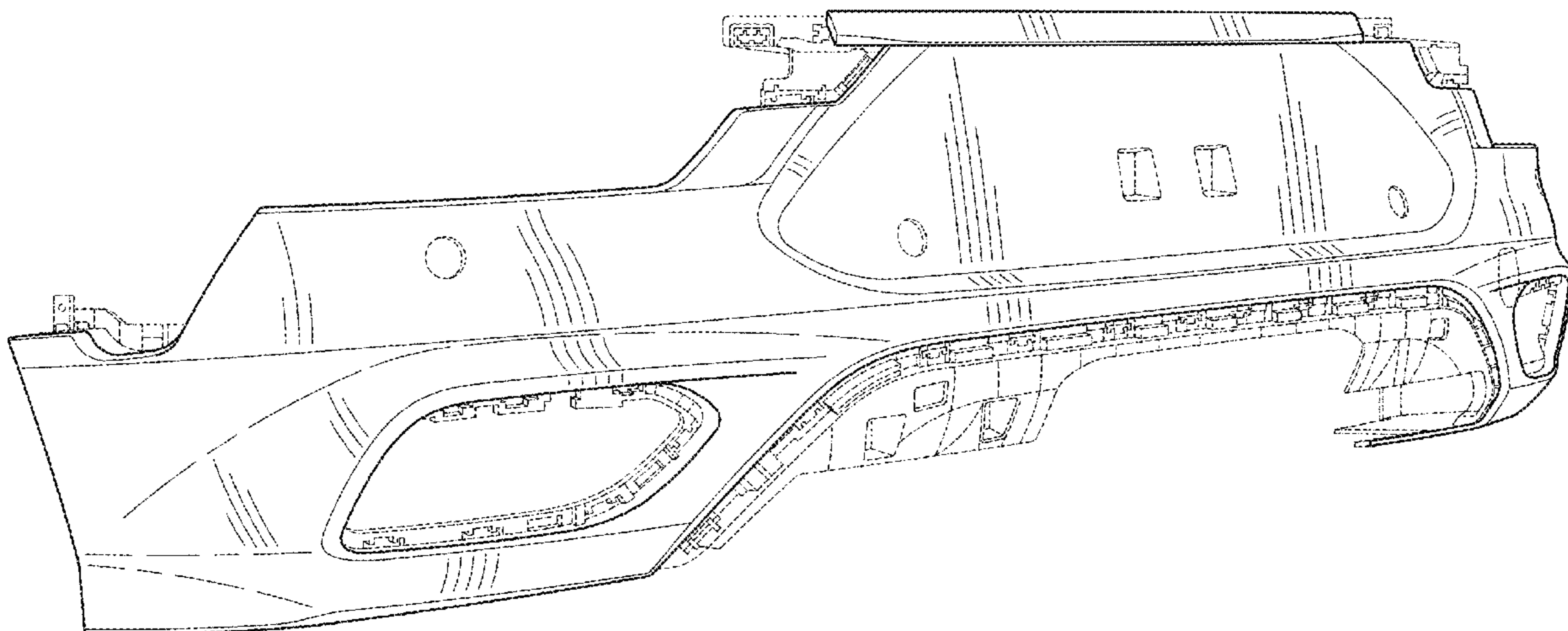

(56)

References Cited

U.S. PATENT DOCUMENTS

| | | | |
|------------|-----------|---------------------|---------|
| D657,718 S | 4/2012 | Zipfel et al. | |
| D659,052 S | 5/2012 | Ware et al. | |
| D659,053 S | 5/2012 | Ware et al. | |
| D668,182 S | 10/2012 | Barba Franco et al. | |
| D668,183 S | 10/2012 | Smart | |
| D678,820 S | 3/2013 | Son et al. | |
| D678,821 S | 3/2013 | Ikeda et al. | |
| D680,479 S | * 4/2013 | Frei | D12/169 |
| D680,909 S | 4/2013 | Munson et al. | |
| D680,910 S | 4/2013 | David | |
| D684,899 S | 6/2013 | Baker | |
| D686,536 S | 7/2013 | McCabe et al. | |
| D687,752 S | * 8/2013 | Fetherston | D12/169 |
| D688,989 S | * 9/2013 | Minamisawa | D12/169 |
| D692,798 S | 11/2013 | Thurber | |
| D692,799 S | 11/2013 | Smith et al. | |
| D696,157 S | 12/2013 | Loeb | |
| D699,629 S | 2/2014 | Ikeda et al. | |
| D700,871 S | 3/2014 | O'Donnell et al. | |
| D702,161 S | * 4/2014 | Hanaoka | D12/169 |
| D703,103 S | 4/2014 | Lee | |
| D704,103 S | 5/2014 | Mack et al. | |
| D705,132 S | 5/2014 | Ware et al. | |
| D705,699 S | 5/2014 | Ware et al. | |
| D712,322 S | * 9/2014 | Kobayashi | D12/169 |
| D713,298 S | 9/2014 | Dyson | |
| D713,764 S | 9/2014 | Ferlazzo et al. | |
| D716,696 S | 11/2014 | Thole et al. | |
| D716,706 S | 11/2014 | Thole et al. | |
| D716,709 S | 11/2014 | Thole et al. | |
| D717,696 S | 11/2014 | Thole et al. | |
| D718,189 S | 11/2014 | Krieg et al. | |
| D718,683 S | 12/2014 | Thole et al. | |
| D721,305 S | * 1/2015 | George | D12/169 |
| D721,306 S | * 1/2015 | George | D12/169 |
| D722,282 S | 2/2015 | Loeb | |
| D722,533 S | 2/2015 | Thole et al. | |
| D722,534 S | 2/2015 | Munson et al. | |
| D722,926 S | * 2/2015 | Kato | D12/169 |
| D723,435 S | * 3/2015 | Thole | D12/169 |
| D724,510 S | 3/2015 | McMahan et al. | |
| D725,001 S | 3/2015 | McMahan et al. | |
| D726,591 S | 4/2015 | Jacob | |
| D726,602 S | * 4/2015 | Rupar | D12/169 |
| D729,707 S | * 5/2015 | Thole | D12/169 |
| D730,776 S | 6/2015 | Smart | |
| D730,783 S | 6/2015 | Henriques et al. | |
| D732,427 S | 6/2015 | Loeb | |
| D732,429 S | 6/2015 | Loeb | |
| D732,430 S | 6/2015 | Loeb | |
| D732,431 S | 6/2015 | Loeb | |
| D732,432 S | 6/2015 | Aengenheyster | |
| D732,433 S | 6/2015 | Aengenheyster | |
| D732,435 S | 6/2015 | Mackay | |
| D733,002 S | 6/2015 | Loeb | |
| D735,611 S | 8/2015 | Aengenheyster | |
| D735,627 S | 8/2015 | Smith | |
| D736,451 S | 8/2015 | Smith | |
| D739,306 S | 9/2015 | McMahan et al. | |
| D739,317 S | 9/2015 | McMahan et al. | |
| D741,223 S | 10/2015 | Kim et al. | |
| D743,309 S | 11/2015 | Thole et al. | |
| D743,313 S | 11/2015 | Smith et al. | |
| D743,314 S | 11/2015 | Thole et al. | |
| D743,857 S | 11/2015 | McMahan et al. | |
| D744,158 S | 11/2015 | Willett et al. | |
| D745,086 S | 12/2015 | Finos et al. | |
| D745,719 S | 12/2015 | Boniface et al. | |
| D745,725 S | 12/2015 | McMahan et al. | |
| D745,726 S | 12/2015 | McMahan et al. | |
| D745,837 S | 12/2015 | Smith et al. | |
| D746,726 S | 1/2016 | Smith et al. | |
| D746,727 S | 1/2016 | Smith et al. | |
| D746,728 S | 1/2016 | Smith et al. | |
| D746,729 S | 1/2016 | Boniface et al. | |
| D746,730 S | 1/2016 | Kim et al. | |
| D747,514 S | 1/2016 | McMahan et al. | |
| D747,515 S | 1/2016 | McMahan et al. | |
| D747,819 S | 1/2016 | Thole et al. | |
| D749,021 S | 2/2016 | Boniface et al. | |
| D749,026 S | 2/2016 | Smith et al. | |
| D749,027 S | 2/2016 | McMahan et al. | |
| D749,246 S | 2/2016 | Thole et al. | |
| D749,249 S | 2/2016 | Thole et al. | |
| D749,250 S | 2/2016 | Thole et al. | |
| D749,985 S | 2/2016 | Kozub et al. | |
| D749,997 S | 2/2016 | McMahan et al. | |
| D750,001 S | 2/2016 | Thole et al. | |
| D753,032 S | 4/2016 | Smith et al. | |
| D753,033 S | 4/2016 | Thole et al. | |
| D753,034 S | 4/2016 | Thole et al. | |
| D753,035 S | 4/2016 | Boniface et al. | |
| D753,559 S | 4/2016 | McMahan et al. | |
| D753,560 S | 4/2016 | McMahan et al. | |
| D753,567 S | 4/2016 | Boniface et al. | |
| D754,571 S | 4/2016 | Boniface et al. | |
| D754,572 S | 4/2016 | McMahan et al. | |
| D755,088 S | 5/2016 | McMahan et al. | |
| D756,869 S | 5/2016 | McMahan et al. | |
| D758,271 S | 6/2016 | McMahan et al. | |
| D762,532 S | * 8/2016 | Tsutamori | D12/169 |
| D764,975 S | 8/2016 | Aengenheyster | |
| D764,976 S | 8/2016 | Aengenheyster | |
| D767,449 S | 9/2016 | Pevovar et al. | |
| D767,450 S | 9/2016 | Lee et al. | |
| D767,451 S | 9/2016 | Kozub et al. | |
| D767,454 S | 9/2016 | McMahan et al. | |
| D767,458 S | 9/2016 | Kim | |
| D767,459 S | 9/2016 | Kim | |
| D767,460 S | 9/2016 | Kozub et al. | |
| D767,461 S | 9/2016 | Kozub et al. | |
| D771,528 S | 11/2016 | Smith et al. | |
| D771,529 S | 11/2016 | Thole et al. | |
| D771,532 S | 11/2016 | Kapitonov | |
| D771,533 S | 11/2016 | Kapitonov | |
| D772,766 S | 11/2016 | Kozub et al. | |
| D772,767 S | 11/2016 | Kim | |
| D773,084 S | 11/2016 | Kapitonov | |
| D773,086 S | 11/2016 | McCabe et al. | |
| D774,226 S | 12/2016 | McCabe et al. | |
| D774,428 S | * 12/2016 | Davidson | D12/169 |
| D775,003 S | 12/2016 | Pevovar et al. | |
| D775,007 S | 12/2016 | Thole et al. | |
| D775,010 S | 12/2016 | Kim et al. | |
| D775,049 S | 12/2016 | Scheer et al. | |
| D775,549 S | 1/2017 | Karras | |
| D775,554 S | 1/2017 | Kapitonov | |
| D776,020 S | 1/2017 | Kapitonov | |
| D776,581 S | 1/2017 | Pevovar et al. | |
| D776,583 S | 1/2017 | Scheer et al. | |
| D776,841 S | 1/2017 | Kozub et al. | |
| D776,843 S | 1/2017 | McCabe et al. | |
| D776,846 S | 1/2017 | Willett et al. | |
| D777,359 S | 1/2017 | Kozub et al. | |
| D777,360 S | 1/2017 | Kozub et al. | |
| D777,361 S | 1/2017 | Kozub et al. | |
| D777,604 S | 1/2017 | McNerney | |
| D777,605 S | 1/2017 | Ferlazzo et al. | |
| D777,620 S | 1/2017 | Pevovar et al. | |
| D777,621 S | 1/2017 | Kim | |
| D777,622 S | 1/2017 | Kozub et al. | |
| D777,628 S | 1/2017 | Kozub et al. | |
| D777,955 S | 1/2017 | Willett et al. | |
| D778,212 S | 2/2017 | Kozub et al. | |
| D778,215 S | 2/2017 | Kozub et al. | |
| D780,064 S | 2/2017 | Smith et al. | |
| D780,067 S | 2/2017 | Zipfel et al. | |
| D780,068 S | 2/2017 | Whitla et al. | |
| D780,077 S | 2/2017 | Kim et al. | |
| D780,081 S | 2/2017 | Lee | |
| D780,084 S | 2/2017 | Scheer et al. | |
| D780,631 S | 3/2017 | Kozub et al. | |
| D780,644 S | 3/2017 | Kim et al. | |
| D781,184 S | 3/2017 | Thole et al. | |

(56)

References Cited

U.S. PATENT DOCUMENTS

| | | | |
|------------|-----------|------------------|---------|
| D781,192 S | 3/2017 | Kozub et al. | |
| D782,379 S | 3/2017 | Wassell | |
| D783,482 S | 4/2017 | Smith et al. | |
| D784,213 S | 4/2017 | Karras | |
| D784,223 S | 4/2017 | Lee | |
| D784,226 S | 4/2017 | Cheng | |
| D784,579 S | 4/2017 | Cheng et al. | |
| D784,877 S | 4/2017 | Lee | |
| D784,886 S | 4/2017 | Smith et al. | |
| D785,521 S | 5/2017 | Smith et al. | |
| D786,149 S | * 5/2017 | Pevovar | D12/169 |
| D786,743 S | 5/2017 | Smith et al. | |
| D786,750 S | 5/2017 | Lee | |
| D787,446 S | 5/2017 | Cockerill | |
| D787,984 S | 5/2017 | Fang | |
| D787,988 S | 5/2017 | Lee | |
| D787,989 S | 5/2017 | Kozub et al. | |
| D787,990 S | 5/2017 | Kozub et al. | |
| D787,992 S | 5/2017 | Lee | |
| D787,993 S | 5/2017 | McCabe et al. | |
| D788,001 S | 5/2017 | Lee | |
| D788,641 S | 6/2017 | Arnold | |
| D788,644 S | 6/2017 | Mueller | |
| D788,645 S | 6/2017 | Mueller | |
| D788,657 S | * 6/2017 | Oohashi | D12/169 |
| D789,250 S | 6/2017 | Arnold | |
| D789,260 S | 6/2017 | Smith | |
| D789,575 S | 6/2017 | Willett | |
| D789,841 S | 6/2017 | Lee | |
| D789,849 S | 6/2017 | Lee | |
| D791,018 S | 7/2017 | Mylenek | |
| D791,644 S | 7/2017 | Fang | |
| D792,290 S | 7/2017 | Smith et al. | |
| D792,293 S | 7/2017 | McCabe et al. | |
| D792,294 S | 7/2017 | McCabe et al. | |
| D792,295 S | 7/2017 | McCabe et al. | |
| D792,815 S | * 7/2017 | Kozub | D12/169 |
| D792,816 S | * 7/2017 | Kozub | D12/169 |
| D793,290 S | 8/2017 | Kozub | |
| D793,292 S | 8/2017 | Lee | |
| D793,293 S | 8/2017 | Lee et al. | |
| D793,294 S | 8/2017 | Lee | |
| D793,295 S | 8/2017 | McCabe et al. | |
| D793,296 S | * 8/2017 | Smith | D12/169 |
| D793,297 S | 8/2017 | Smith et al. | |
| D793,299 S | 8/2017 | Krieg et al. | |
| D793,300 S | 8/2017 | Krieg et al. | |
| D793,301 S | 8/2017 | Kozub | |
| D793,302 S | 8/2017 | Kozub | |
| D793,311 S | 8/2017 | Whitla et al. | |
| D793,590 S | 8/2017 | Kozub et al. | |
| D793,591 S | 8/2017 | Kozub et al. | |
| D793,917 S | 8/2017 | Kozub | |
| D793,918 S | 8/2017 | Kozub | |
| D793,921 S | * 8/2017 | Takamatsu | D12/169 |
| D793,924 S | * 8/2017 | Sagawa | D12/169 |
| D794,229 S | 8/2017 | Barry | |
| D794,230 S | 8/2017 | Kozub | |
| D795,747 S | 8/2017 | Bailie | |
| D795,757 S | 8/2017 | Pevovar et al. | |
| D795,758 S | 8/2017 | Karras | |
| D795,759 S | 8/2017 | Kozub et al. | |
| D795,760 S | 8/2017 | Kozub et al. | |
| D795,762 S | 8/2017 | Lee | |
| D795,763 S | 8/2017 | Kozub | |
| D796,088 S | 8/2017 | McCabe et al. | |
| D796,093 S | 8/2017 | Mainville | |
| D796,390 S | 9/2017 | Pevovar et al. | |
| D797,019 S | * 9/2017 | Yamashita | D12/169 |
| D797,537 S | 9/2017 | Cooper et al. | |
| D797,603 S | 9/2017 | Noone et al. | |
| D797,614 S | 9/2017 | Lee | |
| D797,616 S | 9/2017 | Lee | |
| D797,617 S | * 9/2017 | Mori | D12/169 |
| D797,618 S | * 9/2017 | Suzuki | D12/169 |
| D797,624 S | 9/2017 | Nakamura | |
| D797,625 S | 9/2017 | Perkins | |
| D797,631 S | 9/2017 | Pevovar et al. | |
| D797,632 S | 9/2017 | Zipfel et al. | |
| D797,967 S | 9/2017 | Barry | |
| D797,970 S | 9/2017 | Mainville | |
| D797,971 S | 9/2017 | Mainville | |
| D797,972 S | 9/2017 | Whitla et al. | |
| D798,204 S | 9/2017 | Mainville | |
| D799,384 S | 10/2017 | Kozub et al. | |
| D799,385 S | 10/2017 | Kozub et al. | |
| D799,386 S | 10/2017 | Kozub et al. | |
| D799,728 S | 10/2017 | Whitla et al. | |
| D800,035 S | * 10/2017 | Takamatsu | D12/169 |
| D800,614 S | * 10/2017 | Park | D12/169 |
| D801,236 S | 10/2017 | Kozub et al. | |
| D801,577 S | 10/2017 | Ruiz | |
| D801,882 S | 11/2017 | Kozub et al. | |
| D802,205 S | 11/2017 | Ruiz | |
| D802,478 S | 11/2017 | Perkins | |
| D802,491 S | 11/2017 | Mainville | |
| D802,496 S | 11/2017 | Mainville | |
| D802,502 S | 11/2017 | McMahan | |
| D803,112 S | * 11/2017 | Tomita | D12/169 |
| D803,727 S | 11/2017 | Noone et al. | |
| D803,731 S | 11/2017 | Zipfel | |
| D804,370 S | 12/2017 | Kozub et al. | |
| D804,371 S | 12/2017 | Whitla et al. | |
| D804,372 S | 12/2017 | Kozub | |
| D804,378 S | 12/2017 | Perkins | |
| D804,379 S | 12/2017 | McMahan | |
| D805,006 S | 12/2017 | Nakamura | |
| D805,013 S | 12/2017 | Whitla | |
| D805,014 S | 12/2017 | Zipfel | |
| D805,441 S | 12/2017 | Karras | |
| D805,449 S | * 12/2017 | Chung | D12/169 |
| D805,964 S | 12/2017 | Whitla | |
| D805,965 S | 12/2017 | Davis | |
| D805,966 S | 12/2017 | Perkins | |
| D805,985 S | 12/2017 | Nakamura | |
| D807,232 S | 1/2018 | Bailie | |
| D807,239 S | 1/2018 | Perkins | |
| D807,240 S | 1/2018 | Perkins | |
| D807,241 S | 1/2018 | Perkins | |
| D807,248 S | * 1/2018 | Piscitelli | D12/169 |
| D807,250 S | * 1/2018 | Piscitelli | D12/169 |
| D807,252 S | * 1/2018 | Piscitelli | D12/169 |
| D807,254 S | * 1/2018 | Piscitelli | D12/169 |
| D807,257 S | * 1/2018 | Piscitelli | D12/169 |
| D807,258 S | * 1/2018 | Patel | D12/169 |
| D809,442 S | 2/2018 | Zipfel et al. | |
| D811,269 S | 2/2018 | Thompson et al. | |
| D811,942 S | 3/2018 | Jacob | |
| D811,957 S | 3/2018 | Whitla et al. | |
| D811,958 S | 3/2018 | Zipfel et al. | |
| D811,959 S | 3/2018 | Perkins | |
| D811,960 S | 3/2018 | Nakamura | |
| D811,961 S | 3/2018 | Sullivan | |
| D811,962 S | 3/2018 | Sullivan | |
| D811,963 S | 3/2018 | Sullivan | |
| D811,964 S | 3/2018 | Perkins | |
| D811,965 S | 3/2018 | Moffett et al. | |
| D812,525 S | 3/2018 | Lee | |
| D812,526 S | 3/2018 | Zipfel et al. | |
| D812,527 S | 3/2018 | Perkins | |
| D812,528 S | 3/2018 | Nakamura | |
| D813,098 S | 3/2018 | Thompson et al. | |
| D813,109 S | 3/2018 | Zipfel et al. | |
| D813,110 S | 3/2018 | Whitla et al. | |
| D813,111 S | 3/2018 | Sullivan | |
| D813,116 S | 3/2018 | Park | |
| D813,117 S | 3/2018 | Sullivan | |
| D813,121 S | 3/2018 | Swanseger | |
| D813,730 S | 3/2018 | Zipfel et al. | |
| D813,731 S | 3/2018 | McMahan | |
| D813,732 S | 3/2018 | Whitla et al. | |
| D813,733 S | 3/2018 | Lee | |
| D813,734 S | 3/2018 | Nakamura | |
| D813,740 S | 3/2018 | Park | |

(56)

References Cited

U.S. PATENT DOCUMENTS

| | | | | | |
|------------|--------|-----------------|------------|---------|------------------|
| D813,741 S | 3/2018 | Perkins | D829,622 S | 10/2018 | Jacob |
| D813,742 S | 3/2018 | McMahan et al. | D830,241 S | 10/2018 | Kozub |
| D813,743 S | 3/2018 | Lee | D830,242 S | 10/2018 | Zipfel |
| D813,744 S | 3/2018 | Whitla et al. | D830,252 S | 10/2018 | Swanseger |
| D813,748 S | 3/2018 | Kim | D830,258 S | 10/2018 | Moffett et al. |
| D813,753 S | 3/2018 | Loeb | D830,261 S | 10/2018 | Jacob |
| D813,754 S | 3/2018 | Loeb | D830,589 S | 10/2018 | Henriques |
| D813,755 S | 3/2018 | Loeb | D832,752 S | 11/2018 | Lee |
| D813,756 S | 3/2018 | Loeb | D835,003 S | 12/2018 | Thompson et al. |
| D813,757 S | 3/2018 | Kozub | D835,012 S | 12/2018 | Smith et al. |
| D813,758 S | 3/2018 | Gonzales | D837,105 S | 1/2019 | Loeb |
| D813,759 S | 3/2018 | Perkins | D837,109 S | 1/2019 | Kozub et al. |
| D814,369 S | 4/2018 | Loeb | D837,424 S | 1/2019 | Whitla et al. |
| D814,982 S | 4/2018 | Whitla et al. | D838,015 S | 1/2019 | McMahan et al. |
| D814,983 S | 4/2018 | Whitla et al. | D838,016 S | 1/2019 | McMahan et al. |
| D815,570 S | 4/2018 | McMahan et al. | D838,390 S | 1/2019 | McMahan et al. |
| D815,572 S | 4/2018 | Perkins | D838,391 S | 1/2019 | McMahan et al. |
| D815,573 S | 4/2018 | Whitla et al. | D839,157 S | 1/2019 | Smith et al. |
| D815,574 S | 4/2018 | Mainville | D839,163 S | 1/2019 | Pinazzo et al. |
| D815,985 S | 4/2018 | Mueller | D839,164 S | 1/2019 | Zipfel |
| D815,993 S | 4/2018 | Kozub et al. | D839,460 S | 1/2019 | Zipfel et al. |
| D815,994 S | 4/2018 | Nakamura | D840,068 S | 2/2019 | Zipfel et al. |
| D816,003 S | 4/2018 | Perkins | D840,069 S | 2/2019 | Perkins |
| D816,558 S | 5/2018 | McMahan et al. | D840,285 S | 2/2019 | Mack et al. |
| D816,559 S | 5/2018 | McMahan et al. | D840,286 S | 2/2019 | Mack et al. |
| D816,561 S | 5/2018 | McMahan | D840,293 S | 2/2019 | Koo et al. |
| D816,562 S | 5/2018 | Whitla et al. | D840,302 S | 2/2019 | O'Donnell et al. |
| D816,563 S | 5/2018 | McMahan et al. | D840,303 S | 2/2019 | Park Cheng |
| D816,564 S | 5/2018 | Kim | D840,306 S | 2/2019 | Kozub |
| D816,565 S | 5/2018 | Kim | D840,565 S | 2/2019 | Whitla et al. |
| D816,566 S | 5/2018 | Loeb | D840,570 S | 2/2019 | Kim et al. |
| D817,836 S | 5/2018 | McMahan et al. | D840,571 S | 2/2019 | Zipfel et al. |
| D818,156 S | 5/2018 | Kim et al. | D840,572 S | 2/2019 | Perkins |
| D818,157 S | 5/2018 | Zipfel et al. | D840,885 S | 2/2019 | Park Cheng |
| D818,158 S | 5/2018 | Zipfel et al. | D841,527 S | 2/2019 | Kozub et al. |
| D818,159 S | 5/2018 | Zipfel et al. | D841,532 S | 2/2019 | Koo et al. |
| D818,160 S | 5/2018 | Perkins | D841,540 S | 2/2019 | Koo et al. |
| D818,406 S | 5/2018 | McMahan et al. | D841,541 S | 2/2019 | Krieg |
| D818,876 S | 5/2018 | Whitla et al. | D841,542 S | 2/2019 | Koo et al. |
| D818,877 S | 5/2018 | Nakamura et al. | D841,547 S | 2/2019 | Zipfel et al. |
| D818,878 S | 5/2018 | McMahan et al. | D841,843 S | 2/2019 | Park |
| D818,892 S | 5/2018 | Lee | D841,844 S | 2/2019 | Perkins |
| D818,893 S | 5/2018 | Kim | D841,845 S | 2/2019 | Park |
| D818,903 S | 5/2018 | Zipfel et al. | D842,178 S | 3/2019 | Pinazzo et al. |
| D818,906 S | 5/2018 | McMahan | D842,306 S | 3/2019 | Lindo et al. |
| D818,907 S | 5/2018 | Whitla et al. | D843,023 S | 3/2019 | Whitla et al. |
| D818,915 S | 5/2018 | Kozub et al. | D843,024 S | 3/2019 | Hochmuth |
| D818,922 S | 5/2018 | Whitla et al. | D843,025 S | 3/2019 | Smith et al. |
| D819,505 S | 6/2018 | McMahan et al. | D843,275 S | 3/2019 | Koo et al. |
| D819,519 S | 6/2018 | Whitla et al. | D843,280 S | 3/2019 | Thurber et al. |
| D821,617 S | 6/2018 | Perkins | D843,614 S | 3/2019 | Whitla et al. |
| D822,550 S | 7/2018 | Wassell et al. | D843,616 S | 3/2019 | Smith et al. |
| D822,551 S | 7/2018 | McMahan et al. | D843,617 S | 3/2019 | Smith et al. |
| D823,188 S | 7/2018 | Loeb | D843,891 S | 3/2019 | Thompson et al. |
| D823,738 S | 7/2018 | Kim | D843,904 S | 3/2019 | Kim |
| D823,741 S | 7/2018 | Kim | D844,184 S | 3/2019 | Whitla et al. |
| D823,762 S | 7/2018 | Loeb | D844,185 S | 3/2019 | Hochmuth |
| D823,763 S | 7/2018 | Koo et al. | D844,186 S | 3/2019 | Smith et al. |
| D824,811 S | 8/2018 | Mainville | D845,184 S | 4/2019 | Zipfel |
| D824,812 S | 8/2018 | Loeb | D845,186 S | 4/2019 | Koo et al. |
| D824,824 S | 8/2018 | Kim | D845,187 S | 4/2019 | Pinazzo et al. |
| D824,825 S | 8/2018 | Loeb | D845,188 S | 4/2019 | Pinazzo et al. |
| D825,083 S | 8/2018 | Perkins | D845,189 S | 4/2019 | Pinazzo et al. |
| D825,388 S | 8/2018 | Karras et al. | D845,190 S | 4/2019 | Zipfel |
| D825,403 S | 8/2018 | Whitla et al. | D845,196 S | 4/2019 | Kozub |
| D826,114 S | 8/2018 | Smith et al. | D845,518 S | 4/2019 | Kozub |
| D826,435 S | 8/2018 | Kim | D845,519 S | 4/2019 | Zipfel |
| D826,803 S | 8/2018 | Smith et al. | D846,448 S | 4/2019 | Loeb |
| D827,506 S | 9/2018 | McMahan et al. | D846,457 S | 4/2019 | Koo et al. |
| D827,508 S | 9/2018 | Whitla et al. | D846,458 S | 4/2019 | Mack et al. |
| D827,510 S | 9/2018 | Kim | D846,769 S | 4/2019 | Koo et al. |
| D827,527 S | 9/2018 | Loeb | D846,770 S | 4/2019 | Kozub |
| D828,246 S | 9/2018 | Loeb | D846,771 S | 4/2019 | Zipfel |
| D828,261 S | 9/2018 | Moffett et al. | D846,772 S | 4/2019 | Pinazzo et al. |
| D828,935 S | 9/2018 | Hochmuth | D847,027 S | 4/2019 | Loeb |
| | | | D847,028 S | 4/2019 | Loeb |
| | | | D847,038 S | 4/2019 | Loeb |
| | | | D847,041 S | 4/2019 | Blanski et al. |
| | | | D847,042 S | 4/2019 | Pinazzo et al. |

(56)

References Cited

U.S. PATENT DOCUMENTS

| | | | | | |
|------------|--------|-------------------|-------------------|---------|-----------------------------|
| D847,043 S | 4/2019 | Kozub | D855,515 S | 8/2019 | Riggs et al. |
| D847,044 S | 4/2019 | Zipfel | D855,518 S | 8/2019 | Whitla et al. |
| D847,045 S | 4/2019 | Whitla et al. | D855,520 S | 8/2019 | Parkinson |
| D847,046 S | 4/2019 | Whitla et al. | D855,523 S | 8/2019 | Perkins |
| D847,047 S | 4/2019 | Krieg et al. | D855,524 S | 8/2019 | Lee |
| D847,390 S | 4/2019 | Koo et al. | D856,201 S | 8/2019 | Blanski et al. |
| D847,391 S | 4/2019 | Pinazzo et al. | D856,204 S | 8/2019 | Kapitonov |
| D847,392 S | 4/2019 | Zipfel | D856,206 S | 8/2019 | De Leon |
| D847,699 S | 5/2019 | Kozub | D856,242 S | 8/2019 | Blanski et al. |
| D847,700 S | 5/2019 | Kozub | D856,864 S | 8/2019 | Kapitonov |
| D847,701 S | 5/2019 | Kozub | D856,874 S | 8/2019 | Kozub |
| D847,702 S | 5/2019 | Zipfel | D856,875 S | 8/2019 | Kozub |
| D847,703 S | 5/2019 | Kozub | D856,876 S | 8/2019 | Kapitonov |
| D847,704 S | 5/2019 | Zipfel | D857,260 S | 8/2019 | Kil et al. |
| D847,705 S | 5/2019 | Zipfel | D857,567 S | 8/2019 | Blanski et al. |
| D847,707 S | 5/2019 | Park Cheng et al. | D857,936 S | 8/2019 | Kil et al. |
| D847,714 S | 5/2019 | Mack et al. | D857,938 S | 8/2019 | Blanski et al. |
| D848,315 S | 5/2019 | Koo et al. | D857,939 S | 8/2019 | Kozub |
| D848,318 S | 5/2019 | McMahan et al. | D857,940 S | 8/2019 | Park |
| D848,320 S | 5/2019 | Pinazzo et al. | D857,941 S | 8/2019 | Whitla et al. |
| D848,322 S | 5/2019 | Mack et al. | D857,942 S | 8/2019 | Perkins |
| D848,323 S | 5/2019 | Mack et al. | D857,943 S | 8/2019 | Hochmuth |
| D848,324 S | 5/2019 | Thurber et al. | D857,944 S | 8/2019 | Pinazzo et al. |
| D848,325 S | 5/2019 | Thurber et al. | D857,945 S | 8/2019 | Smith et al. |
| D848,647 S | 5/2019 | Kozub | D857,946 S | 8/2019 | Smith et al. |
| D848,908 S | 5/2019 | Krieg | D857,947 S | 8/2019 | Koo et al. |
| D848,909 S | 5/2019 | Lee | D857,948 S | 8/2019 | Koo et al. |
| D848,911 S | 5/2019 | De Leon | D857,949 S | 8/2019 | Smith et al. |
| D848,915 S | 5/2019 | Izard | D857,950 S | 8/2019 | Zipfel |
| D849,627 S | 5/2019 | Zipfel | D857,951 S | 8/2019 | Whitla et al. |
| D849,629 S | 5/2019 | De Leon | D857,952 S | 8/2019 | Smith et al. |
| D849,630 S | 5/2019 | De Leon | D858,373 S | 9/2019 | Blanski et al. |
| D850,341 S | 6/2019 | Riggs et al. | D858,377 S | 9/2019 | Riggs et al. |
| D850,989 S | 6/2019 | Kozub | D858,813 S | 9/2019 | Datta |
| D851,002 S | 6/2019 | Kozub | D858,814 S | 9/2019 | Burns |
| D851,541 S | 6/2019 | Pinazzo | D858,817 S | 9/2019 | Henriques |
| D851,542 S | 6/2019 | Mack | D858,818 S | 9/2019 | McMahan et al. |
| D851,547 S | 6/2019 | Mack et al. | D858,819 S | 9/2019 | McMahan et al. |
| D851,548 S | 6/2019 | Mack et al. | D858,820 S | 9/2019 | McMahan et al. |
| D851,549 S | 6/2019 | Mack et al. | D858,821 S | 9/2019 | Park |
| D851,550 S | 6/2019 | Mack et al. | D858,822 S | 9/2019 | Whitla et al. |
| D851,551 S | 6/2019 | Mack et al. | D858,823 S | 9/2019 | Zipfel |
| D851,552 S | 6/2019 | Mack et al. | D858,824 S | 9/2019 | Pinazzo et al. |
| D851,555 S | 6/2019 | Whitla et al. | D859,229 S | 9/2019 | Karras et al. |
| D851,556 S | 6/2019 | Thurber et al. | D859,230 S | 9/2019 | Parkinson et al. |
| D851,557 S | 6/2019 | Thurber et al. | D859,231 S | 9/2019 | Wilkins et al. |
| D851,558 S | 6/2019 | Thurber et al. | D859,232 S | 9/2019 | Izard et al. |
| D851,559 S | 6/2019 | Thurber et al. | D859,233 S | 9/2019 | Izard et al. |
| D851,560 S | 6/2019 | Yong et al. | D859,237 S | 9/2019 | Koo et al. |
| D851,561 S | 6/2019 | Yong et al. | D859,238 S | 9/2019 | Smith et al. |
| D852,093 S | 6/2019 | Kozub | D859,239 S | 9/2019 | Sullivan et al. |
| D852,094 S | 6/2019 | Zipfel | D859,246 S | 9/2019 | Thurber et al. |
| D852,096 S | 6/2019 | Kozub | D859,248 S | 9/2019 | Wilkins et al. |
| D852,099 S | 6/2019 | Loeb | D859,252 S | 9/2019 | Krieg |
| D852,389 S | 6/2019 | Koo et al. | D859,253 S | 9/2019 | Izard |
| D852,393 S | 6/2019 | Whitla et al. | D859,254 S | 9/2019 | Izard |
| D853,903 S | 7/2019 | Loeb | D859,707 S | 9/2019 | McMahan et al. |
| D853,904 S | 7/2019 | Koo et al. | D859,708 S | 9/2019 | Kozub |
| D853,924 S | 7/2019 | Riggs et al. | D859,709 S | 9/2019 | Zipfel |
| D854,462 S | 7/2019 | Lee | D860,075 S | 9/2019 | Riggs et al. |
| D854,471 S | 7/2019 | Lee | D860,076 S | 9/2019 | Bartels et al. |
| D854,977 S | 7/2019 | Parkinson et al. | D860,077 S | 9/2019 | Riggs et al. |
| D854,979 S | 7/2019 | Krieg et al. | D860,078 S | 9/2019 | O'Donnell et al. |
| D854,988 S | 7/2019 | Krieg | D860,079 S | 9/2019 | Sullivan et al. |
| D854,991 S | 7/2019 | Whitla et al. | D860,085 S | 9/2019 | Koo et al. |
| D855,503 S | 8/2019 | Blanski et al. | D860,489 S | 9/2019 | Henriques |
| D855,504 S | 8/2019 | Lee | D860,490 S | 9/2019 | Henriques |
| D855,505 S | 8/2019 | Thurber et al. | 2004/0032133 A1 * | 2/2004 | Bird B60R 19/14 |
| D855,507 S | 8/2019 | Blanski et al. | 2006/0249961 A1 * | 11/2006 | Flotzinger B60R 19/04 |
| D855,508 S | 8/2019 | Wilkins et al. | 2006/0290169 A1 * | 12/2006 | Fukushima B62D 35/00 |
| D855,509 S | 8/2019 | Wilkins | | | 296/180.1 |

* cited by examiner

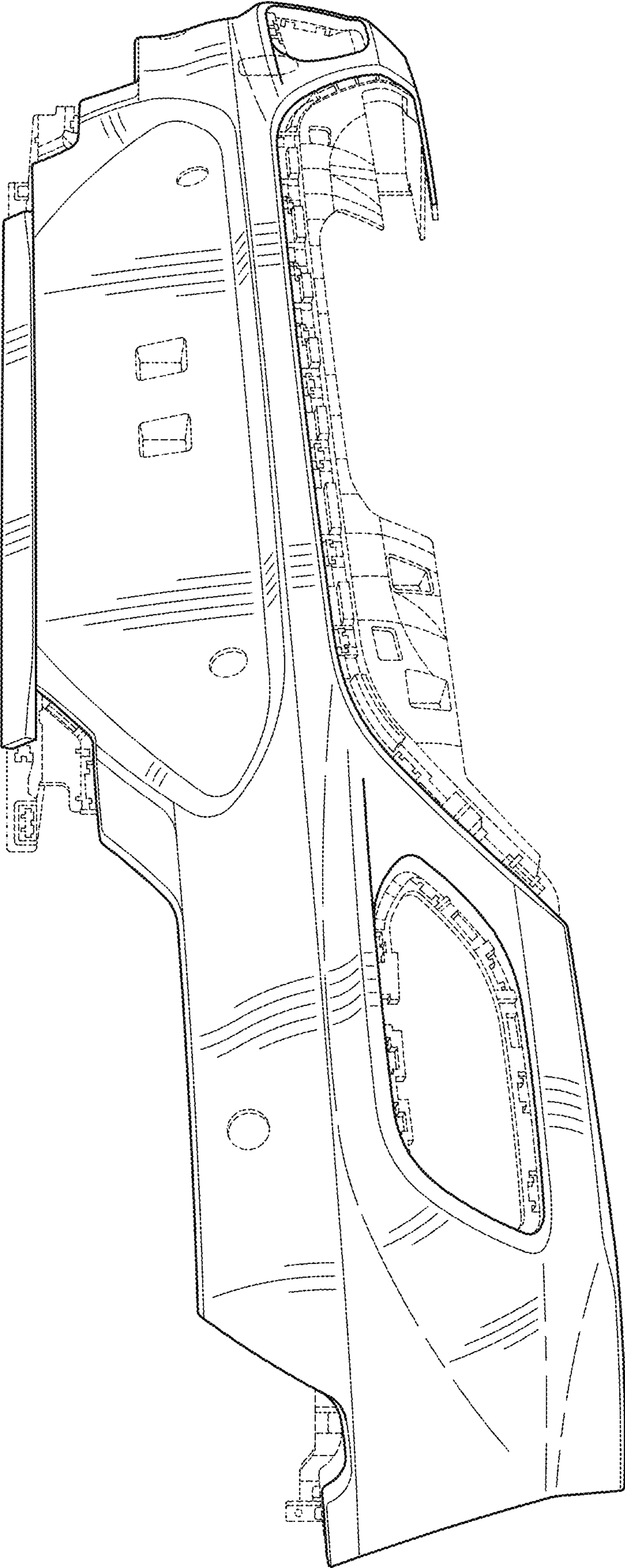

FIG. 1

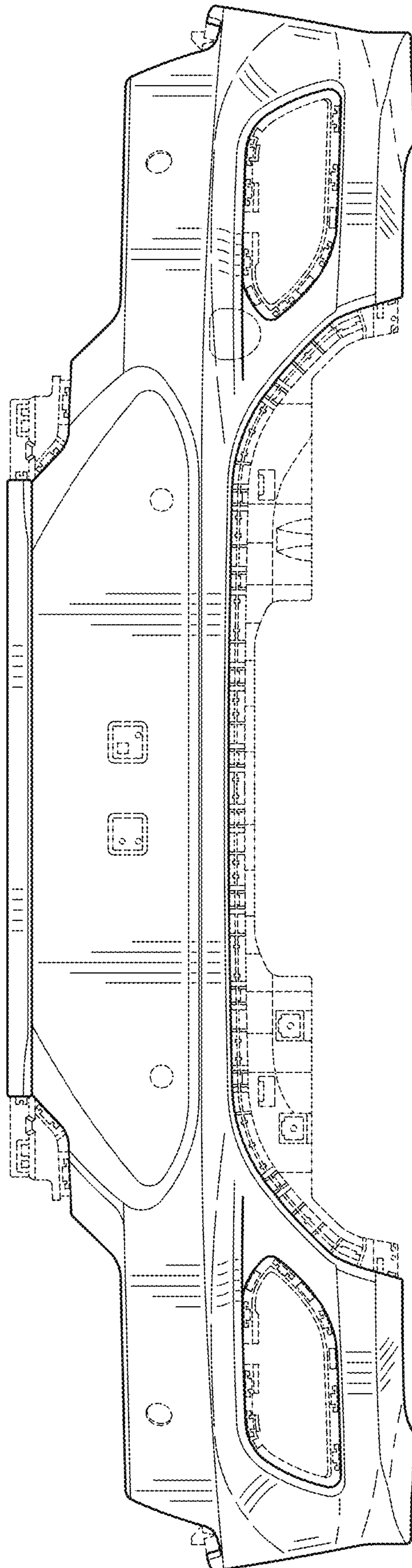

FIG. 2

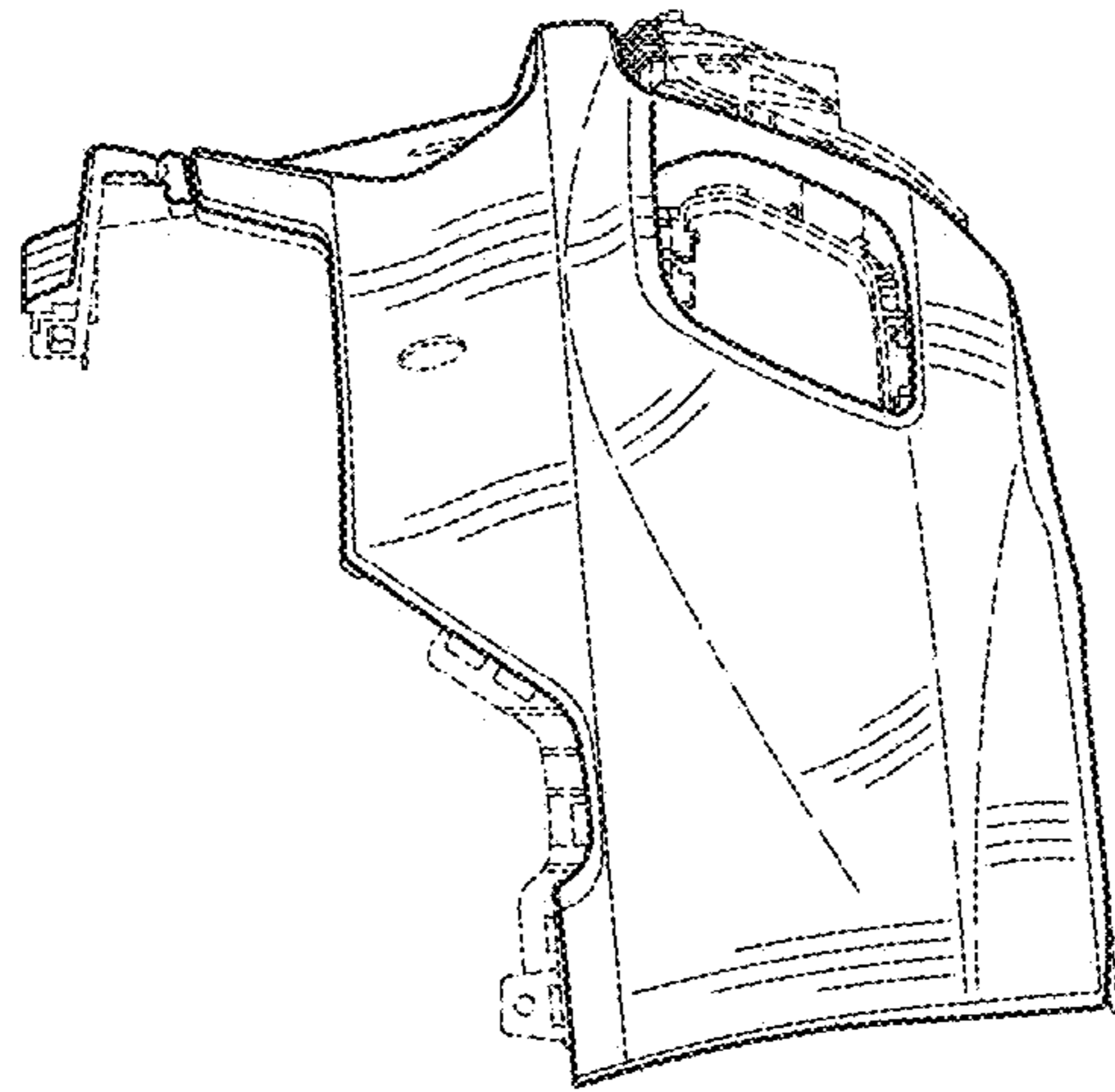

FIG. 3

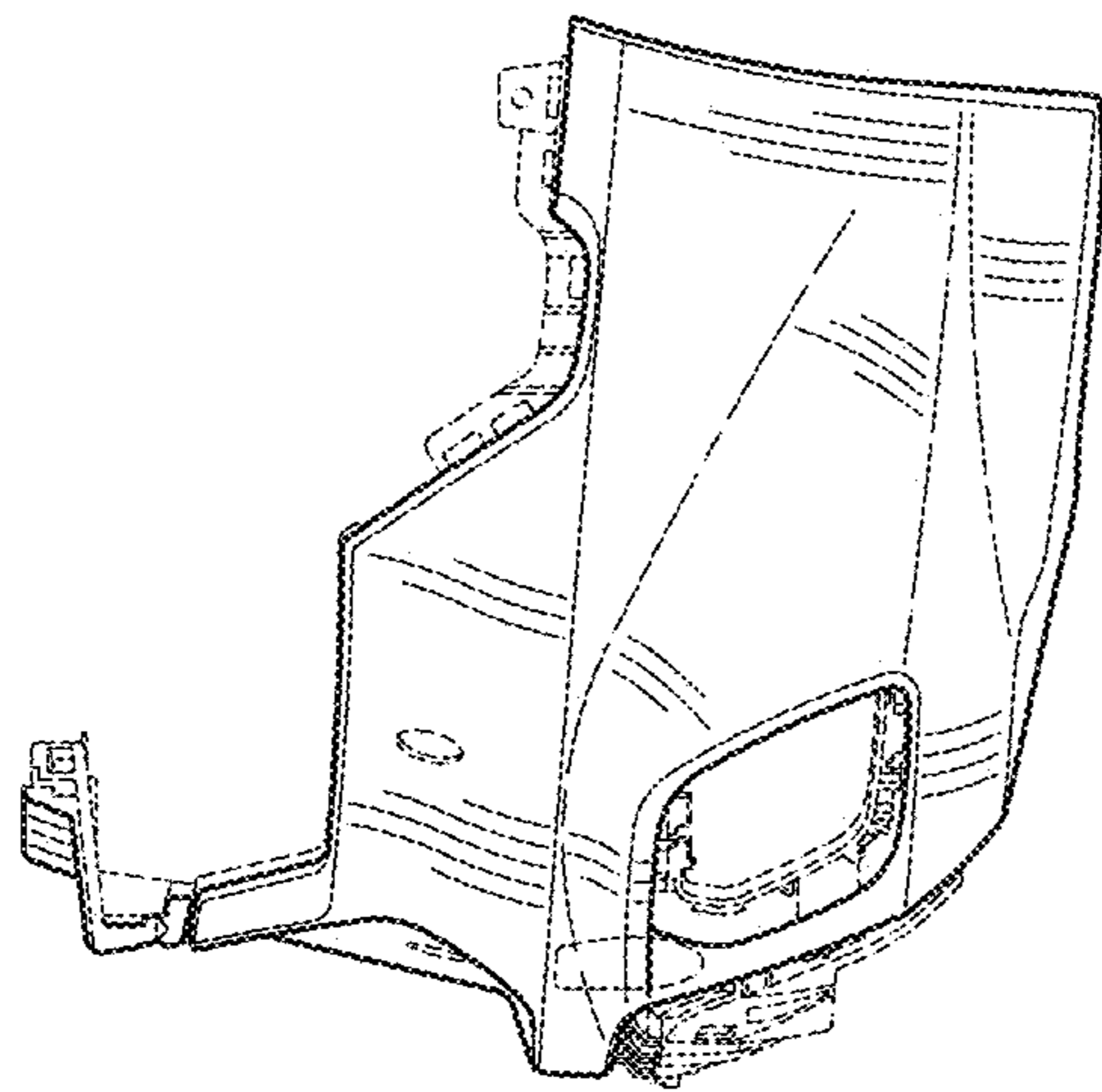

FIG. 4

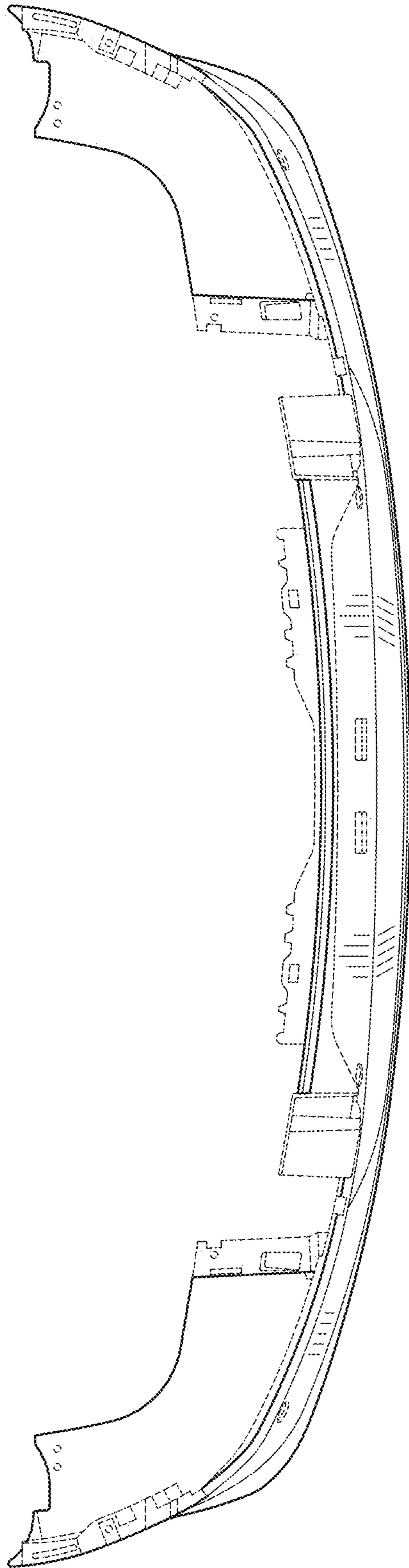

FIG. 5

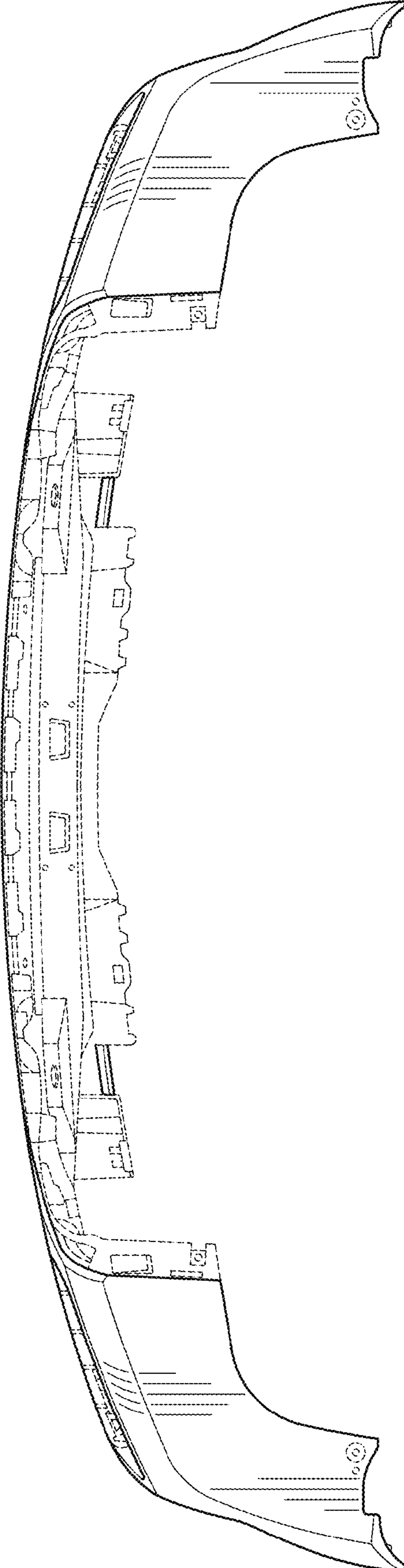

FIG. 6