



US00D918767S

(12) **United States Design Patent** (10) **Patent No.:** **US D918,767 S**
Newell (45) **Date of Patent:** **** May 11, 2021**

(54) **JEWELRY ARTICLE**

(71) Applicant: **Courtney Newell**, Dallas, TX (US)

(72) Inventor: **Courtney Newell**, Dallas, TX (US)

(**) Term: **15 Years**

(21) Appl. No.: **29/646,940**

(22) Filed: **May 8, 2018**

(51) **LOC (13) Cl.** **11-01**

(52) **U.S. Cl.**
USPC **D11/79**

(58) **Field of Classification Search**
USPC ... D11/1, 4, 3, 6, 13-18, 86, 93, 94, 128, 2,
D11/7, 8-12, 26-30, 40-47, 56, 78.1,
D11/79-83, 103; D21/390, 386; D1/100,
D1/126, 127, 130; D26/85
CPC ... A44C 15/005; A44C 15/0025; A44C 13/00;
A44C 1/00
See application file for complete search history.

(56) **References Cited**

U.S. PATENT DOCUMENTS

421,022	A *	2/1890	Adams	A44C 1/00 63/20
D23,096	S *	3/1894	Harsh	D1/127
D305,512	S *	1/1990	Bulgari	D11/86
D365,849	S *	1/1996	Greer, Jr.	D19/117
D457,086	S *	5/2002	Torres	D11/3
D457,087	S *	5/2002	Torres	D11/4
D457,088	S *	5/2002	Torres	D11/4
D468,658	S *	1/2003	Torres	D11/26
D470,430	S *	2/2003	Torres	D11/4
D606,232	S *	12/2009	Sabernig	D26/85
D814,333	S *	4/2018	Penna	D11/79

(Continued)

OTHER PUBLICATIONS

Etsy Brass Semicircle Blank, no date available, [online], [site visited May 27, 2020]. Retrieved from url:https://www.etsy.com/listing/724042738/brass-semicircle-blank-raw-brass (Year: 2020).*

(Continued)

Primary Examiner — Wendy L Arminio

Assistant Examiner — Tracey J Bell

(74) *Attorney, Agent, or Firm* — Polsinelli PC; Adam C. Rehm

(57) **CLAIM**

The ornamental design for a jewelry article, as shown and described.

DESCRIPTION

FIG. 1 is a front, top side perspective view of a jewelry article according to an embodiment of the new design; FIG. 2 is a front side elevation view thereof; FIG. 3 is a rear side elevation view thereof; FIG. 4 is a right side elevation view thereof; FIG. 5 is a left side elevation view thereof; FIG. 6 is a top plan view thereof; FIG. 7 is a bottom plan view thereof; FIG. 8 is a front, top side perspective view of a jewelry article according to another embodiment of the new design; FIG. 9 is a front side elevation view thereof; FIG. 10 is a rear side elevation view thereof; FIG. 11 is a right side elevation view thereof; FIG. 12 is a left side elevation view thereof; FIG. 13 is a top plan view thereof; and, FIG. 14 is a bottom plan view thereof.

The broken lines shown in the drawings show portions of the jewelry article that form no part of the claimed design. The dot-dash lines in the drawings and the broken lines that are immediately adjacent to shaded areas and define unshaded areas in the drawings represent the bounds of the claimed design. The shade lines in the drawings show contour and do not claim surface ornamentation or treatment.

1 Claim, 10 Drawing Sheets

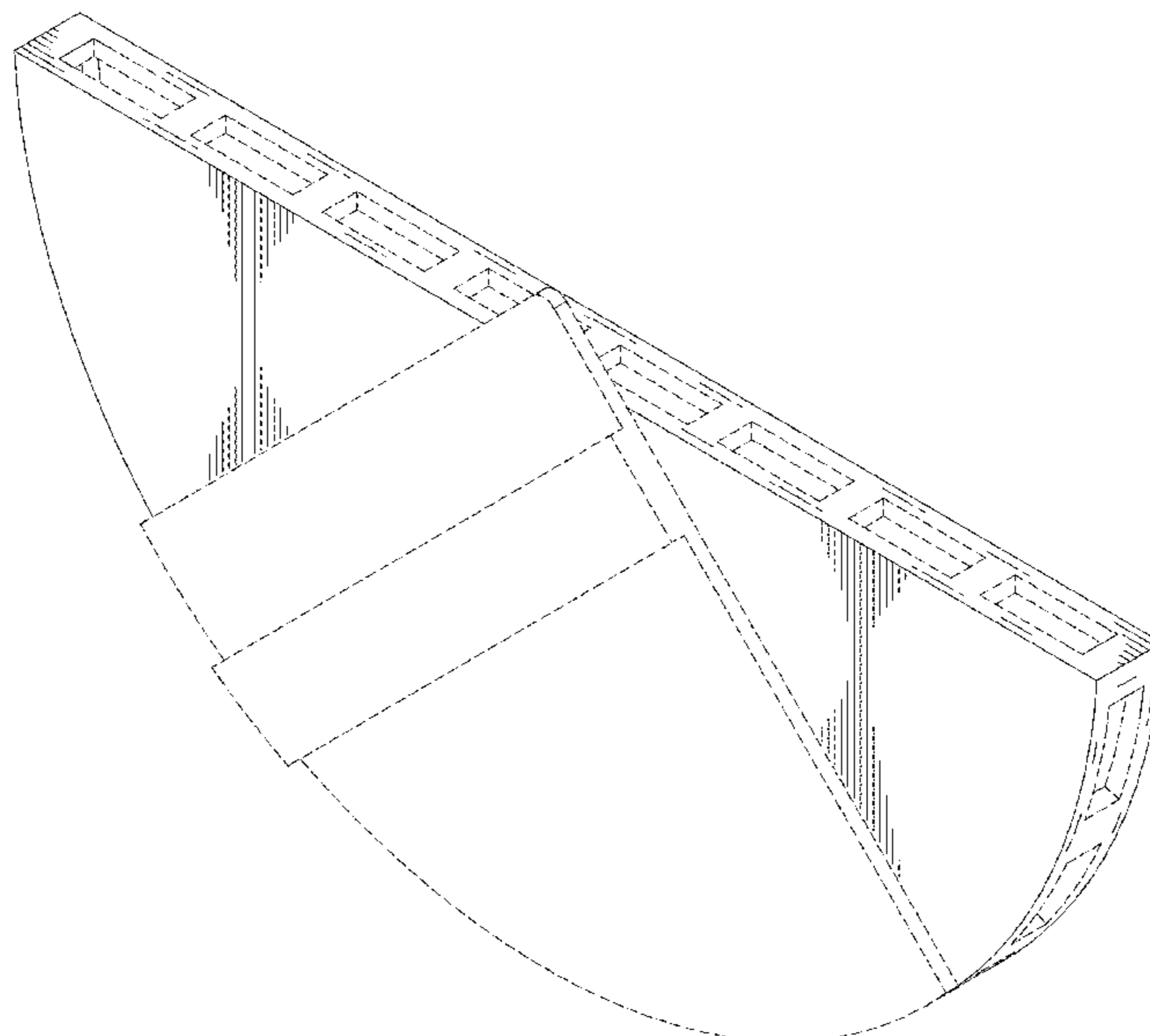

(56)

References Cited

U.S. PATENT DOCUMENTS

D827,881 S * 9/2018 Hannula D26/28
D851,808 S * 6/2019 Guercio D26/85
D862,771 S * 10/2019 Coombes D26/85
D869,062 S * 12/2019 Sonneman D26/118
D874,332 S * 2/2020 Lowy D11/131
2020/0275747 A1 * 9/2020 Newell A44C 7/00

OTHER PUBLICATIONS

Youtube The Da Vinci Pendant, May 9, 2018, [online], [site visited May 27, 2020]. Retrieved from url:<https://www.youtube.com/watch?v=70JPJNCWFal> (Year: 2018).*

Always Coco The Da Vinci Pendant, no date available, [online], [site visited May 27, 2020]. Retrieved from url:<https://shop.alwayscoco.com/collections/signature-pendants-core/products/the-da-vinci-pendant> (Year: 2020).*

5 Dallas Bloggers Using Their Influence for Good, May 16, 2018, [online], [site visited May 27, 2020]. Retrieved from url:<https://www.dmagazine.com/shopping-fashion/2018/05/5-dallas-bloggers-using-their-influence-for-good/> (Year: 2018).*

* cited by examiner

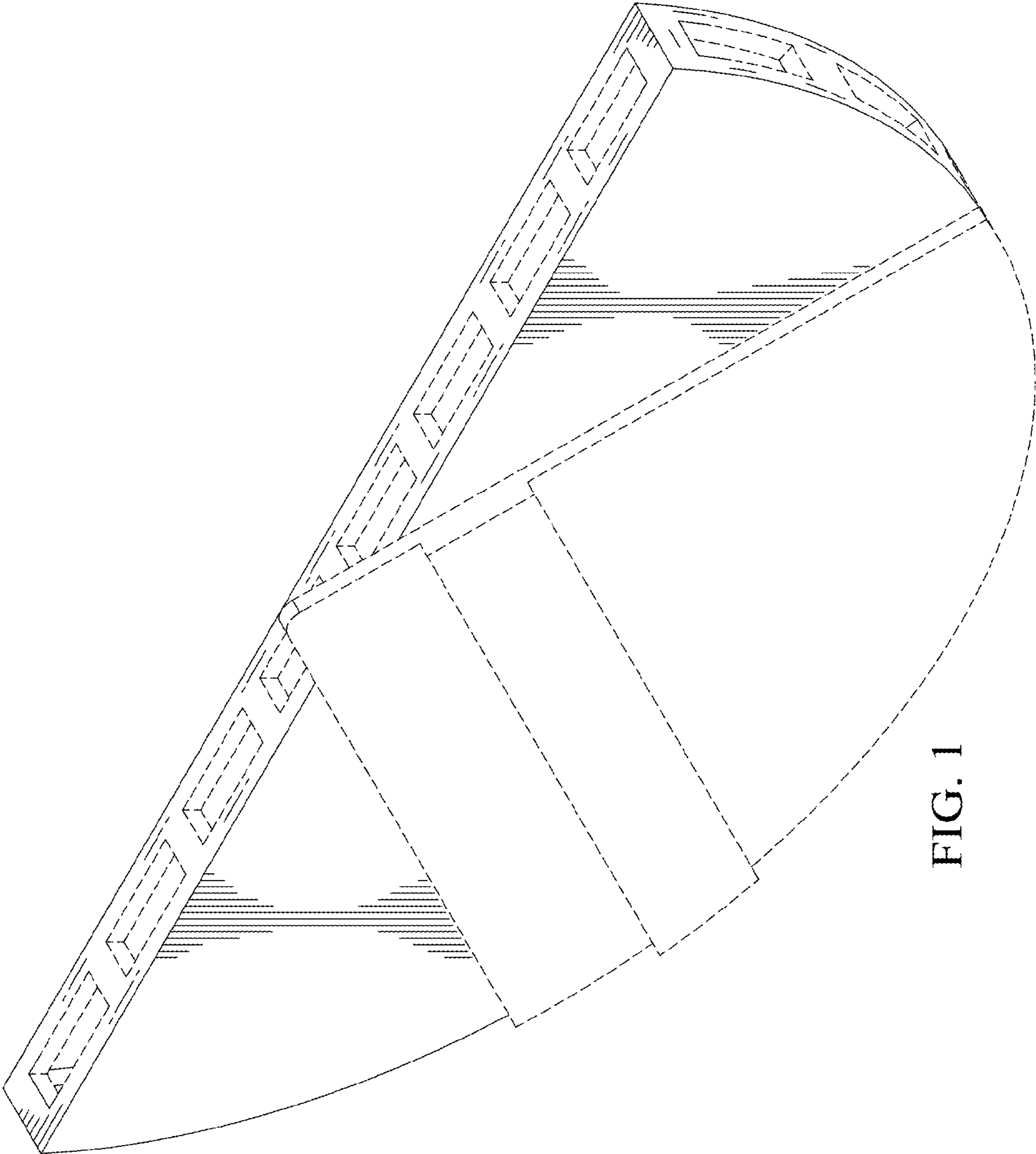

FIG. 1

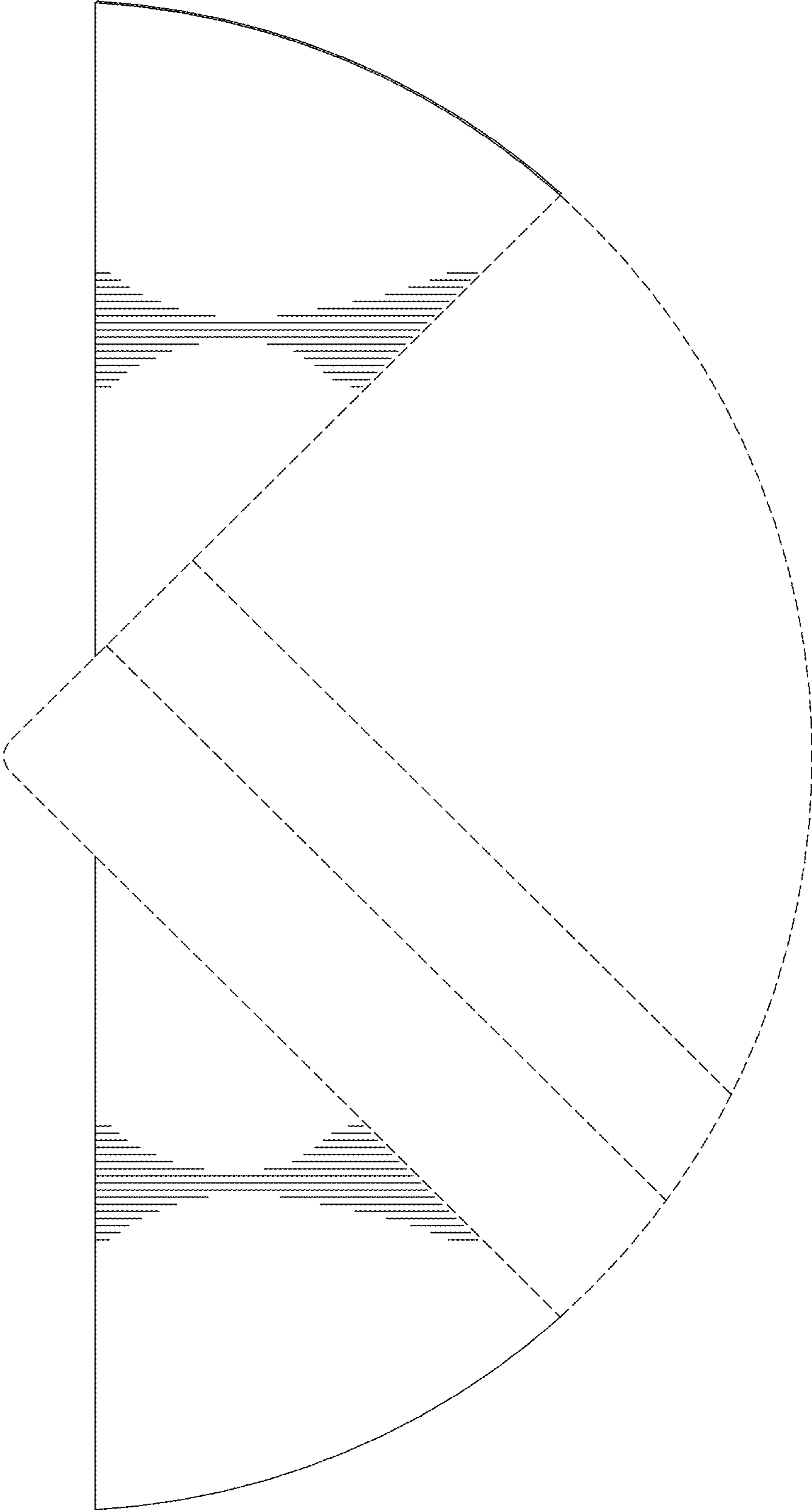

FIG. 2

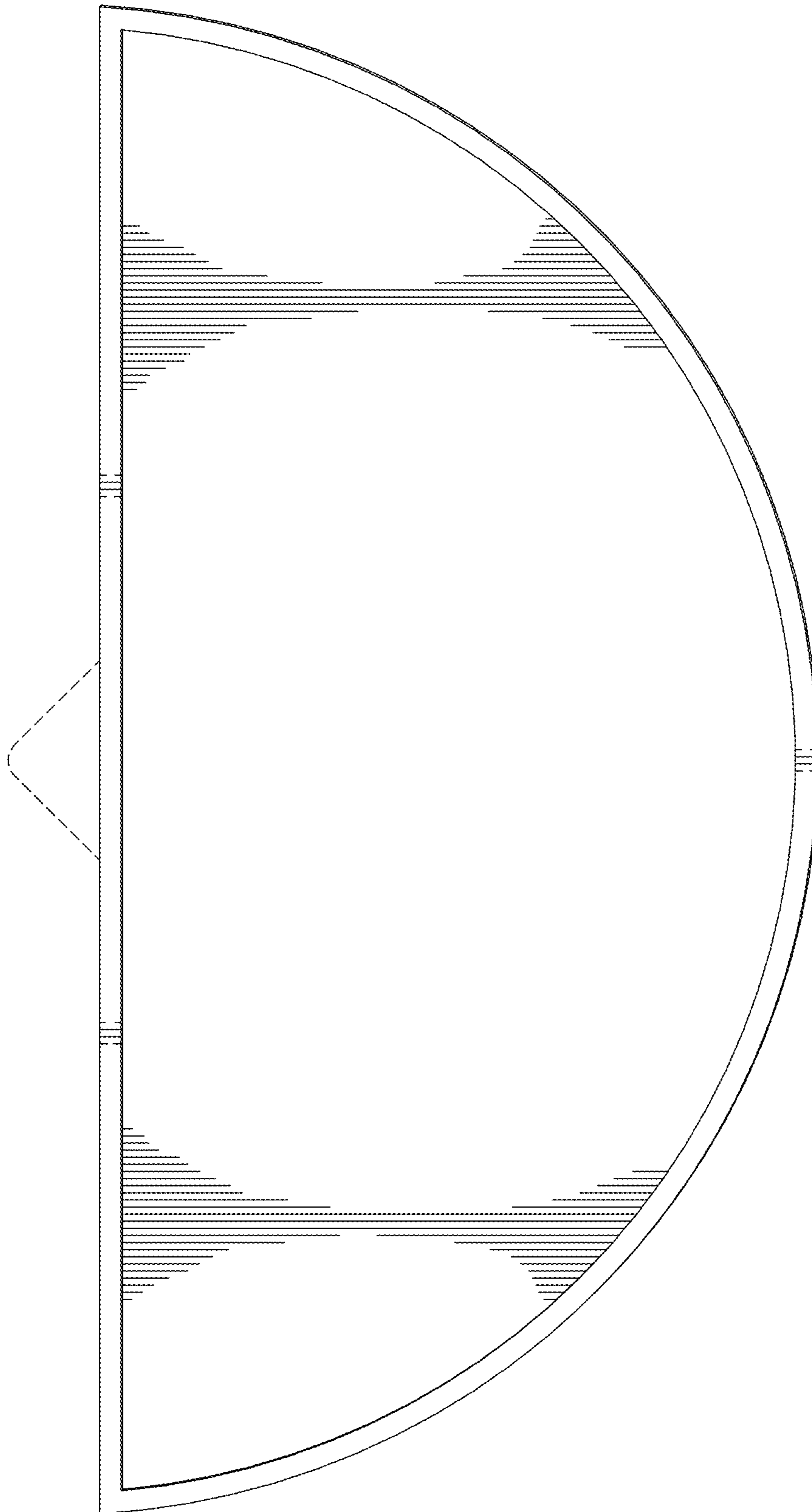

FIG. 3

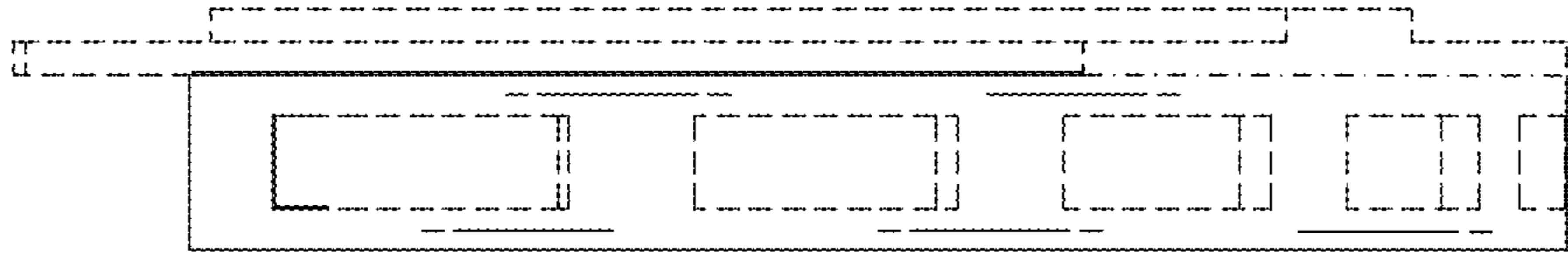

FIG. 5

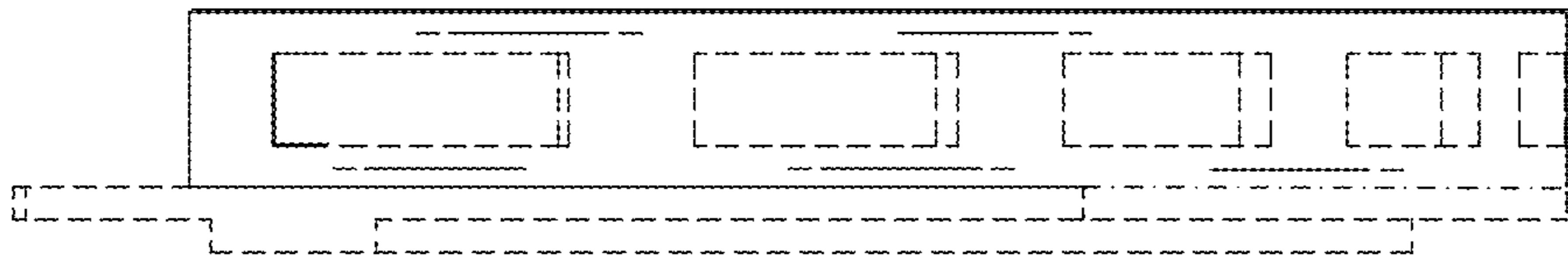

FIG. 4

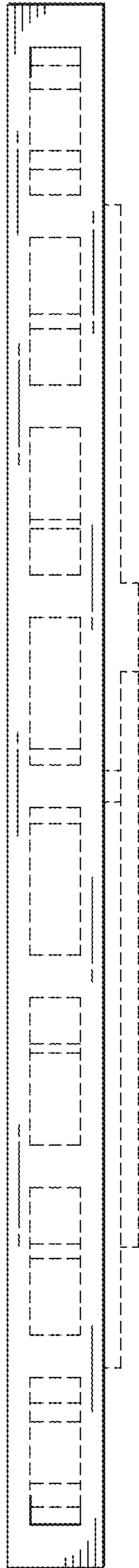

FIG. 6

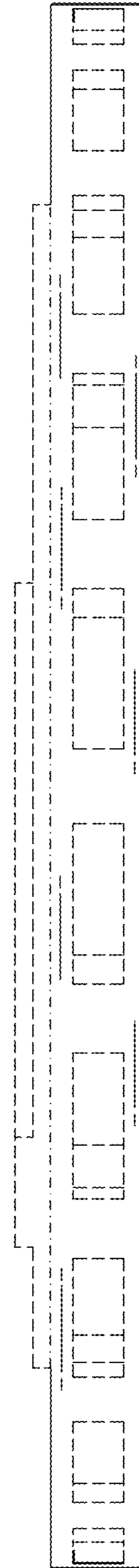

FIG. 7

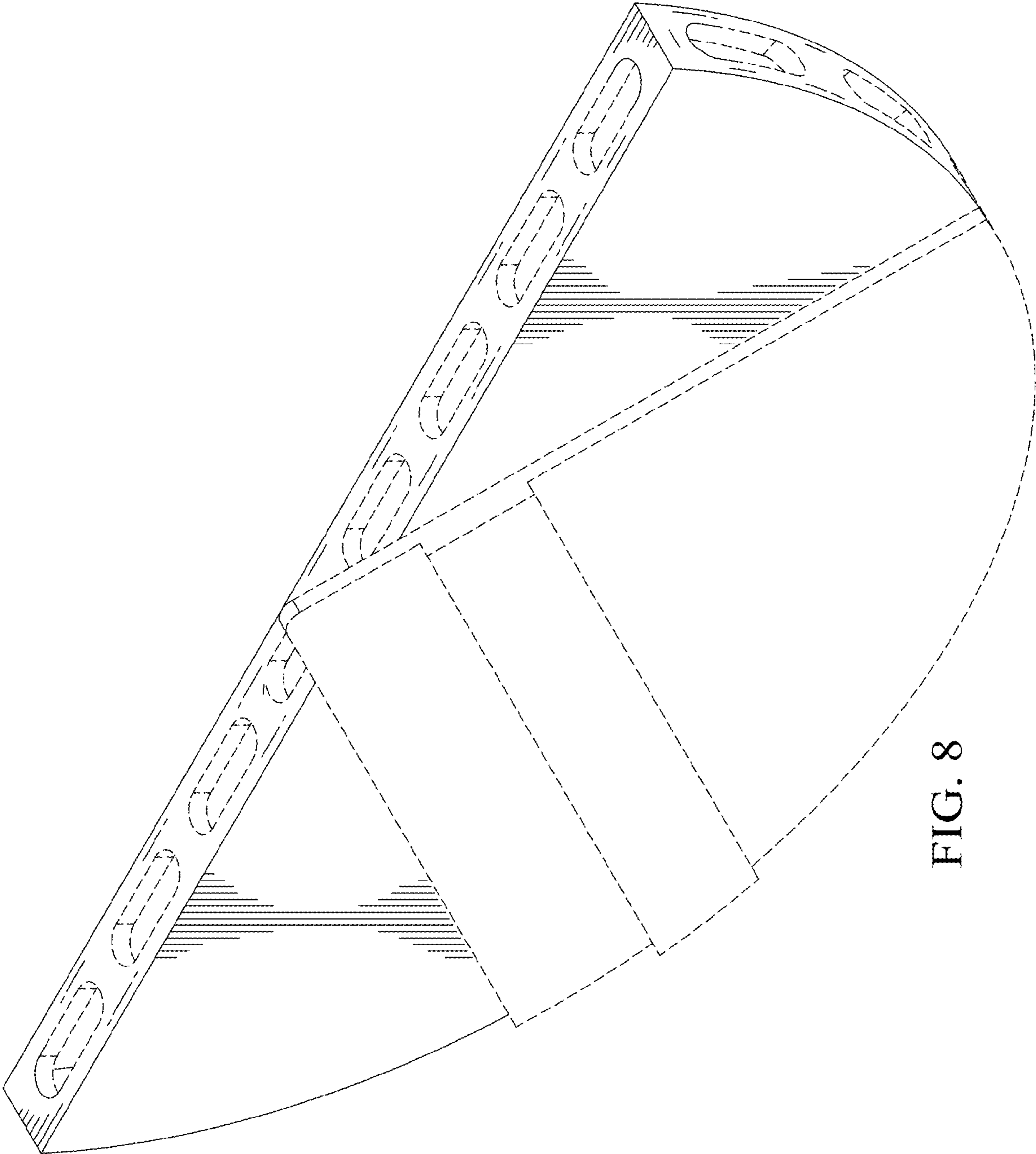

FIG. 8

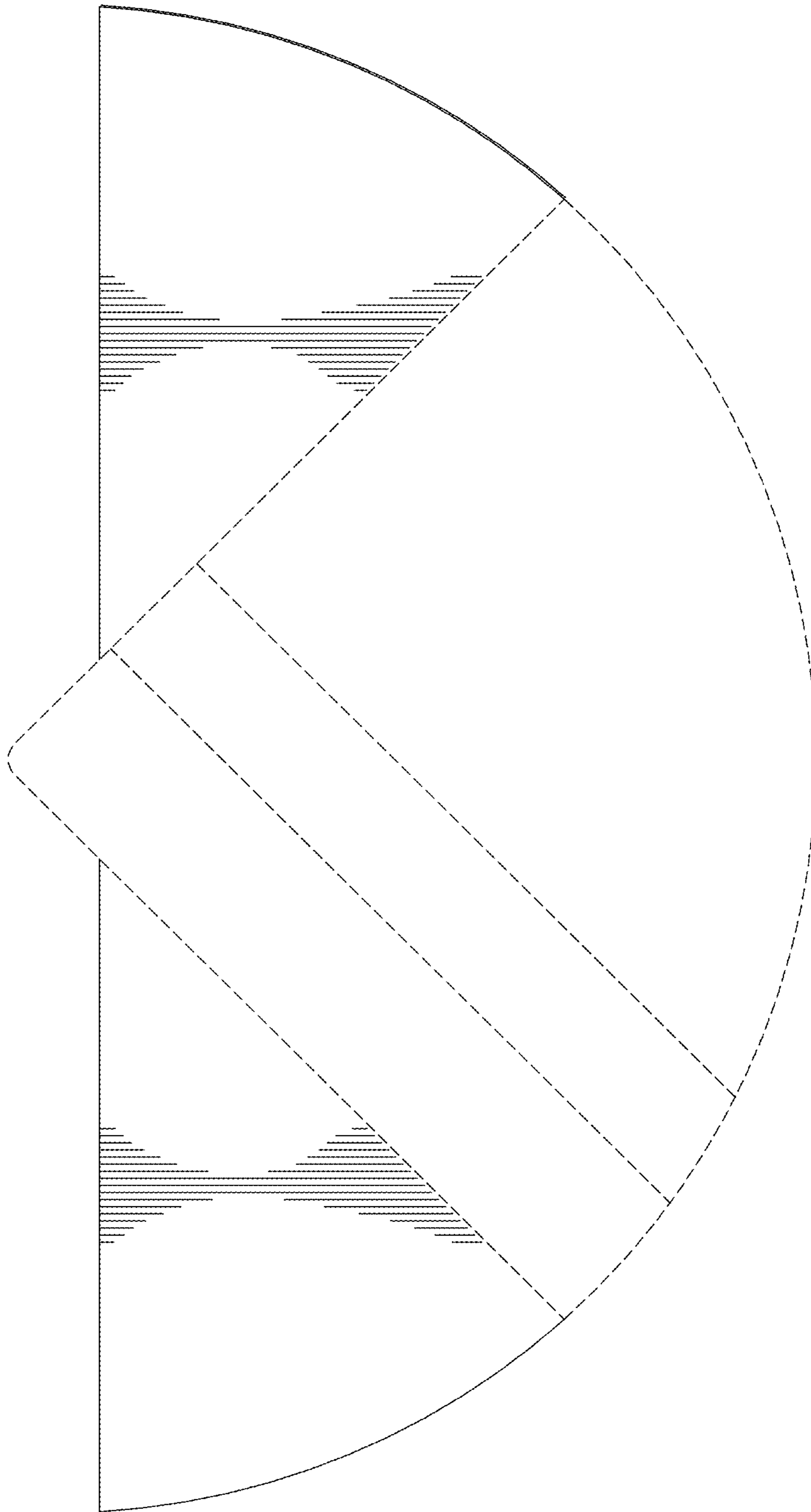

FIG. 9

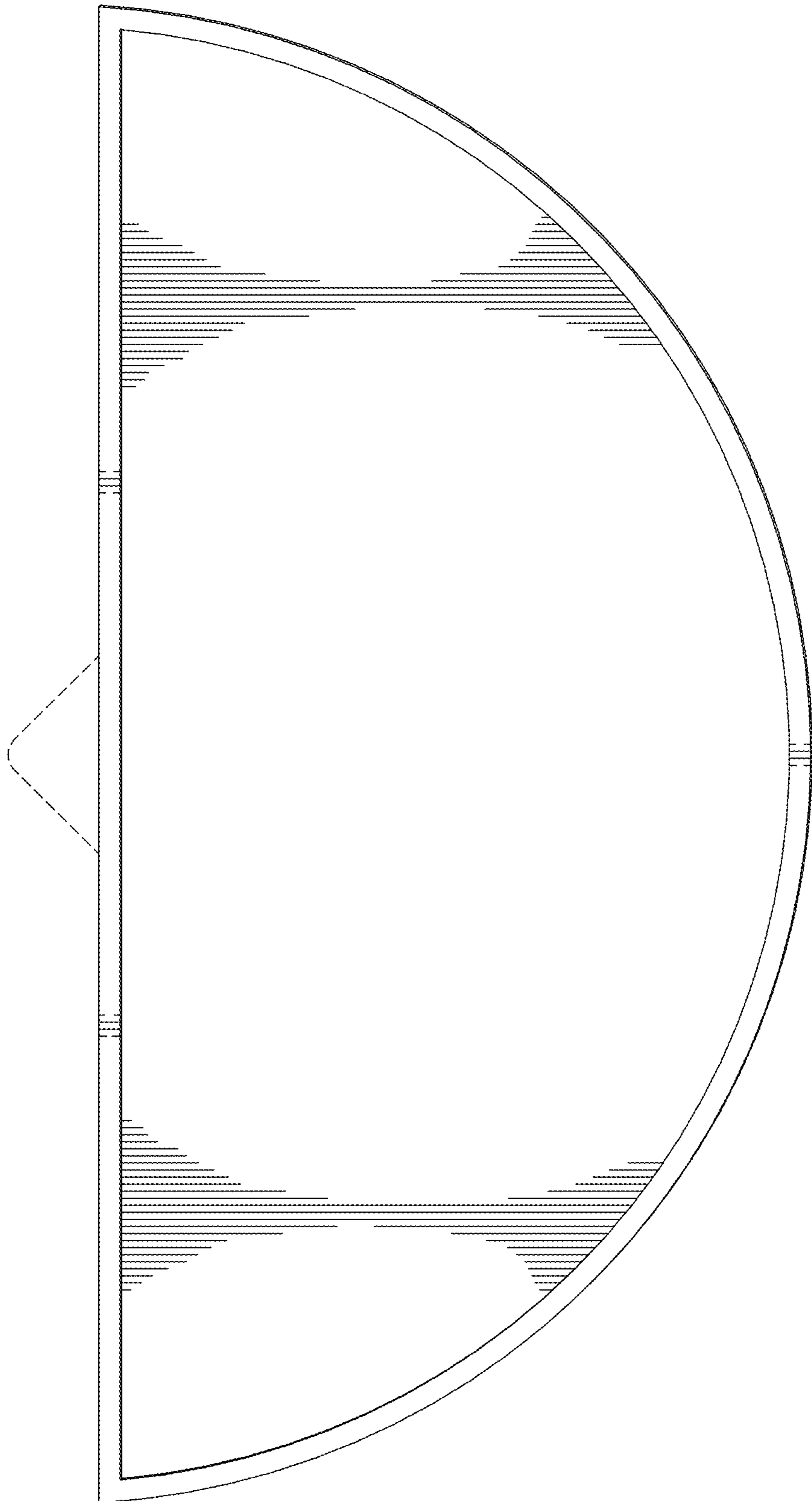

FIG. 10

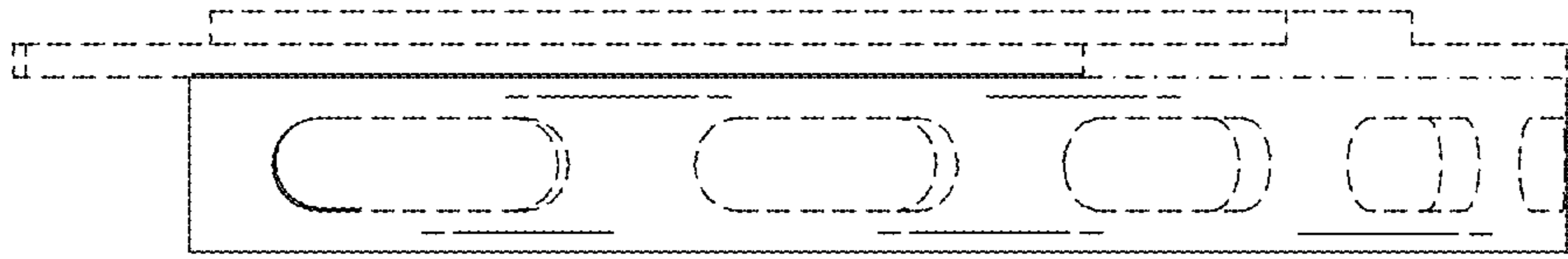

FIG. 11

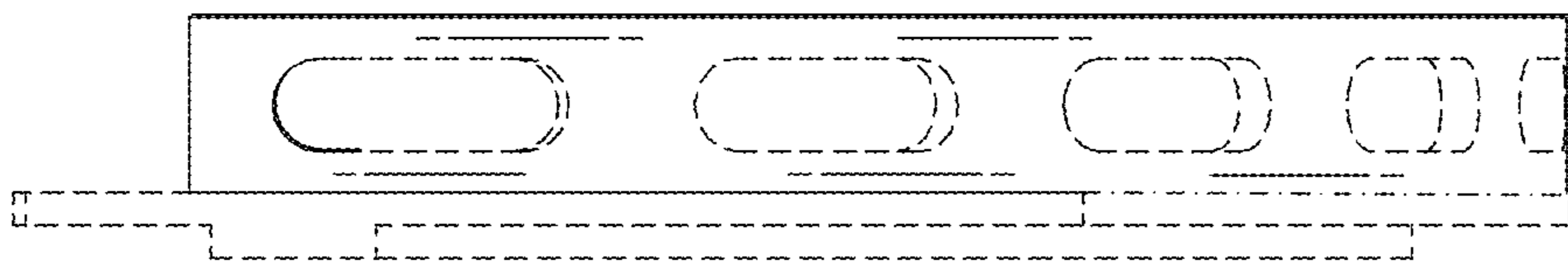

FIG. 12

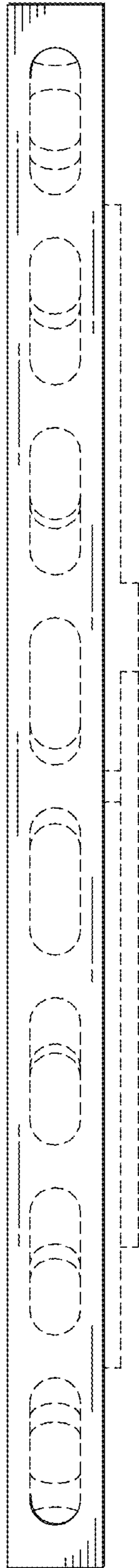

FIG. 13

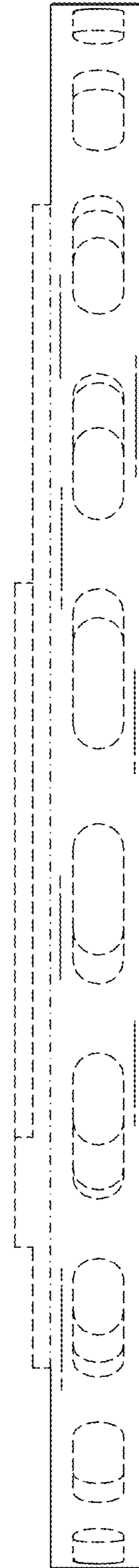

FIG. 14