



US00D918317S

(12) **United States Design Patent** (10) **Patent No.:** **US D918,317 S**
Servadei et al. (45) **Date of Patent:** **** May 4, 2021**

(54) **EXERCISE EQUIPMENT**

(71) Applicant: **TECHNOGYM S.p.A.**, Cesena (IT)
(72) Inventors: **Simone Servadei**, Cesena (IT); **Nerio Alessandri**, Cesena (IT); **Mario Fedriga**, Cesena (IT)
(73) Assignee: **TECHNOGYM S.p.A.**
(**) Term: **15 Years**

(21) Appl. No.: **29/685,730**

(22) Filed: **Mar. 29, 2019**

(30) **Foreign Application Priority Data**

Oct. 1, 2018 (EM) 005684024

(51) **LOC (13) Cl.** **21-02**

(52) **U.S. Cl.**
USPC **D21/669**

(58) **Field of Classification Search**
USPC D21/662, 668, 669, 670, 671, 686, 694
CPC A63B 22/02; A63B 2220/18; A63B 24/00;
A63B 69/0028
See application file for complete search history.

(56) **References Cited**

U.S. PATENT DOCUMENTS

D342,107 S *	12/1993	Chang	D21/669
D344,557 S *	2/1994	Ashby	482/54
D348,494 S *	7/1994	Ashby	D21/694
D361,807 S *	8/1995	Bartlett	D21/669
D366,077 S *	1/1996	Hung	D21/669
D372,508 S *	8/1996	Clem	D21/669
D374,260 S *	10/1996	Snyderman	D21/669
D387,402 S *	12/1997	Coody	D21/669
D392,351 S *	3/1998	Coody	D21/669
D393,297 S *	4/1998	McBride	D21/669

(Continued)

OTHER PUBLICATIONS

Gymmarine, "Technogynn Artis Treadmill", Sep. 2, 2020. <https://www.gymmarine.com/product/technogym-artis-treadmill/>. Shown on p. 1. (Year: 2020).*

Primary Examiner — Cynthia Ramirez
Assistant Examiner — Michael A Maharajh
(74) *Attorney, Agent, or Firm* — Thomas | Horstemeyer, LLP

(57) **CLAIM**

The ornamental design for exercise equipment, as shown and described.

DESCRIPTION

The patent or application file contains at least one drawing executed in color. Copies of this patent or patent application publication with color drawing(s) will be provided by the Office upon request and payment of the necessary fee.

FIG. 1 is a perspective view of exercise equipment, showing our new design;
FIG. 2 is a rear view thereof;
FIG. 3 is a front view thereof;
FIG. 4 is a side view thereof;
FIG. 5 is a side view thereof, from a side opposite that of FIG. 4;
FIG. 6 is a top view thereof;
FIG. 7 is a bottom view thereof;
FIG. 8 is a perspective view of an embodiment of the exercise equipment of FIG. 1 in which color is an integral part of the design;
FIG. 9 is a rear view of the embodiment of FIG. 8;
FIG. 10 is a front view of the embodiment of FIG. 8;
FIG. 11 is a side view of the embodiment of FIG. 8;
FIG. 12 is a side view of the embodiment of FIG. 8; from a side opposite that of FIG. 11;
FIG. 13 is a top view of the embodiment of FIG. 8; and,
FIG. 14 is a bottom view of the embodiment of FIG. 8.

1 Claim, 14 Drawing Sheets
(2 of 14 Drawing Sheet(s) Filed in Color)

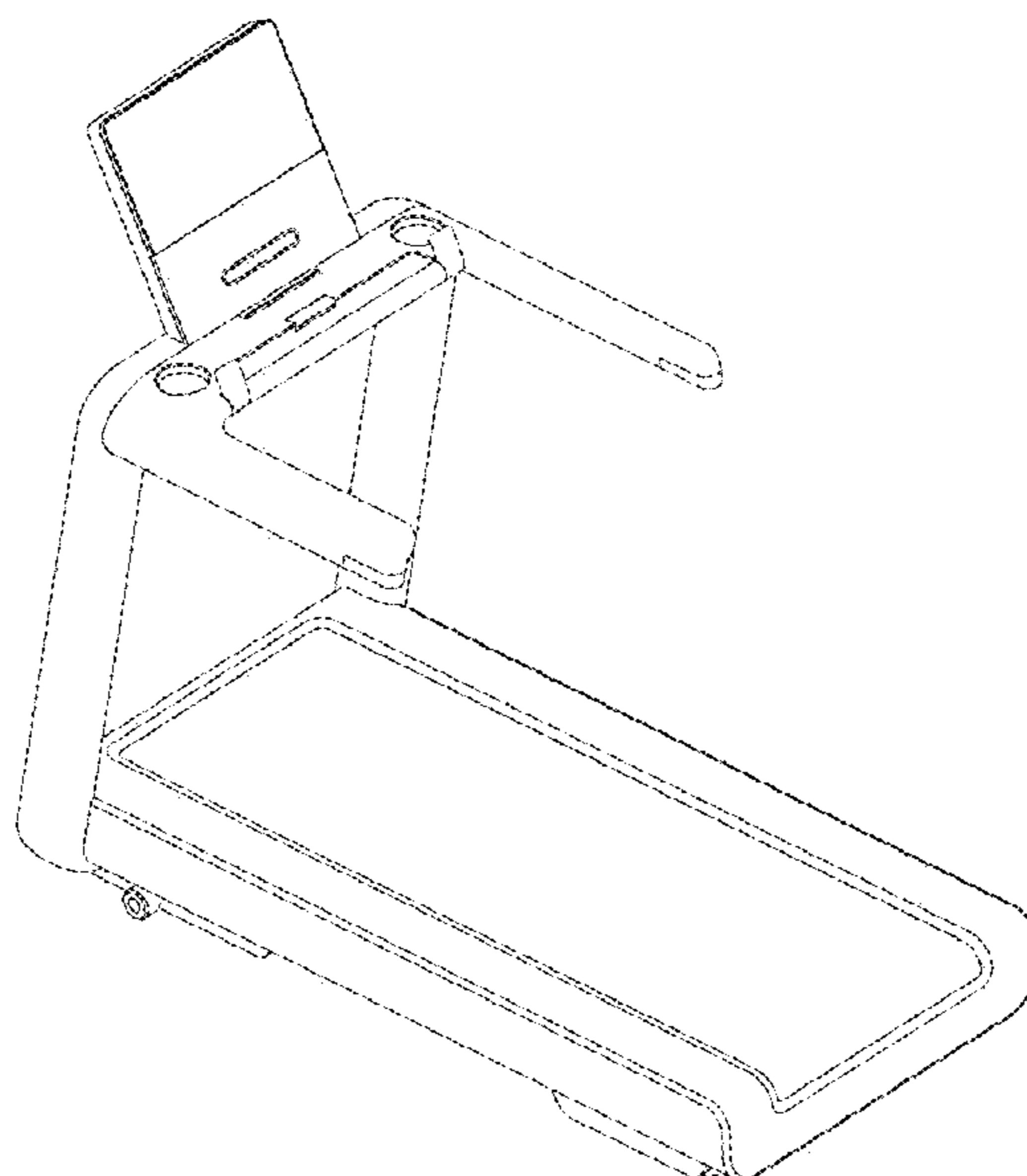

(56)

References Cited

U.S. PATENT DOCUMENTS

D403,034 S * 12/1998 Moon D21/669
 D414,518 S * 9/1999 Wang D21/669
 D416,298 S * 11/1999 Onuma D21/669
 D424,137 S * 5/2000 Barker D21/669
 D437,900 S * 2/2001 Dick D21/669
 D445,152 S * 7/2001 Wang D21/669
 D447,780 S * 9/2001 Arnold D21/669
 D450,792 S * 11/2001 Kuo D21/669
 6,390,955 B1 * 5/2002 Wang A63B 22/02
 482/54
 D494,234 S * 8/2004 Sporie D21/669
 D496,699 S * 9/2004 Dobson D21/669
 D500,348 S * 12/2004 Parise D21/669
 D521,577 S * 5/2006 Wu D21/669
 D523,099 S * 6/2006 Clifton D21/669
 D531,683 S * 11/2006 Choi D21/696
 7,141,006 B1 * 11/2006 Chen A63B 22/02
 482/54
 D546,909 S * 7/2007 Flick D21/694
 D559,342 S * 1/2008 Moon D21/694
 D579,992 S * 11/2008 Cesaroni D21/694
 D601,644 S * 10/2009 Kim D21/696
 D607,067 S * 12/2009 Wu D21/669
 D657,833 S * 4/2012 Cloutier D21/694
 D682,372 S * 5/2013 Alessandri D21/669
 D728,710 S * 5/2015 Koduri D21/694
 D751,156 S * 3/2016 Tasca D21/669
 D831,131 S * 10/2018 Zha D21/669
 10,130,845 B2 * 11/2018 Alessandri A63B 24/0075
 D854,634 S * 7/2019 Zhao D21/669
 D888,845 S * 6/2020 Luo D21/669
 D889,569 S * 7/2020 Luo D21/669
 2003/0224909 A1 * 12/2003 Lo A63B 21/0051
 482/54
 2007/0015635 A1 * 1/2007 Donner A63B 22/02
 482/54
 2007/0049466 A1 * 3/2007 Hubbard A63B 24/00
 482/54
 2008/0249421 A1 * 10/2008 Twery A61B 5/6843
 600/481

2008/0312046 A1 * 12/2008 Lin A63B 22/02
 482/54
 2009/0005224 A1 * 1/2009 Davis A63B 22/02
 482/54
 2013/0123073 A1 * 5/2013 Olson A63B 22/0023
 482/54
 2013/0196827 A1 * 8/2013 Chang A63B 22/02
 482/54
 2013/0231219 A1 * 9/2013 Huang A63B 22/0023
 482/54
 2014/0121066 A1 * 5/2014 Huang A63B 22/02
 482/54
 2015/0080187 A1 * 3/2015 Beane A63B 69/0064
 482/51
 2015/0111703 A1 * 4/2015 Verheem A63B 21/00196
 482/54
 2015/0133268 A1 * 5/2015 Verheem A63B 22/0214
 482/4
 2015/0182783 A1 * 7/2015 Cutler A63B 71/0622
 482/54
 2015/0190676 A1 * 7/2015 Wang A63B 24/0075
 482/9
 2015/0196805 A1 * 7/2015 Koduri G06T 7/00
 482/6
 2015/0367175 A1 * 12/2015 Alessandri A63B 24/0075
 482/8
 2016/0213980 A1 * 7/2016 Chen H04M 1/725
 2016/0339299 A1 * 11/2016 Gronachan A61B 5/486
 2017/0281079 A1 * 10/2017 Nachman A61B 5/4866
 2017/0340917 A1 * 11/2017 Chang B32B 3/266
 2018/0036585 A1 * 2/2018 Powell A63B 22/0257
 2018/0099179 A1 * 4/2018 Chatterton A63B 22/0242
 2018/0099180 A1 * 4/2018 Wilkinson B60B 33/066
 2018/0099181 A1 * 4/2018 Powell H02P 1/00
 2018/0104533 A1 * 4/2018 Powell A63B 22/0023
 2018/0147440 A1 * 5/2018 Lin A63B 21/4047
 2019/0240532 A1 * 8/2019 Bellman A63B 22/02
 2019/0275366 A1 * 9/2019 Powell A63B 24/0087
 2019/0329091 A1 * 10/2019 Powell A63B 24/0062
 2020/0146592 A1 * 5/2020 Tsukada A61B 5/6807
 2020/0222749 A1 * 7/2020 Yan A63B 21/154
 2020/0222750 A1 * 7/2020 Salicio Castillo A63B 22/02

* cited by examiner

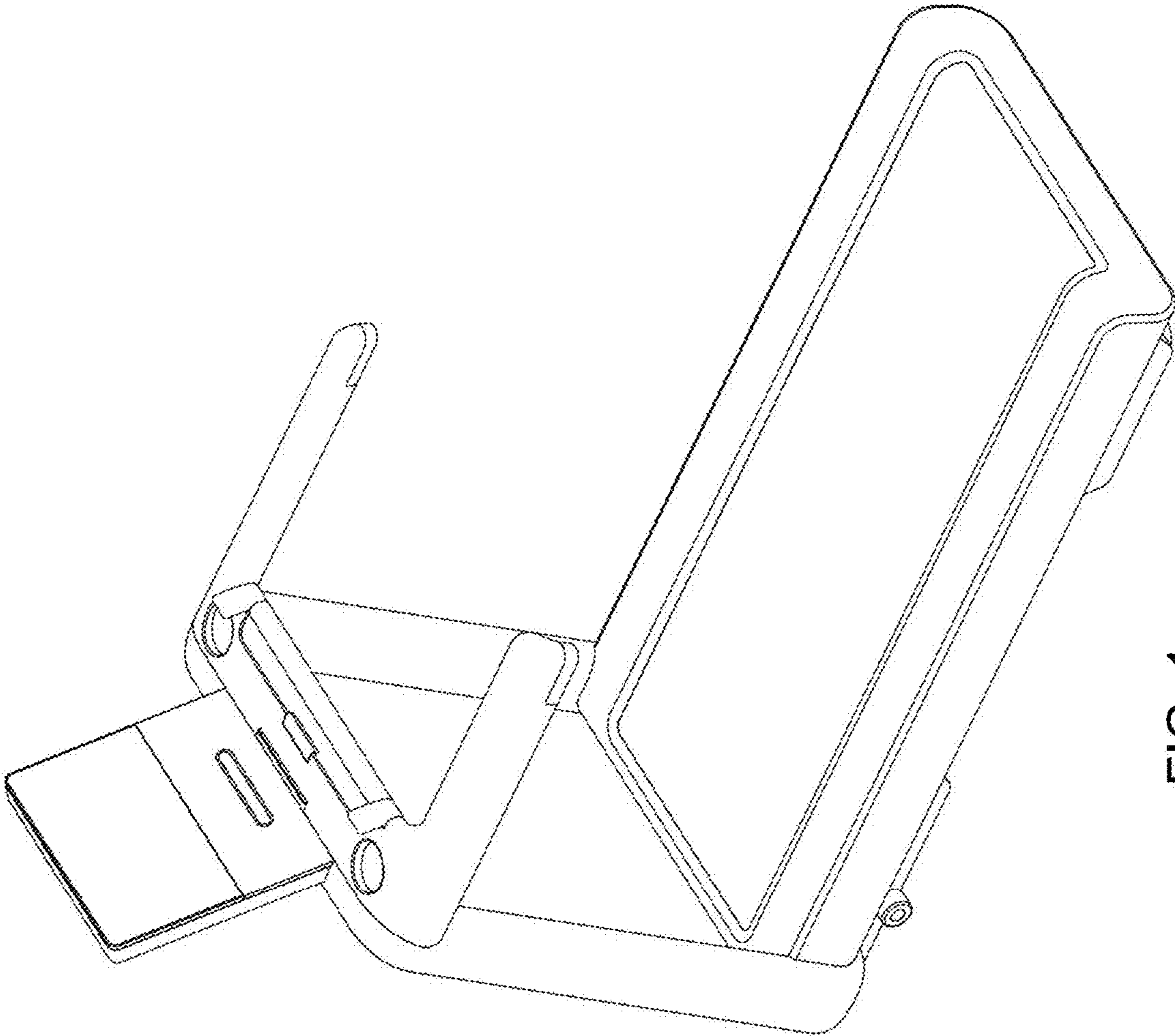

FIG. 1

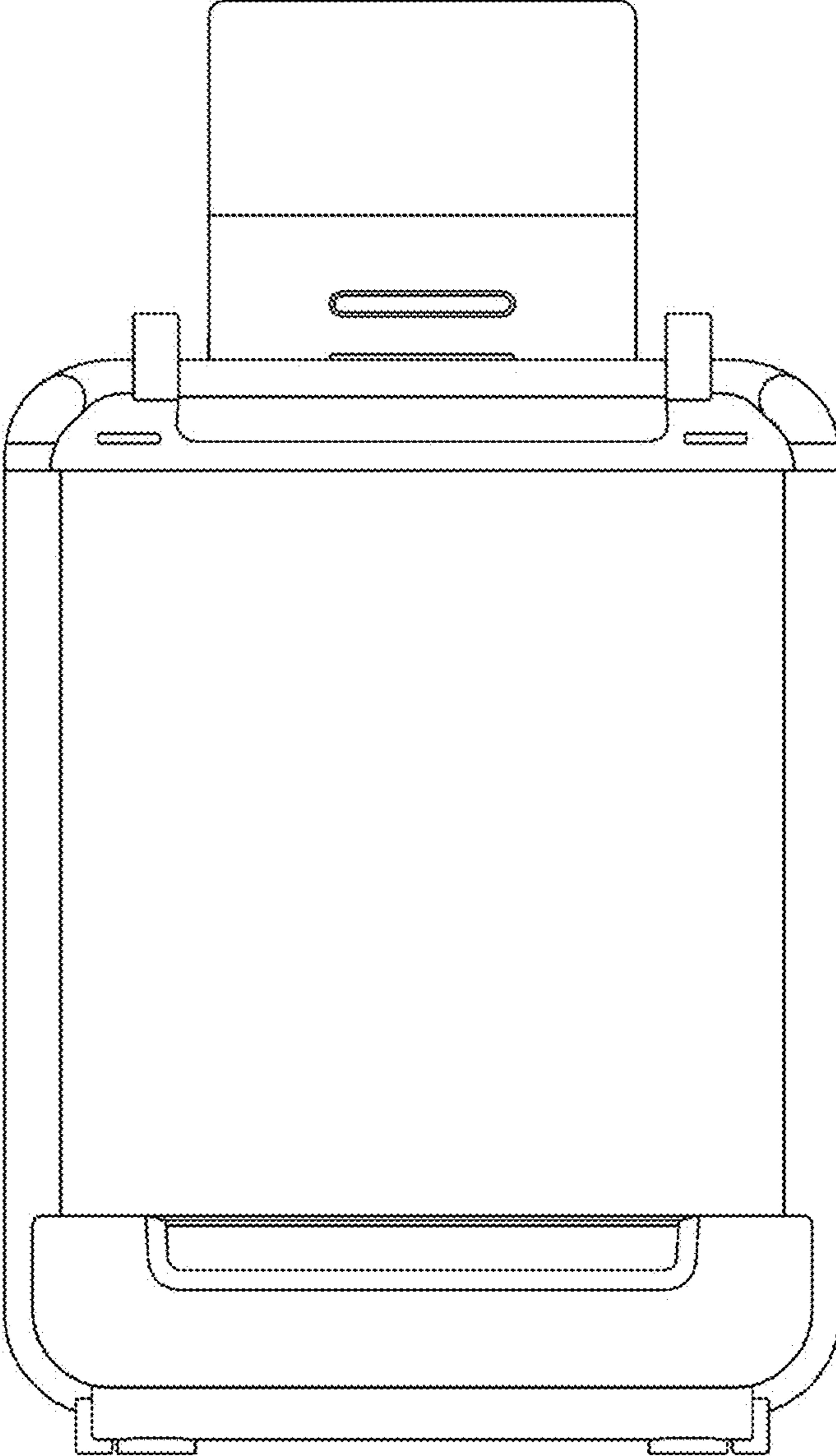

FIG. 2

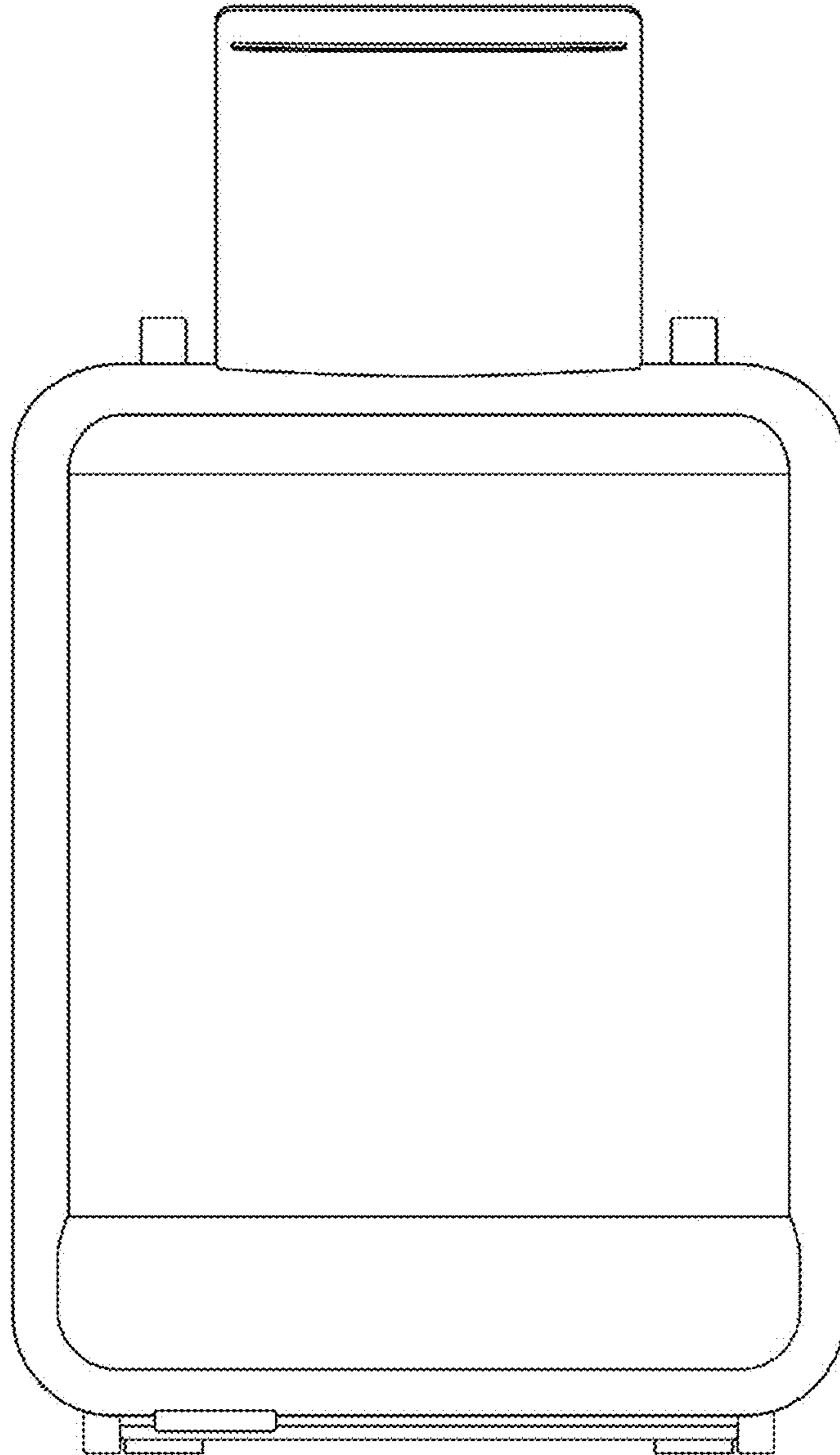

FIG. 3

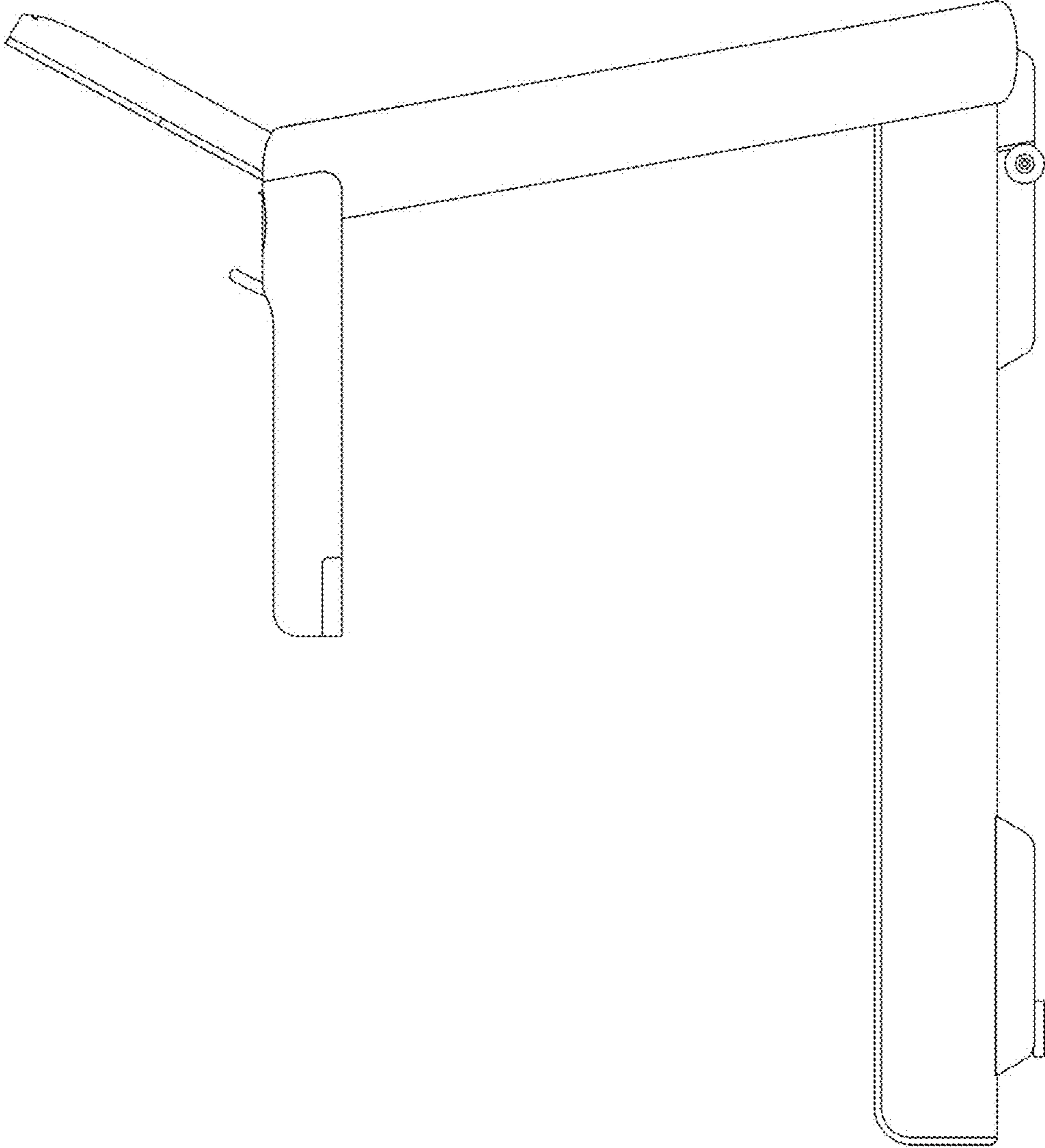

FIG. 4

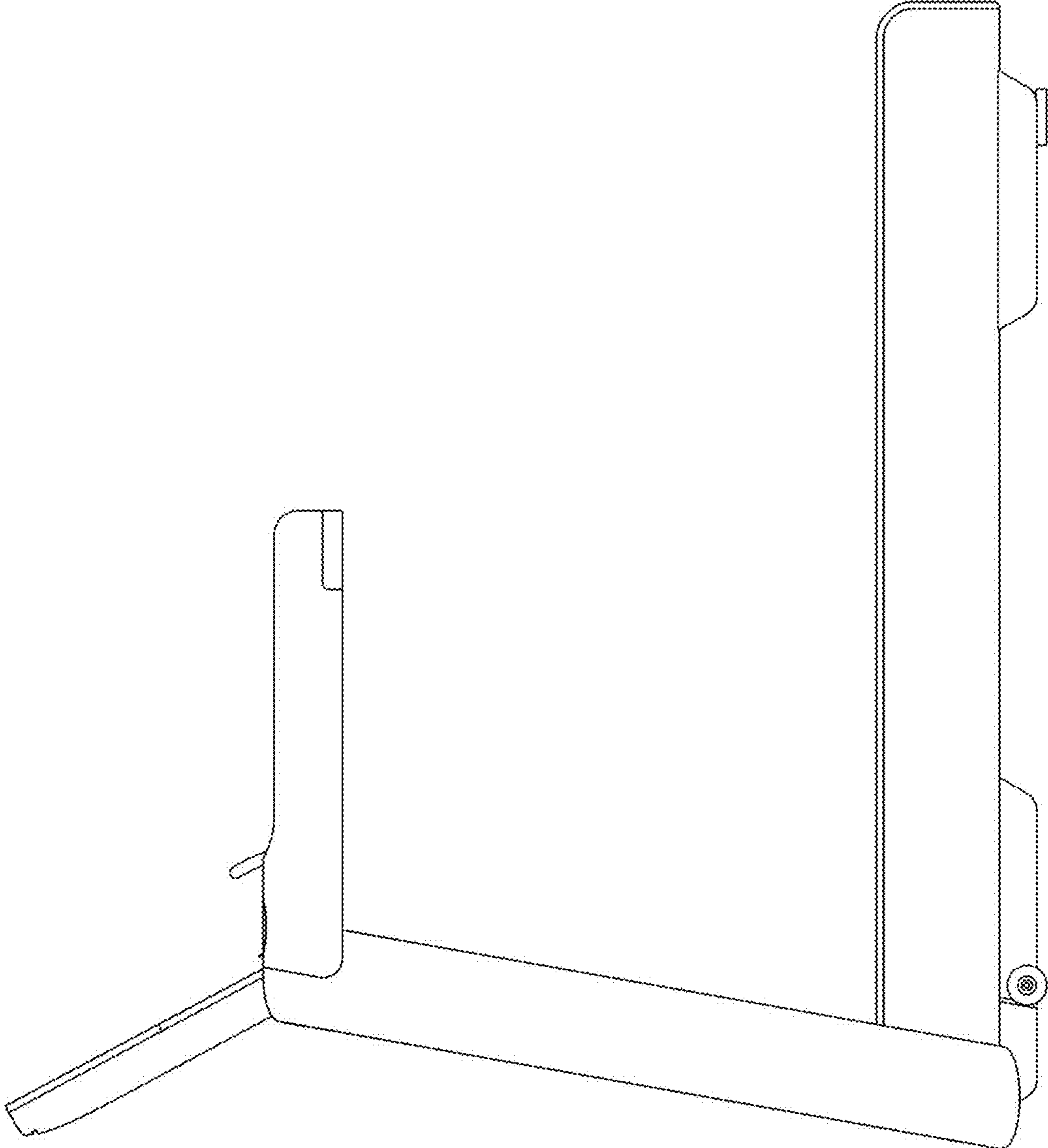

FIG. 5

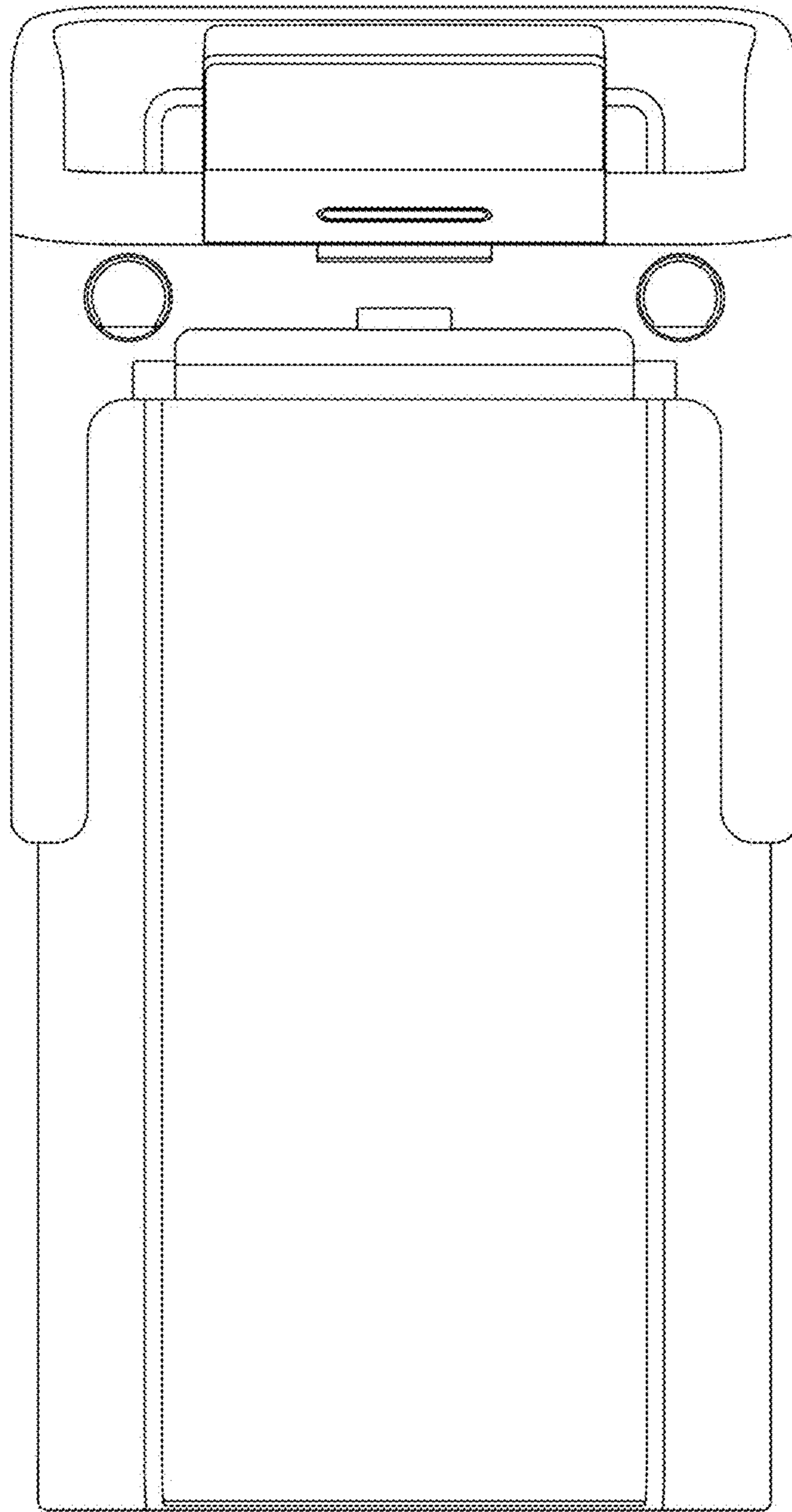

FIG. 6

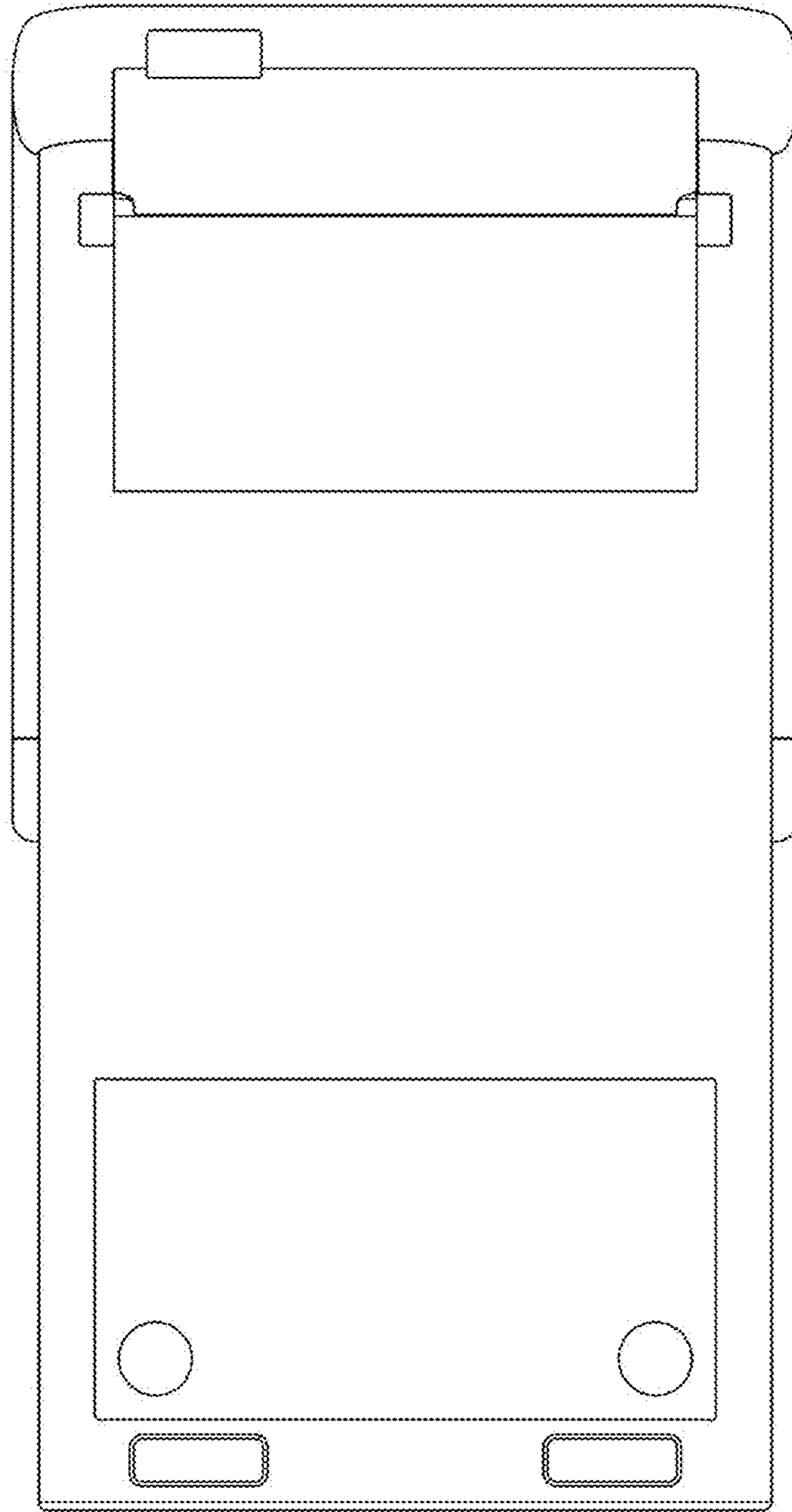

FIG. 7



FIG. 8



FIG. 9



FIG. 10



FIG. 11



FIG. 12



FIG. 13



FIG. 14