



US00D918305S

(12) **United States Design Patent**  
**Fan et al.**

(10) **Patent No.:** **US D918,305 S**

(45) **Date of Patent:** **\*\* May 4, 2021**

(54) **SCOOTER**

(71) Applicant: **HONGJI INTELLIGENT BIKE CO., LTD**, Changzhou (CN)

(72) Inventors: **Feng Fan**, Changzhou (CN); **Meng Zhu**, Changzhou (CN); **Yang Li**, Changzhou (CN)

(\*\*) Term: **15 Years**

(21) Appl. No.: **29/710,074**

(22) Filed: **Oct. 21, 2019**

(30) **Foreign Application Priority Data**

Oct. 8, 2019 (CN) ..... 201930544912.9

(51) **LOC (13) Cl.** ..... **21-01**

(52) **U.S. Cl.**  
USPC ..... **D21/423**

(58) **Field of Classification Search**  
USPC ..... D21/419, 421, 423, 432, 435, 760, 763,  
D21/765, 771; D12/1, 110

CPC ..... B62K 3/002; B62K 9/00; B62K 2202/00;  
B62K 15/00; B62K 2015/001; B62K  
2015/003; B60Y 2200/126

See application file for complete search history.

(56) **References Cited**

**U.S. PATENT DOCUMENTS**

D829,826 S \* 10/2018 Liu ..... D21/423  
D834,097 S \* 11/2018 Lin ..... D21/423  
D849,153 S \* 5/2019 Zhang ..... D21/423  
D858,647 S \* 9/2019 Liu ..... D21/423  
D872,191 S \* 1/2020 Lee ..... D21/423  
D886,907 S \* 6/2020 Gao ..... D21/423

D897,446 S \* 9/2020 Lee ..... D21/423  
D900,237 S \* 10/2020 Lee ..... D21/423  
D905,793 S \* 12/2020 Yang ..... D21/423  
D905,794 S \* 12/2020 Liu ..... D21/423  
2020/0283086 A1\* 9/2020 Ulmen ..... B62M 6/65

\* cited by examiner

*Primary Examiner* — Cynthia M. Chin

(57) **CLAIM**

The ornamental design for a scooter, as shown and described.

**DESCRIPTION**

FIG. 1 is a first perspective view of a scooter showing my new design;

FIG. 2 is a second perspective view thereof;

FIG. 3 is a front view thereof;

FIG. 4 is a back view thereof;

FIG. 5 is a left side view thereof;

FIG. 6 is a right side view thereof;

FIG. 7 is a top view thereof;

FIG. 8 is a bottom view thereof;

FIG. 9 is an enlarged partial view of the handlebar area taken from the top of FIG. 1;

FIG. 10 is an enlarged partial view of the kickstand area taken from the bottom of FIG. 1;

FIG. 11 is an enlarged partial view of the rear wheel area taken from the left of FIG. 2; and,

FIG. 12 is an enlarged partial view of the front of the scooter taken from the bottom of FIG. 2.

The broken lines are for the purpose of illustrating portions of the scooter that form no part of the claimed design. The dash-dot broken lines represent the boundaries of the enlarged partial views of FIGS. 9-12 and form no part of the claimed design.

**1 Claim, 12 Drawing Sheets**

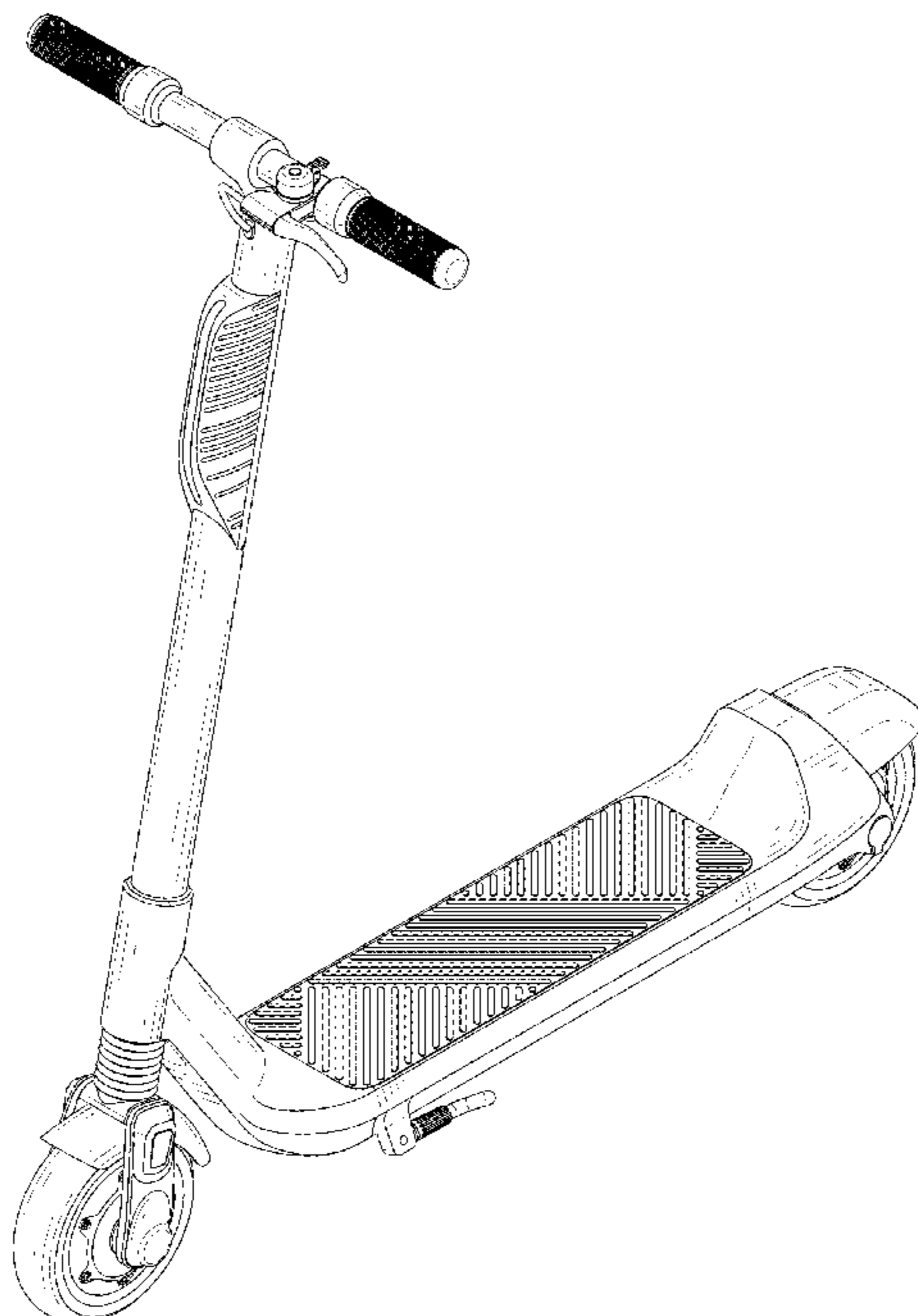

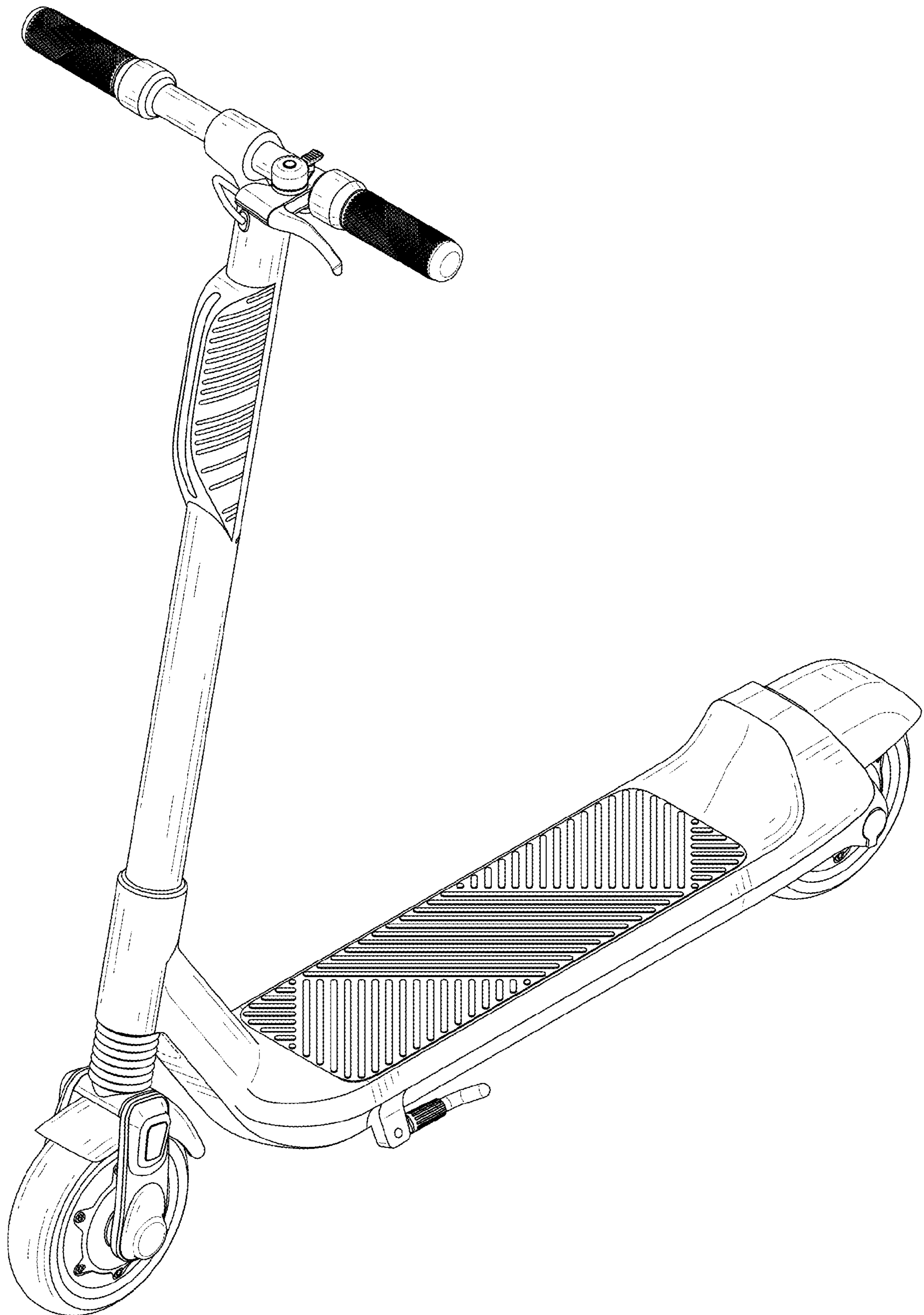

FIG. 1

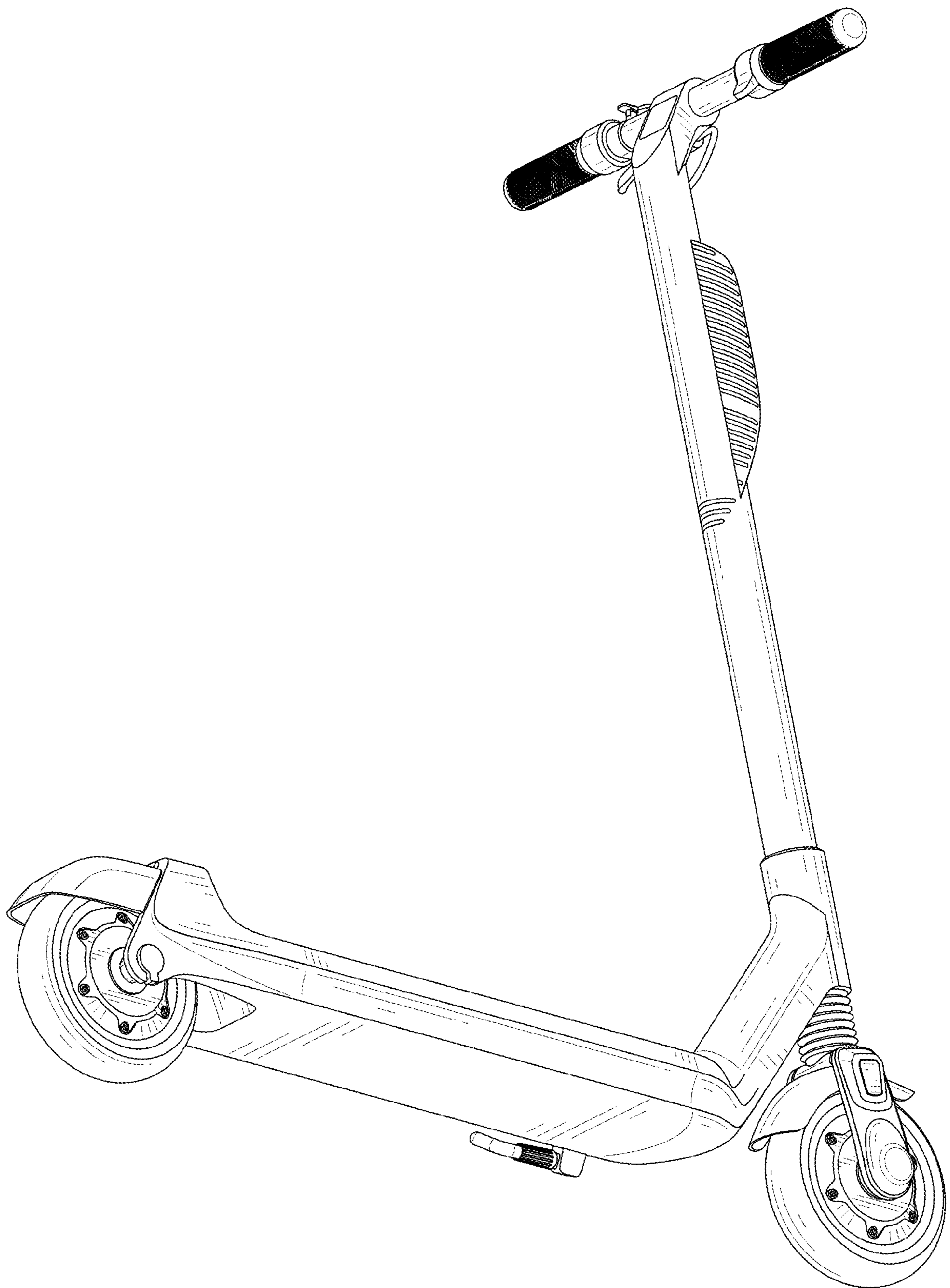

FIG. 2

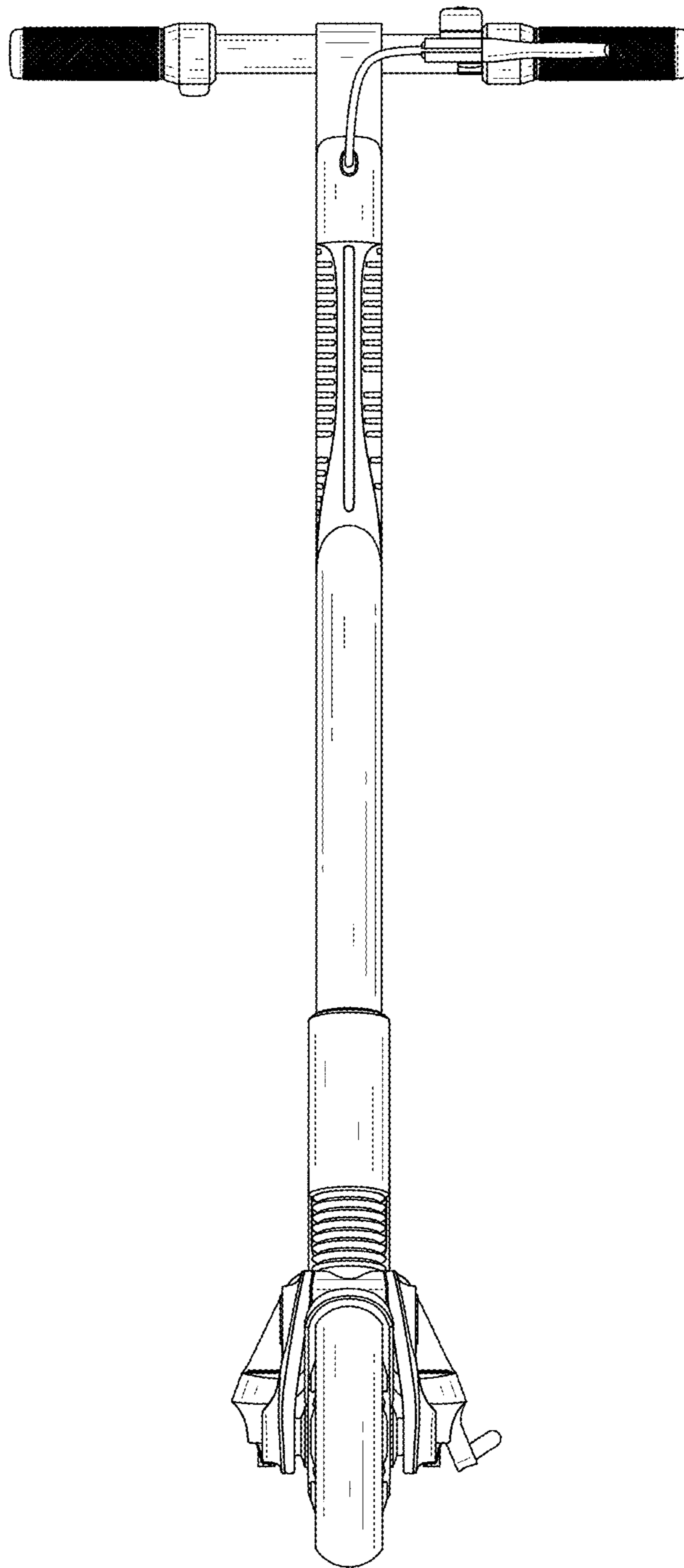

FIG. 3

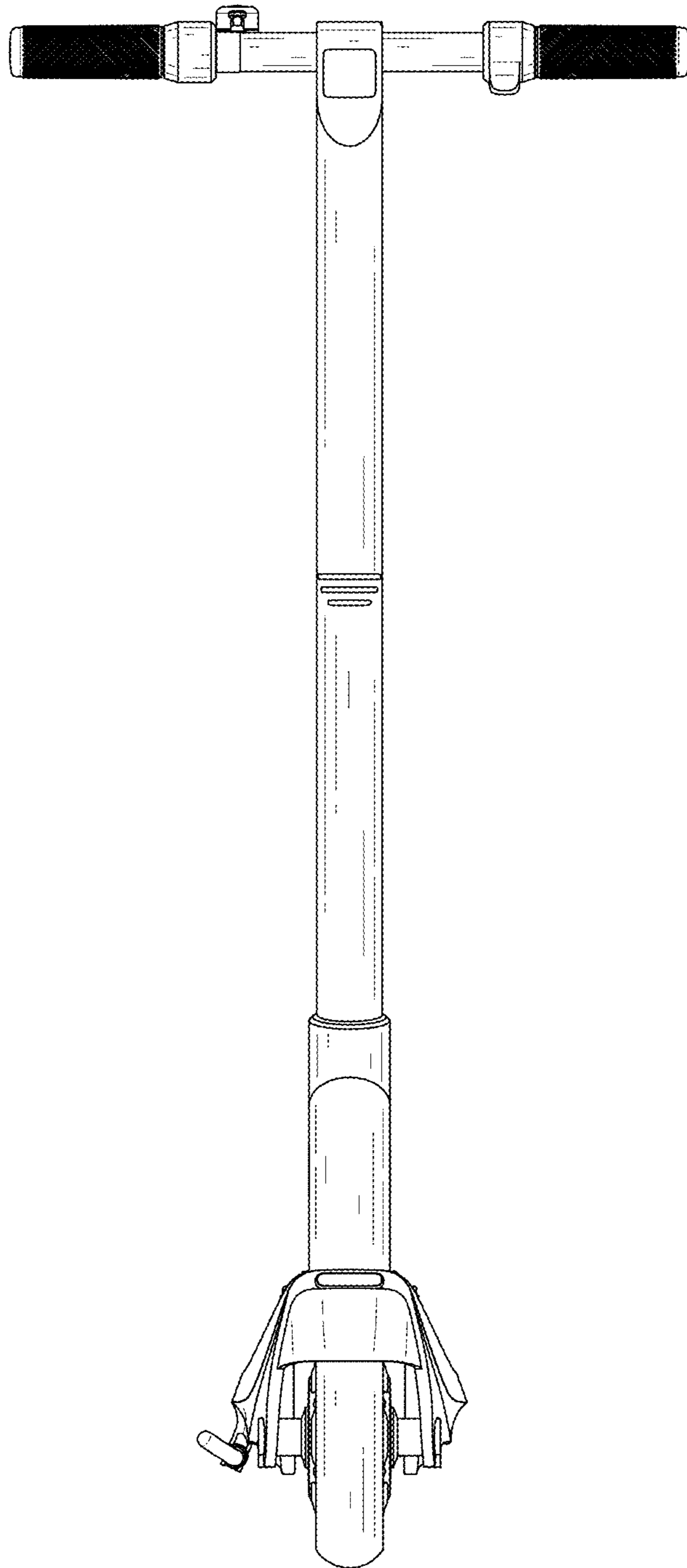

FIG. 4

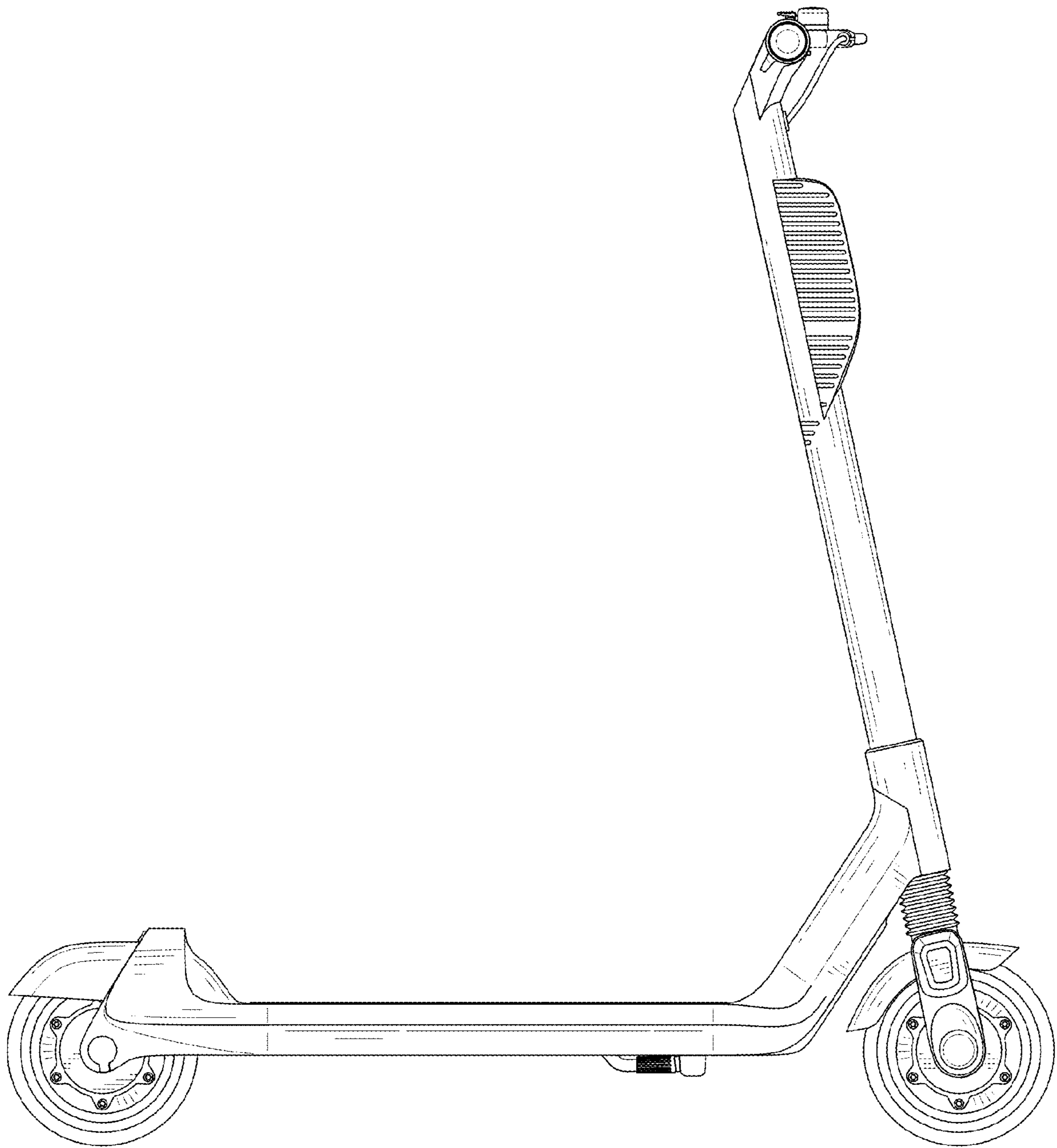

FIG. 5

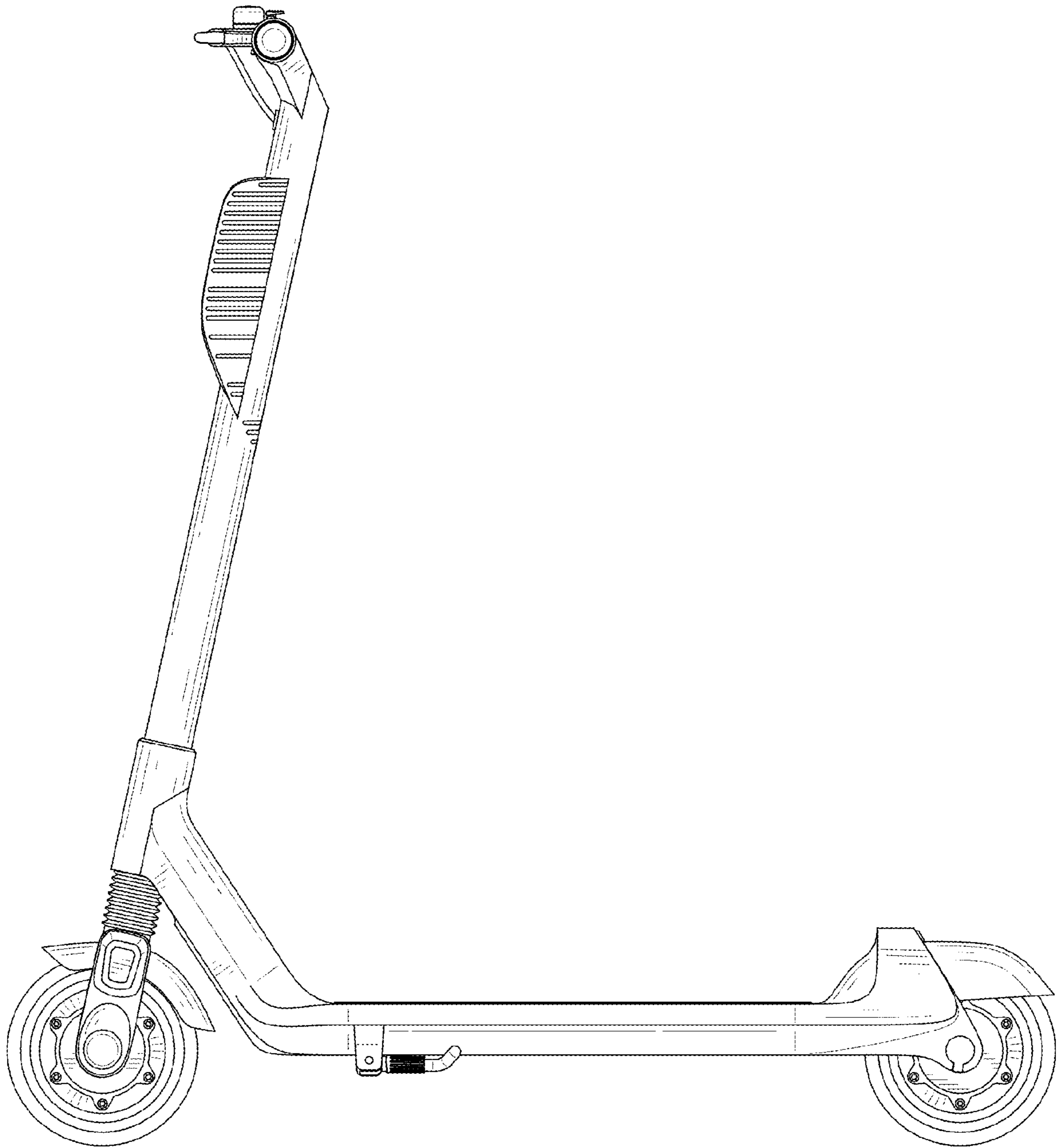

FIG. 6

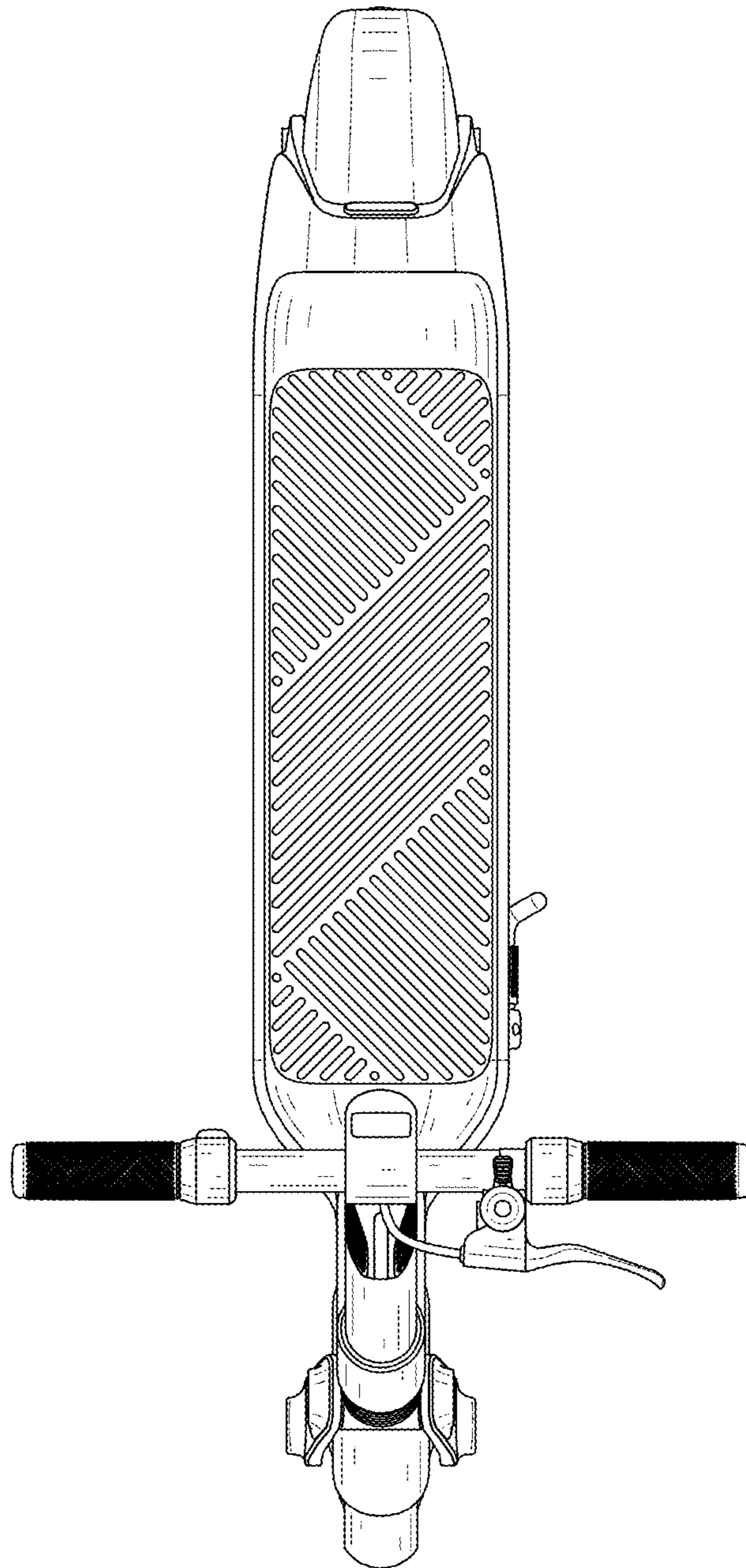

FIG. 7



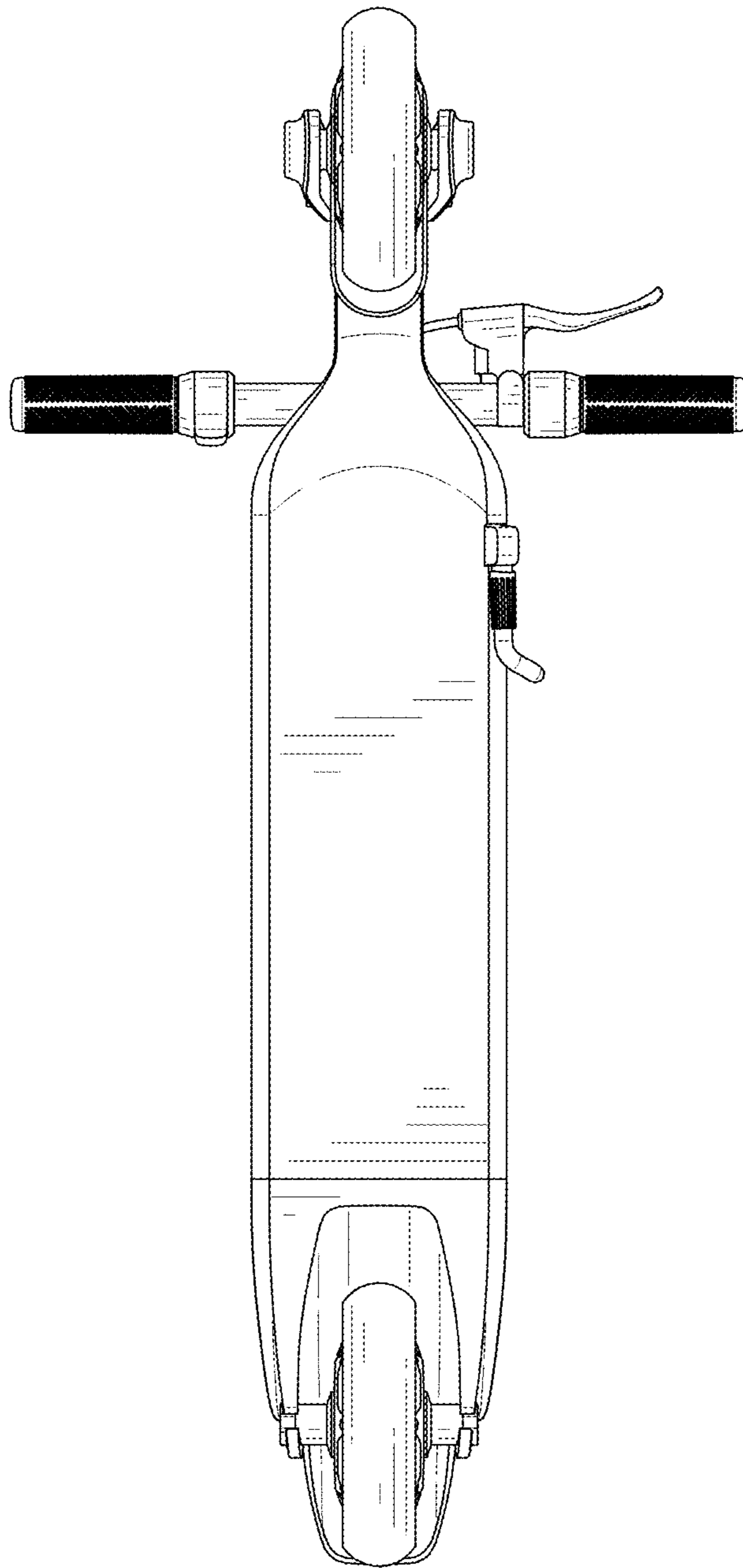

FIG. 8

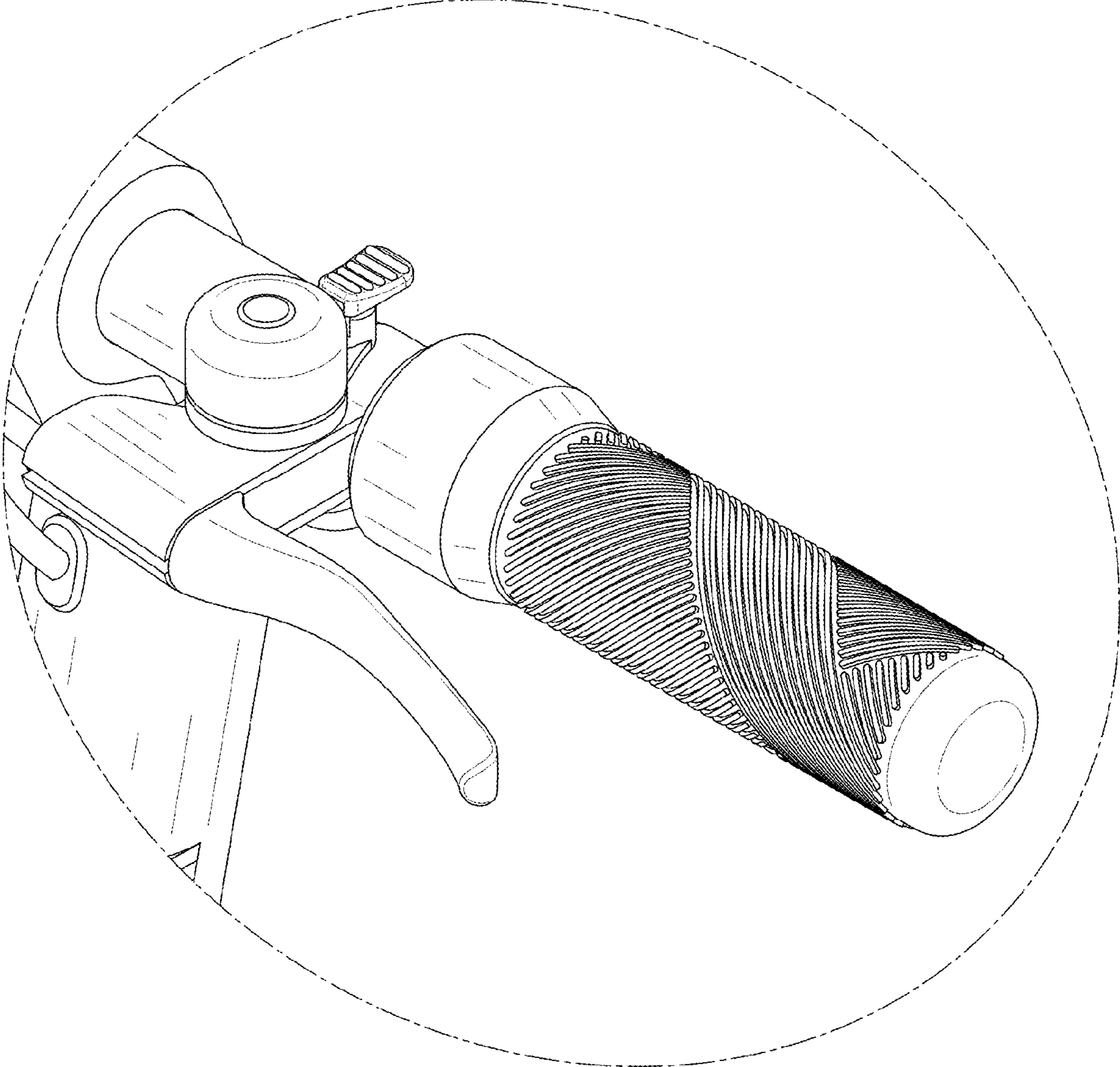

FIG. 9

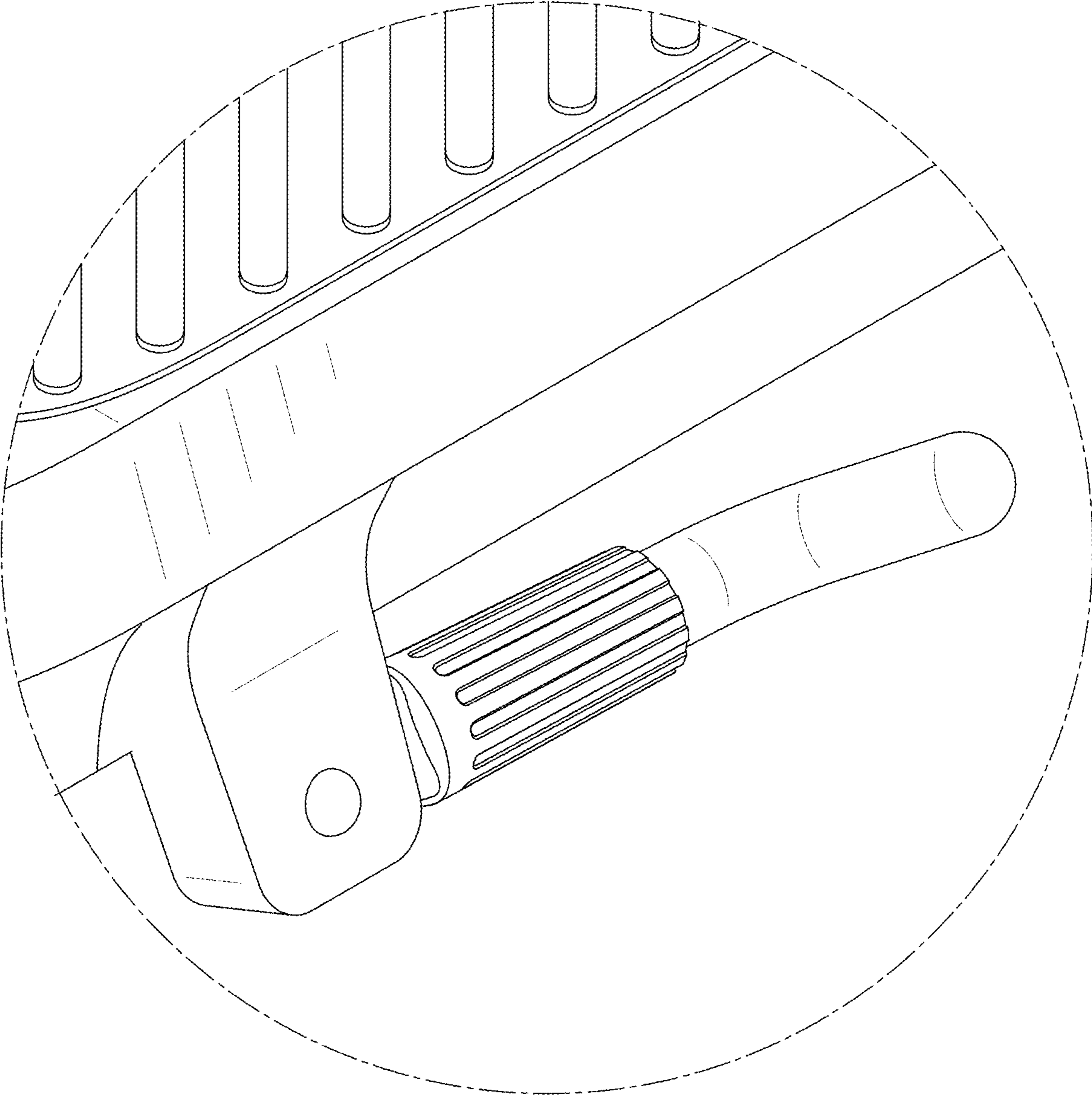

FIG. 10

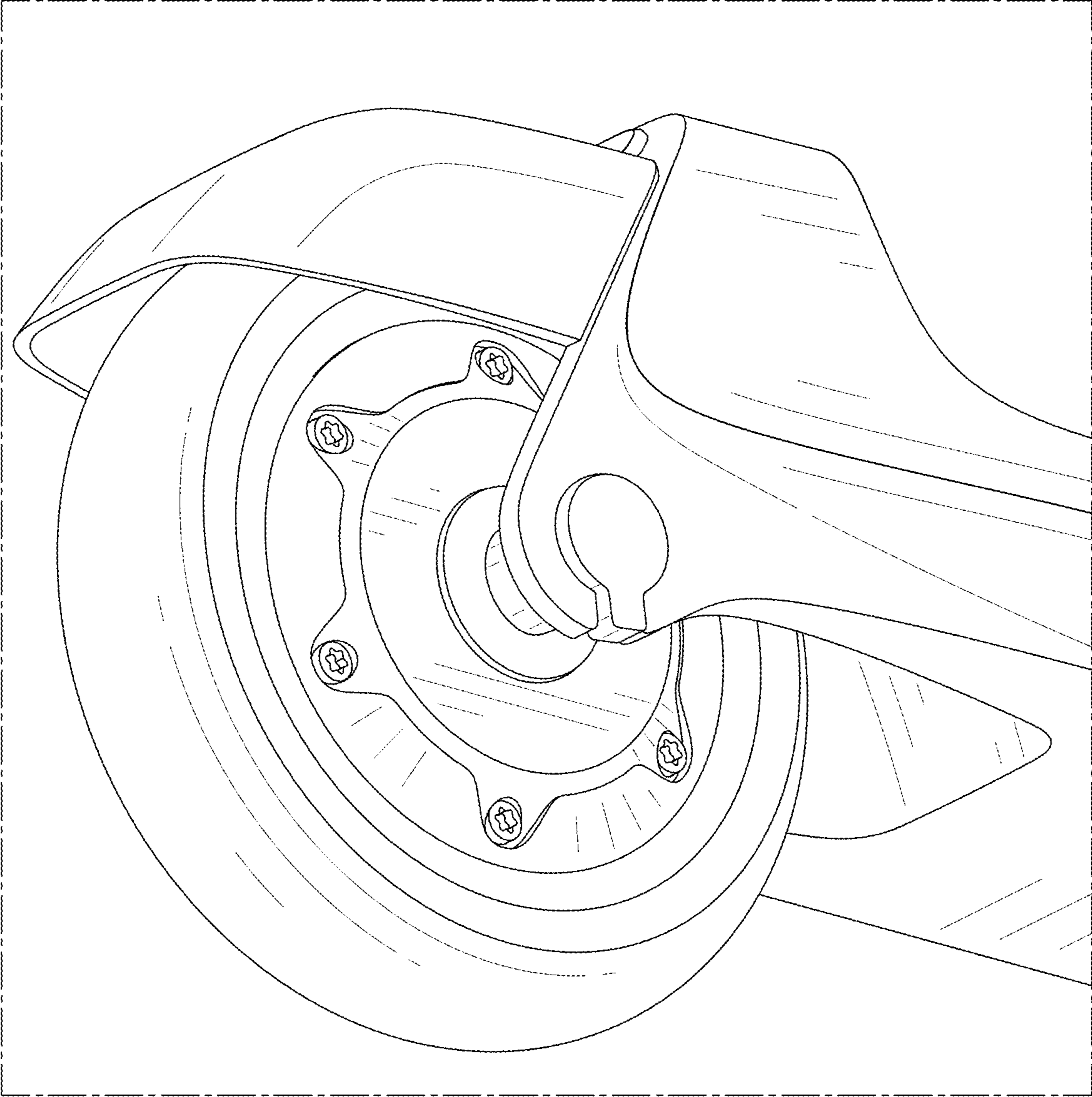

FIG. 11

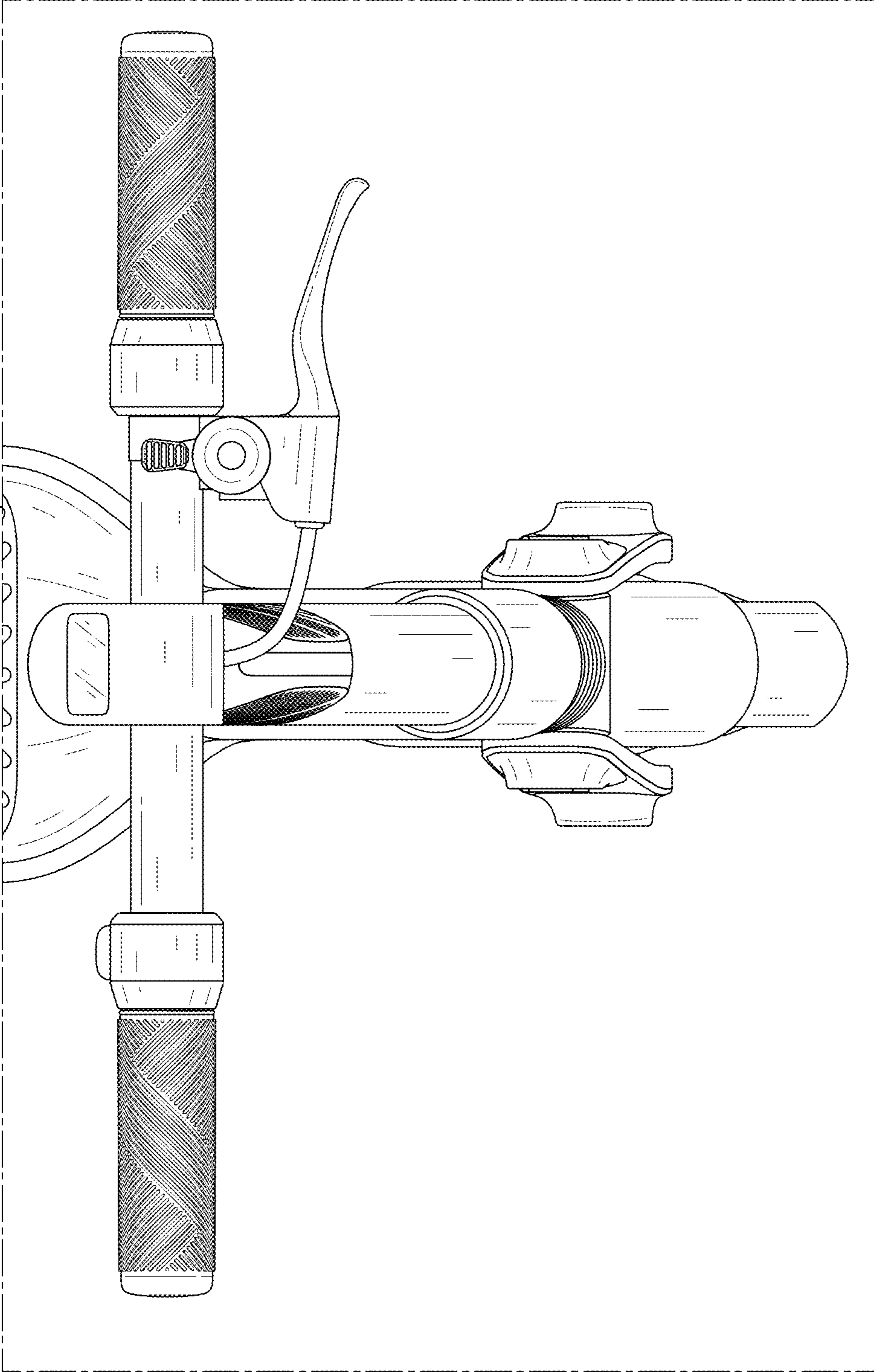

FIG. 12