



US00D918144S

(12) **United States Design Patent** (10) **Patent No.:** **US D918,144 S**
Boehnke (45) **Date of Patent:** **** May 4, 2021**

(54) **DRIVE UNIT**

(71) Applicant: **Robert Bosch GmbH**, Stuttgart (DE)

(72) Inventor: **Kai Oliver Boehnke**, Bad Urach (DE)

(73) Assignee: **Robert Bosch GmbH**, Stuttgart (DE)

(**) Term: **15 Years**

(21) Appl. No.: **29/675,733**

(22) Filed: **Jan. 4, 2019**

(30) **Foreign Application Priority Data**

Jul. 5, 2018 (EM) 005433000

(51) **LOC (13) Cl.** **13-02**

(52) **U.S. Cl.**
USPC **D13/118**

(58) **Field of Classification Search**
USPC D13/112-118, 122, 184, 145, 147, 152;
D12/122, 124, 126
CPC B62M 6/00; B62M 6/40; H01H 21/00;
H01H 21/04; H01R 13/516; H01R
13/518; H01R 13/52; H01R 13/46; H01R
13/50;

(Continued)

(56) **References Cited**

U.S. PATENT DOCUMENTS

D259,872 S * 7/1981 Ramsey D12/126
5,749,429 A * 5/1998 Yamauchi B62M 6/45
180/206.4

(Continued)

Primary Examiner — Catherine S Posthauer

Assistant Examiner — Alison M Ofstun

(74) *Attorney, Agent, or Firm* — Maginot, Moore & Beck
LLP

(57) **CLAIM**

The ornamental design for a drive unit, as shown and described.

DESCRIPTION

Cross reference is made to copending U.S. design patent application Ser. No. 29/675,728 entitled “Drive Unit” by Boehnke, Kai Oliver, which was filed on even date herewith; U.S. design patent application Ser. No. 29/675,730 entitled “Drive Unit” by Boehnke, Kai Oliver, which was filed on even date herewith; and U.S. design patent application Ser. No. 29/675,735 entitled “Drive Unit” by Boehnke, Kai Oliver, which was filed on even date herewith.

FIG. 1 is a perspective view of a first embodiment of a drive unit showing my new design;

FIG. 2 is a top plan view of the drive unit of FIG. 1;

FIG. 3 is a bottom plan view of the drive unit of FIG. 1;

FIG. 4 is a front elevational view of the drive unit of FIG. 1;

FIG. 5 is a rear elevational view of the drive unit of FIG. 1;

FIG. 6 is a left side elevational view of the drive unit of FIG. 1; and

FIG. 7 is a right side elevational view of the drive unit of FIG. 1.

FIG. 8 is a perspective view of a second embodiment of a drive unit showing my new design;

FIG. 9 is a top plan view of the drive unit of FIG. 8;

FIG. 10 is a bottom plan view of the drive unit of FIG. 8;

FIG. 11 is a front elevational view of the drive unit of FIG. 8;

FIG. 12 is a rear elevational view of the drive unit of FIG. 8;

FIG. 13 is a left side elevational view of the drive unit of FIG. 8; and,

FIG. 14 is a right side elevational view of the drive unit of FIG. 8.

In the drawings, the claimed design extends to the broken lines, and the broken lines form no part of the claimed design.

1 Claim, 14 Drawing Sheets

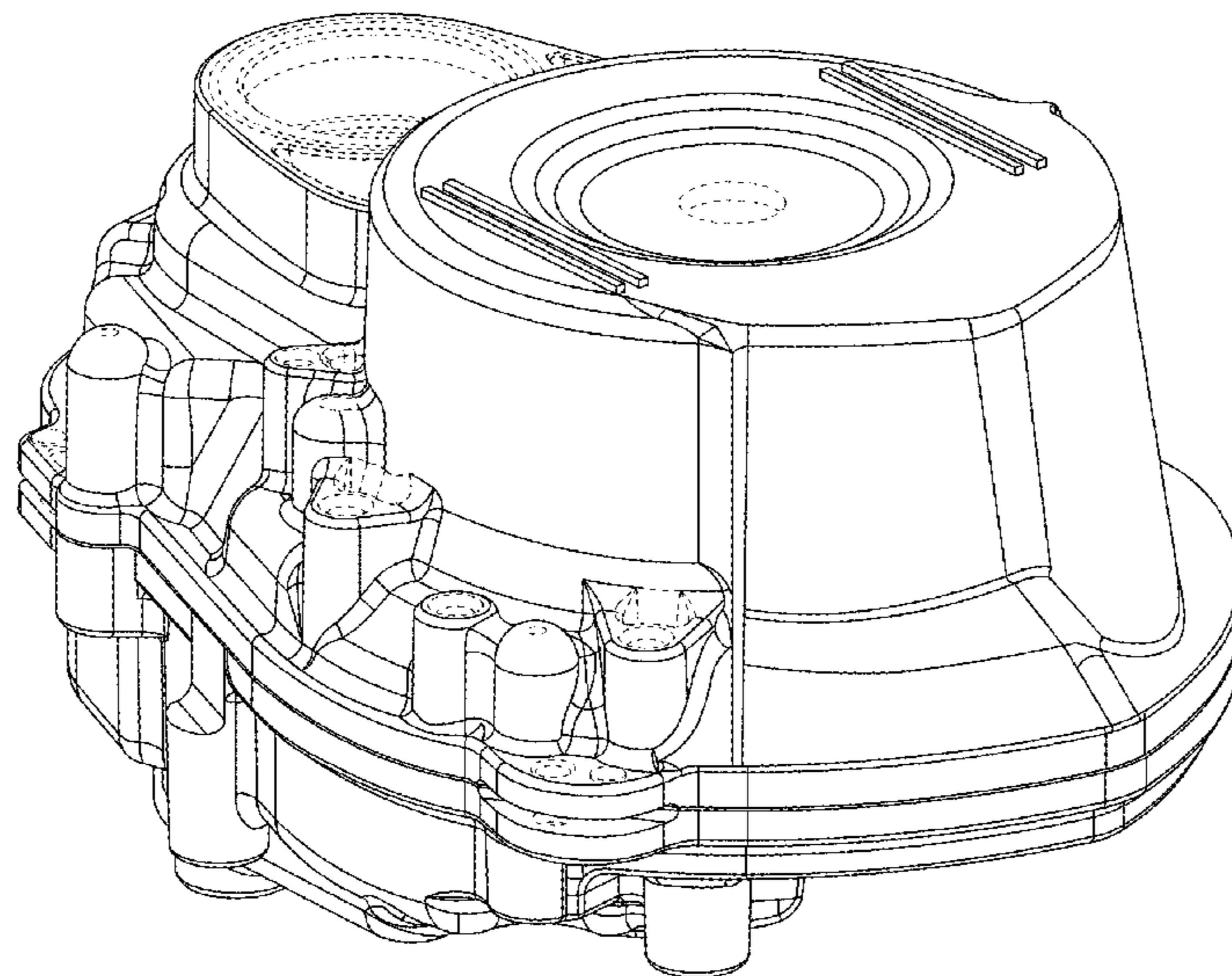

- (58) **Field of Classification Search**
CPC . H01R 13/506; H01R 13/5213; H01R 25/006
See application file for complete search history.

(56) **References Cited**

U.S. PATENT DOCUMENTS

5,845,727 A * 12/1998 Miyazawa B62M 6/55
180/206.4
6,012,538 A * 1/2000 Sonobe B62M 6/45
180/206.3
D697,478 S * 1/2014 Dasbach D13/112
D804,367 S * 12/2017 Greiner D12/123
9,969,303 B2 * 5/2018 Ta B60N 2/0232
9,981,716 B2 * 5/2018 Suzuki B62M 6/55
10,036,465 B2 * 7/2018 Watarai B62M 6/55
10,359,108 B1 * 7/2019 Ramirez Ortiz F16B 21/073
2016/0288872 A1 * 10/2016 Shahana B62K 25/286
2016/0375956 A1 * 12/2016 Talavasek B62K 11/04
180/220
2018/0017152 A1 * 1/2018 Emura B62K 25/286
2018/0178883 A1 * 6/2018 Ichida B62L 3/00

* cited by examiner

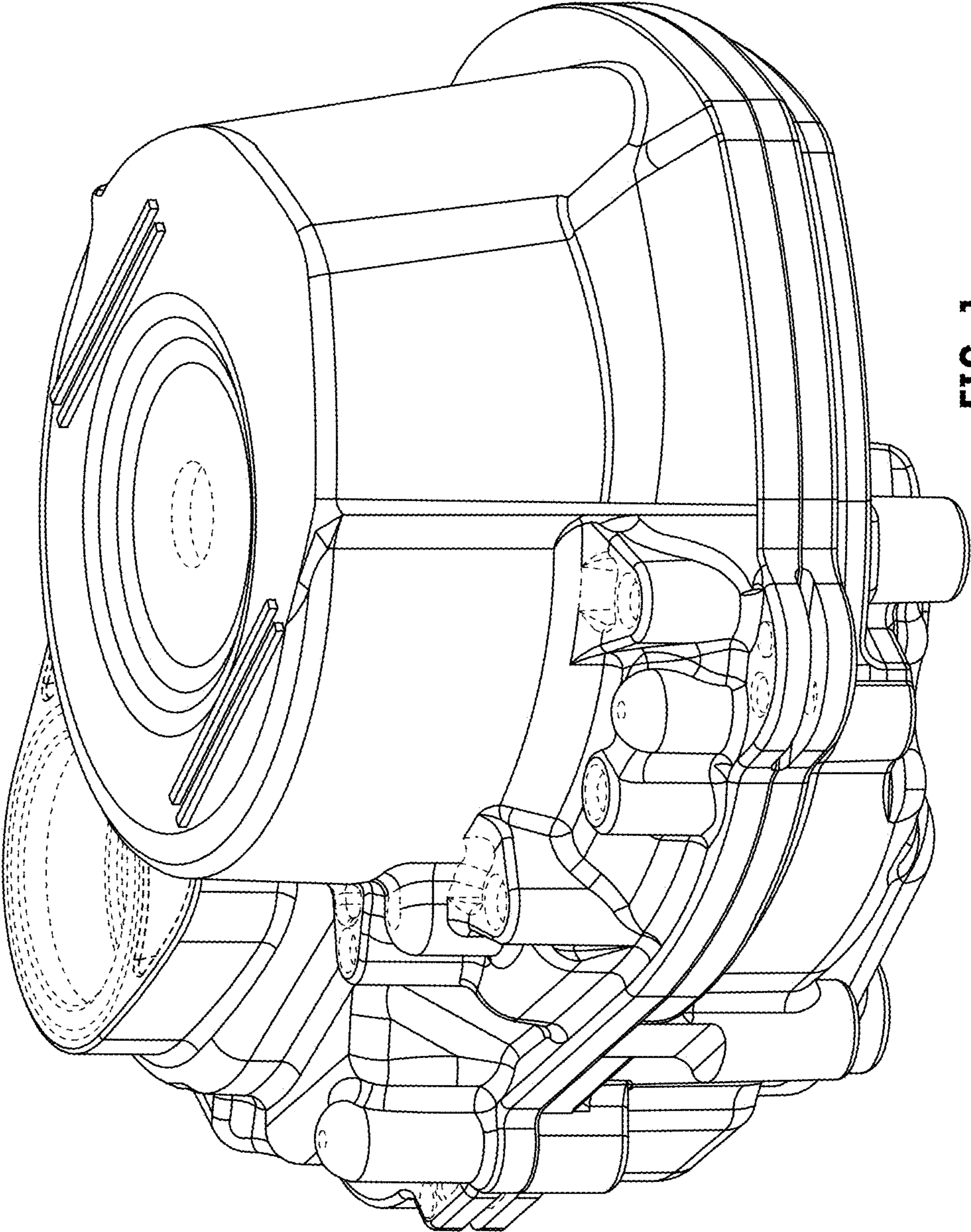

FIG. 1

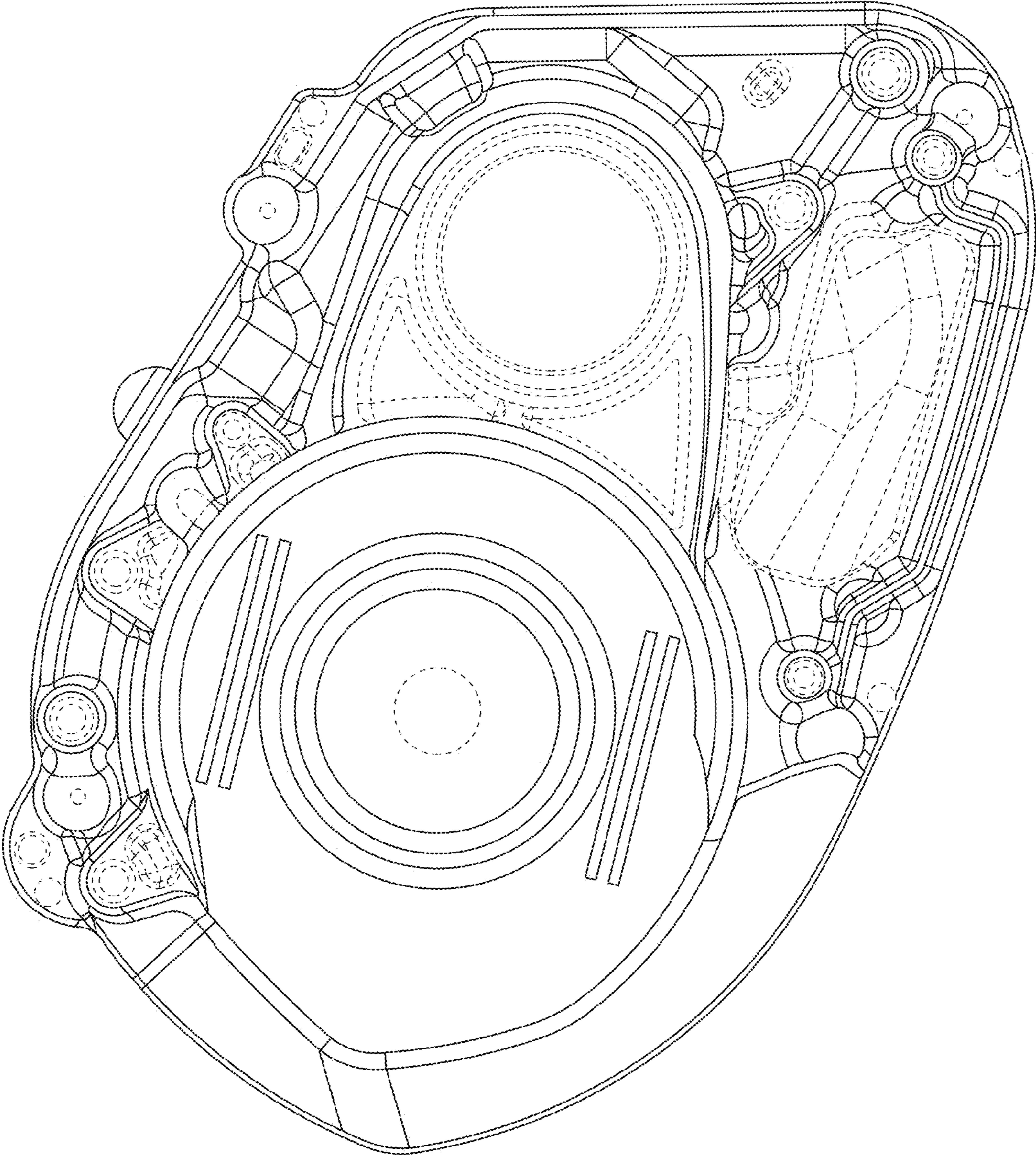

FIG. 2

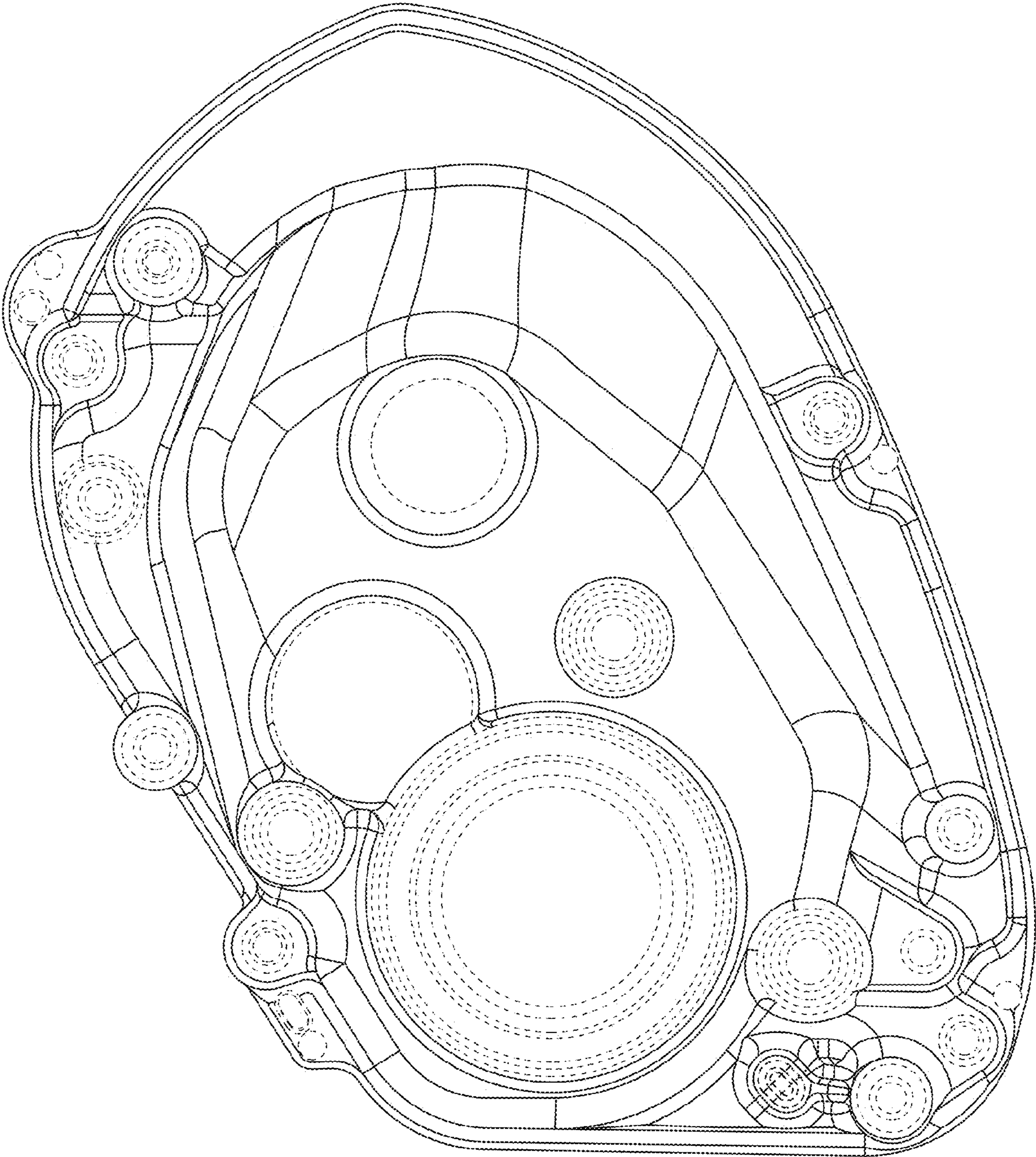

FIG. 3

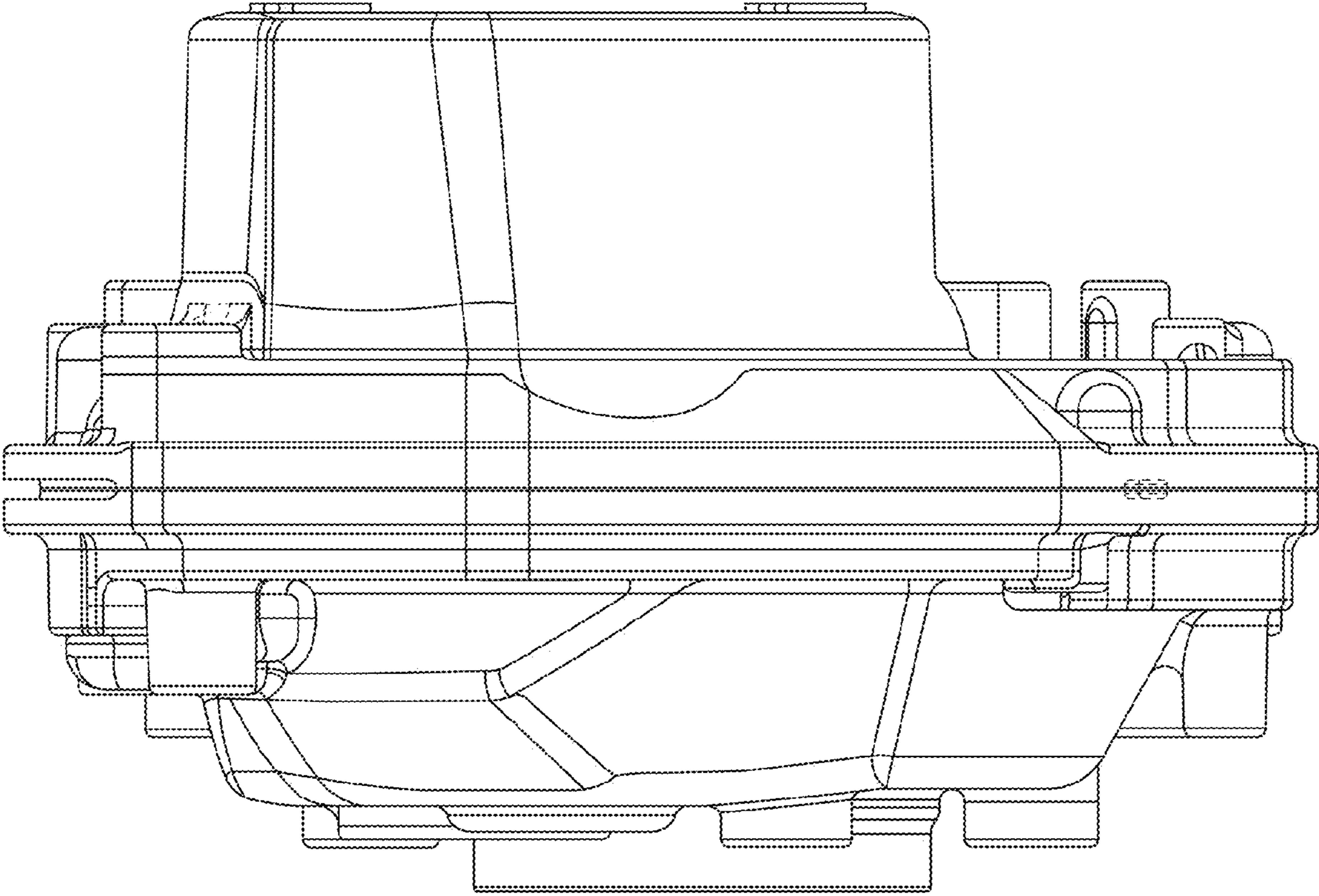

FIG. 4

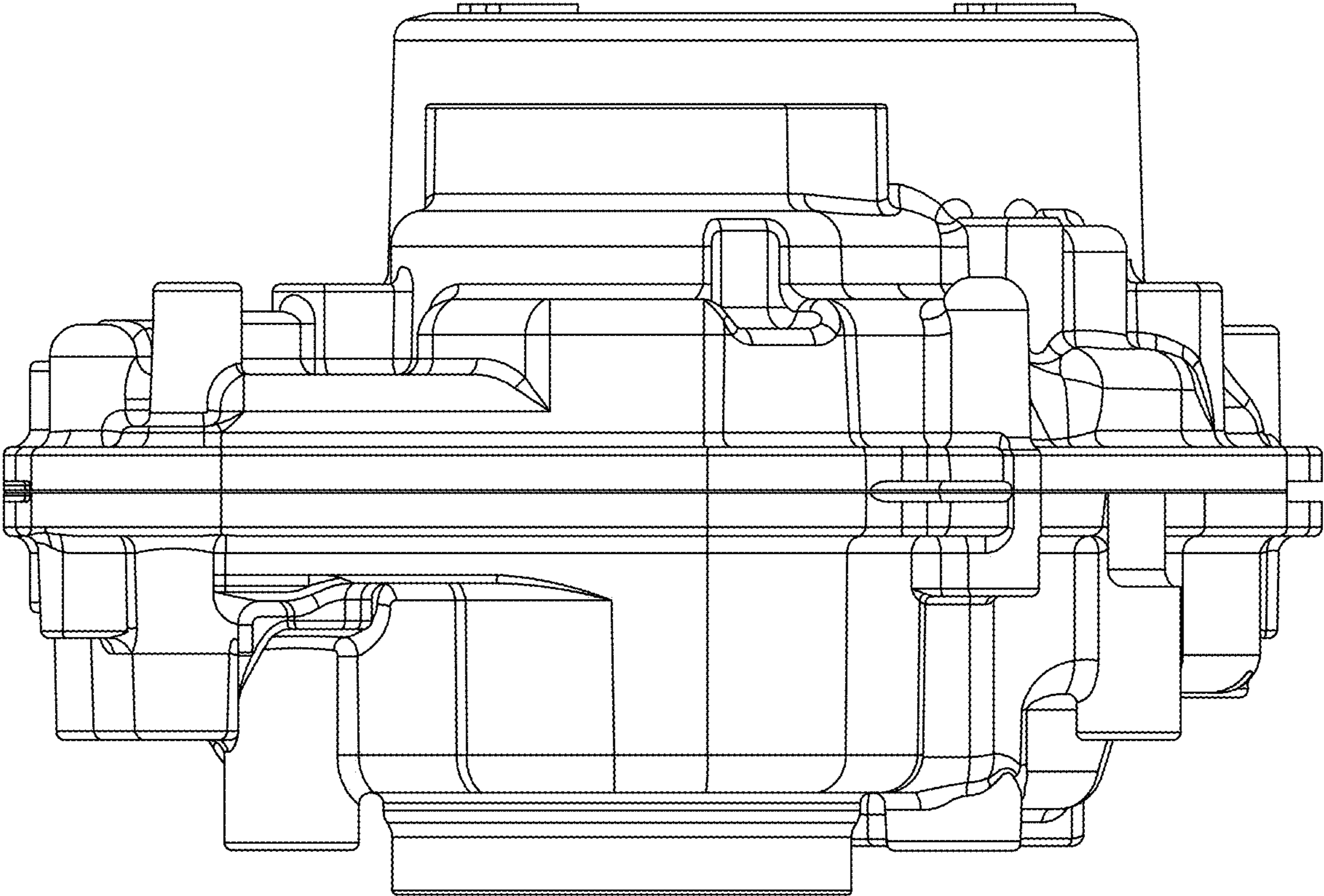

FIG. 5

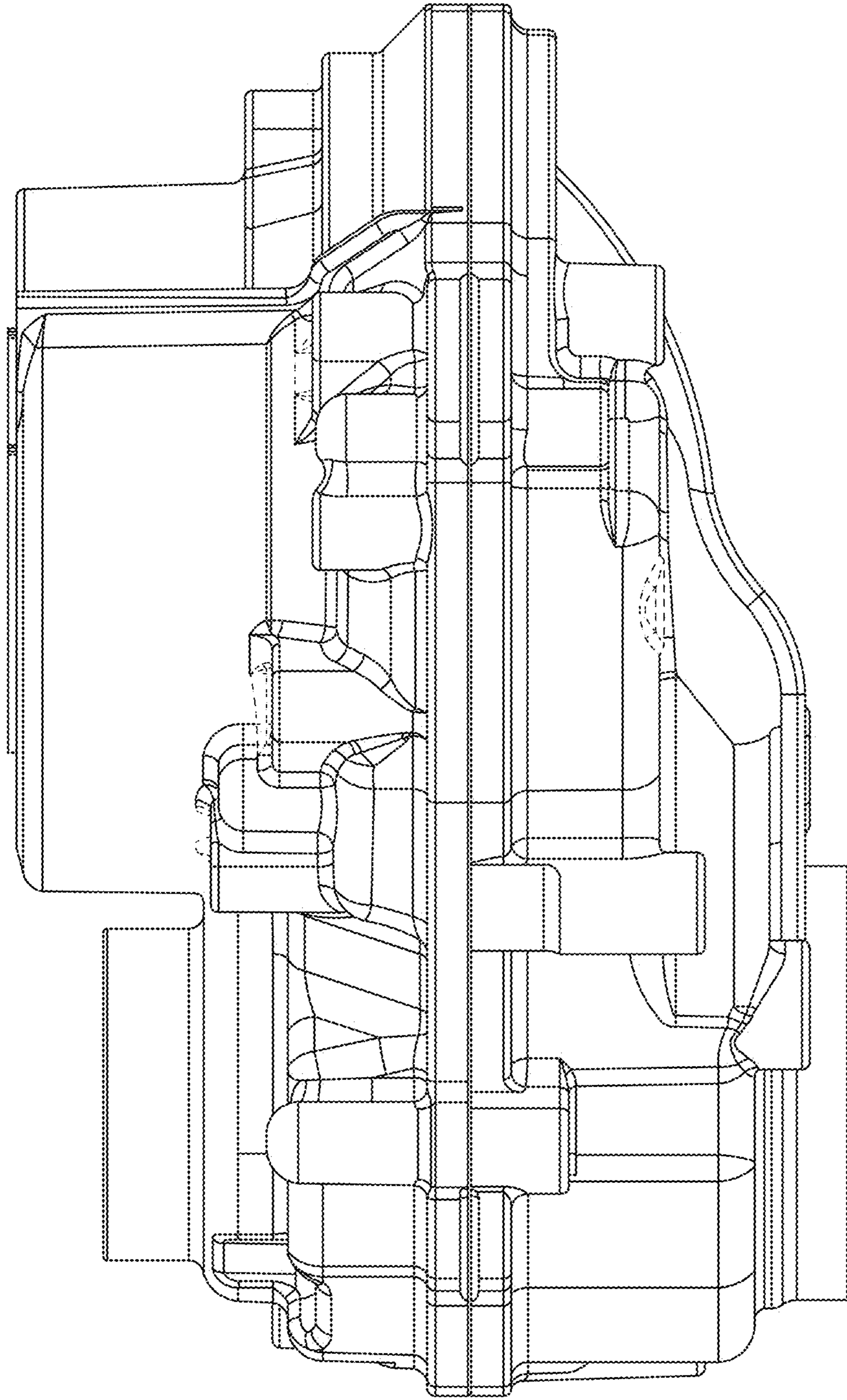

FIG. 6

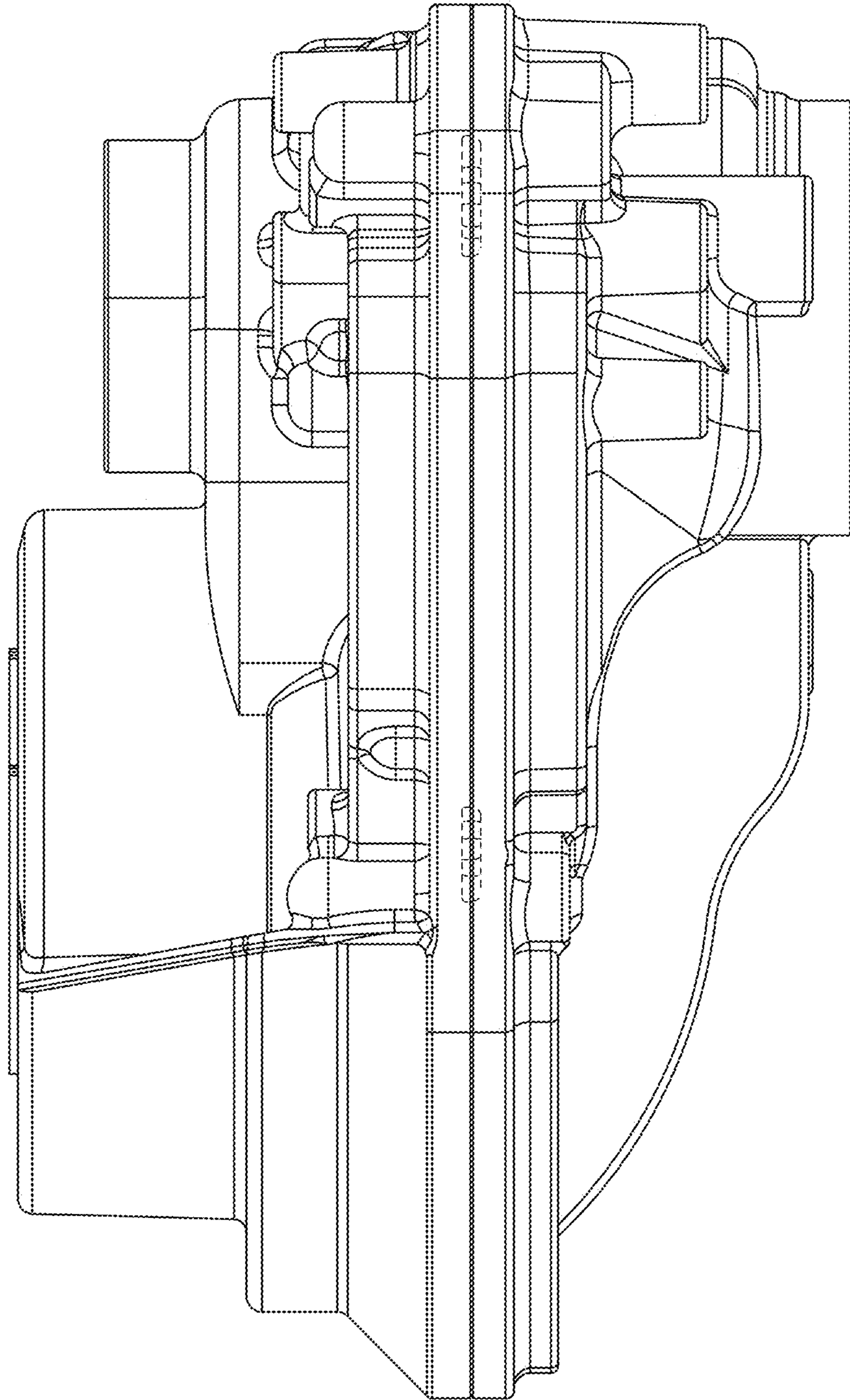

FIG. 7

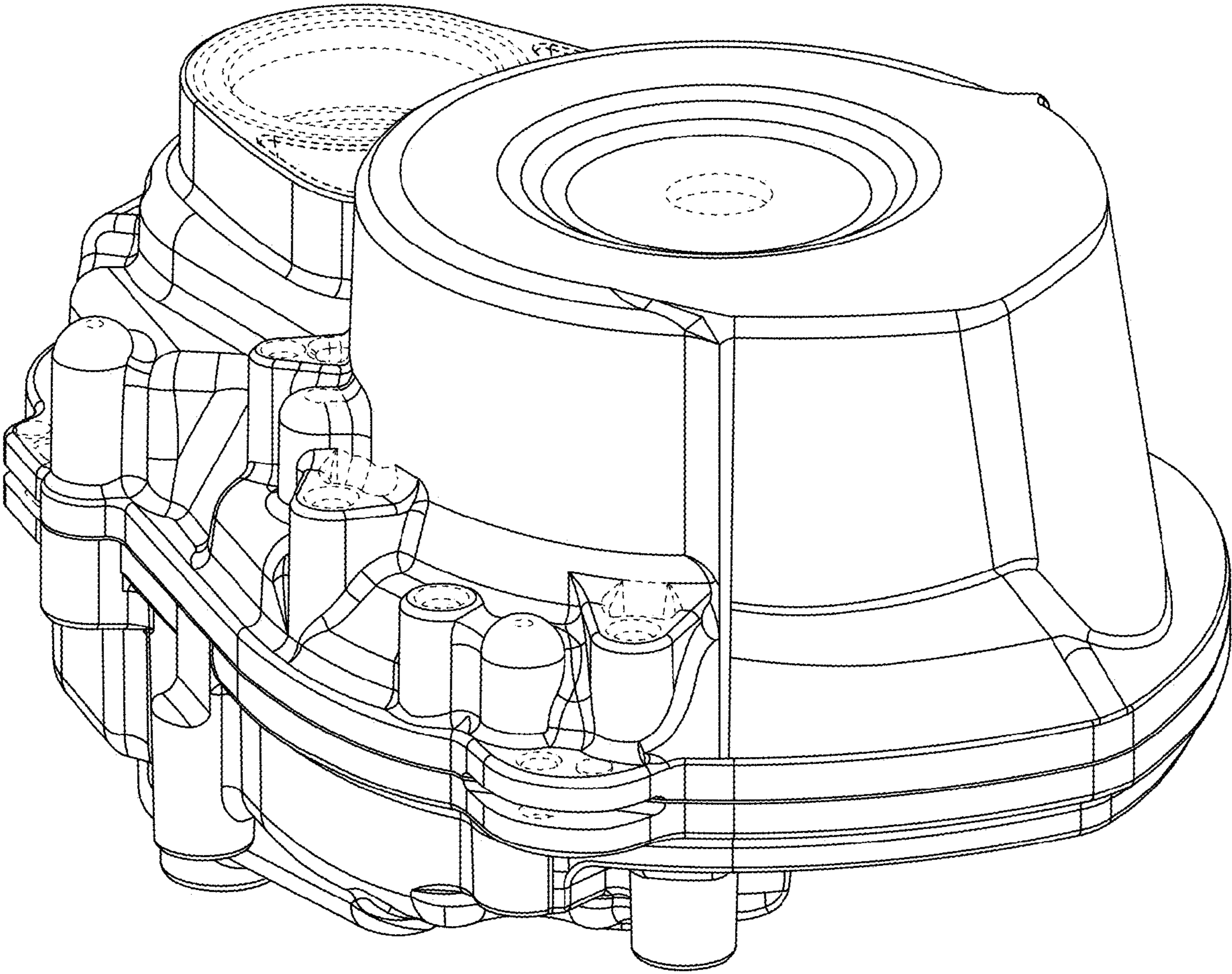

FIG. 8

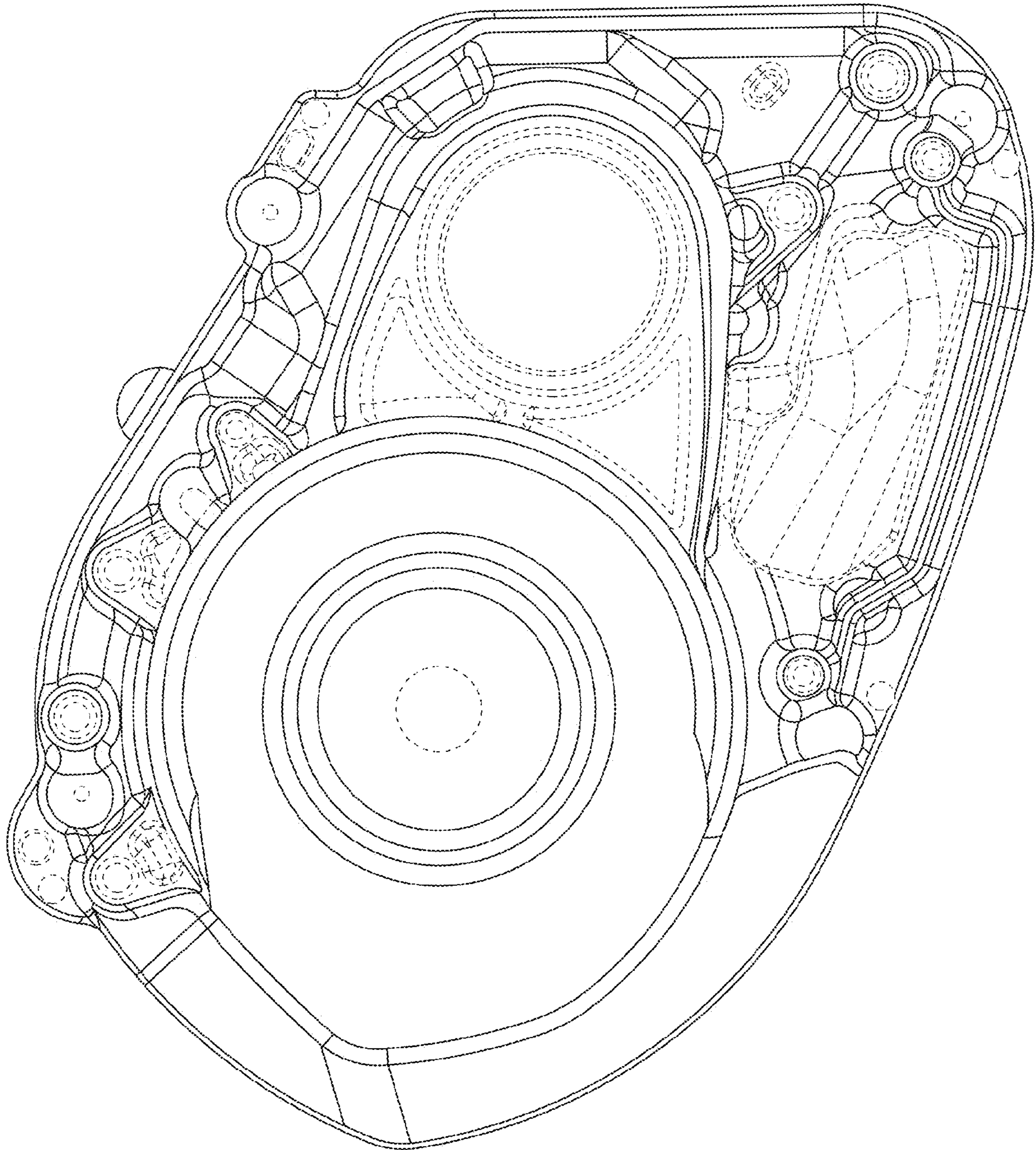

FIG. 9

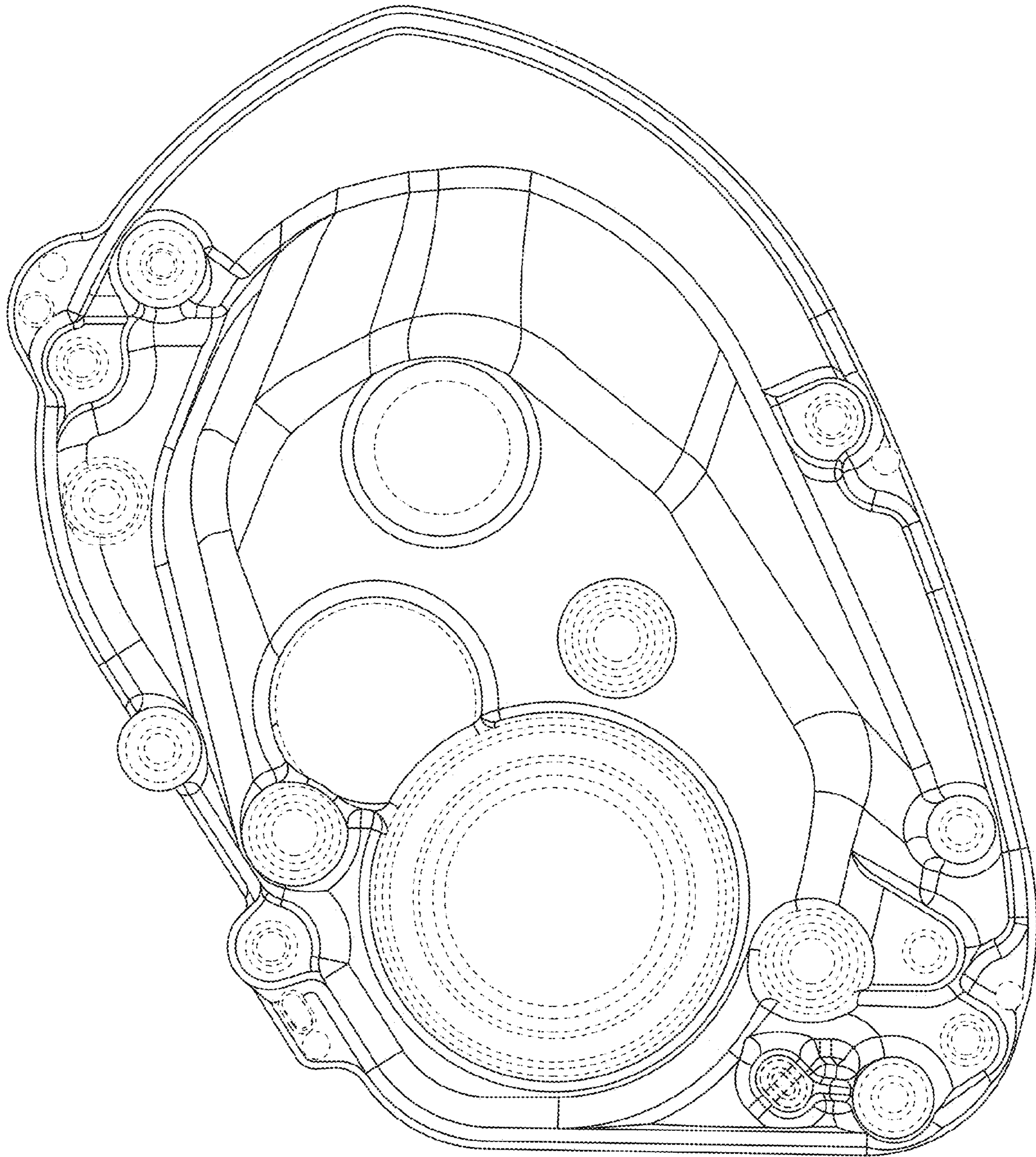

FIG. 10

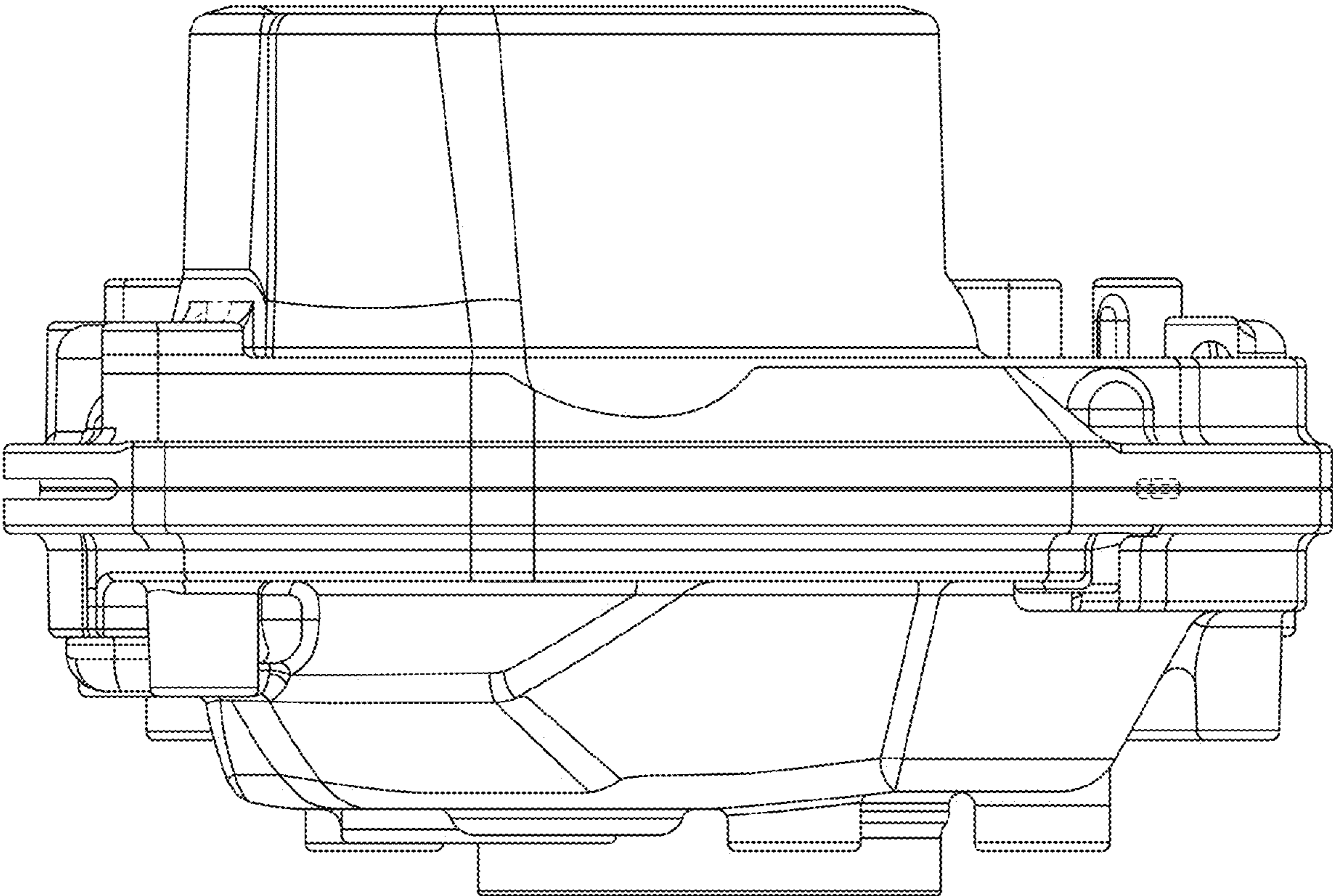

FIG. 11

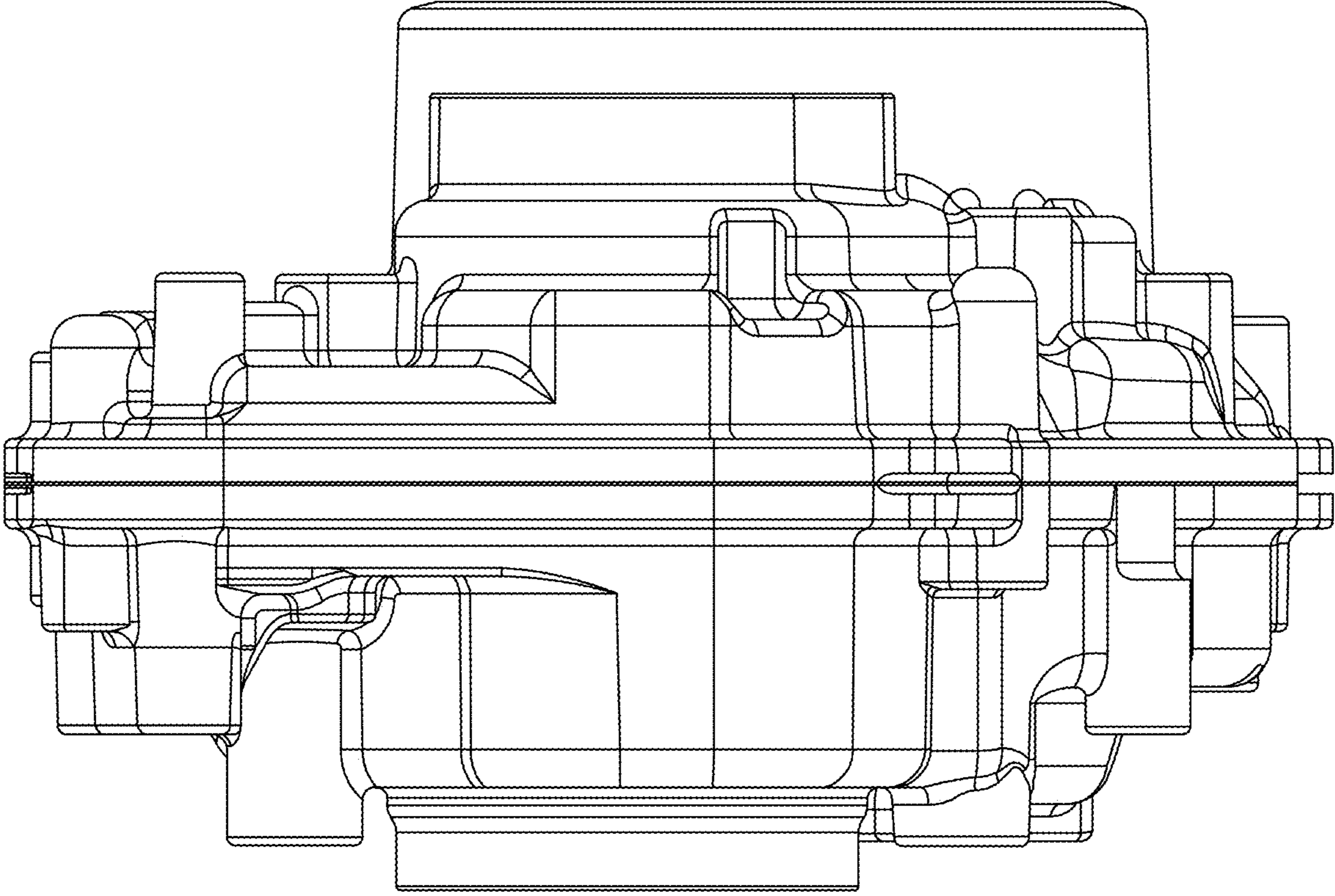

FIG. 12

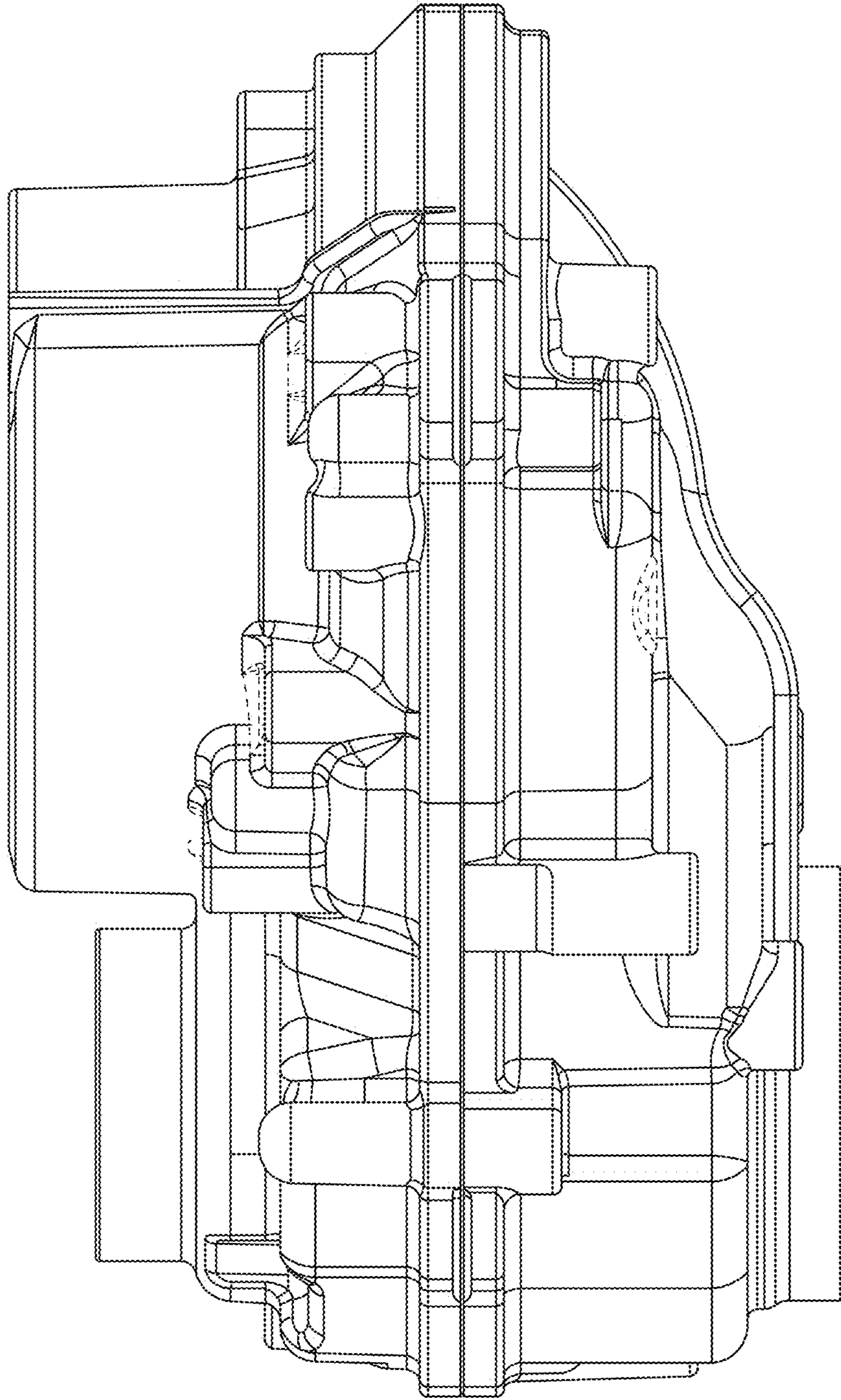

FIG. 13

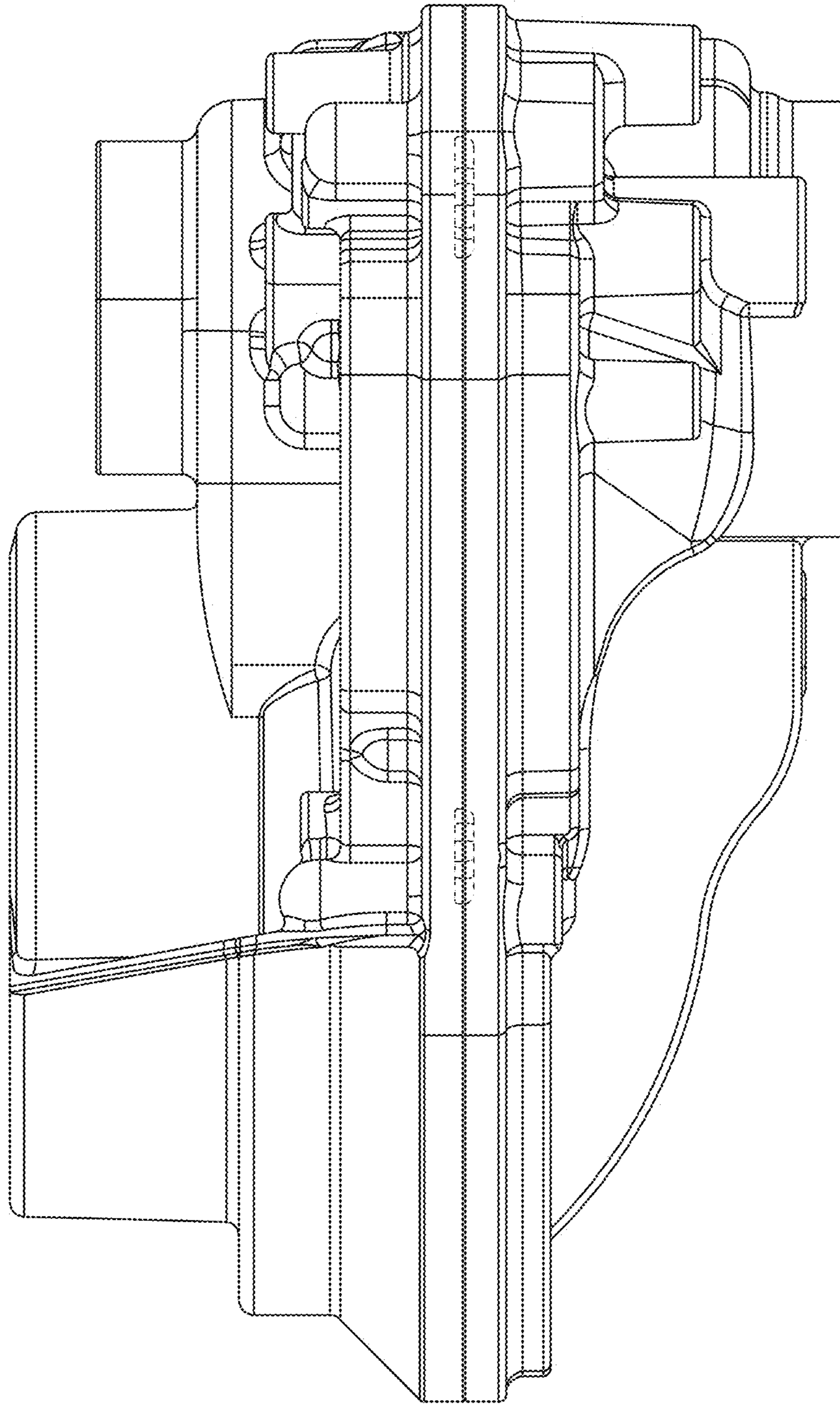

FIG. 14