



US00D918141S

(12) **United States Design Patent**  
**König et al.**

(10) **Patent No.:** **US D918,141 S**

(45) **Date of Patent:** **\*\* May 4, 2021**

(54) **ELECTRIC MOTOR**

(71) Applicant: **SIEMENS**  
**AKTIENGESELLSCHAFT**, Munich  
(DE)

(72) Inventors: **Martin König**, Fladungen (DE); **Tobias**  
**Wehner**, Zahlbach (DE); **Martin**  
**Winter**, Bad Bocklet (DE)

(73) Assignee: **Siemens Aktiengesellschaft**, Munich  
(DE)

(\*\*) Term: **15 Years**

(21) Appl. No.: **29/674,585**

(22) Filed: **Dec. 21, 2018**

(30) **Foreign Application Priority Data**

Jun. 22, 2018 (EM) ..... 005321791

(51) **LOC (13) Cl.** ..... **13-01**

(52) **U.S. Cl.**  
USPC ..... **D13/112**

(58) **Field of Classification Search**  
USPC ..... D15/1-5, 148; D13/112-114, 122, 184  
CPC ..... B60L 9/00; B60L 9/02; B60L 9/16; B60L  
9/32; B60L 9/005; B60L 1/00; B60L  
58/12; H02K 1/82; H02K 26/00; H02K  
5/22; H02K 5/18; H02K 11/00; H02K  
15/00; H02K 15/14; H02K 15/16; H02K  
19/06; H02K 9/00; H02K 3/50; H02K  
1/16; H02K 5/161

See application file for complete search history.

(56) **References Cited**

**U.S. PATENT DOCUMENTS**

D207,401 S \* 4/1967 Andrews ..... D13/114  
D236,005 S \* 7/1975 Baumann ..... D13/114

D236,985 S \* 9/1975 Baumann ..... D13/114  
D245,499 S \* 8/1977 Andreas ..... D13/112  
5,885,102 A \* 3/1999 Harting ..... H02K 5/225  
439/527  
D410,659 S \* 6/1999 Lannoch ..... D15/148  
D431,572 S \* 10/2000 Antony ..... D15/5  
D568,811 S \* 5/2008 Andersson ..... D13/112  
D568,812 S \* 5/2008 Andersson ..... D13/112  
D576,548 S \* 9/2008 Andersson ..... D13/112  
D576,941 S \* 9/2008 Evon ..... D13/112  
D618,615 S \* 6/2010 Basic ..... D13/114  
7,965,005 B2 \* 6/2011 Schmidt ..... H02K 5/06  
310/71  
8,278,790 B2 \* 10/2012 Rueggen ..... H02K 11/33  
310/68 D  
D707,629 S \* 6/2014 Cocks ..... D13/122  
D713,338 S \* 9/2014 Lannoch ..... D13/112  
D769,191 S \* 10/2016 Vohlgemuth ..... D13/114  
D772,814 S \* 11/2016 Rivault ..... D13/114  
D794,563 S \* 8/2017 Matta ..... D13/114

(Continued)

*Primary Examiner* — Sheryl Lane

*Assistant Examiner* — Mark T. Philipps

(74) *Attorney, Agent, or Firm* — Henry M. Feiereisen  
LLC

(57) **CLAIM**

The ornamental design for an electric motor, as shown and described.

**DESCRIPTION**

FIG. 1 is a front view of an electric motor, showing our new design;  
FIG. 2 is a rear view thereof;  
FIG. 3 is a top view thereof;  
FIG. 4 is a bottom view thereof;  
FIG. 5 is a right side view thereof;  
FIG. 6 is a left side view thereof; and,  
FIG. 7 is a top, front and right side perspective view thereof.  
The broken lines represent a portion of an electric motor and form no part of the claimed design;

**1 Claim, 7 Drawing Sheets**

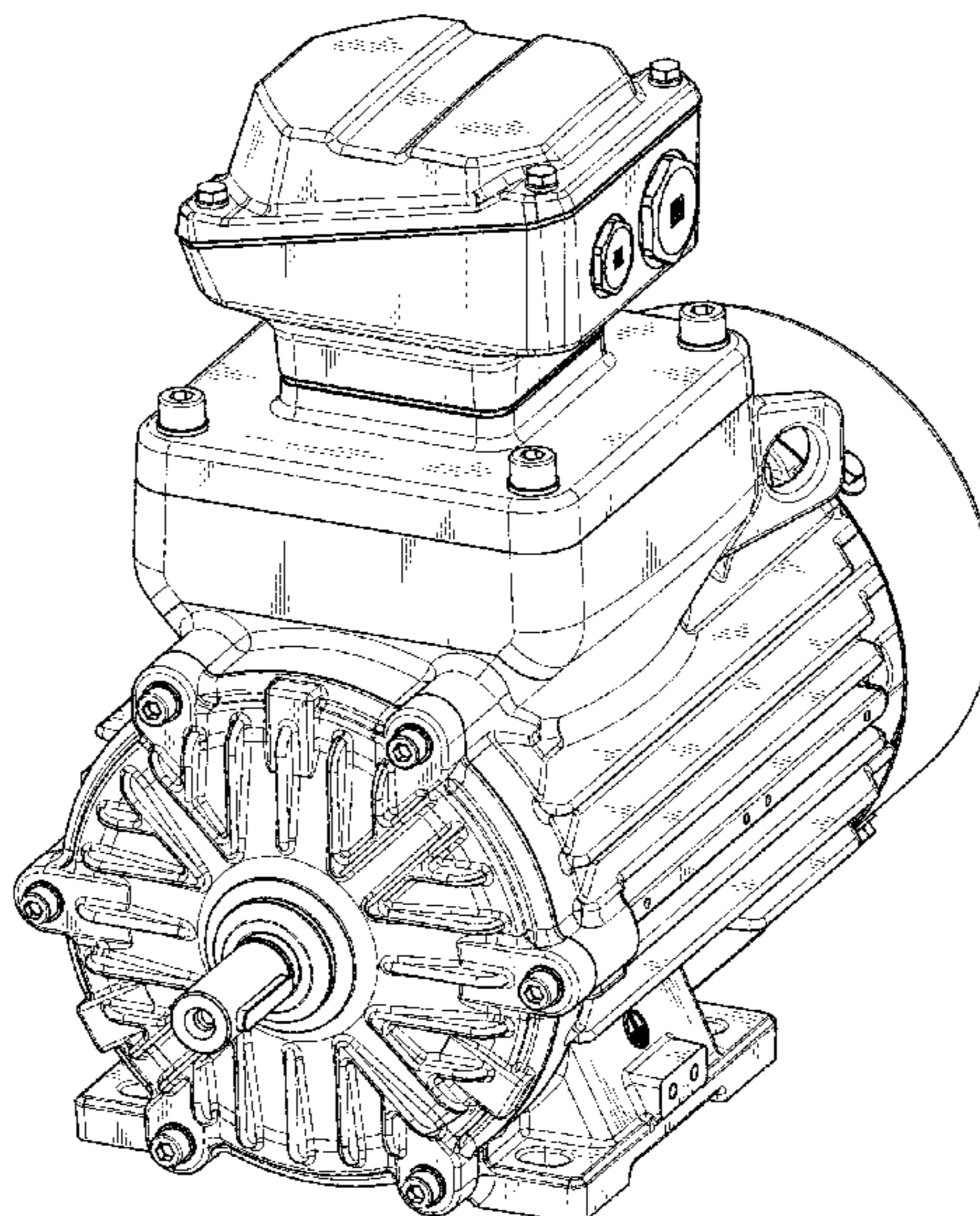

(56)

**References Cited**

U.S. PATENT DOCUMENTS

D801,925 S \* 11/2017 Andersson ..... D13/112  
D813,165 S \* 3/2018 Grillenberger ..... D13/112  
10,267,364 B2 \* 4/2019 Niedermeyer ..... F16C 33/6666  
D877,200 S \* 3/2020 Melde ..... D15/5  
2013/0106217 A1 \* 5/2013 Drye ..... H02K 9/14  
310/89  
2014/0140872 A1 \* 5/2014 Stork ..... F04B 17/03  
417/410.1  
2017/0310192 A1 \* 10/2017 Cezario ..... H02K 5/10  
2018/0358860 A1 \* 12/2018 Major ..... H02K 5/10

\* cited by examiner

FIG. 1

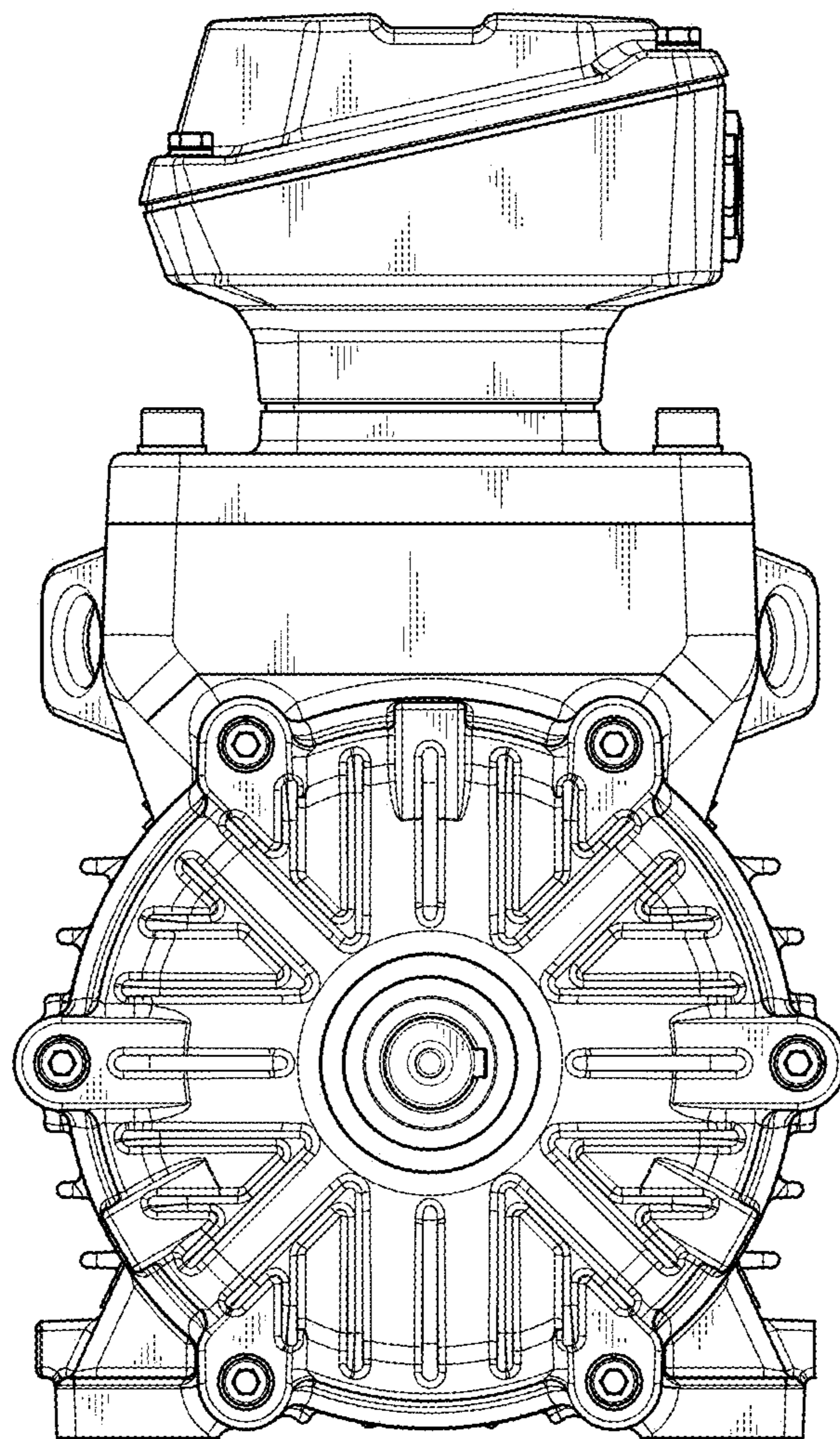



FIG. 2

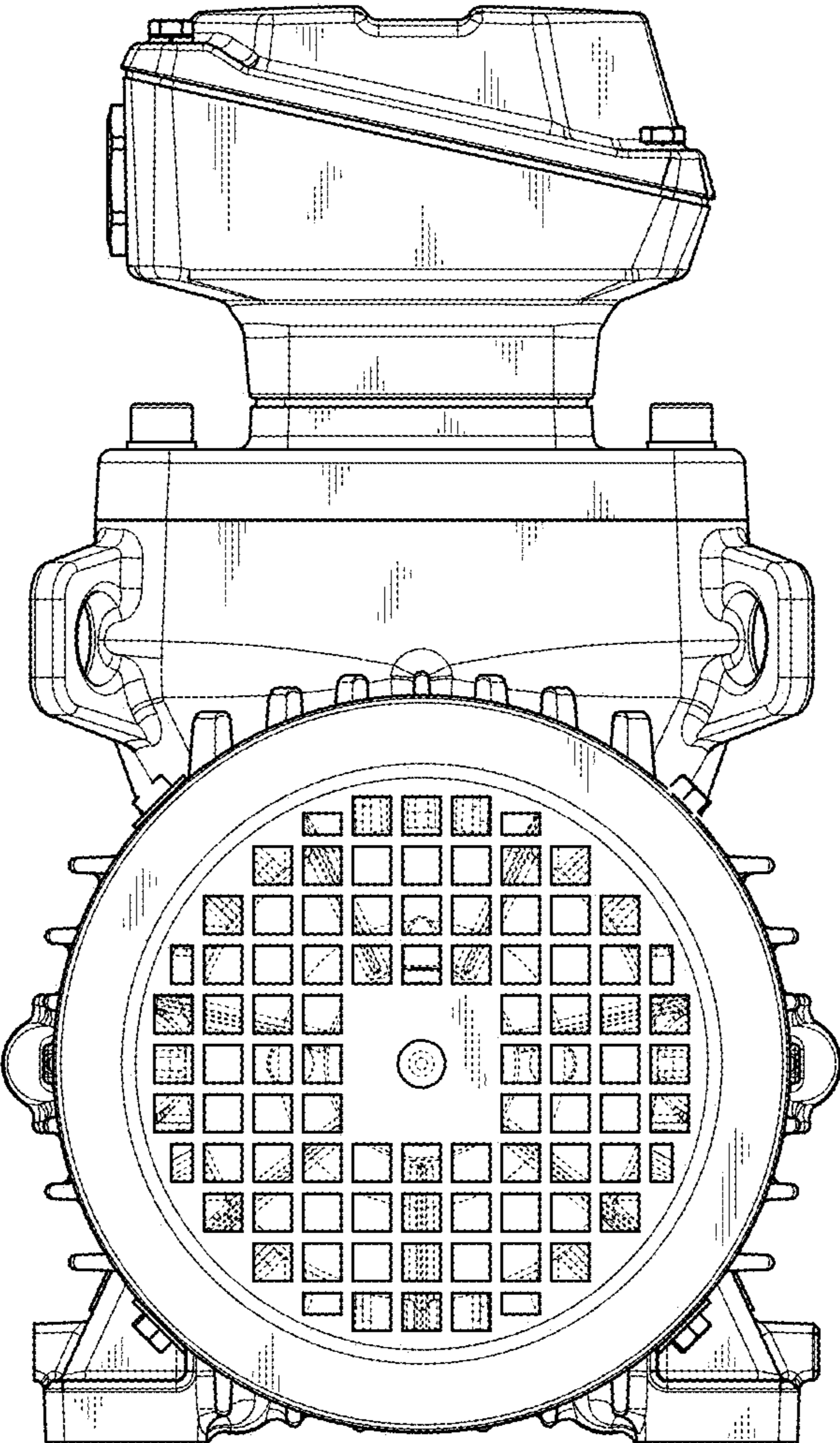

FIG. 3

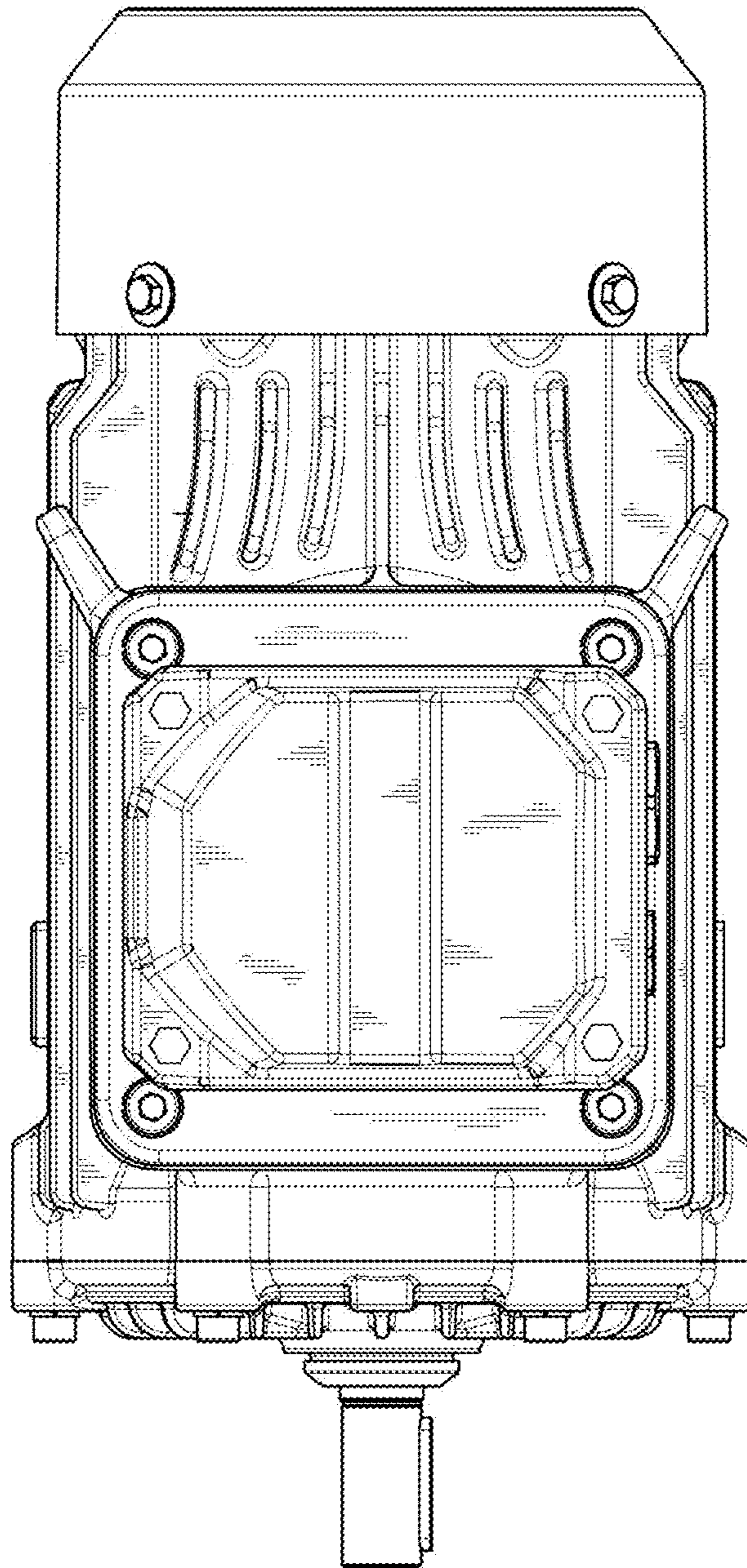

FIG. 4

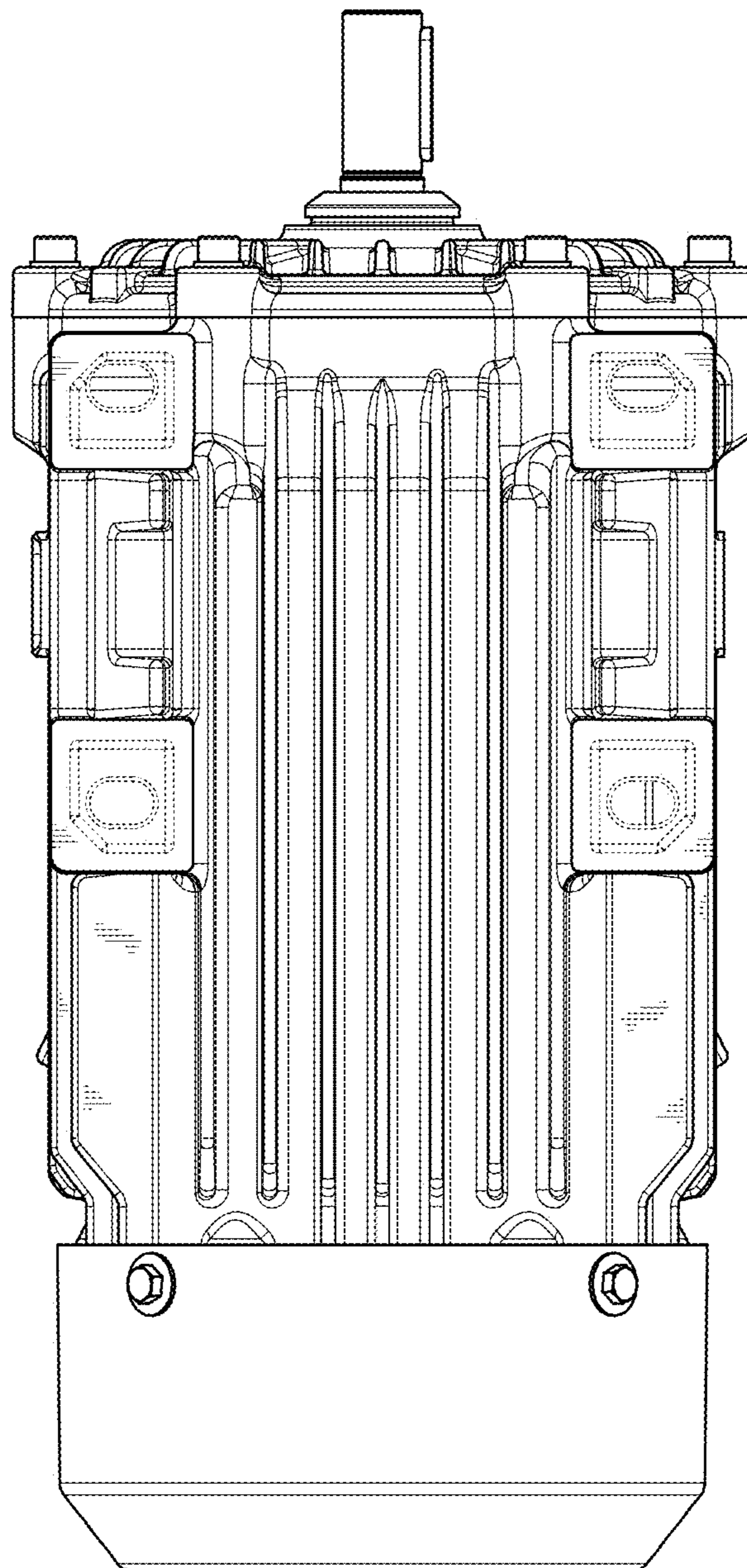

FIG. 5

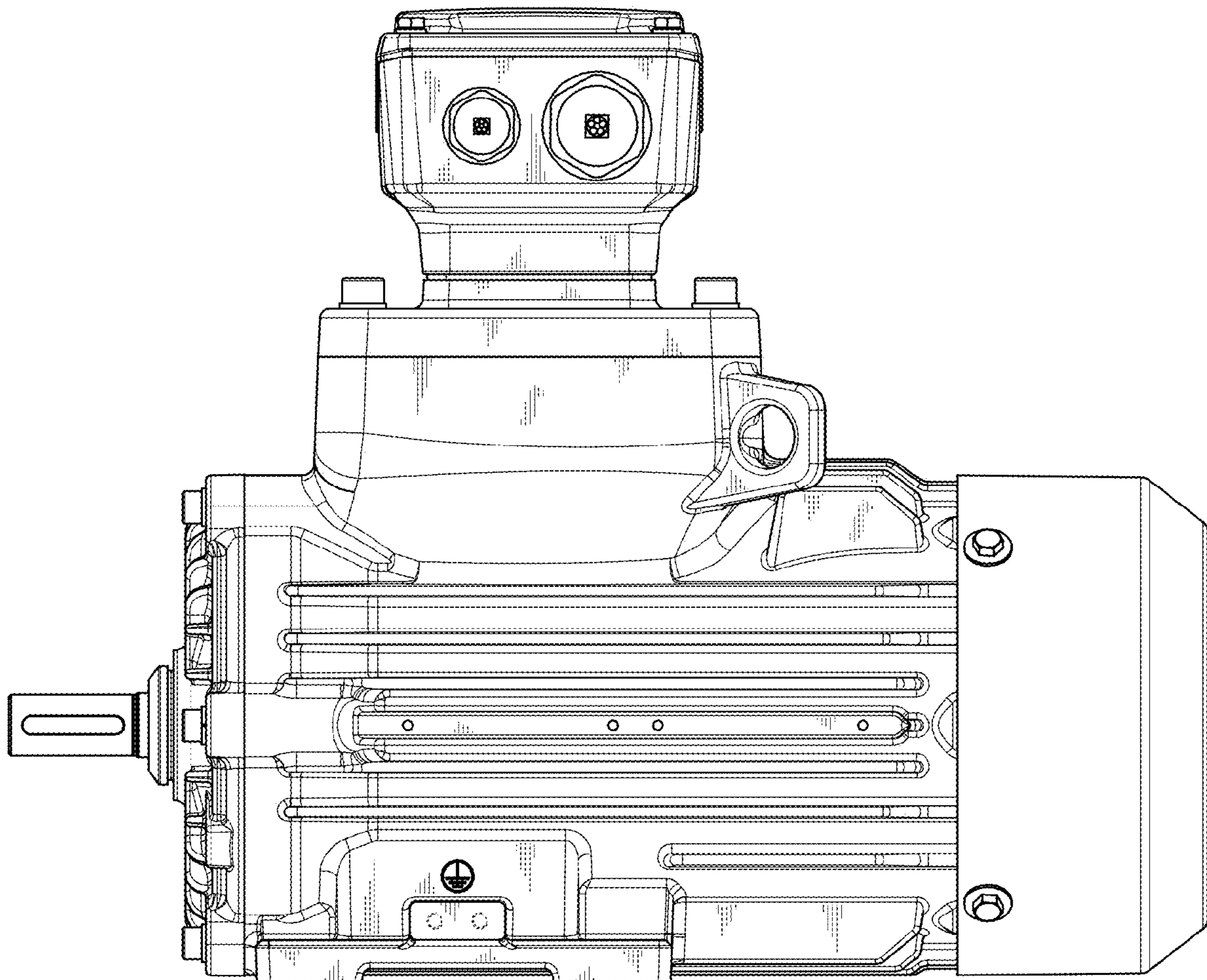



FIG. 6

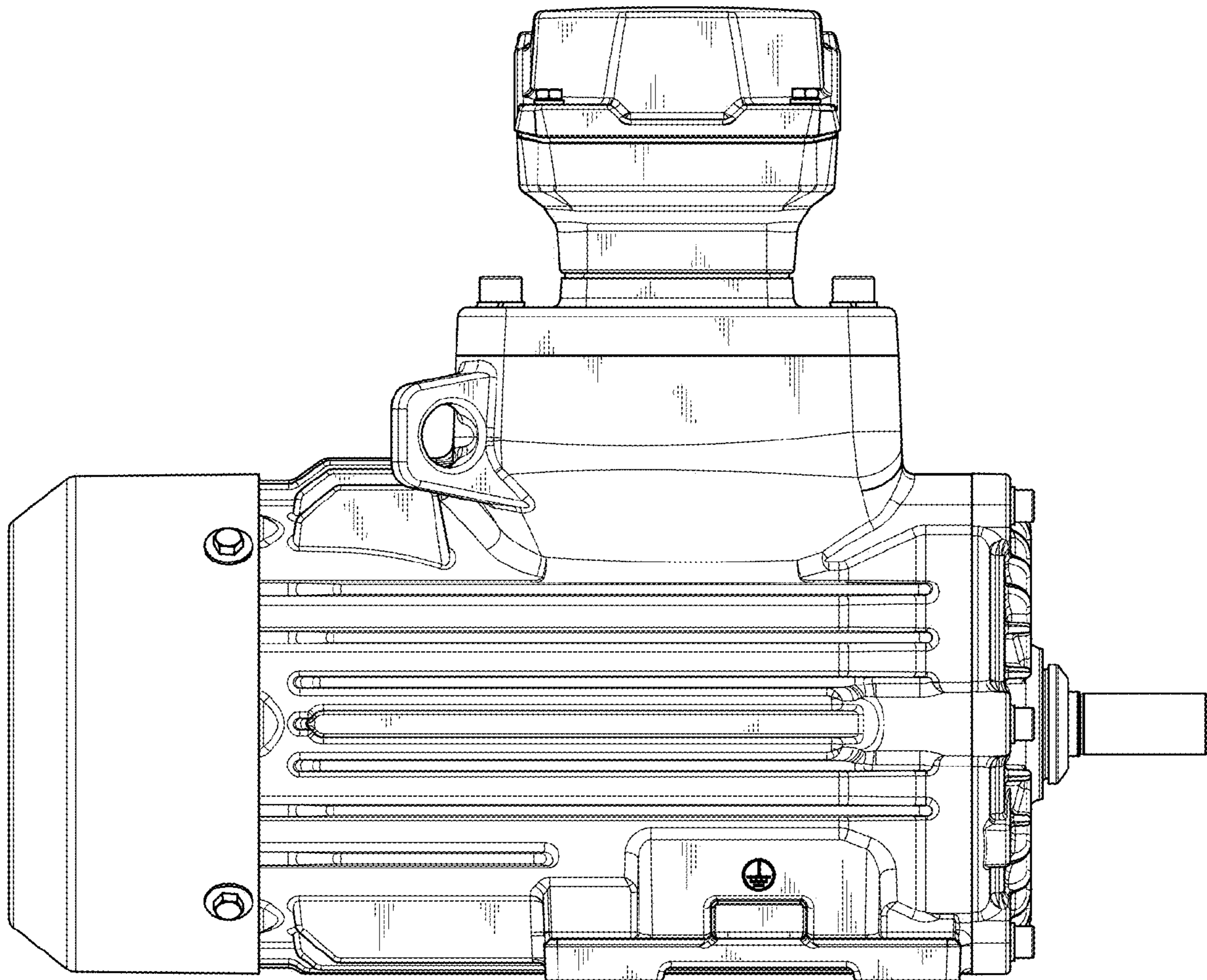



FIG. 7

