



US00D918075S

(12) **United States Design Patent** (10) **Patent No.:** **US D918,075 S**
Shu (45) **Date of Patent:** **** May 4, 2021**

(54) **CAR DATA SCANNER**

(71) Applicant: **Shanshan Shu**, Shenzhen (CN)

(72) Inventor: **Shanshan Shu**, Shenzhen (CN)

(**) Term: **15 Years**

(21) Appl. No.: **29/758,066**

(22) Filed: **Nov. 12, 2020**

(51) **LOC (13) Cl.** **10-04**

(52) **U.S. Cl.**
USPC **D10/78**

(58) **Field of Classification Search**
USPC D10/75, 78

CPC G01D 5/00; G06F 1/166; G06F 1/1656;
G06F 1/1626; G06F 1/1609; G06F 1/637;
G06F 3/03547; G06F 3/04842; G06F
3/04817; G06F 21/00; G06F 17/00;
G01M 17/00; G01M 17/007; G01M
15/05; F17D 1/08; F02P 17/08; G01R
31/3648; G01R 31/3693; G01R 31/3627;
G01R 31/31907; G01R 31/319; G01R
31/28; G01R 31/007; G07C 2205/02;
G07C 5/00; G07C 5/002; G07C 5/004;
G07C 5/006; G07C 5/008; G07C 5/02;
G07C 5/04; G07C 5/06; G07C 5/08;
G07C 5/0808; G07C 5/0816; G07C
5/0825; G07C 5/0833; G07C 5/0841;
G07C 5/085; G07C 5/0858; G07C
5/0866; G07C 5/0875; G07C 5/0883;
G07C 5/0891; G07C 3/00; G08B 21/187;
G08B 21/182; G05B 15/02; F16M 13/02;
F16B 2001/0035

See application file for complete search history.

(56) **References Cited**

U.S. PATENT DOCUMENTS

D374,183 S * 10/1996 Skinner D10/78
D519,046 S * 4/2006 Lipscomb D10/78
7,085,680 B2 * 8/2006 Huang G06F 11/0739
702/119
8,032,419 B2 * 10/2011 Chenn G06Q 30/0609
705/26.1

OTHER PUBLICATIONS

“Bafx Products Wireless Bluetooth Obd2 Scanner Diagnostic Code Reader & Scan Tool for Android Devices Only—Scan, Reset & Clear Car Check Engine Light”, Retrieved Nov. 11, 2020]. Retrieved from Internet, <https://www.amazon.com/BAFX-Products-Wireless-Bluetooth-Diagnostic/dp/B005NLQAHS/ref>.

* cited by examiner

Primary Examiner — Antoine Duval Davis

(57) **CLAIM**

The ornamental design for a car data scanner, as shown and described.

DESCRIPTION

FIG. 1 is a perspective view of a car data scanner showing my new design;
FIG. 2 is another perspective view thereof;
FIG. 3 is a front elevational view thereof;
FIG. 4 is a rear elevational view thereof;
FIG. 5 is a left side elevational view thereof;
FIG. 6 is a right side elevational view thereof;
FIG. 7 is a top plan view thereof; and,
FIG. 8 is a bottom plan view thereof.
The broken lines in the drawings depict portions of the car data scanner that form no part of the claimed design.

1 Claim, 8 Drawing Sheets

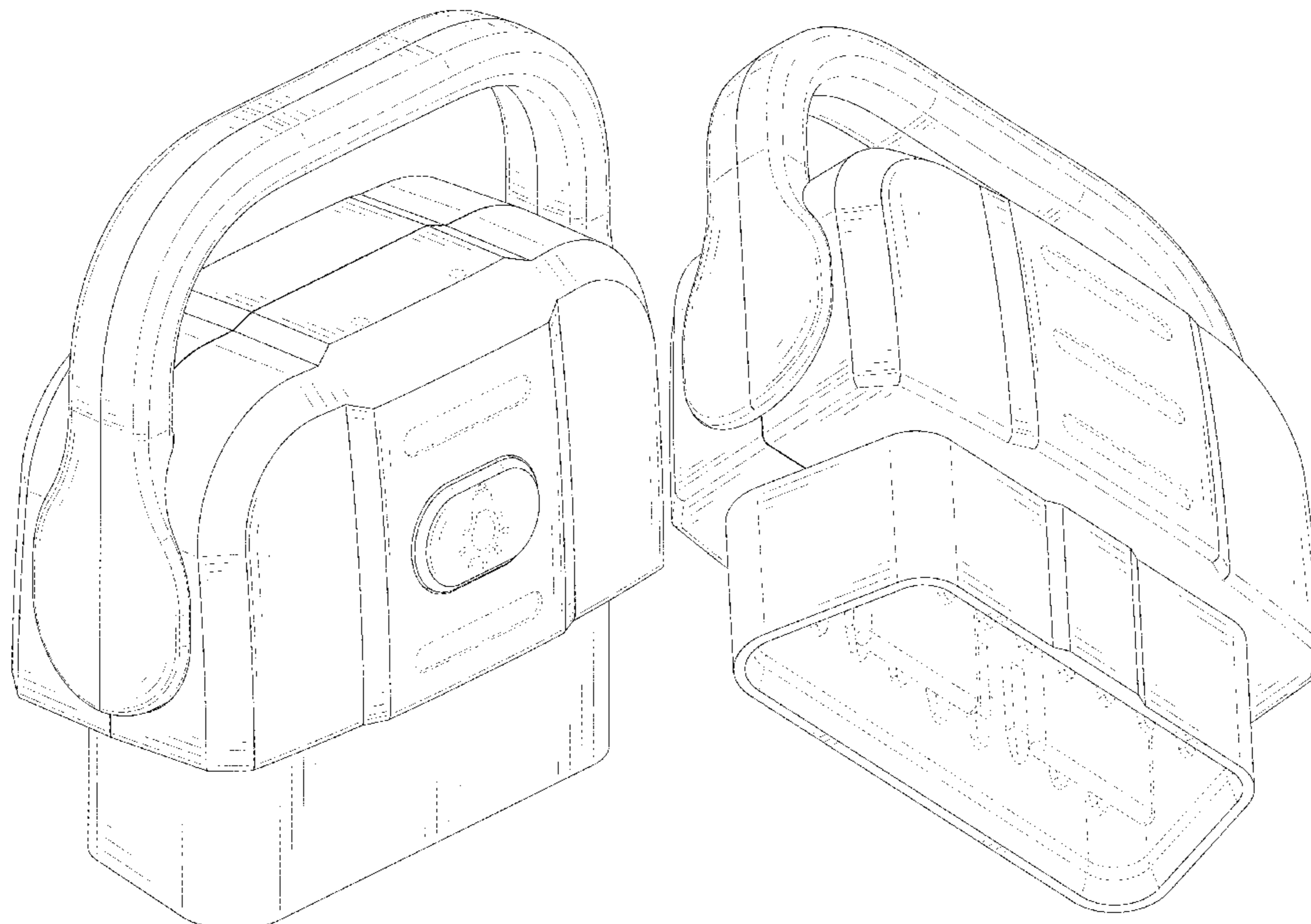

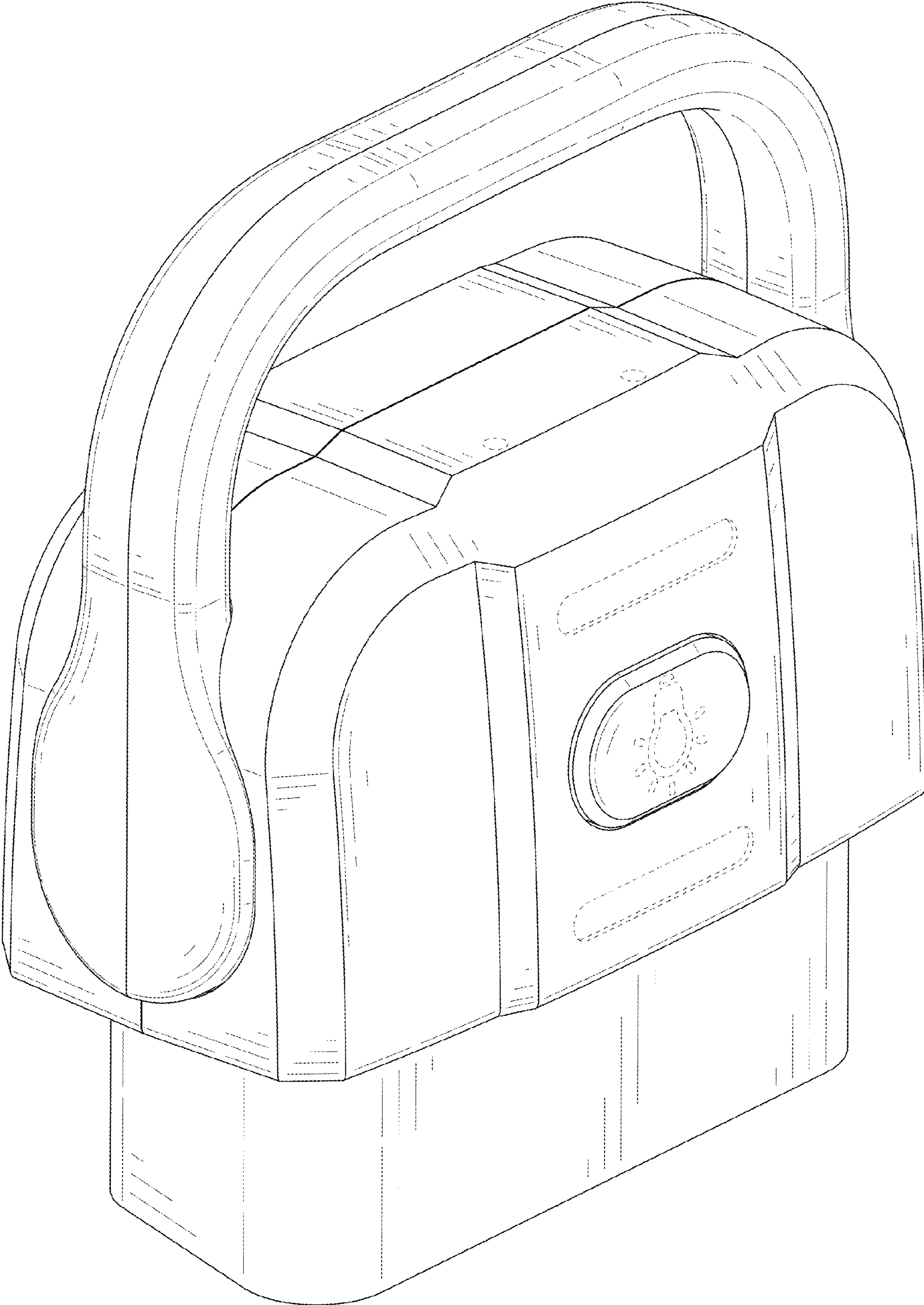

FIG. 1

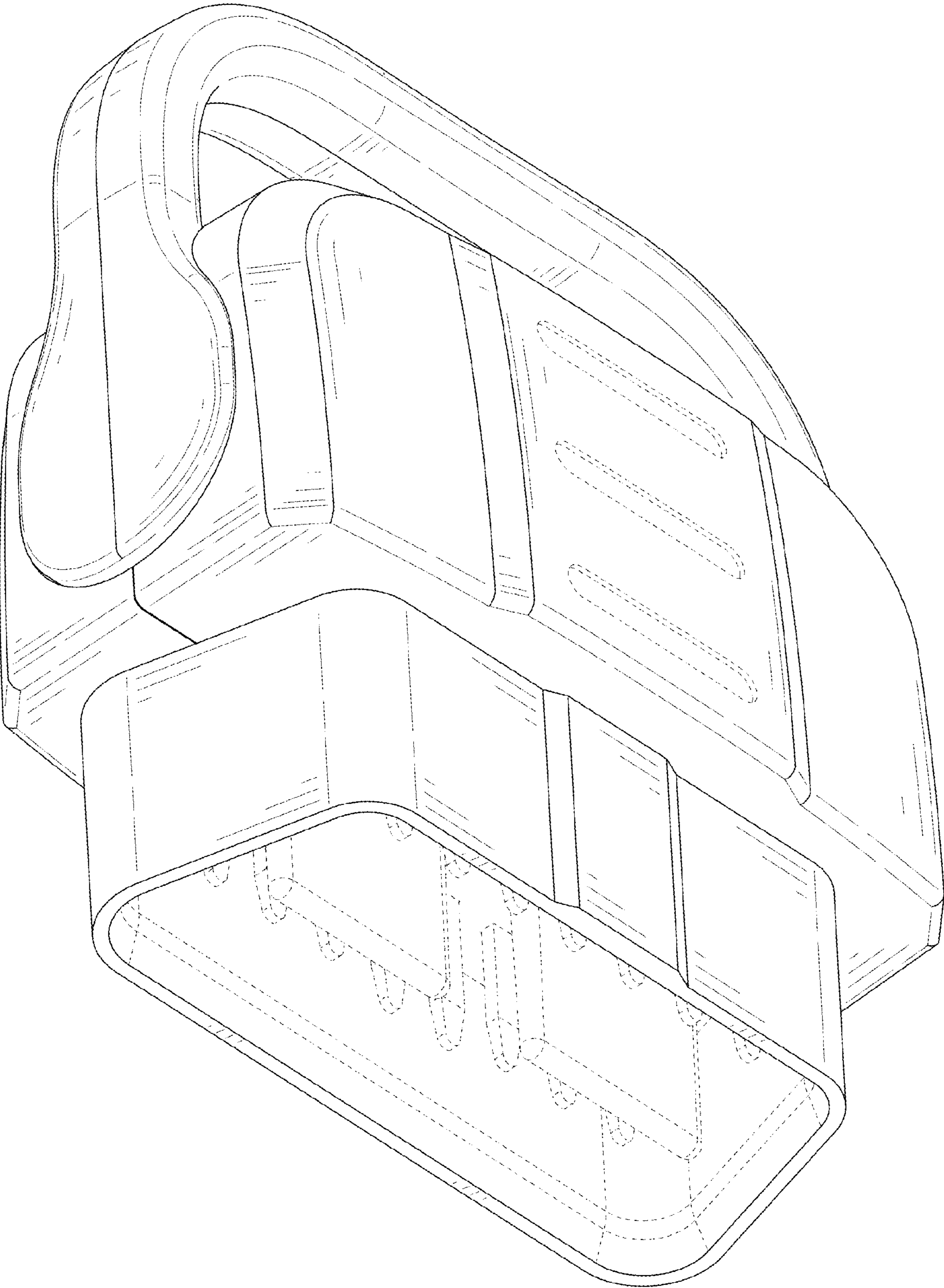

FIG. 2

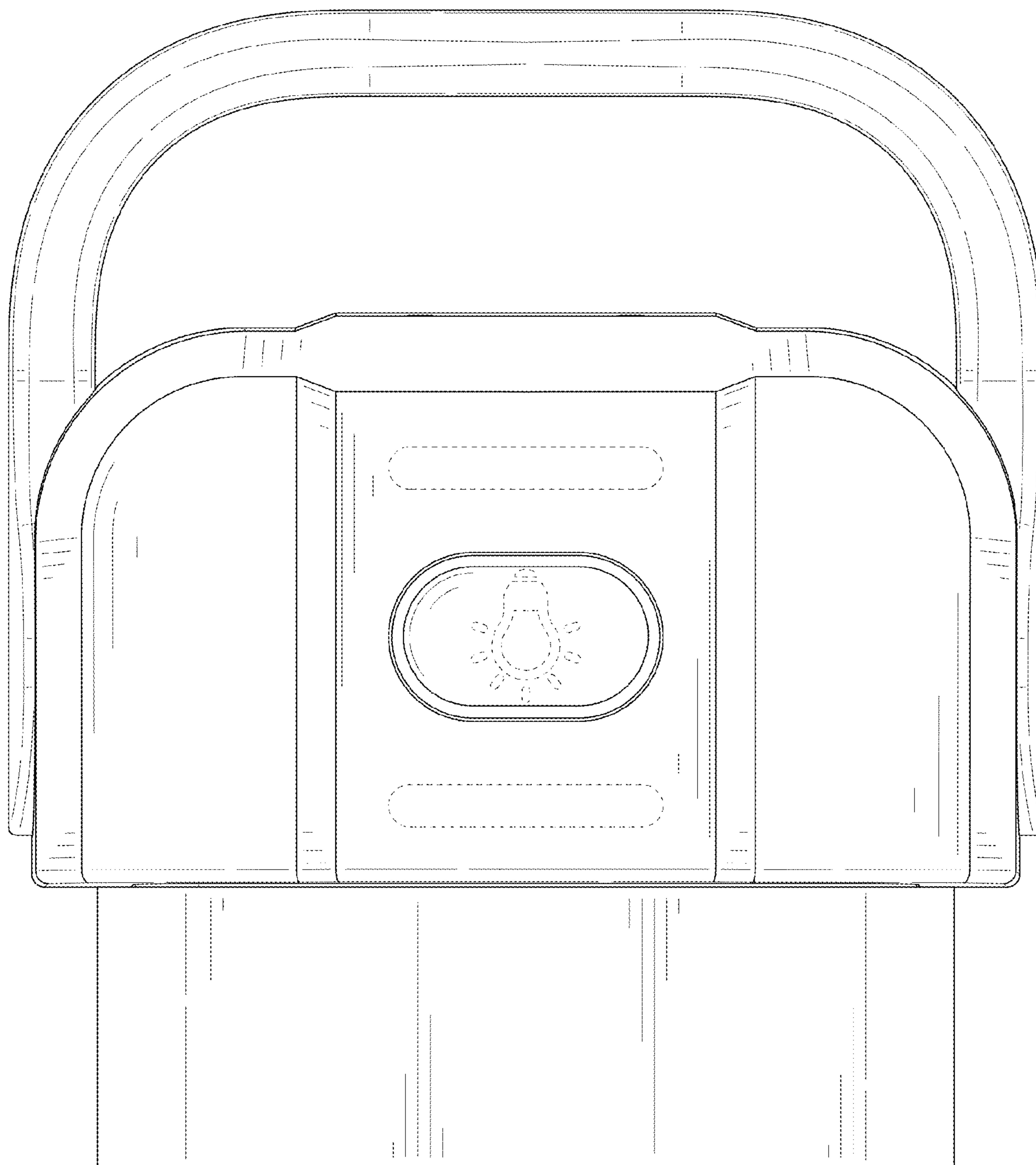

FIG. 3

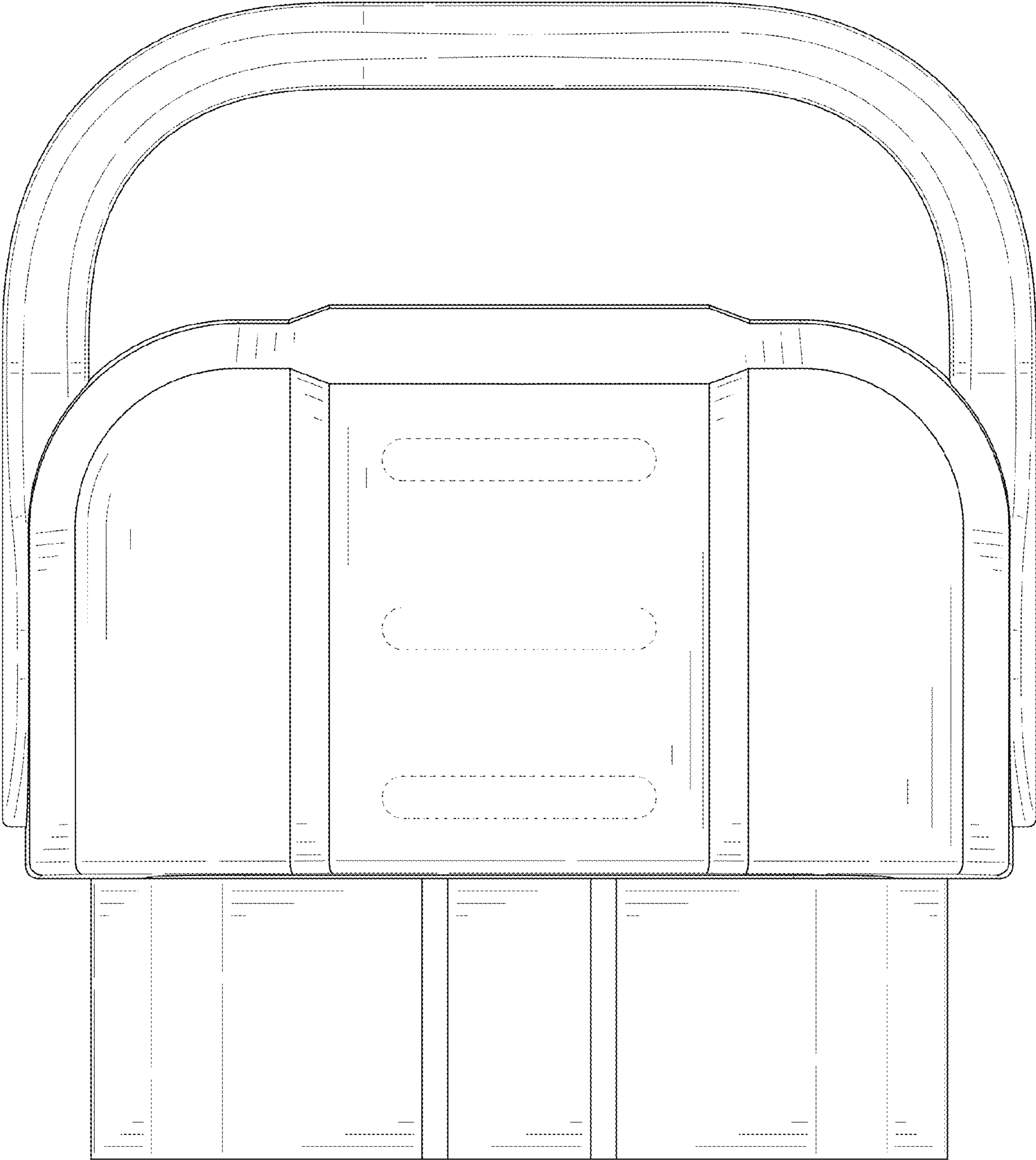

FIG. 4

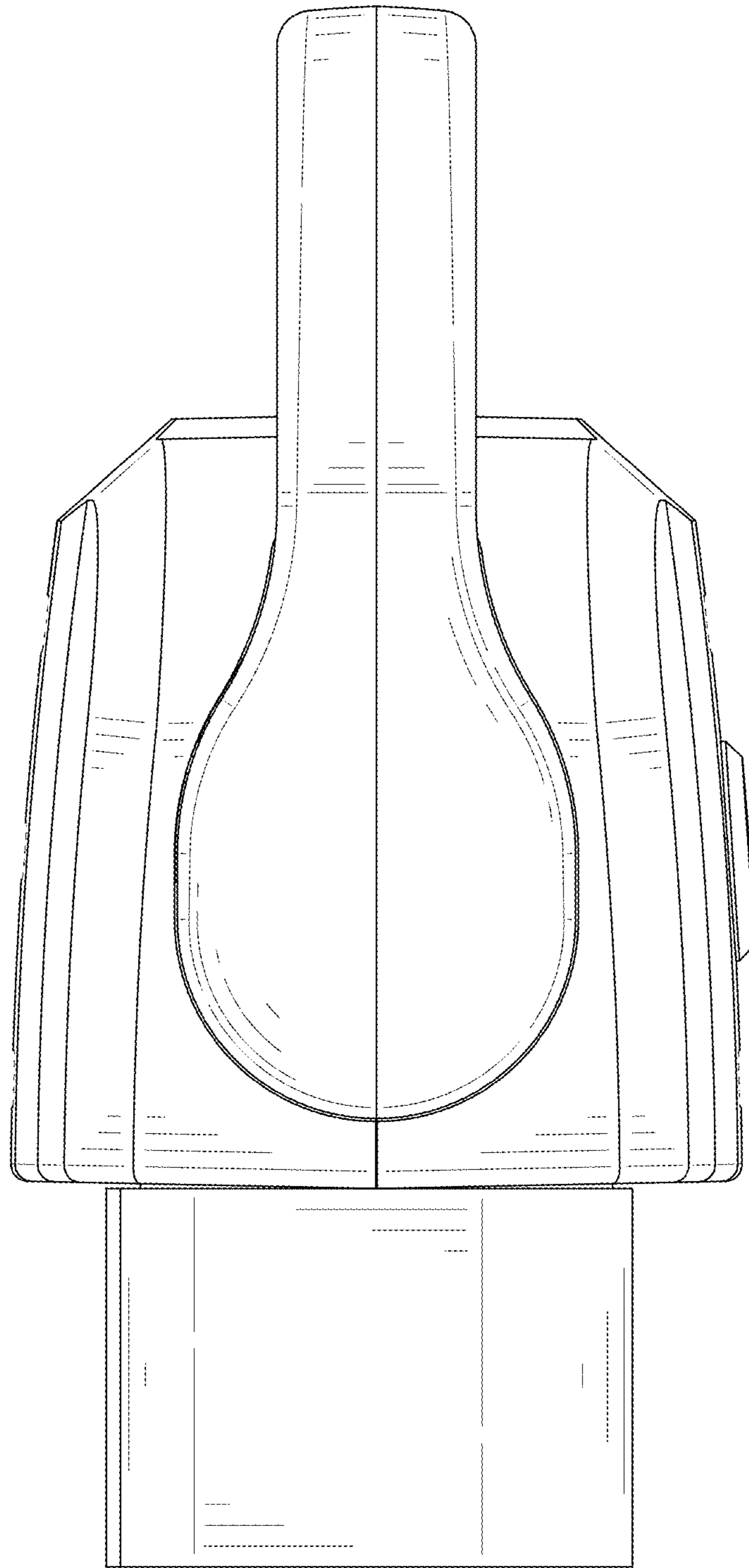

FIG. 5

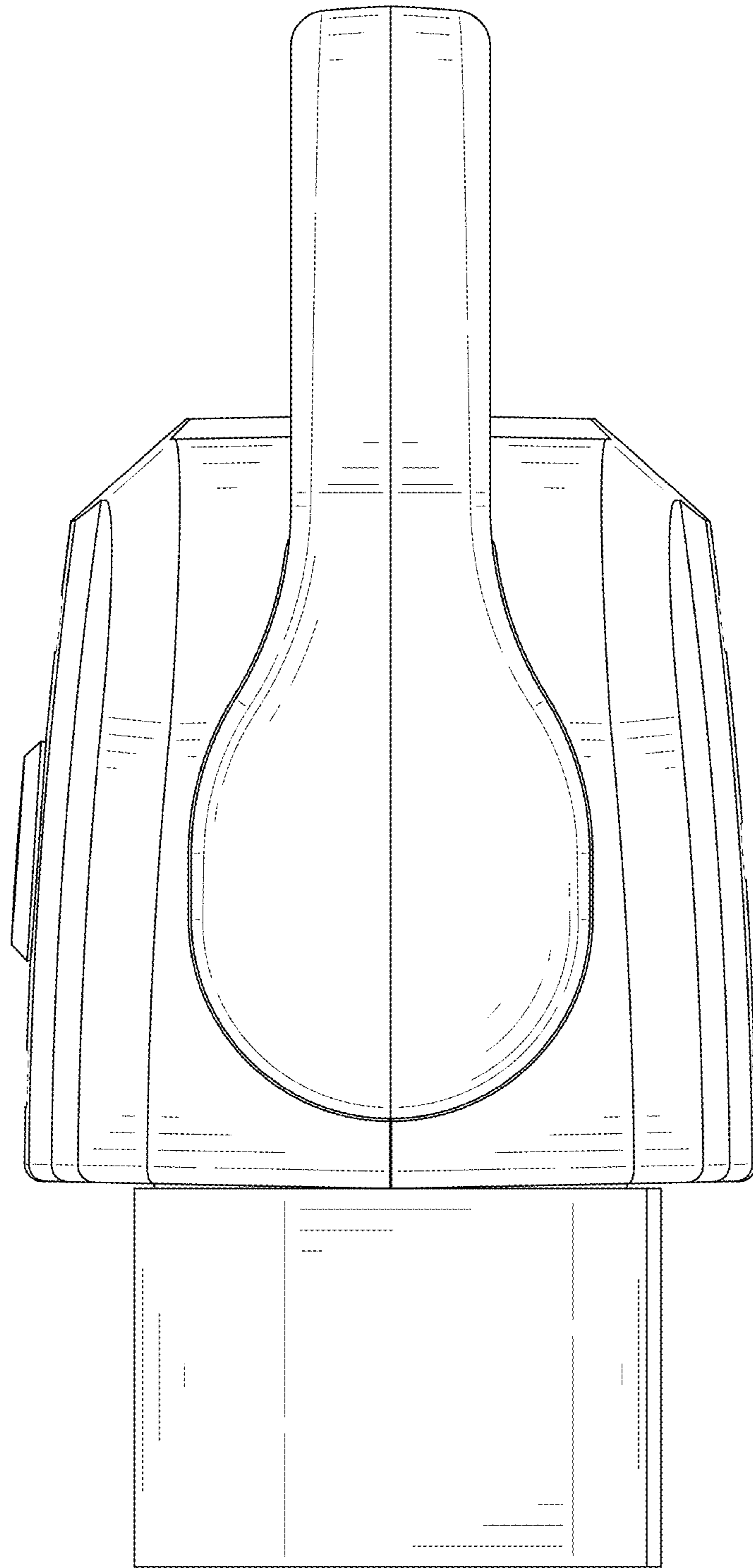

FIG. 6

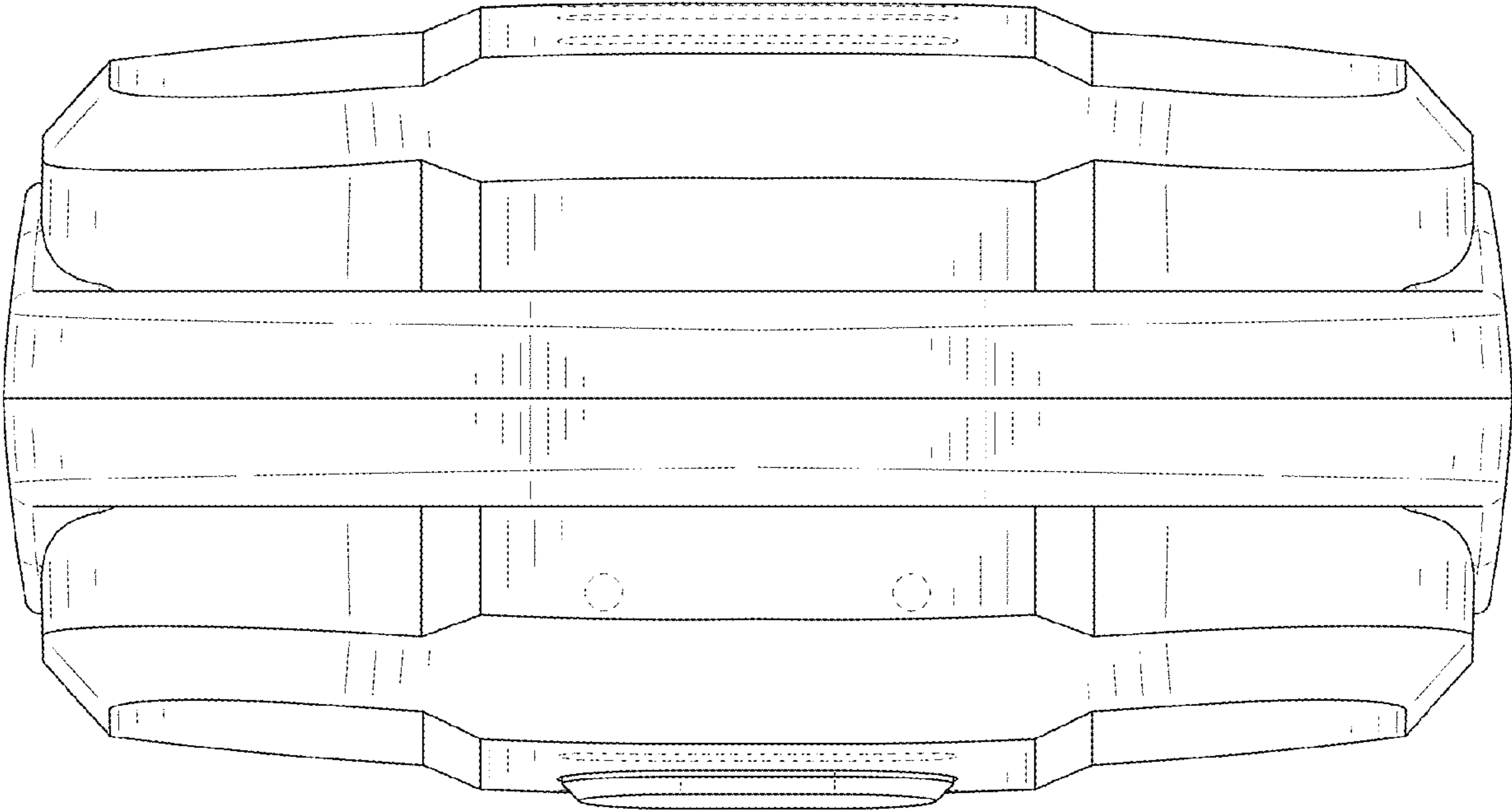

FIG. 7

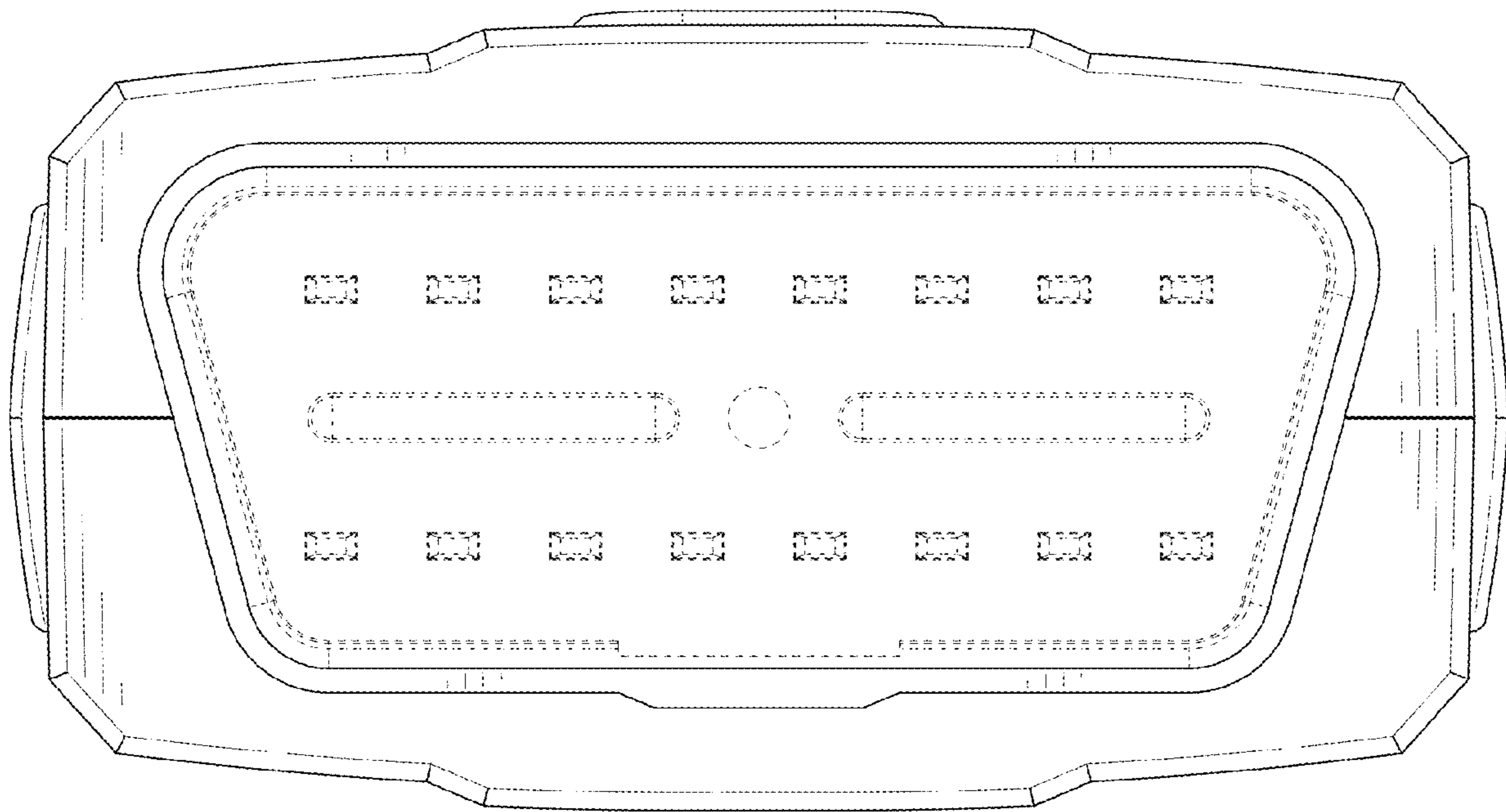

FIG. 8