



US00D918054S

(12) **United States Design Patent**  
**Papiernik**

(10) **Patent No.:** **US D918,054 S**

(45) **Date of Patent:** **\*\* May 4, 2021**

(54) **PERFUME BOTTLE**

(71) Applicant: **LVMH FRAGRANCE BRANDS,**  
Levallois Perret (FR)

(72) Inventor: **Elie Papiernik,** Paris (FR)

(73) Assignee: **LVMH FRAGRANCE BRANDS,**  
Levallois Perret (FR)

(\*\*) Term: **15 Years**

(21) Appl. No.: **29/696,089**

(22) Filed: **Jun. 25, 2019**

(30) **Foreign Application Priority Data**

Dec. 26, 2018 (EM) ..... 005943982

(51) **LOC (13) Cl.** ..... **09-01**

(52) **U.S. Cl.**  
USPC ..... **D9/566**

(58) **Field of Classification Search**  
USPC ..... D9/454, 516, 522, 544, 546, 559, 560,  
D9/563, 567, 566, 651, 715, 719;  
D7/598, 601, 602; D3/202; D28/81,  
D28/91.1

CPC ..... B65D 11/04; B65D 1/0223; B65D 11/10;  
B65D 1/18; B65D 2501/0081; A47K  
5/12; A45D 34/00

See application file for complete search history.

(56) **References Cited**

**U.S. PATENT DOCUMENTS**

D71,782 S \* 1/1927 Delaize ..... D9/544  
D79,935 S \* 11/1929 Peszynska ..... D9/529  
D86,566 S \* 3/1932 Gibson ..... D9/544  
D120,147 S \* 4/1940 Steuer ..... D9/568  
D126,514 S \* 4/1941 Payne ..... D9/566  
D168,312 S \* 12/1952 Linnard ..... D9/568  
D187,886 S \* 5/1960 Hurlestone ..... D9/566  
D207,802 S \* 5/1967 Du Pree ..... D7/300

D235,510 S \* 6/1975 Blat ..... D9/546  
D247,282 S \* 2/1978 Zimmermann ..... D9/521  
D256,433 S \* 8/1980 Kretz ..... D7/300  
D257,225 S \* 10/1980 Kretz ..... D7/300  
D333,269 S \* 2/1993 Albright ..... D9/439  
D379,766 S \* 6/1997 Schneider ..... D9/542  
D433,938 S \* 11/2000 Polan ..... D9/560  
D471,467 S \* 3/2003 Kokubo ..... D9/566  
D526,567 S \* 8/2006 Dalton ..... D9/544

(Continued)

**FOREIGN PATENT DOCUMENTS**

RU 00122118 \* 10/2020

**OTHER PUBLICATIONS**

Barbour for Him, available Jan. 30, 2016, [online], [site visited Mar. 11, 2021]. Available from internet, URL: [https://www.parfumo.net/Perfumes/Barbour/Barbour\\_for\\_Him](https://www.parfumo.net/Perfumes/Barbour/Barbour_for_Him) (Year: 2016).\*

*Primary Examiner* — W. A. Teddy Falloway  
(74) *Attorney, Agent, or Firm* — McNeas Wallace & Nurick LLC

(57) **CLAIM**

The ornamental design for a perfume bottle, as shown and described.

**DESCRIPTION**

FIG. 1 is a top-front-right perspective view of a perfume bottle, showing the design;  
FIG. 2 is a front view of the perfume bottle of FIG. 1;  
FIG. 3 is a rear view of the perfume bottle of FIG. 1;  
FIG. 4 is a right view of the perfume bottle of FIG. 1;  
FIG. 5 is a left view of the perfume bottle of FIG. 1;  
FIG. 6 is a top view of the perfume bottle of FIG. 1; and,  
FIG. 7 is a bottom view of the perfume bottle of FIG. 1.  
The broken lines in the drawings showing the perfume bottle illustrate the portions of the perfume bottle that form no part of the claimed design.

**1 Claim, 6 Drawing Sheets**

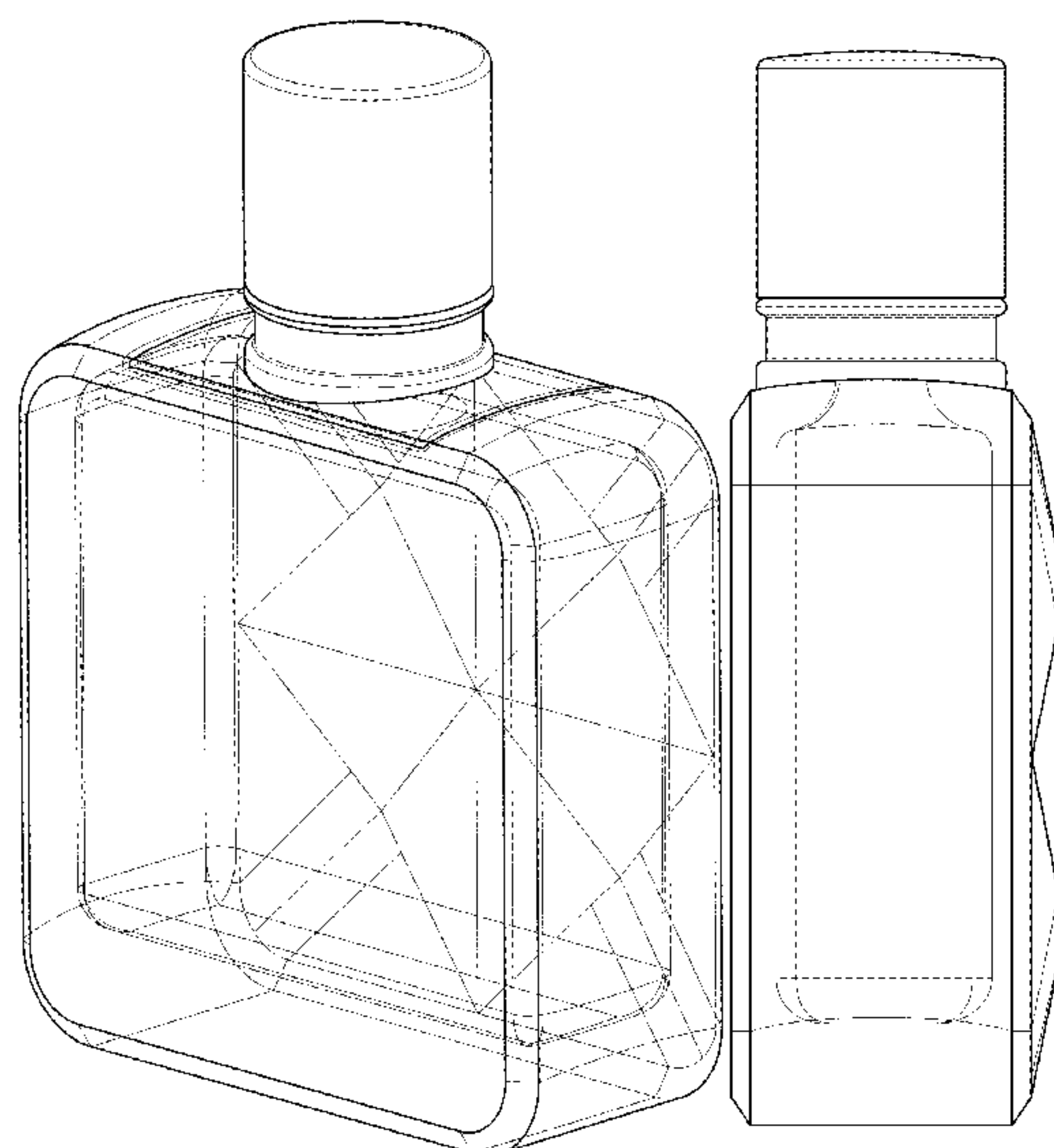

(56)

**References Cited**

## U.S. PATENT DOCUMENTS

D592,072	S	*	5/2009	Mansau	.....	D9/694
D610,013	S	*	2/2010	Mendelson	.....	D9/522
D625,612	S	*	10/2010	Papiernik	.....	D9/693
D626,422	S	*	11/2010	Lloyd	.....	D9/566
D632,969	S	*	2/2011	Monteparo	.....	D9/544
D660,178	S	*	5/2012	Chen	.....	D9/694
D675,529	S	*	2/2013	Jacobs	.....	D9/522
D696,957	S	*	1/2014	Pinabel	.....	D9/555
D710,207	S	*	8/2014	Pinabel	.....	D9/542
D714,654	S	*	10/2014	Failant Dumas	.....	D9/682
D741,721	S	*	10/2015	Monteparo	.....	D9/566
D784,150	S	*	4/2017	Dumas	.....	D9/563
D786,689	S	*	5/2017	Dalton	.....	D9/573
D790,352	S	*	6/2017	Staab	.....	D9/574
D802,428	S	*	11/2017	Staab	.....	D9/522
D803,691	S	*	11/2017	Staab	.....	D9/522
D810,580	S	*	2/2018	Staab	.....	D9/682
D813,041	S	*	3/2018	Staab	.....	D9/522
D833,290	S	*	11/2018	Byron	.....	D9/559
D852,055	S	*	6/2019	Goulet Dubois	.....	D9/651
D852,638	S	*	7/2019	Ericson	.....	D9/686
D854,937	S	*	7/2019	Li	.....	D9/573
D856,810	S	*	8/2019	James	.....	D9/566
D856,811	S	*	8/2019	James	.....	D9/566
D896,658	S	*	9/2020	James	.....	D9/566
D903,861	S	*	12/2020	Otsu	.....	D24/119

\* cited by examiner

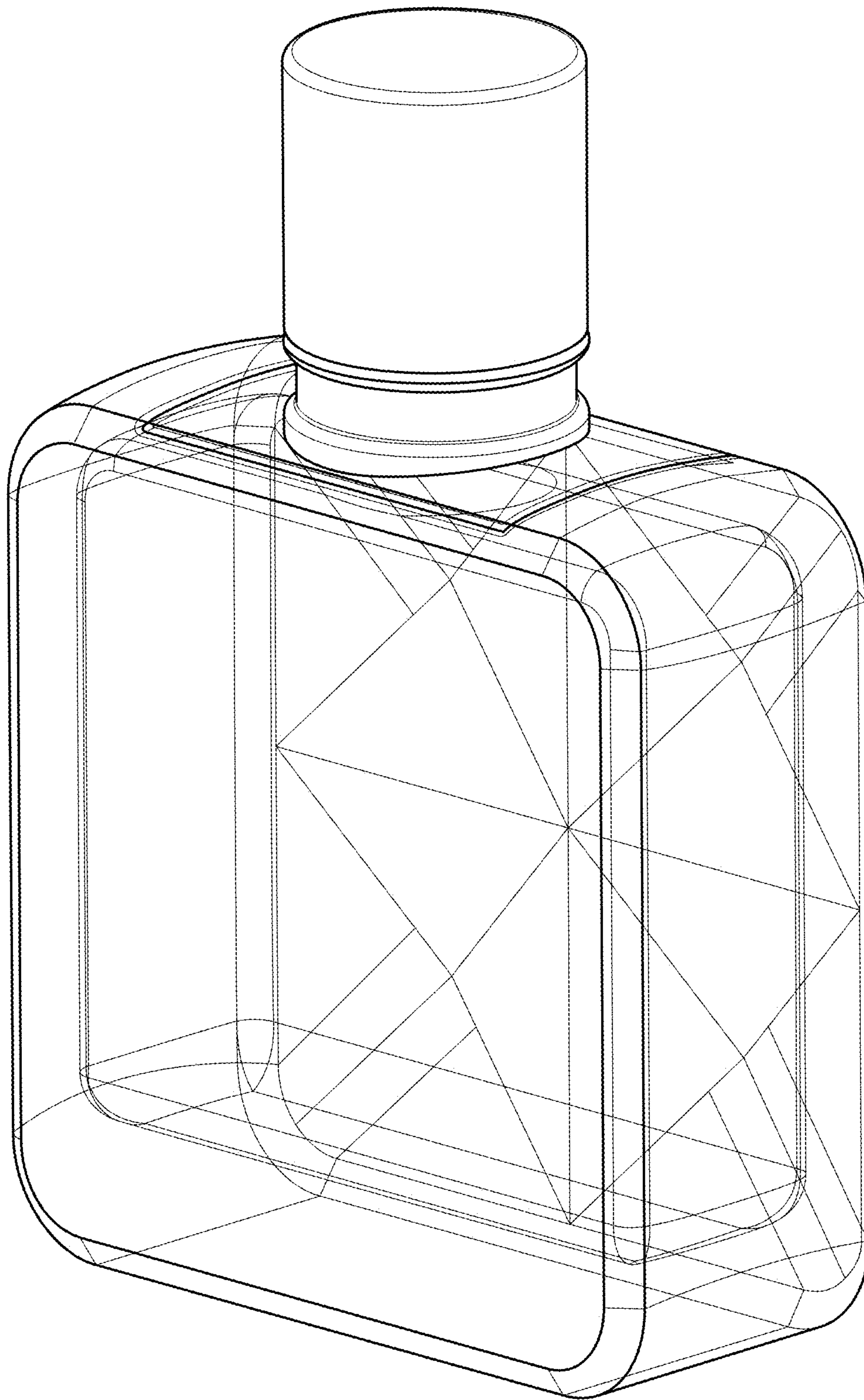

FIG. 1





FIG. 2

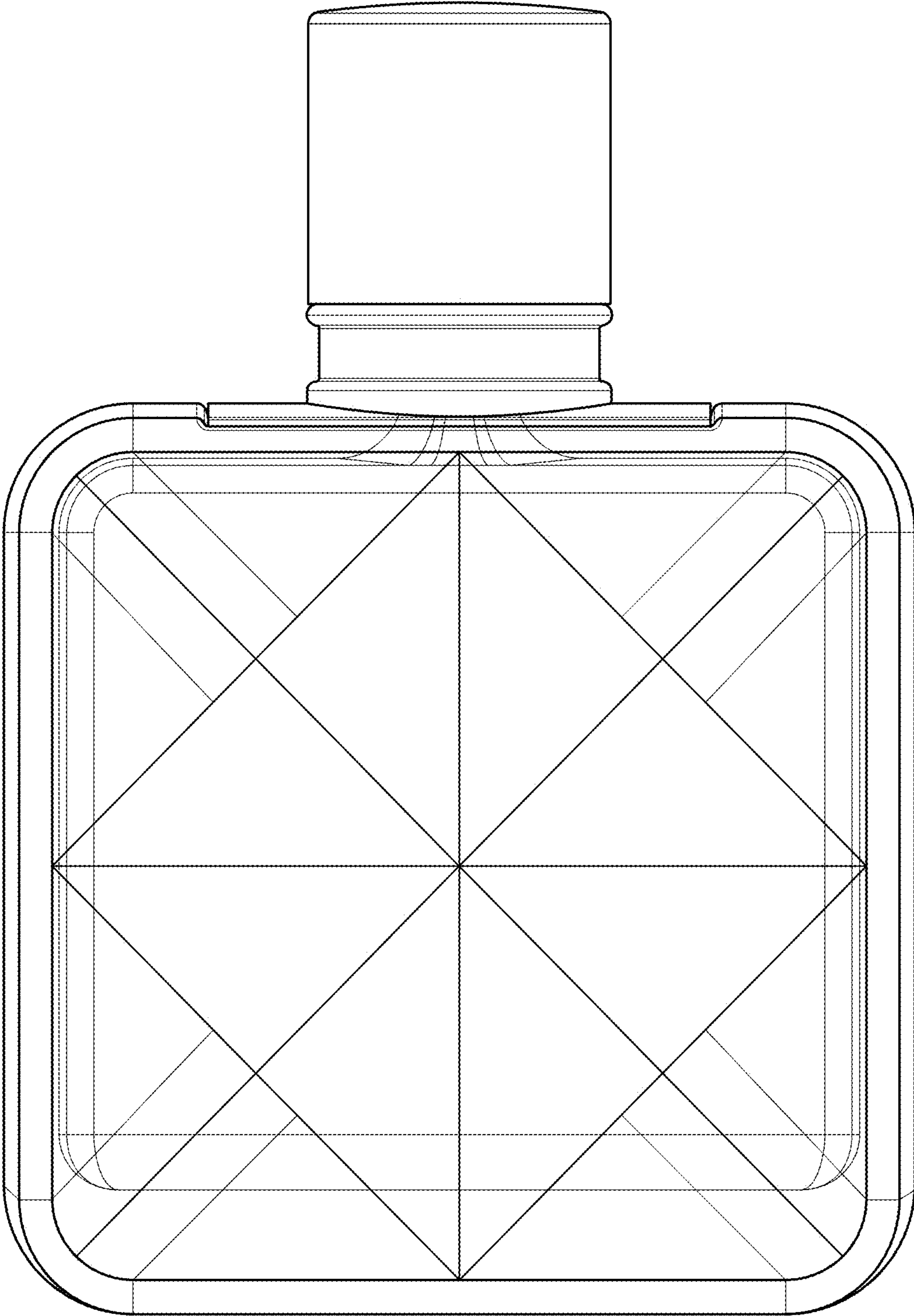

FIG. 3

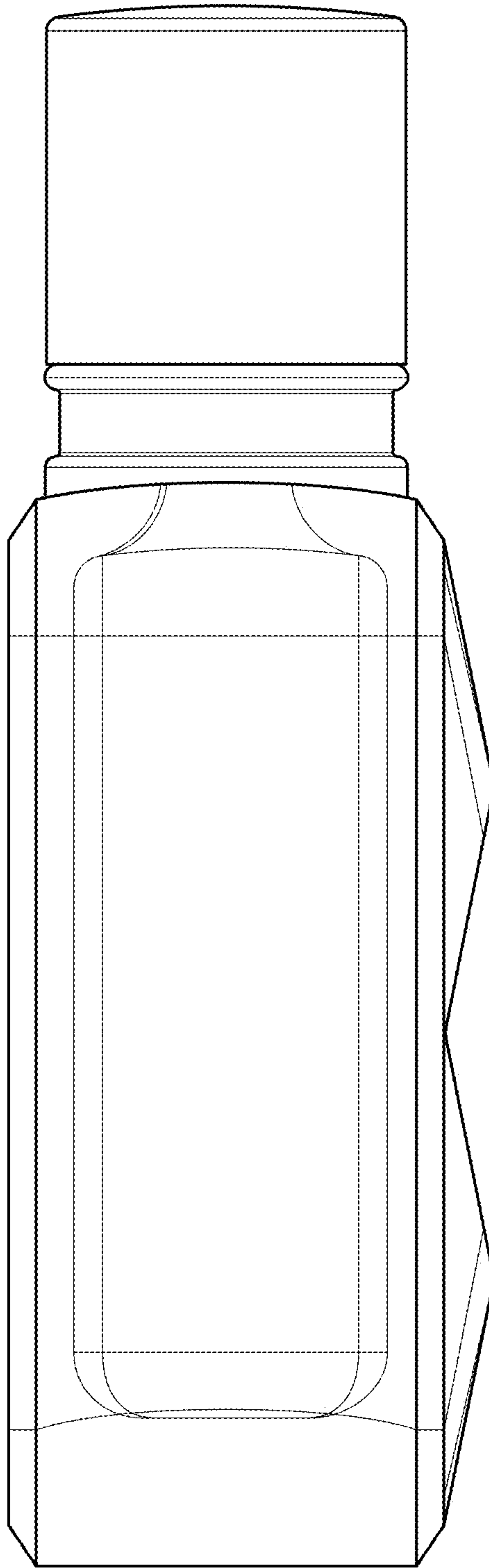

FIG. 4

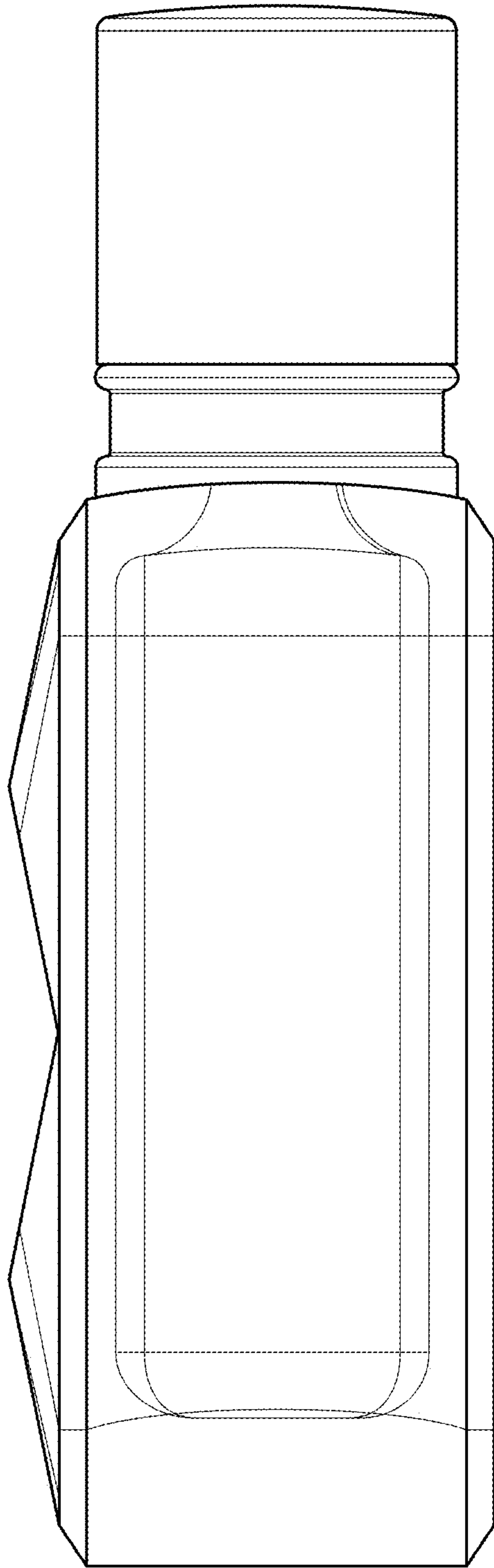

FIG. 5

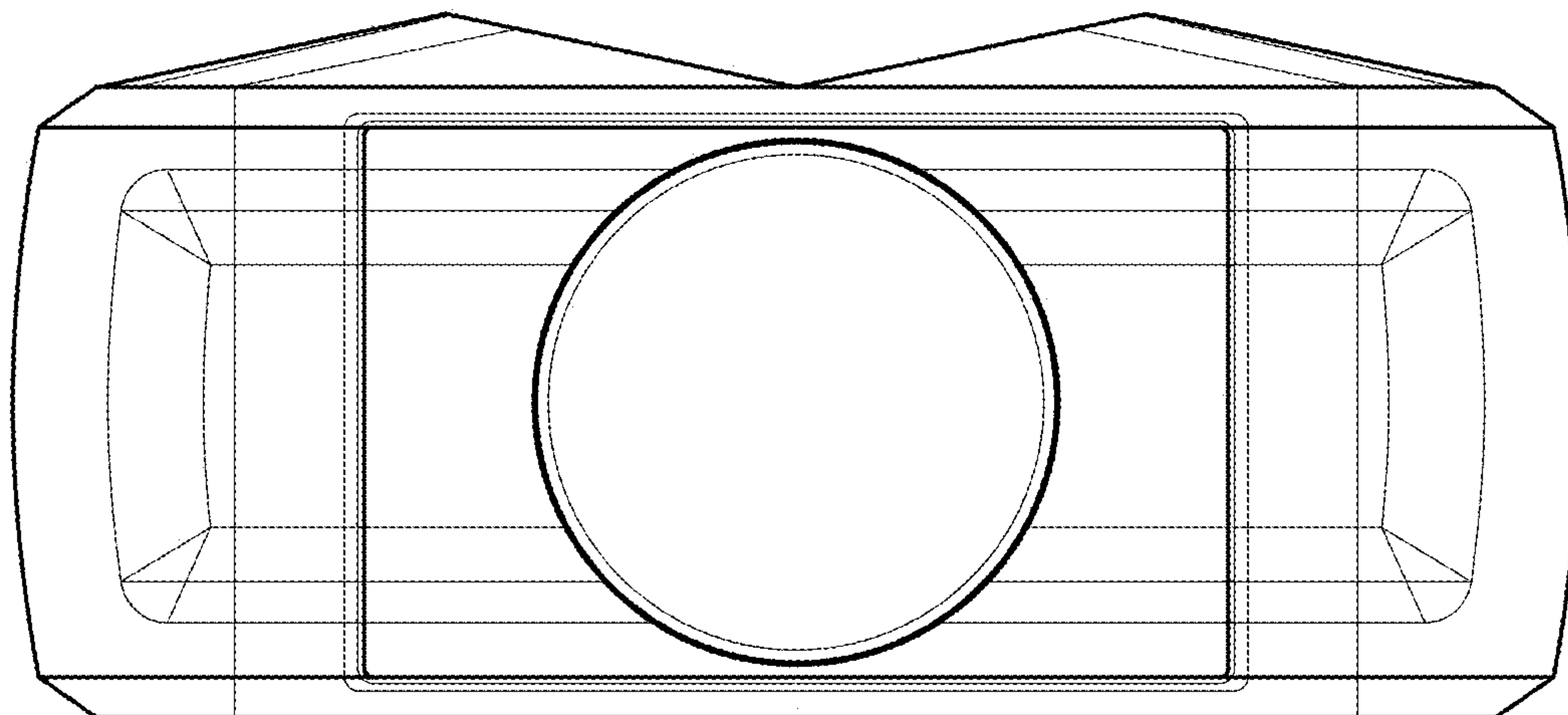

FIG. 6

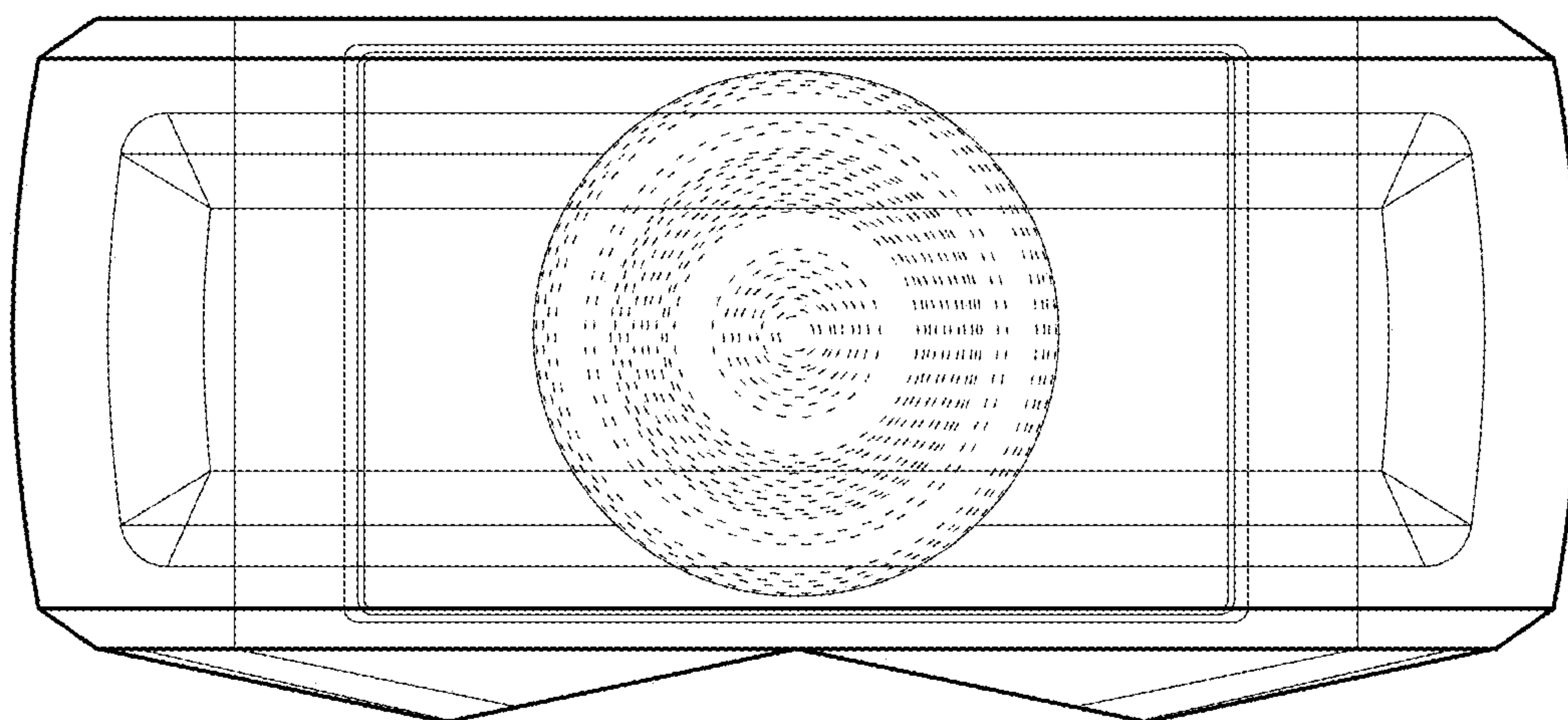

FIG. 7