



US00D917984S

(12) **United States Design Patent** (10) **Patent No.:** **US D917,984 S**
Wang (45) **Date of Patent:** **** May 4, 2021**

(54) **KNIFE BLADE**

(71) Applicants: **Hangzhou United Tools Co., Ltd.**,
Hangzhou (CN); **Hangzhou Great Star
Industrial Co., Ltd.**, Hangzhou (CN)

(72) Inventor: **Weiyi Wang**, Hangzhou (CN)

(73) Assignees: **Hangzhou United Tools Co., Ltd.**,
Hangzhou (CN); **Hangzhou Great Star
Industrial Co., Ltd.**, Hangzhou (CN)

(**) Term: **15 Years**

(21) Appl. No.: **29/670,533**

(22) Filed: **Nov. 16, 2018**

(30) **Foreign Application Priority Data**

Aug. 7, 2018 (CN) 201830432539.3

(51) **LOC (13) Cl.** **07-03**

(52) **U.S. Cl.**
USPC **D7/649**; D7/401.2; D7/650

(58) **Field of Classification Search**
USPC D7/393-395, 401.2, 642-652, 693,
D7/695-696; D8/93, 97-100, 107, 300,
D8/321; D22/117-118
CPC A01B 1/20; A01B 1/22; A22C 25/006;
A47G 21/06; A47G 21/065; A47J 43/25;
A61B 17/3211; A61B 17/3213; B21D
53/64; B25G 1/102; B25G 3/36; B26B
1/00; B26B 1/08; B26B 1/10; B26B 3/00;
B26B 3/02; B26B 3/03; B26B 3/04;
B26B 3/06; B26B 5/00; B26B 5/001;
B26B 5/007; B26B 7/00; B26B 7/005;
B26B 9/00; B26B 9/02; B26B 11/00;
B26B 11/006; B26B 17/00; B26B 17/006;
B26B 29/02

See application file for complete search history.

(56) **References Cited**

U.S. PATENT DOCUMENTS

D358,968 S * 6/1995 Hirai D7/649
D359,789 S * 6/1995 Seber D22/118
D368,832 S * 4/1996 Held D7/645

(Continued)

OTHER PUBLICATIONS

Handmade Damascus Cleaver Knife by PAL. Date First Available
on Amazon.com Oct. 3, 2017 [https://www.amazon.com/PAL-2000-
KNIVES-Handmade-Damascus/dp/B07Y7MP77N/ref\(Year: 2017\).*](https://www.amazon.com/PAL-2000-KNIVES-Handmade-Damascus/dp/B07Y7MP77N/ref(Year: 2017).*)

Primary Examiner — Ricky Pham

(74) *Attorney, Agent, or Firm* — Andrus Intellectual
Property Law, LLP

(57) **CLAIM**

The ornamental design of a knife blade, as shown and
described.

DESCRIPTION

FIG. 1 is a perspective view of the knife blade;
FIG. 2 is a front elevational view thereof;
FIG. 3 is a rear elevational view thereof;
FIG. 4 is a left elevational view thereof;
FIG. 5 is a right elevational view thereof;
FIG. 6 is a top plan view thereof;
FIG. 7 is a bottom plan view thereof;
FIG. 8 is a closer view of an area identified in FIG. 2
showing embossments thereof;
FIG. 9 is a closer view of an area identified in FIG. 8;
FIG. 10 is a perspective view of the knife blade, shown in
use with a knife grip; and,
FIG. 11 is front elevational view of the knife blade in use
with the knife grip.
The portions of the knife blade shown in broken lines form
no part of the claimed design. The broken line showing of a
knife grip in FIGS. 10 and 11 illustrates environment; the
broken lines form no part of the claimed design.

1 Claim, 8 Drawing Sheets

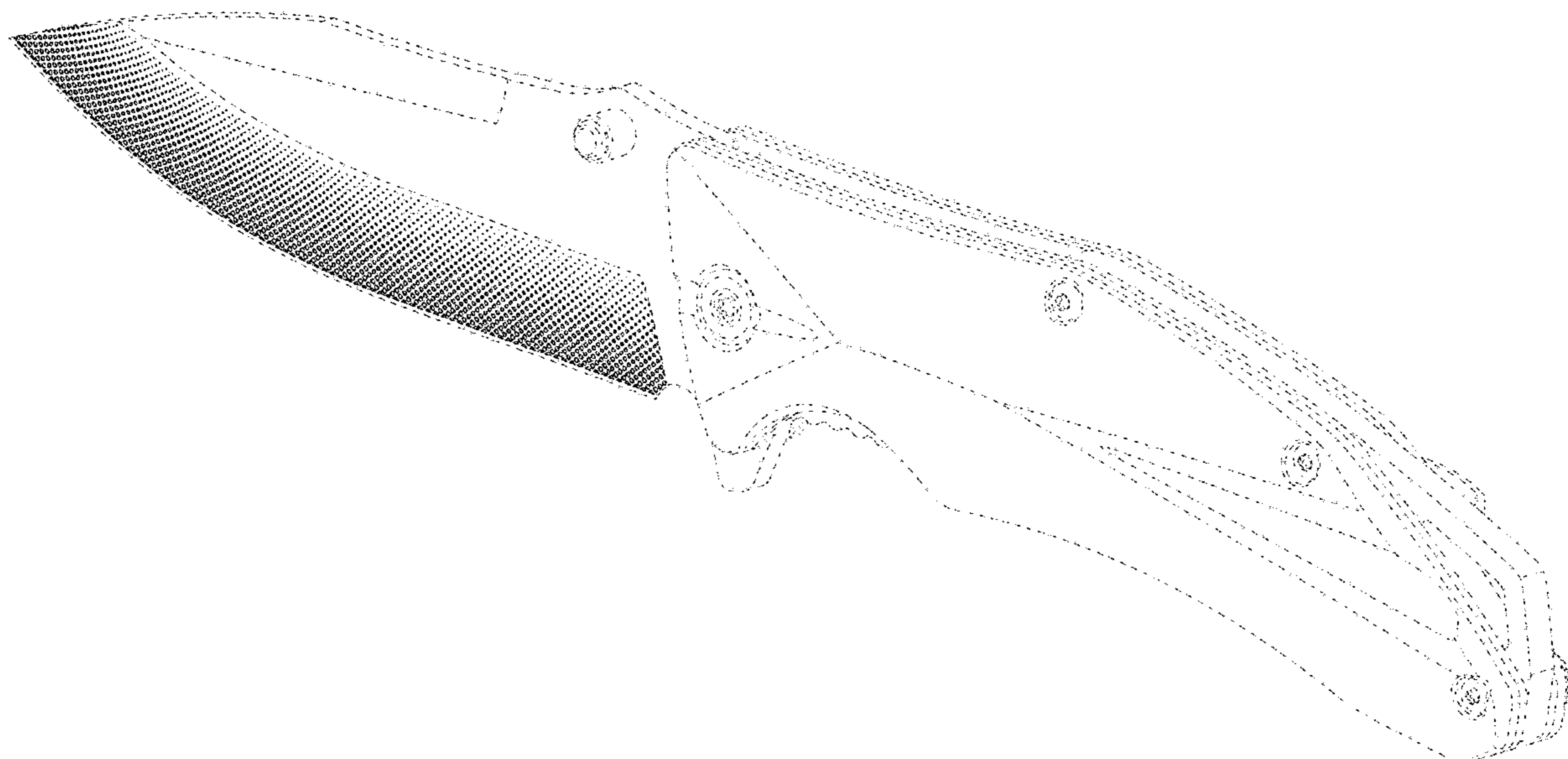

(56)

References Cited

U.S. PATENT DOCUMENTS

5,528,834 A * 6/1996 Seber B25G 1/102
30/340
D568,695 S * 5/2008 Seidenfaden D7/649
D631,292 S * 1/2011 Bodum D7/401.2
D696,083 S * 12/2013 Hollinger D7/650
D751,861 S * 3/2016 Yamada D7/401.2
D774,846 S * 12/2016 Pantschenko D7/650
D809,863 S * 2/2018 Yamada D7/401.2
D822,444 S * 7/2018 McGuyer D7/649
D850,571 S * 6/2019 Heine D22/118
10,369,710 B2 * 8/2019 Myvett A47J 43/25

* cited by examiner

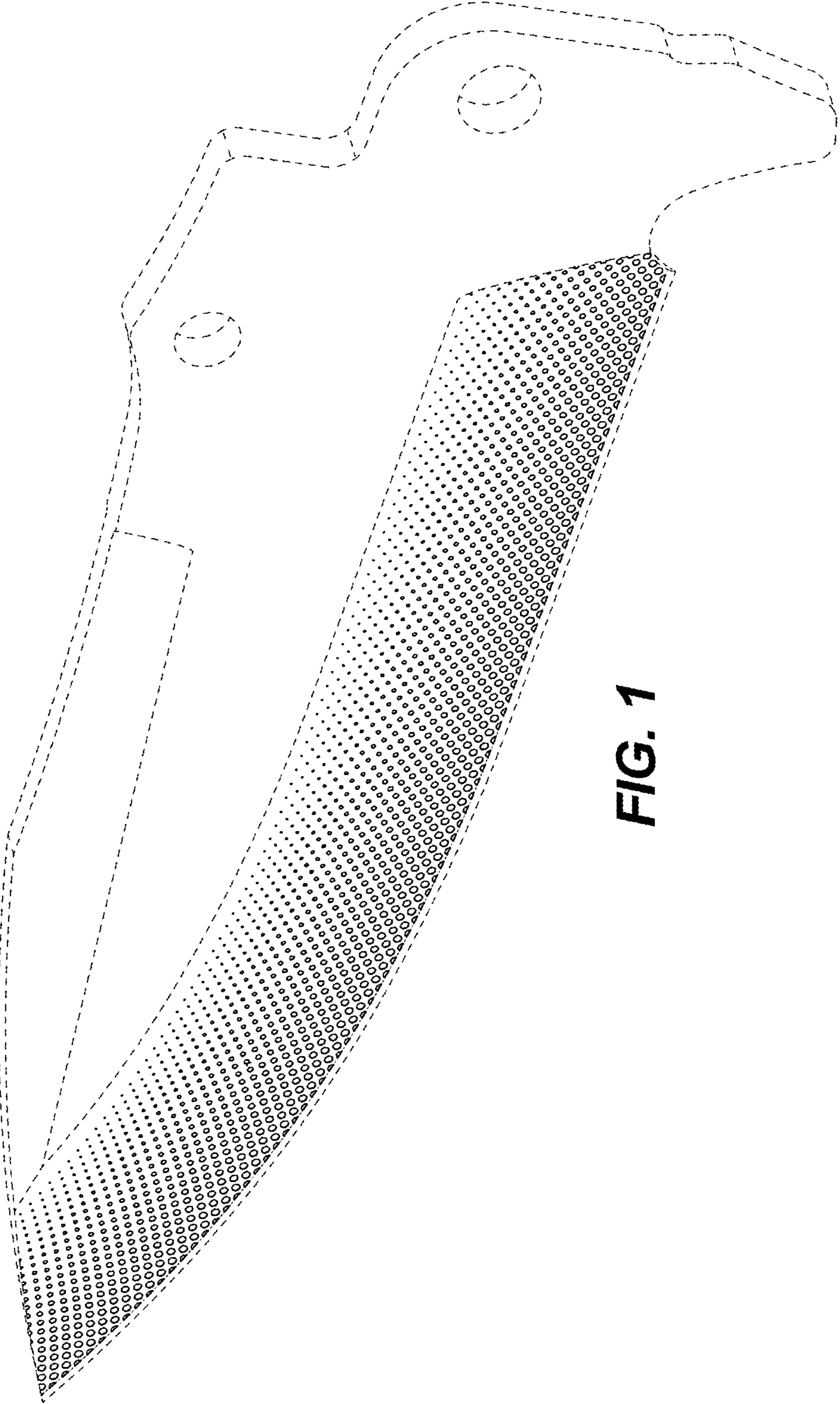

FIG. 1

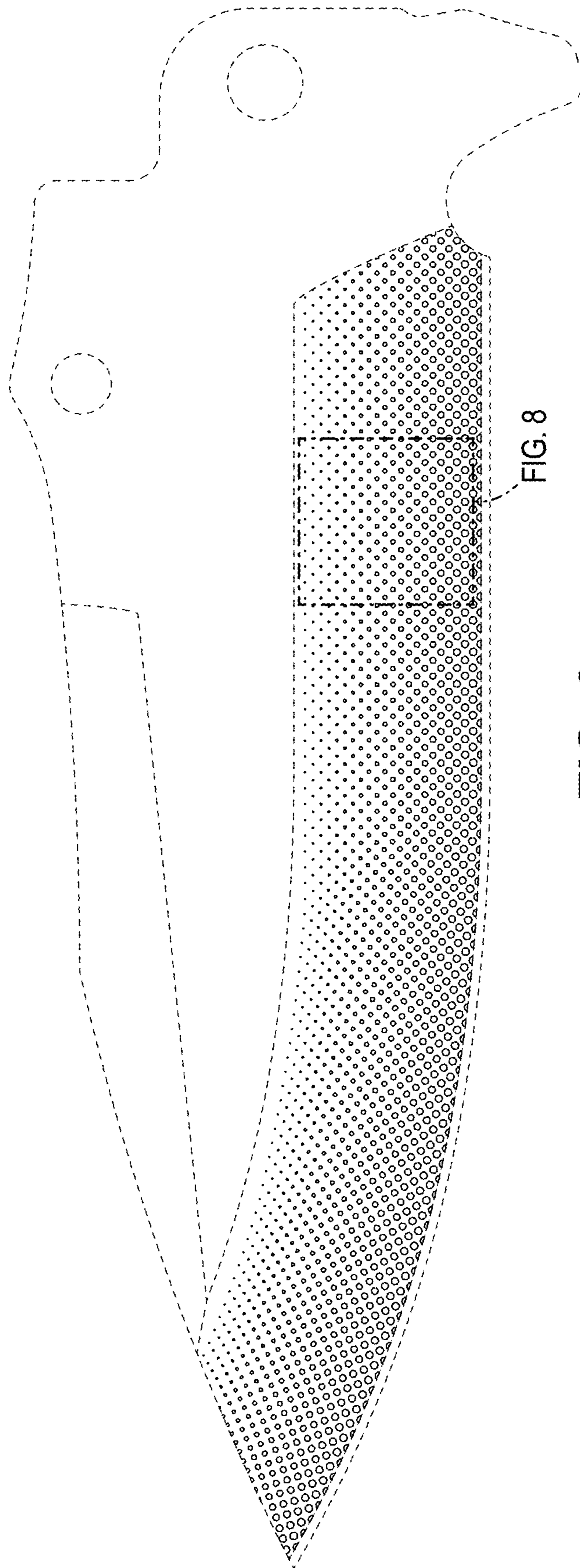

FIG. 2

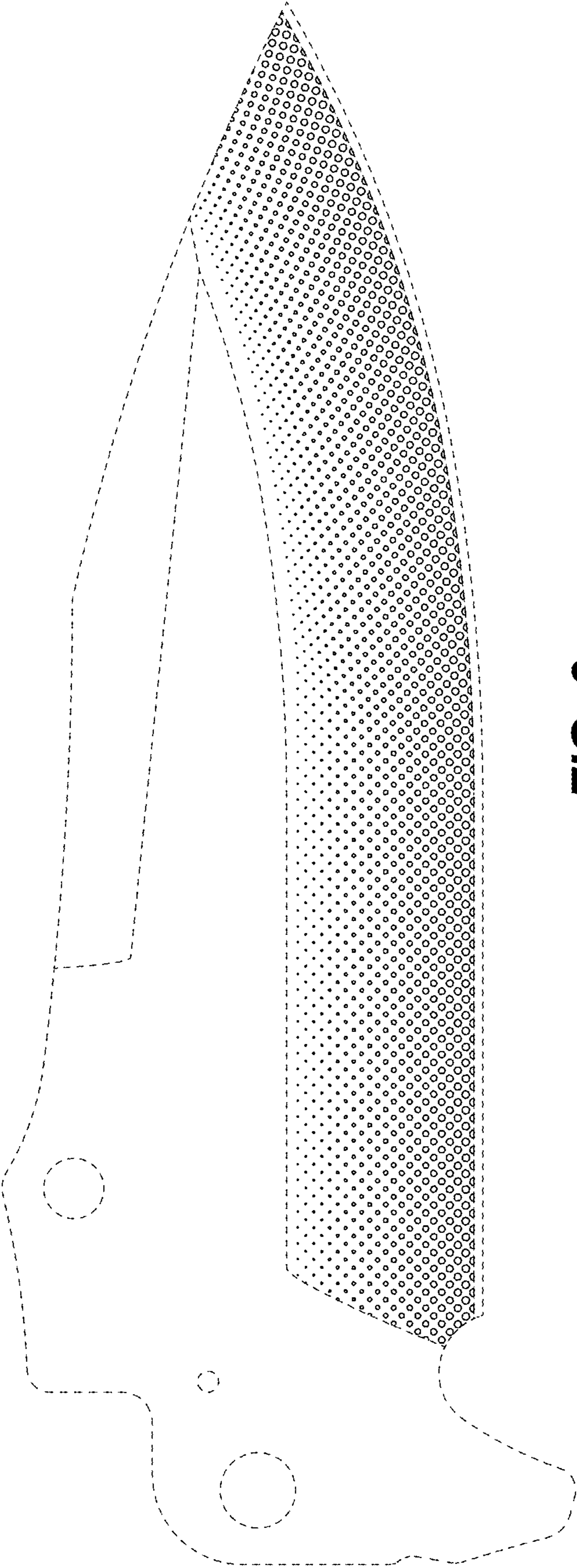

FIG. 3



FIG. 4

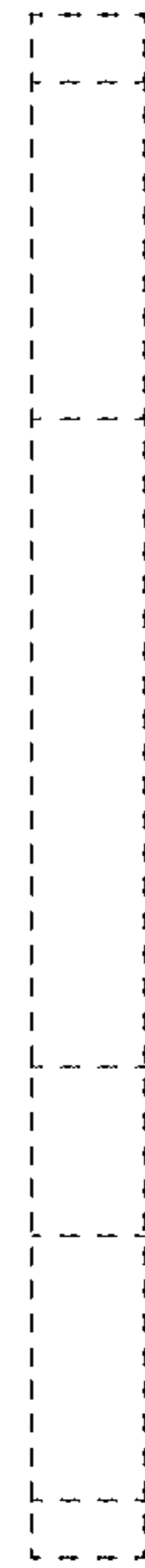

FIG. 5



FIG. 6



FIG. 7

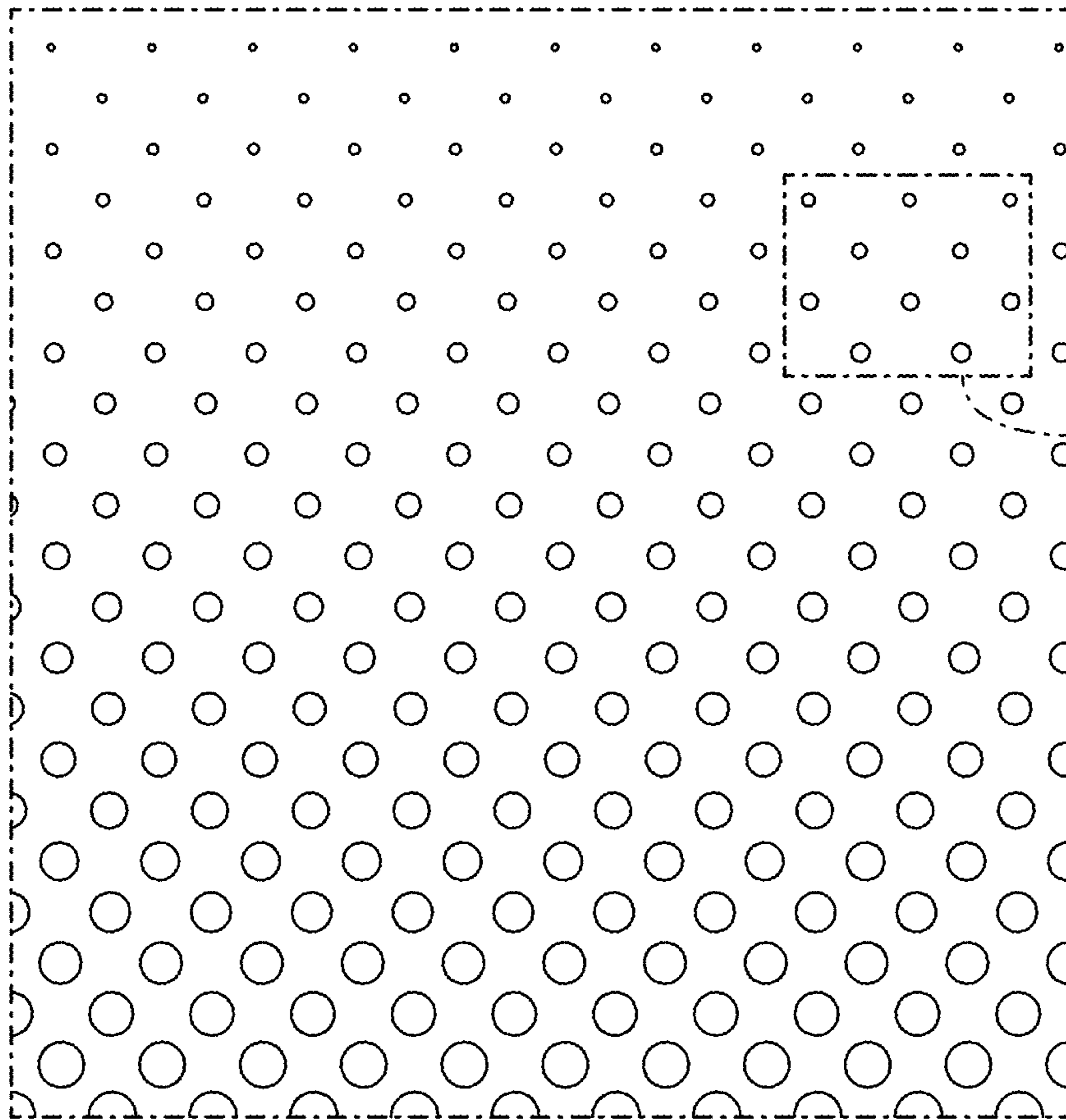

FIG. 9

FIG. 8

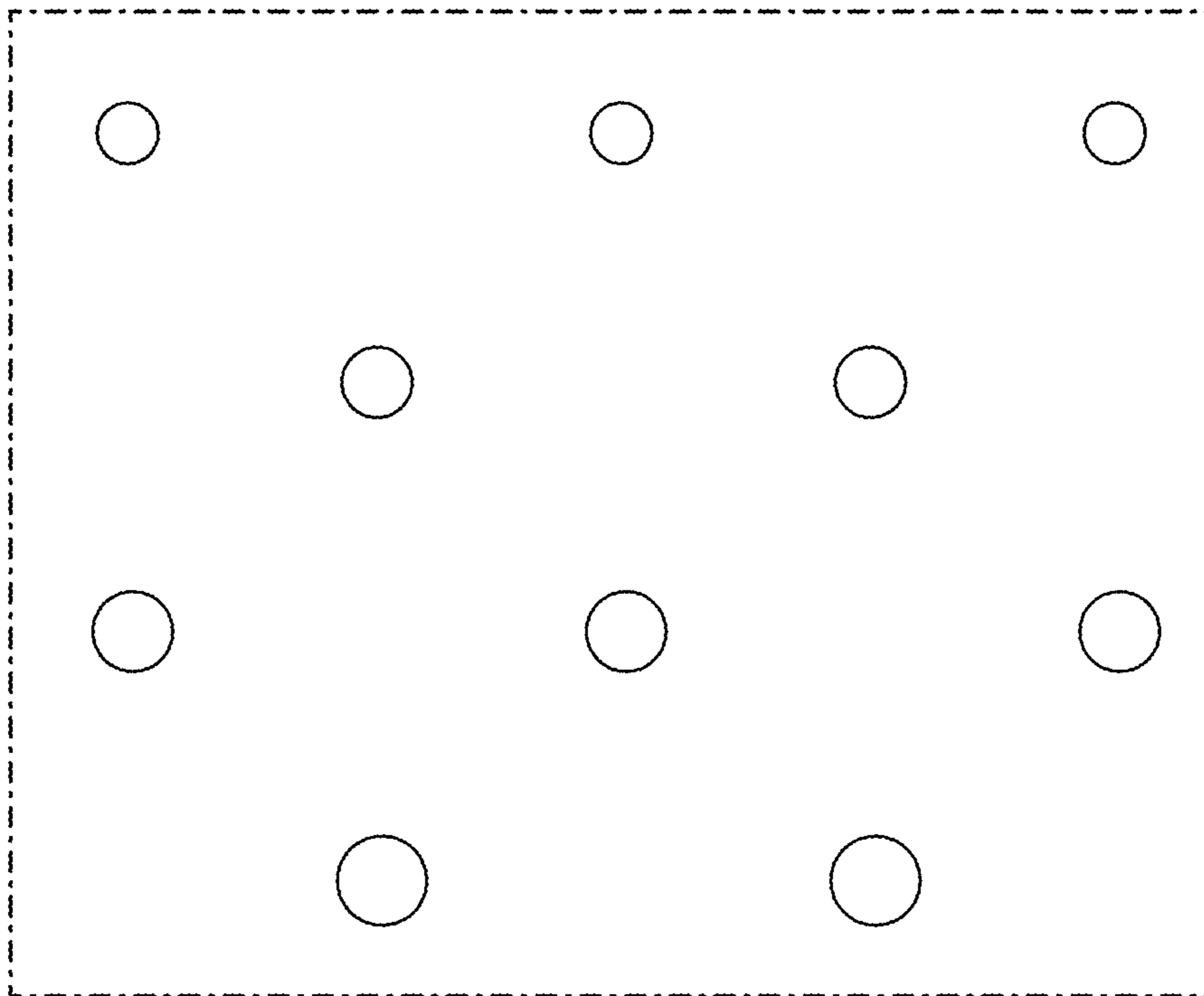

FIG. 9

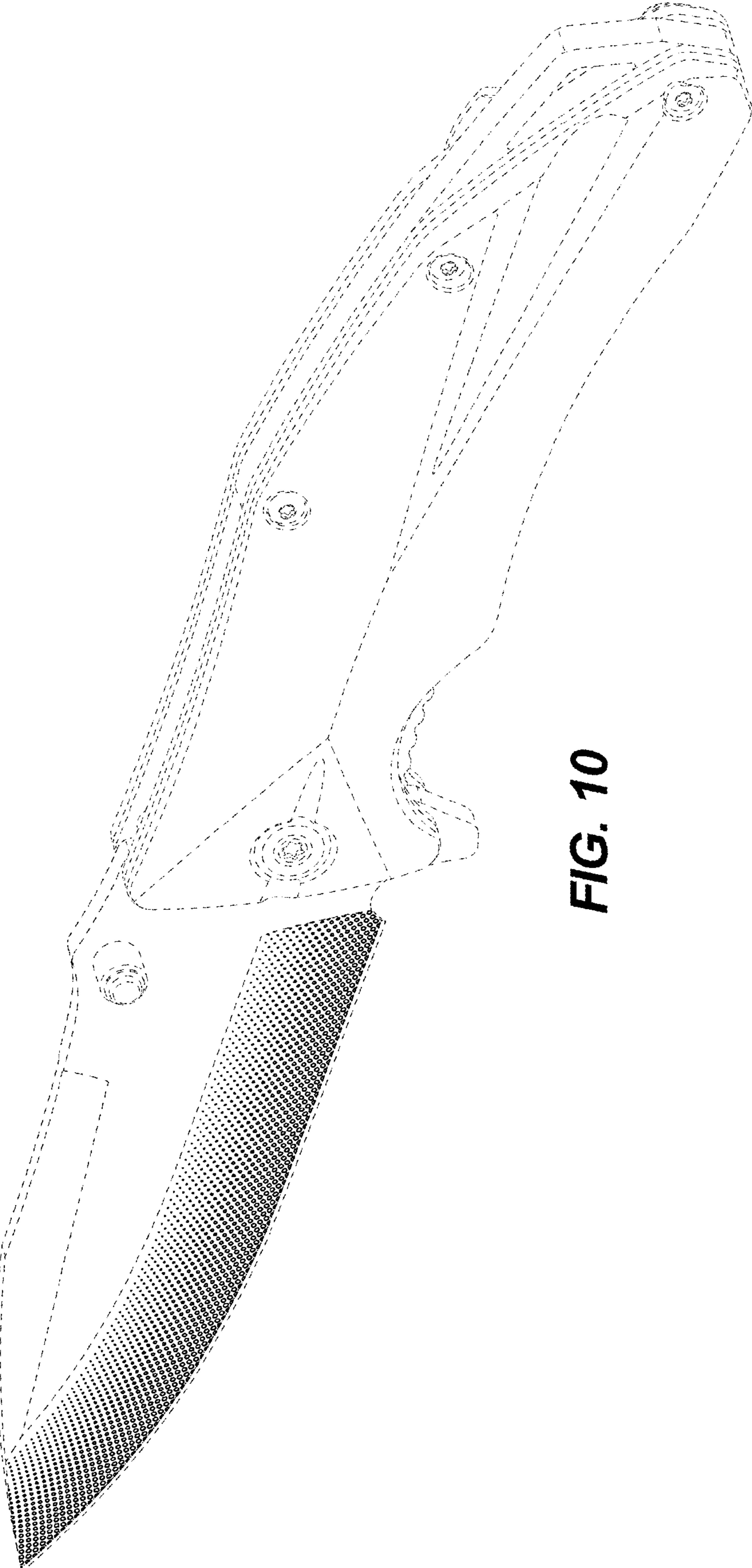

FIG. 10

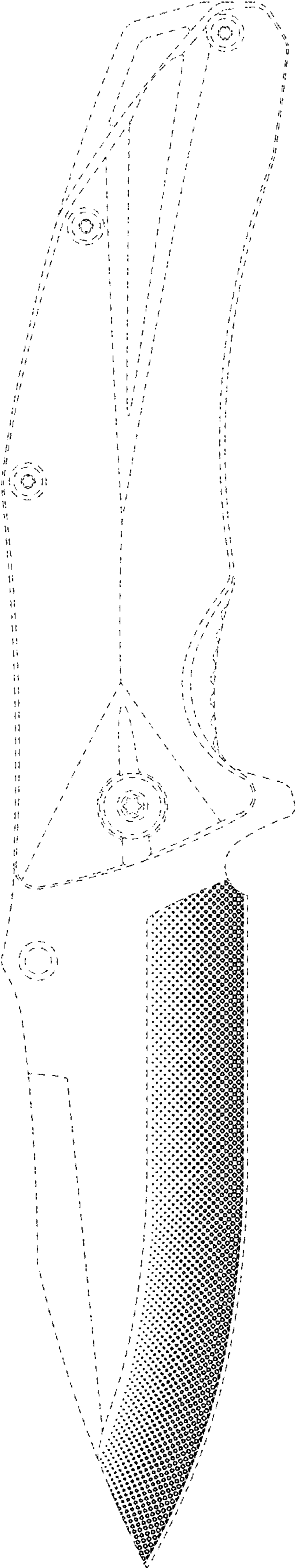

FIG. 11