



US00D917124S

(12) **United States Design Patent** (10) **Patent No.:** **US D917,124 S**  
**Rackers et al.** (45) **Date of Patent:** **\*\* Apr. 20, 2021**

(54) **WHEEL ASSEMBLY WITH REPLACEABLE TIRE**

(71) Applicant: **gowheels, Inc.**, Raleigh, NC (US)

(72) Inventors: **Kevin J. Rackers**, Summerfield, NC (US); **William J. Bateman, Jr.**, Raleigh, NC (US)

(73) Assignee: **gowheels, Inc.**, Raleigh, NC (US)

(\*\*) Term: **15 Years**

(21) Appl. No.: **29/731,159**

(22) Filed: **Apr. 13, 2020**

(51) **LOC (13) Cl.** ..... **12-02**

(52) **U.S. Cl.**  
USPC ..... **D34/27**

(58) **Field of Classification Search**  
USPC ..... **D34/12-27**  
(Continued)

(56) **References Cited**

U.S. PATENT DOCUMENTS

1,665,874 A \* 4/1928 Casler ..... A63C 17/22  
384/546

1,686,301 A 10/1928 Wagenhorst  
(Continued)

FOREIGN PATENT DOCUMENTS

EP 2845748 B1 3/2013

OTHER PUBLICATIONS

Bateman Jr, William, gowheels™—CAD of Removal and Restoration Process, PowerPoint presented to Triangle audience on Nov. 14, 2018 at main conference room of Family Legacy Financial Solutions 2000 Aerial Center Parkway, Suite 112 Morrisville, NC 27560, 10 pages, published by gowheels, Inc. Raleigh, North Carolina, United States of America.

*Primary Examiner* — George A Bugg  
*Assistant Examiner* — Tamara L Hahn  
(74) *Attorney, Agent, or Firm* — Kevin E Flynn; Flynn IP Law

(57) **CLAIM**

The ornamental design for a wheel assembly with replaceable tire, as shown and described.

**DESCRIPTION**

The patent or application file contains at least one drawing executed in color. Copies of this patent or patent application publication with color drawing(s) will be provided by the Office upon request and payment of the necessary fee.

FIG. 1 is a perspective view of front side, right side, and top side of the first embodiment of the claimed design;

FIG. 2 is a perspective view of rear side, left side, and top side of the claimed design of FIG. 1;

FIG. 3 is a top plan view of the claimed design of FIG. 1;

FIG. 4 is a front plan view of the claimed design of FIG. 1;

FIG. 5 is a rear plan view of the claimed design of FIG. 1;

FIG. 6 is a bottom plan view of the claimed design of FIG. 1;

FIG. 7 is a top side and front side perspective view of the claimed design of FIG. 1;

FIG. 8 is a bottom side and back side perspective view of the claimed design of FIG. 1;

FIG. 9 is a perspective view of the left side and rear side of a cross section of the claimed design of FIG. 1;

FIG. 10 is a cross section of the claimed design of FIG. 1;

FIG. 11 is a perspective view of front side, right side, and top side of the second embodiment of the claimed design wherein the hubs are shown in black to show that the hubs are in a contrasting color relative to the adjacent wheel;

FIG. 12 is a perspective view of rear side, left side, and top side of the claimed design of FIG. 11;

FIG. 13 is a top plan view of the claimed design of FIG. 11;

FIG. 14 is a front plan view of the claimed design of FIG. 11;

FIG. 15 is a rear plan view of the claimed design of FIG. 11;

(Continued)

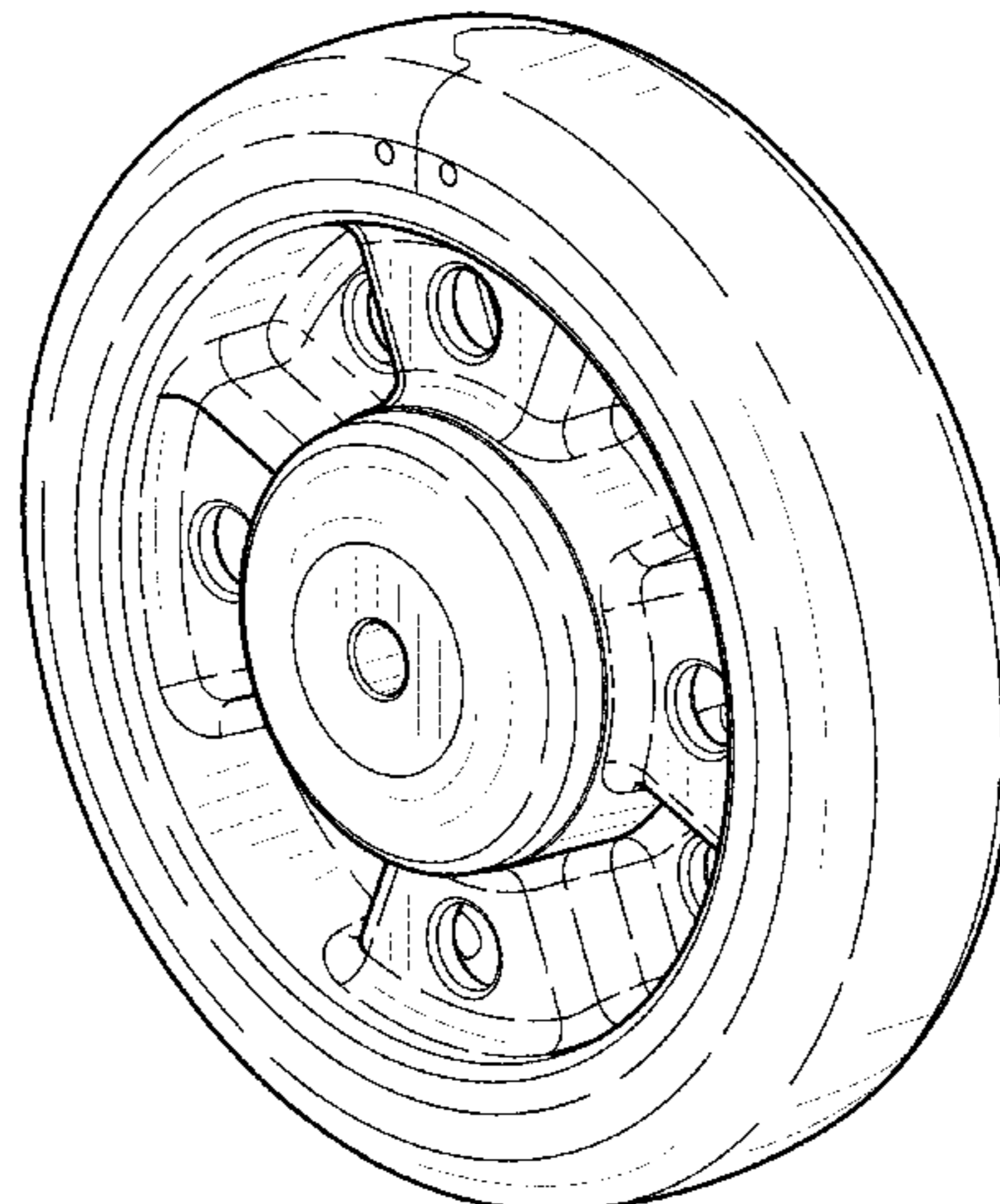

FIG. 16 is a bottom plan view of the claimed design of FIG. 11;  
 FIG. 17 is a top side and front side perspective view of the claimed design of FIG. 11;  
 FIG. 18 is a bottom side and back side perspective view of the claimed design of FIG. 11;  
 FIG. 19 is a perspective view of the left side and rear side of a cross section of the claimed design of FIG. 11;  
 FIG. 20 is a cross section taken from line 20-20 of FIG. 16;  
 FIG. 21 is a perspective view of front side, right side, and top side of the third embodiment of the claimed design wherein the hubs are shown in British racing green;  
 FIG. 22 is a perspective view of rear side, left side, and top side of the claimed design of FIG. 21;  
 FIG. 23 is a top plan view of the claimed design of FIG. 21;  
 FIG. 24 is a front plan view of the claimed design of FIG. 21;  
 FIG. 25 is a rear plan view of the claimed design of FIG. 21;  
 FIG. 26 is a bottom plan view of the claimed design of FIG. 21;  
 FIG. 27 is a top side and front side perspective view of the claimed design of FIG. 21;  
 FIG. 28 is a bottom side and back side perspective view of the claimed design of FIG. 21;  
 FIG. 29 is a perspective view of the left side and rear side of a cross section of the claimed design of FIG. 21; and,  
 FIG. 30 is a cross section of the claimed design of FIG. 21.  
 The broken lines in the drawings depict portions of the wheel assembly with replaceable tire that form no part of the claimed design.

**1 Claim, 21 Drawing Sheets  
 (14 of 21 Drawing Sheet(s) Filed in Color)**

(58) **Field of Classification Search**  
 CPC ..... B60C 15/0226; B60C 7/24; B60C 7/26;  
 B60C 3/00; A63C 17/22; A63C 17/223  
 See application file for complete search history.

(56) **References Cited**  
 U.S. PATENT DOCUMENTS

2,083,766 A 6/1937 Wittkopp  
 4,114,952 A 9/1978 Kimmell

4,923,252 A	5/1990	Plamper et al.	
5,060,706 A	10/1991	Jones et al.	
5,460,433 A	10/1995	Hawley	
5,503,466 A	4/1996	Lew	
5,908,519 A *	6/1999	Piper .....	A63C 17/223 152/165
6,286,572 B1	9/2001	Chen	
6,298,891 B1	10/2001	Harris	
6,467,519 B1	10/2002	Owen	
6,572,198 B1 *	6/2003	Lai .....	A63C 17/22 301/5.301
6,578,930 B1 *	6/2003	Alderman .....	A63C 1/00 280/11.221
6,880,833 B2	4/2005	Polanco	
7,316,252 B1	1/2008	Heard	
7,334,617 B2	2/2008	Hill, III et al.	
7,640,996 B2	1/2010	Moyna	
7,726,370 B2	6/2010	Sauerwald et al.	
7,878,600 B2	2/2011	Krantz	
D640,439 S *	6/2011	Morris .....	D34/27
D649,321 S *	11/2011	Hatcher .....	D34/27
8,292,018 B2	10/2012	Huang	
8,578,984 B2	11/2013	Hannah et al.	
9,067,465 B2 *	6/2015	Erler .....	B60B 1/00
9,090,121 B2	7/2015	Korus et al.	
9,205,702 B2	12/2015	Hannah et al.	
9,358,835 B2	6/2016	McKay	
D796,147 S *	8/2017	Anderson .....	D34/27
9,821,601 B2	11/2017	Korus et al.	
10,219,136 B2	2/2019	Hannah et al.	
10,232,869 B2	3/2019	Carter et al.	
10,457,100 B2	10/2019	Bateman, Jr.	
2003/0015908 A1 *	1/2003	Young .....	A63C 17/223 301/5.309
2005/0257871 A1	11/2005	Hill, III et al.	
2007/0063573 A1	3/2007	Szabo et al.	
2007/0240800 A1	10/2007	Sauerwald et al.	
2008/0143070 A1	6/2008	Sonnendorfer et al.	
2008/0179940 A1	7/2008	Hill et al.	
2009/0095496 A1	4/2009	Moyna	
2010/0052412 A1	3/2010	Morris	
2013/0284860 A1	10/2013	Korus et al.	
2015/0083295 A1	3/2015	Rogrigo	
2015/0284016 A1 *	10/2015	Berlinger .....	B62B 1/12 280/47.18
2016/0075176 A1	3/2016	Solheim et al.	
2016/0144709 A1	5/2016	Block	
2016/0200143 A1	7/2016	Korus et al.	
2019/0016176 A1 *	1/2019	Johnson .....	B60B 3/08

\* cited by examiner

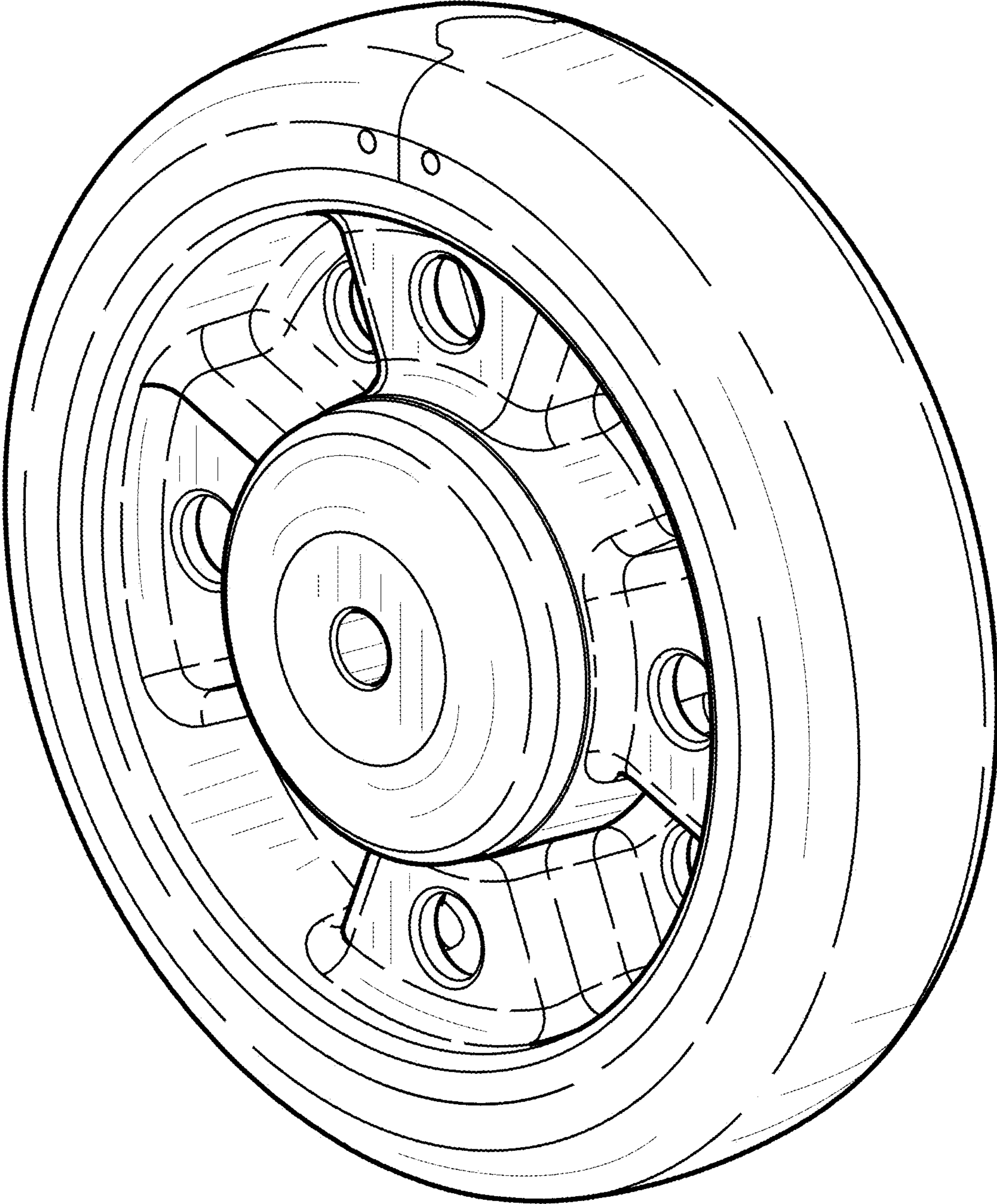

FIG. 1

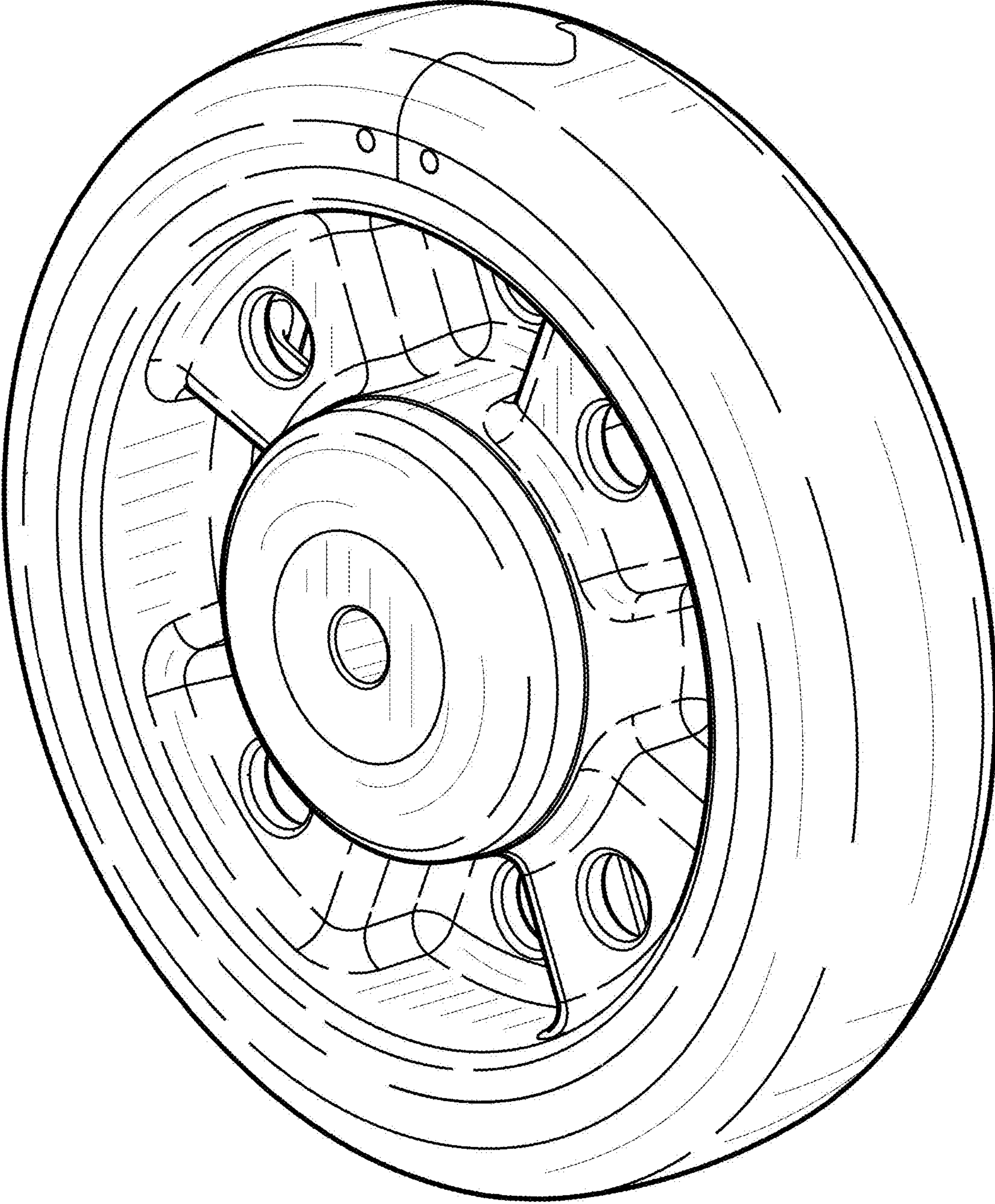

FIG. 2

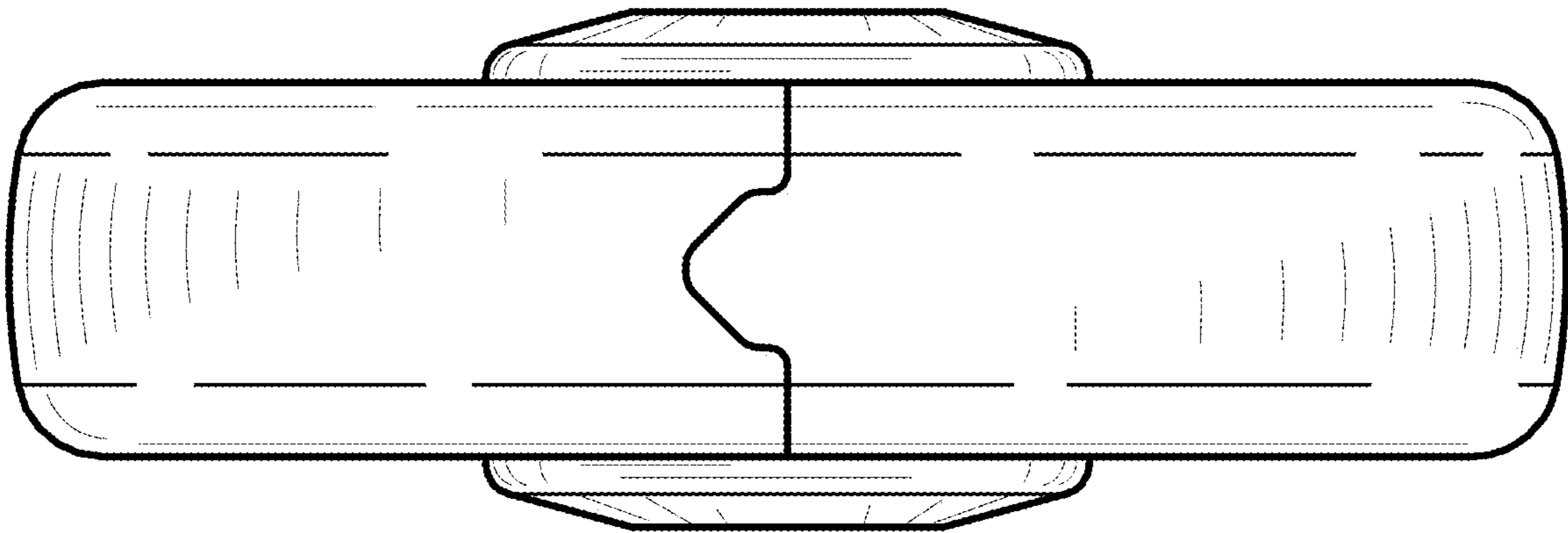

FIG. 3

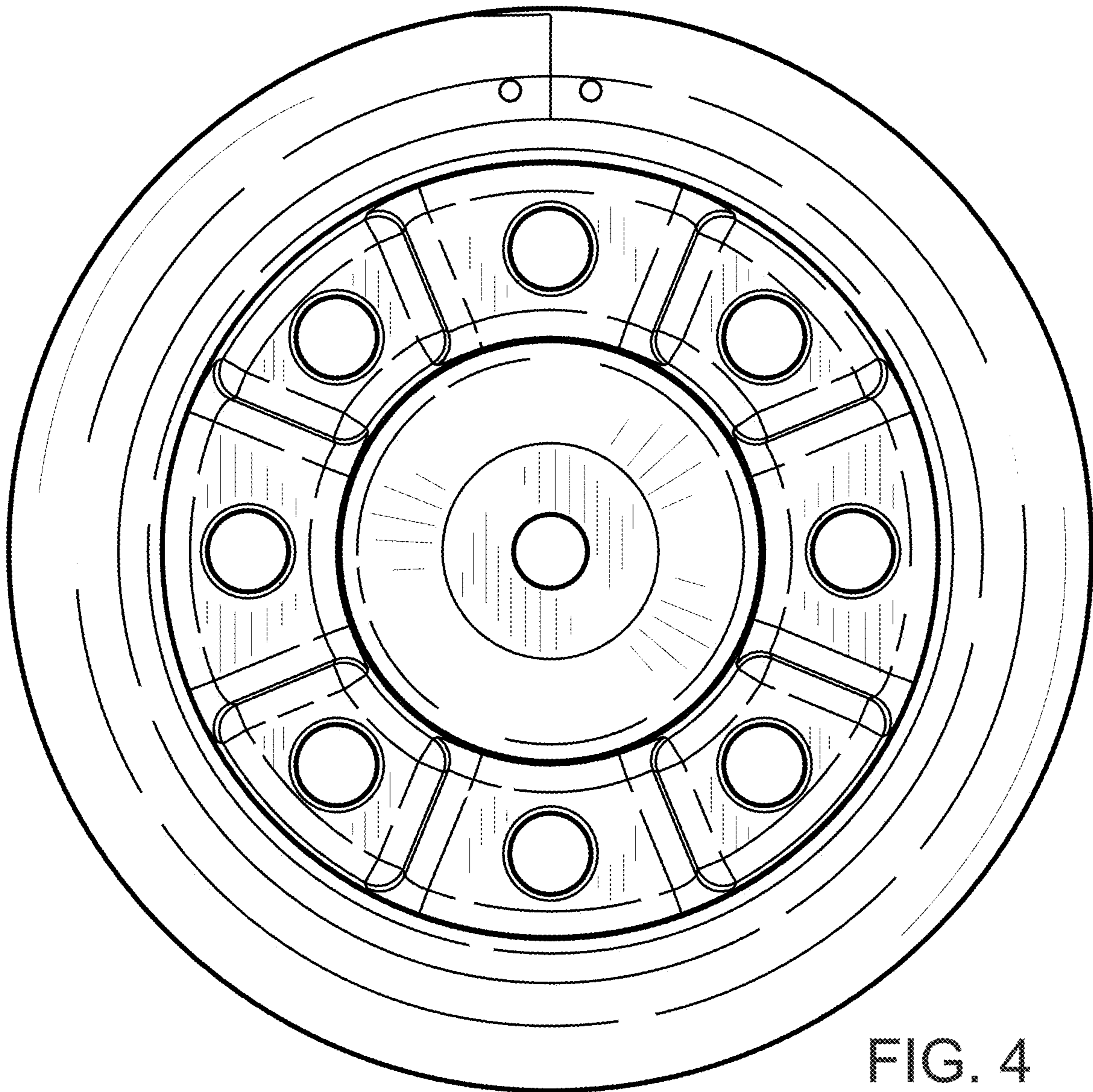

FIG. 4

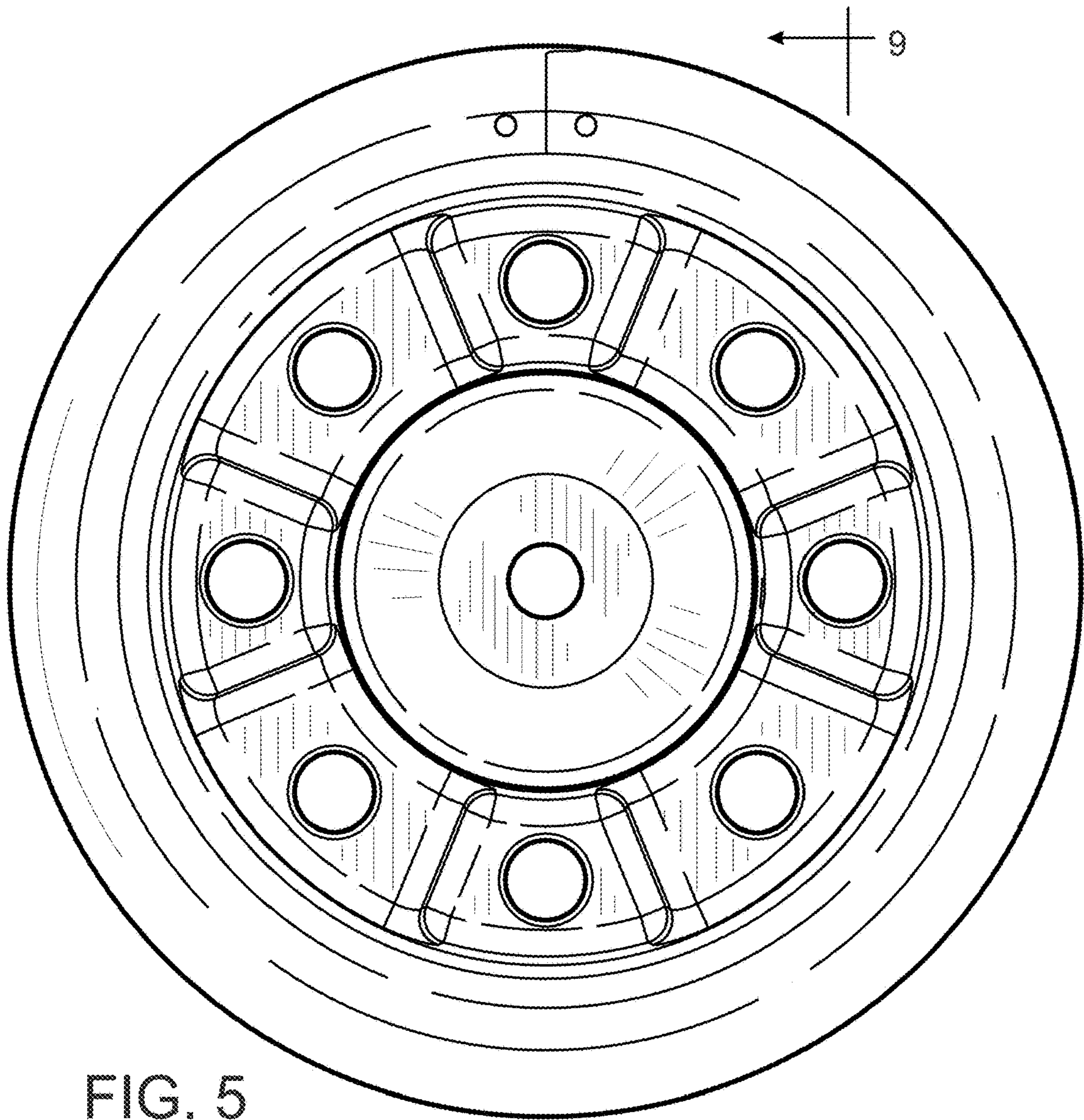

FIG. 5

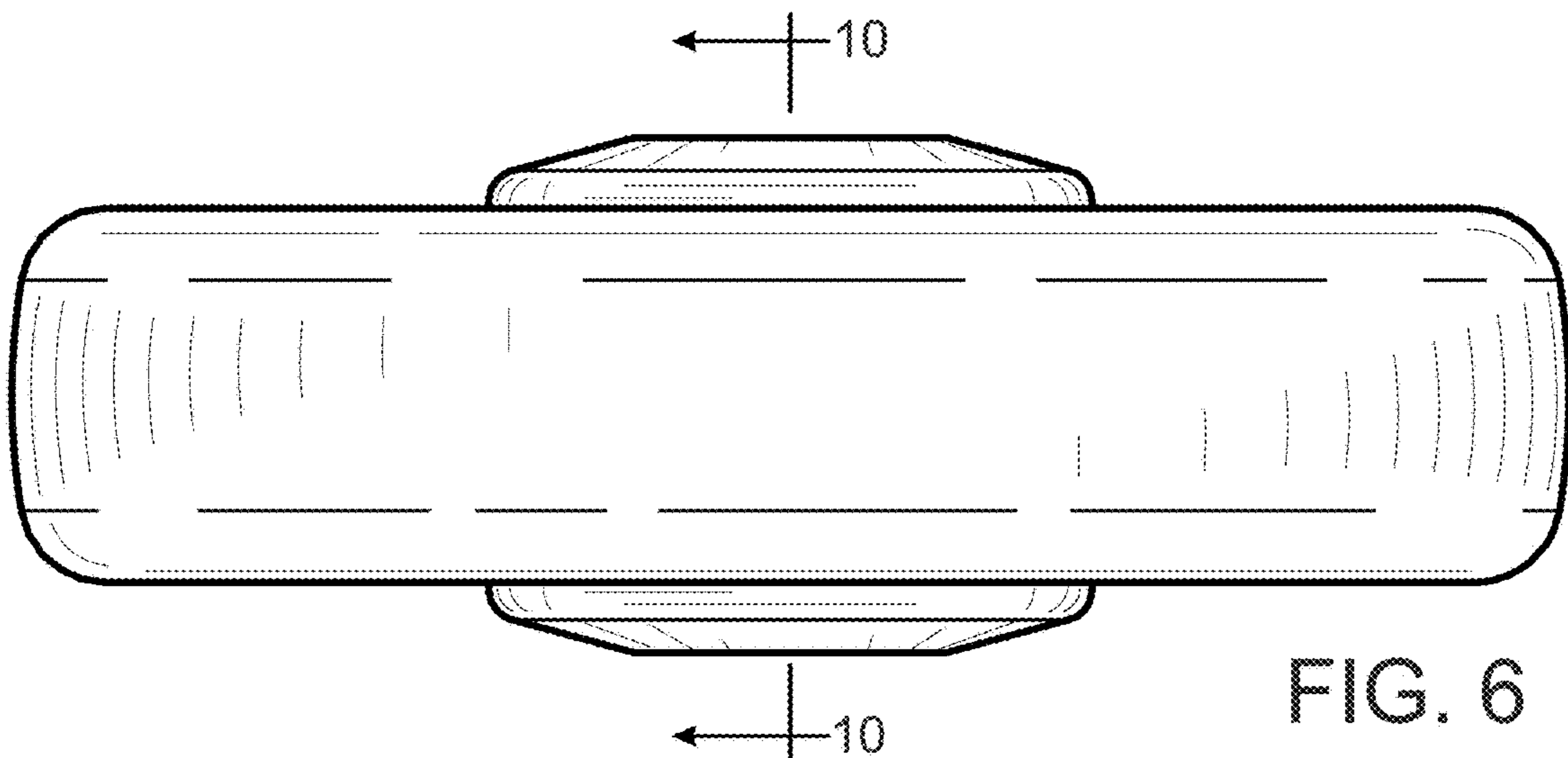

FIG. 6

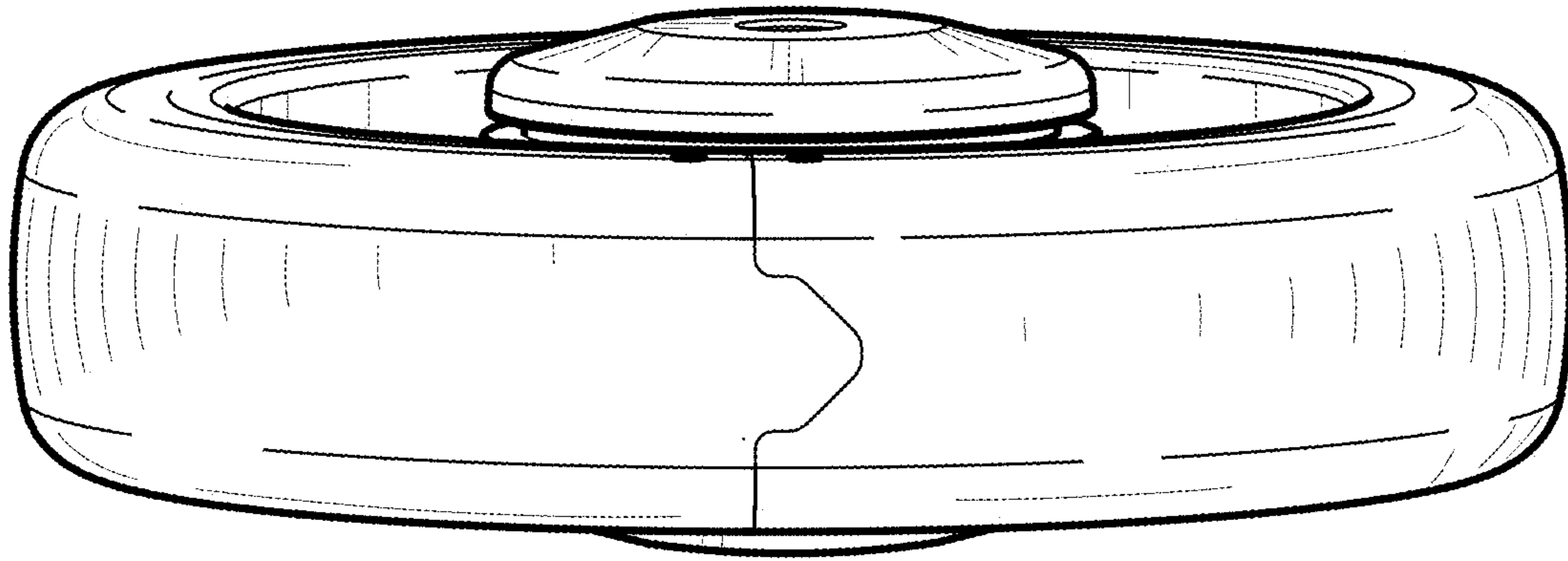

FIG. 7

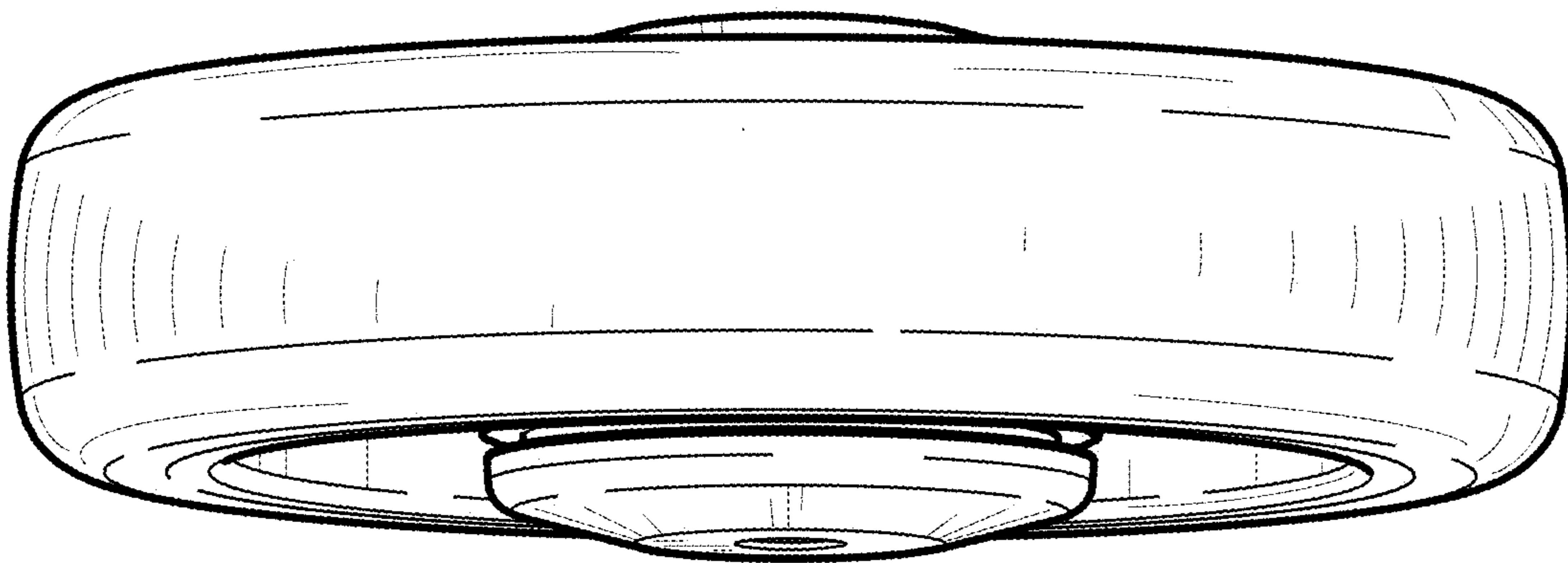

FIG. 8

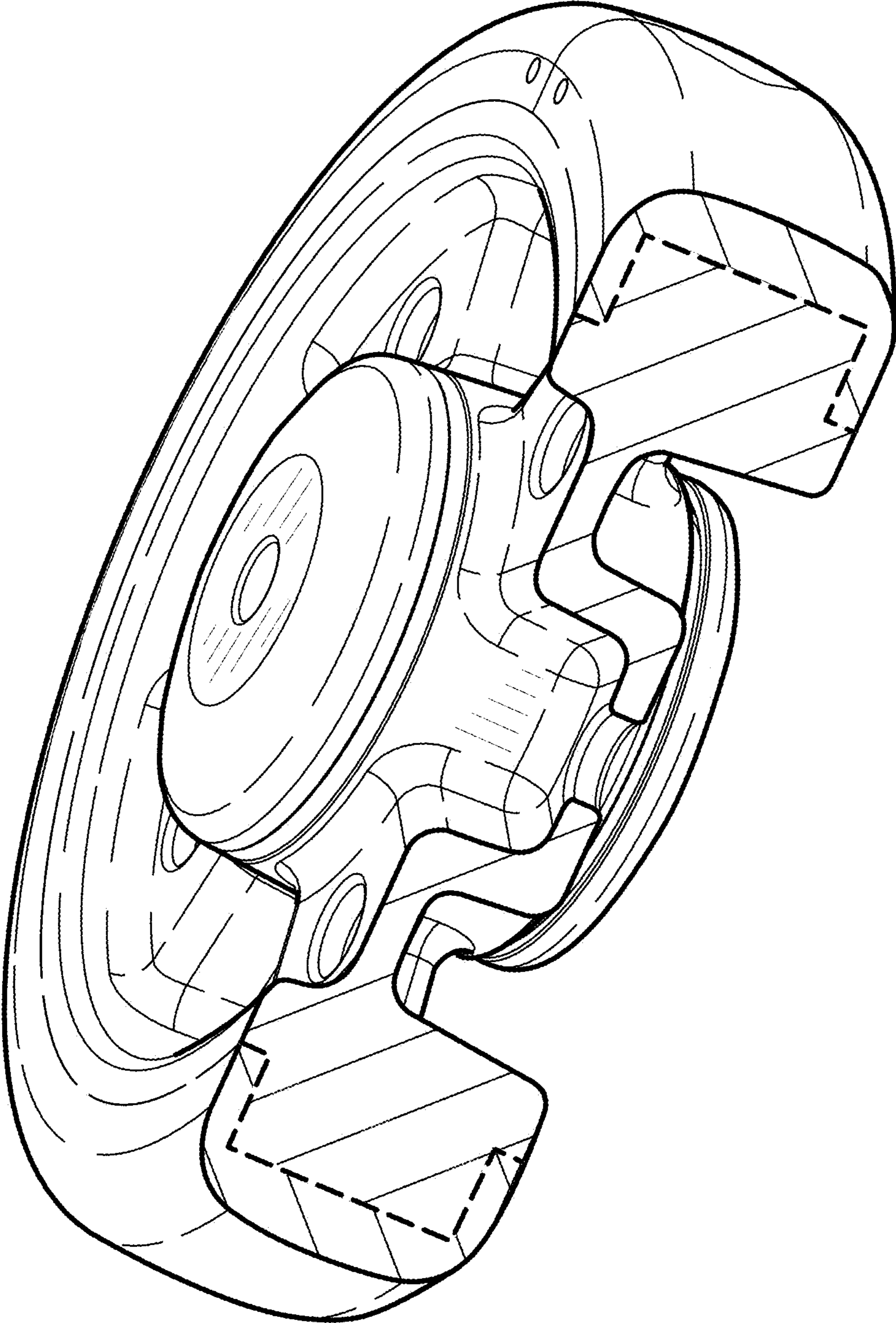

FIG. 9



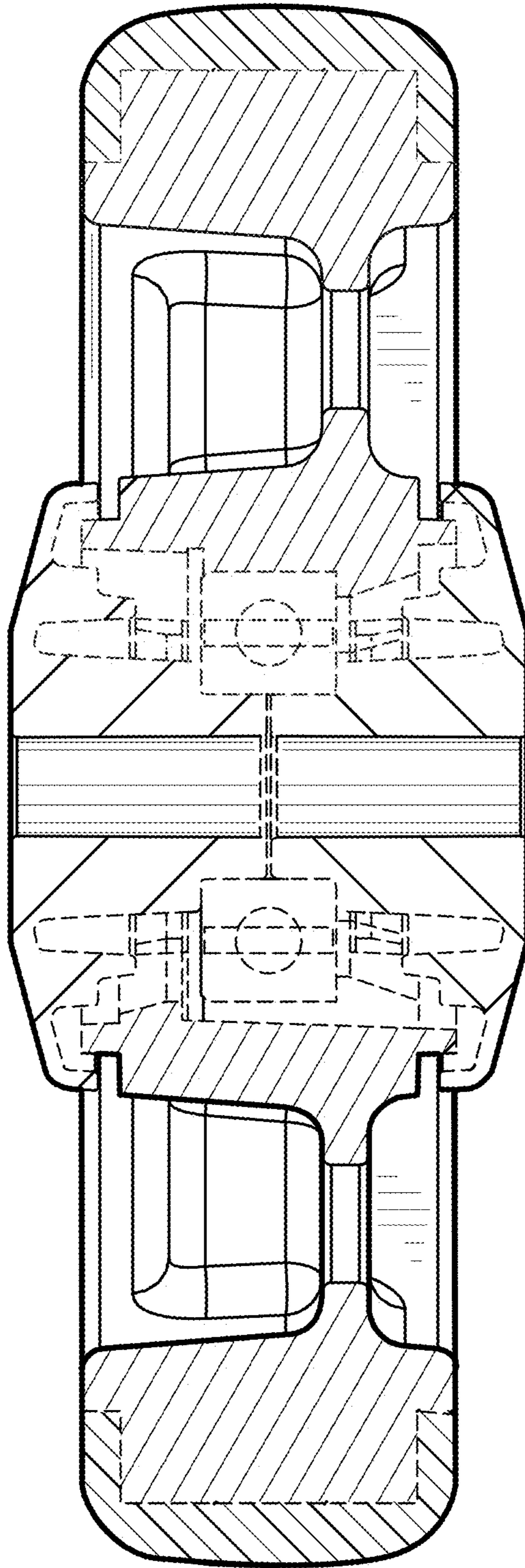

FIG. 10

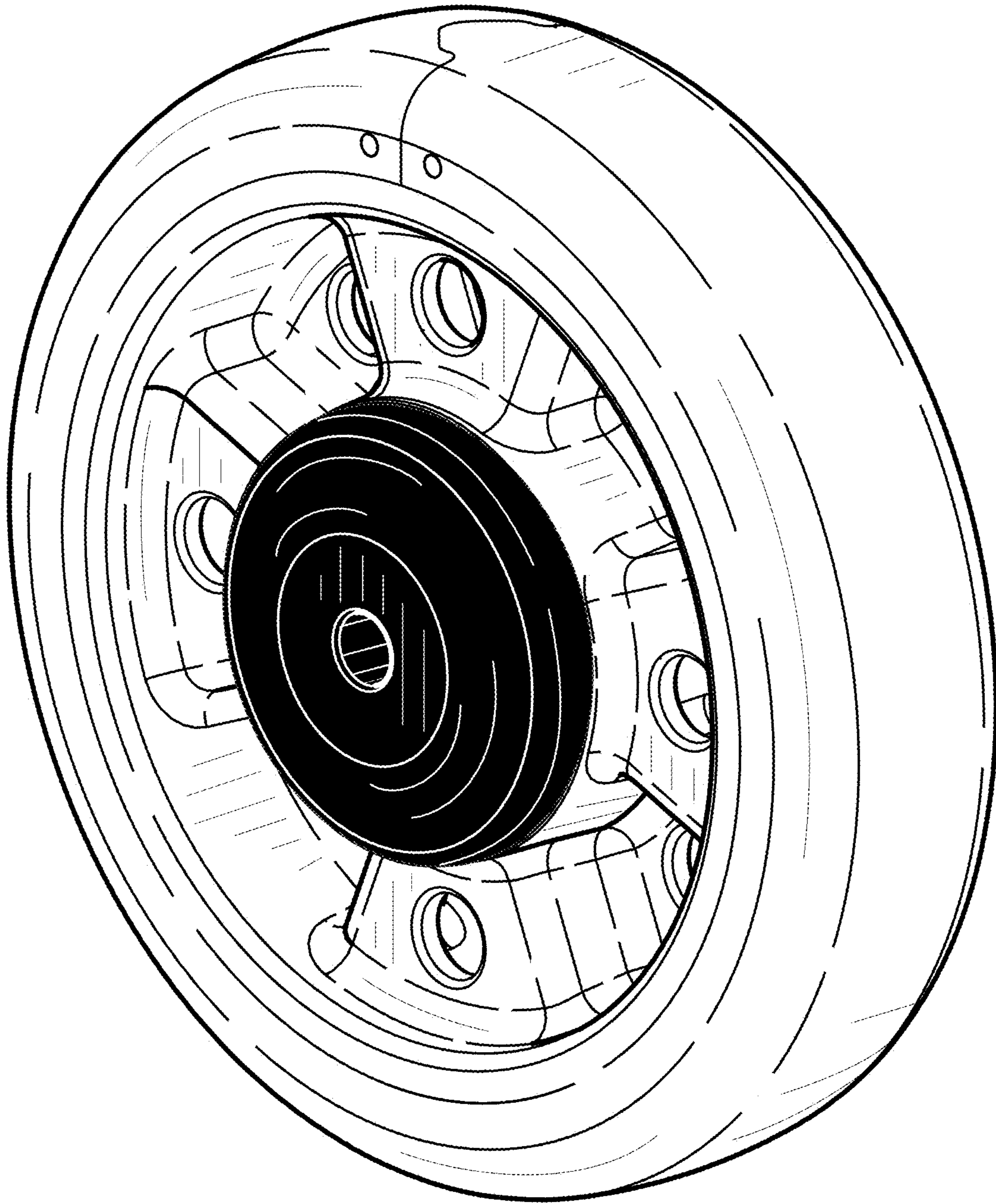

FIG. 11

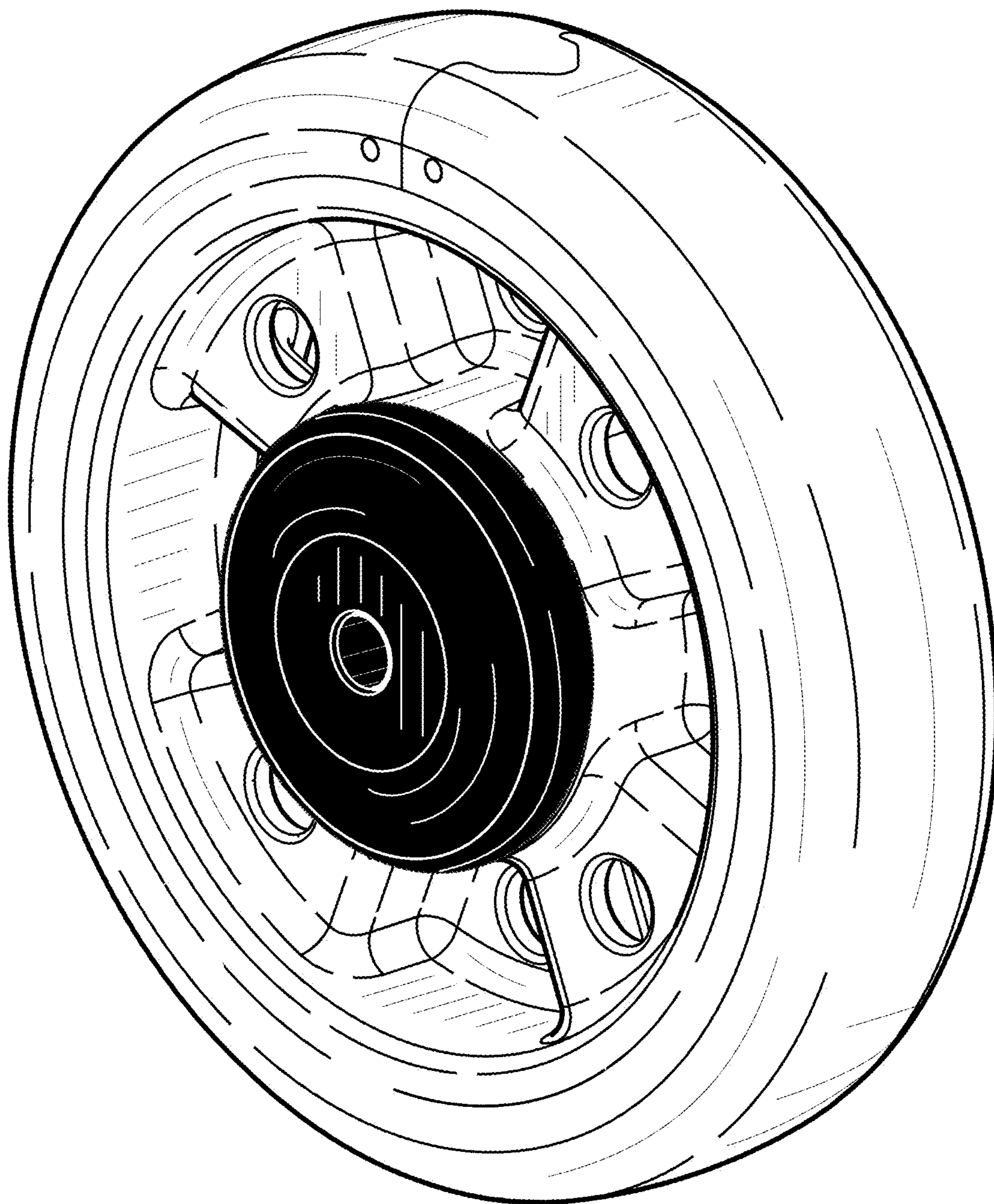

FIG. 12

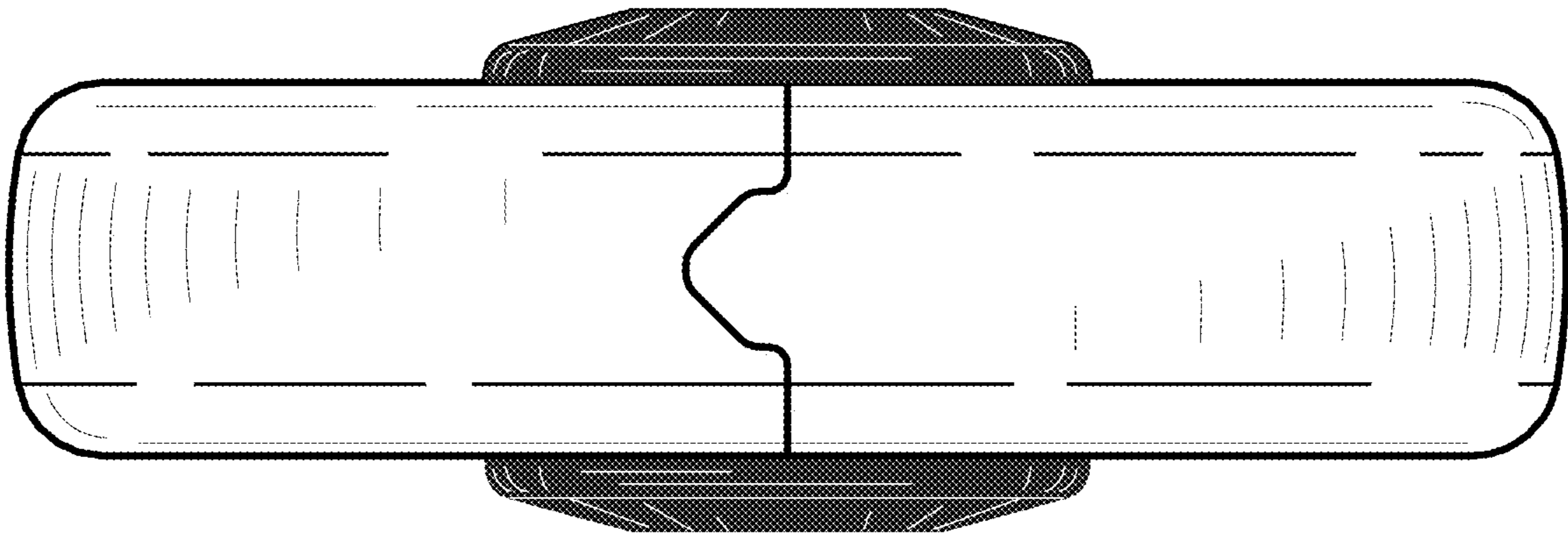

FIG. 13

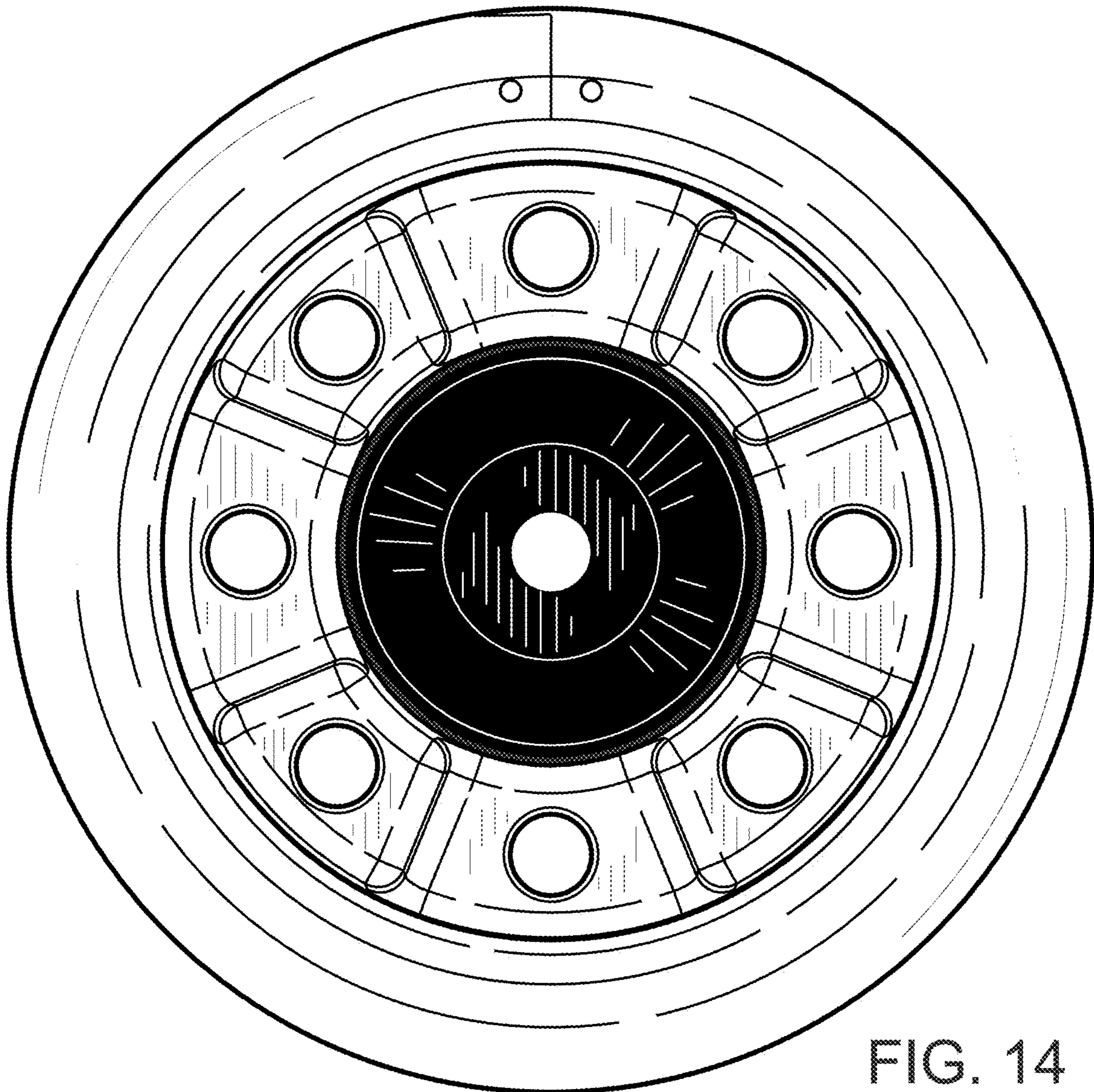

FIG. 14

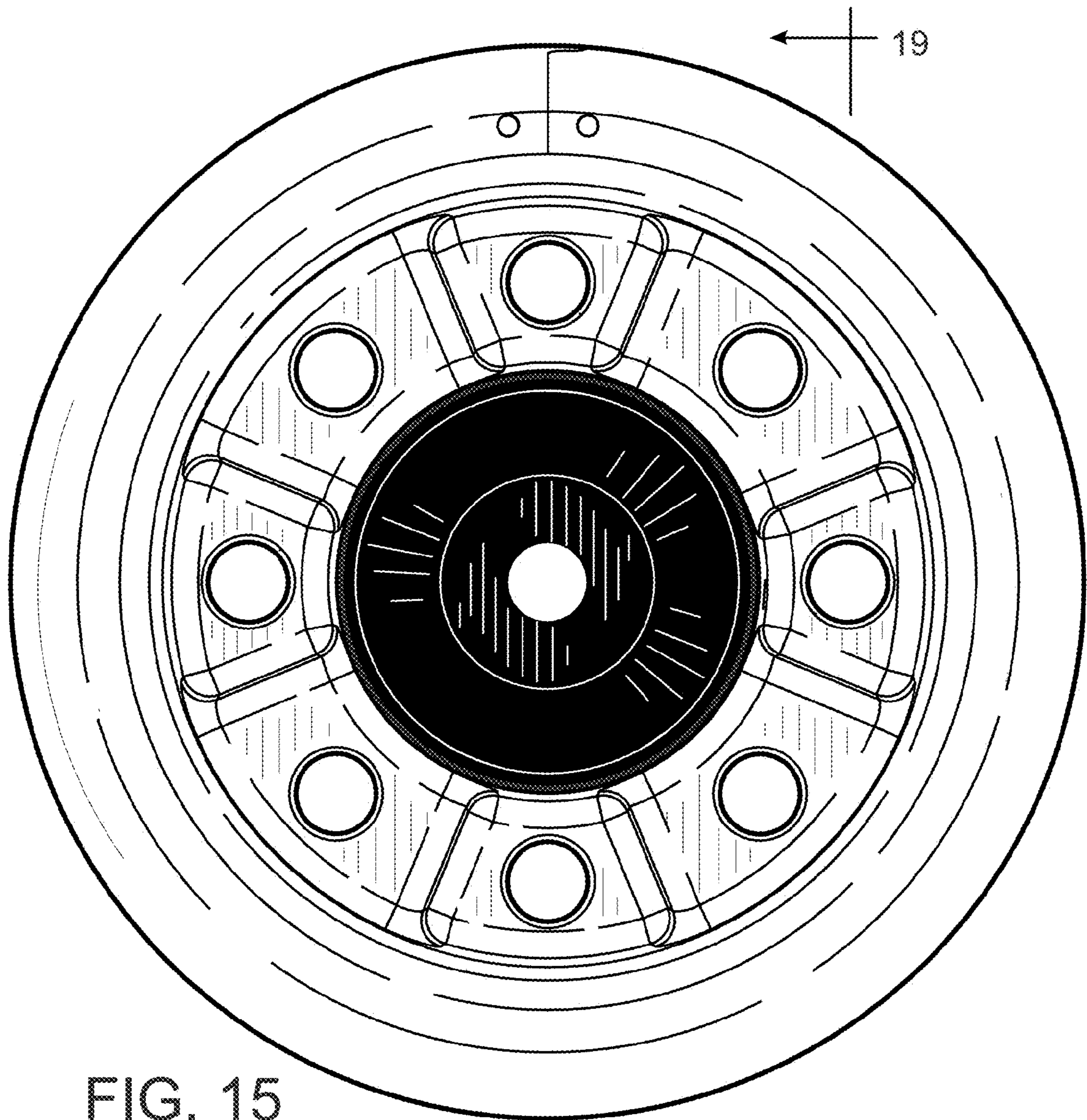

FIG. 15

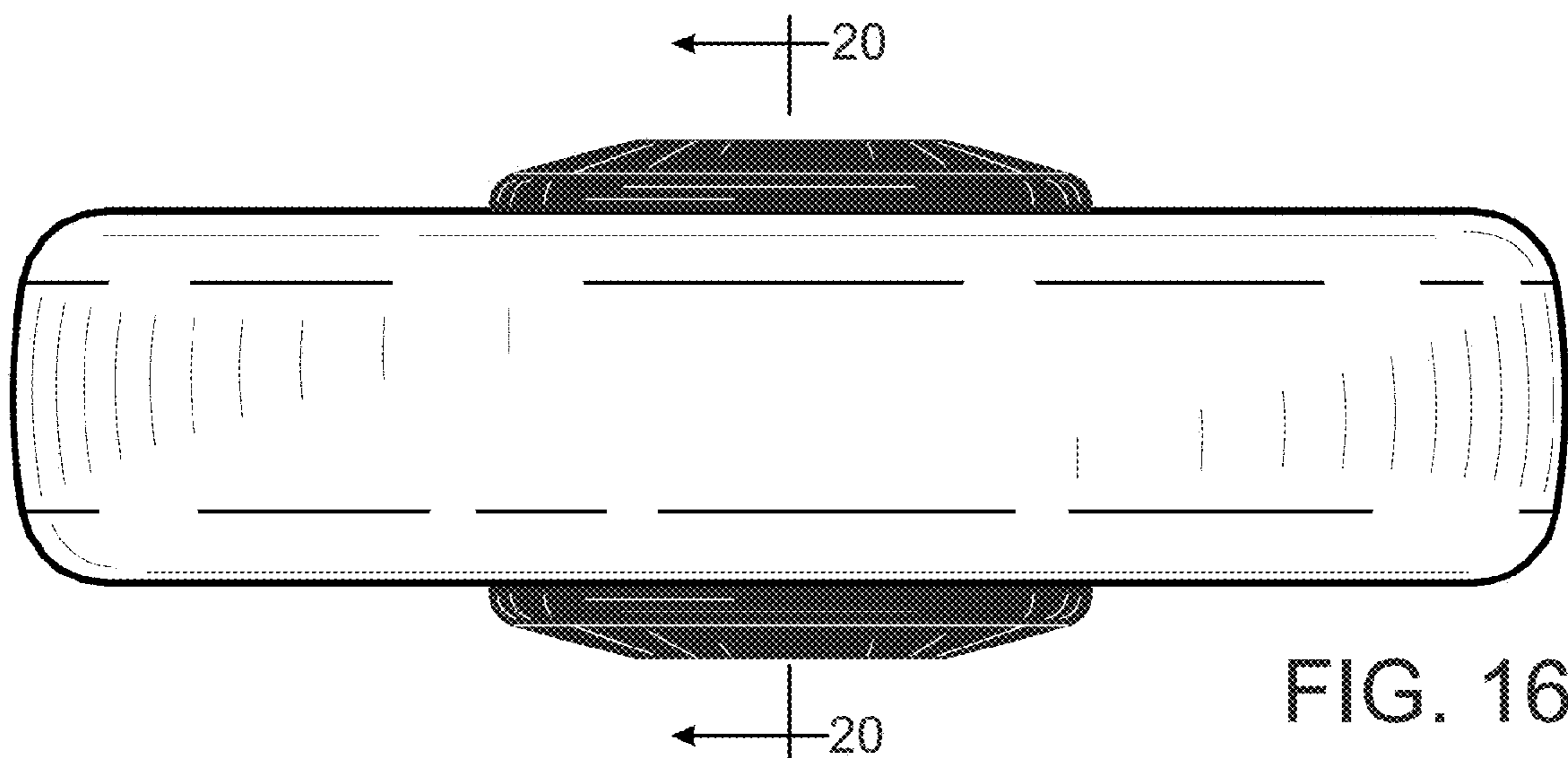

FIG. 16

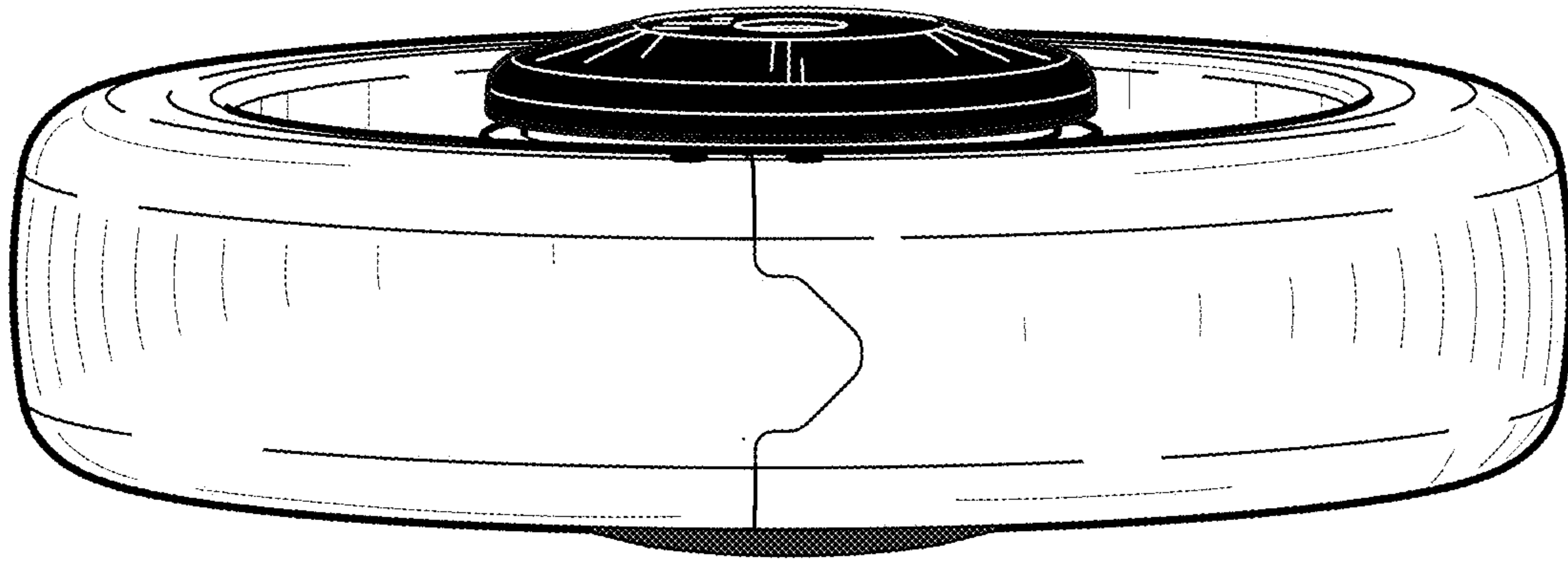

FIG. 17

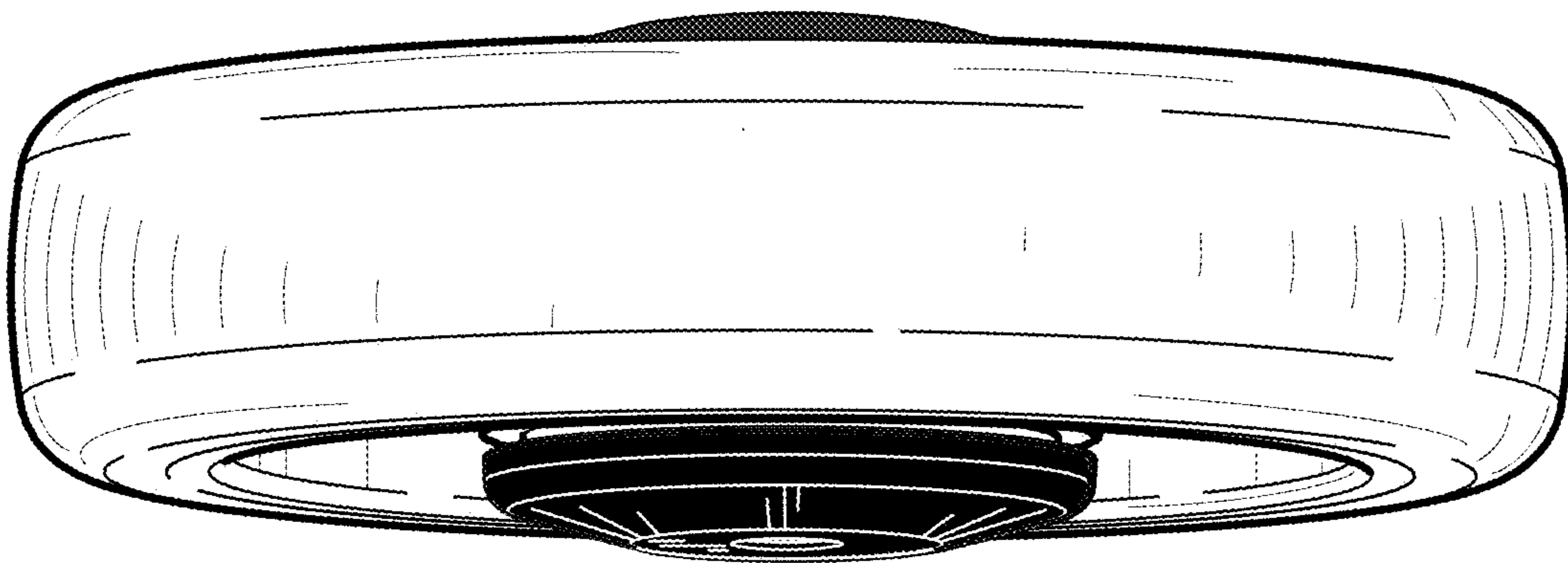

FIG. 18

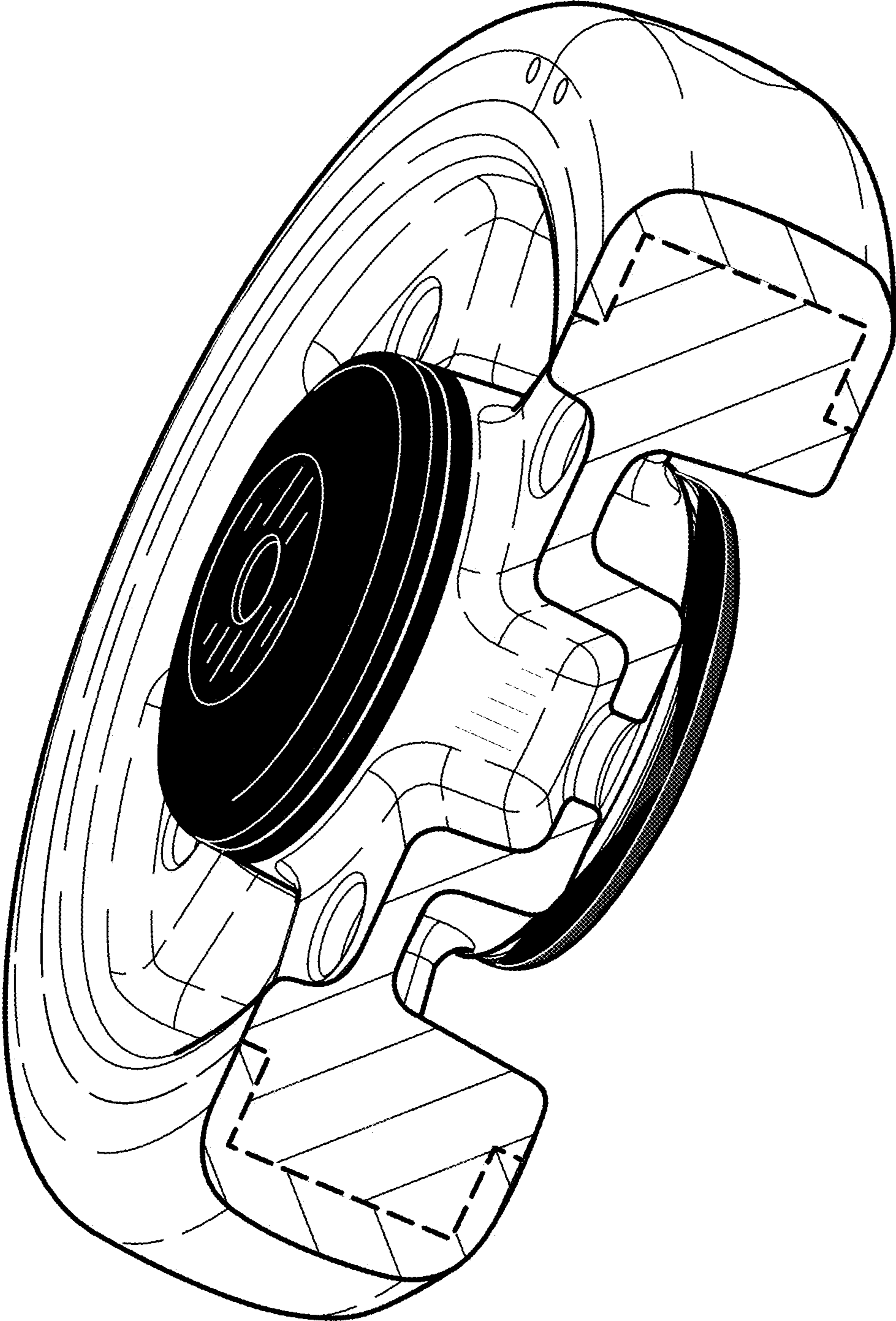

FIG. 19

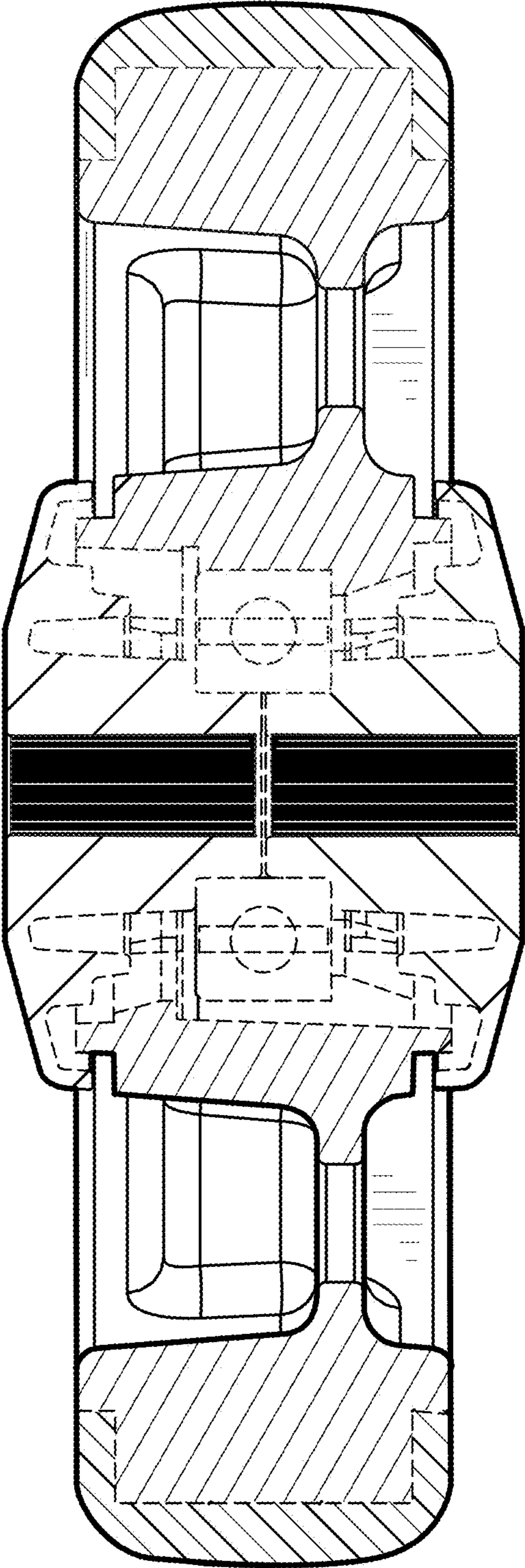

FIG. 20



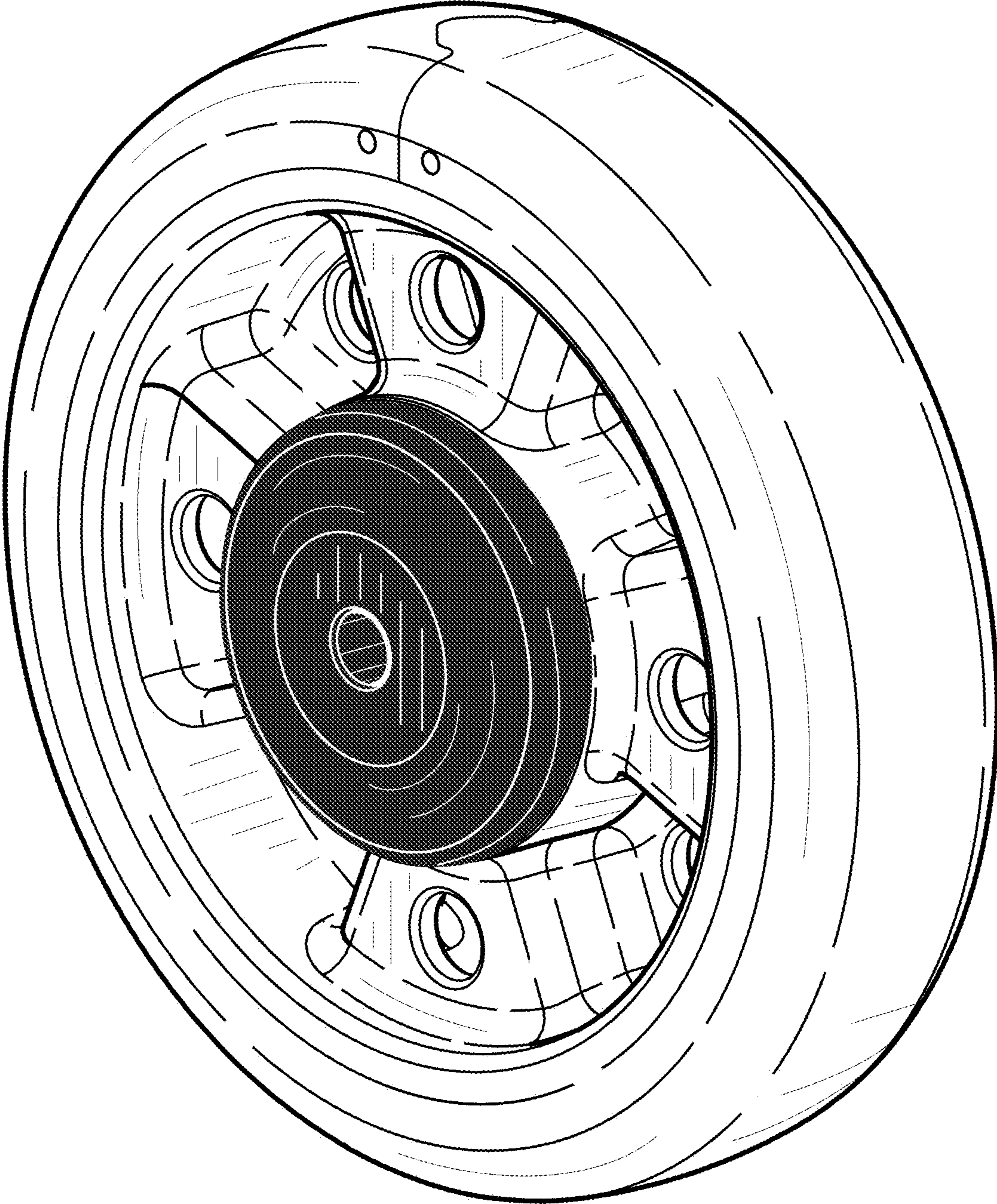

FIG. 21

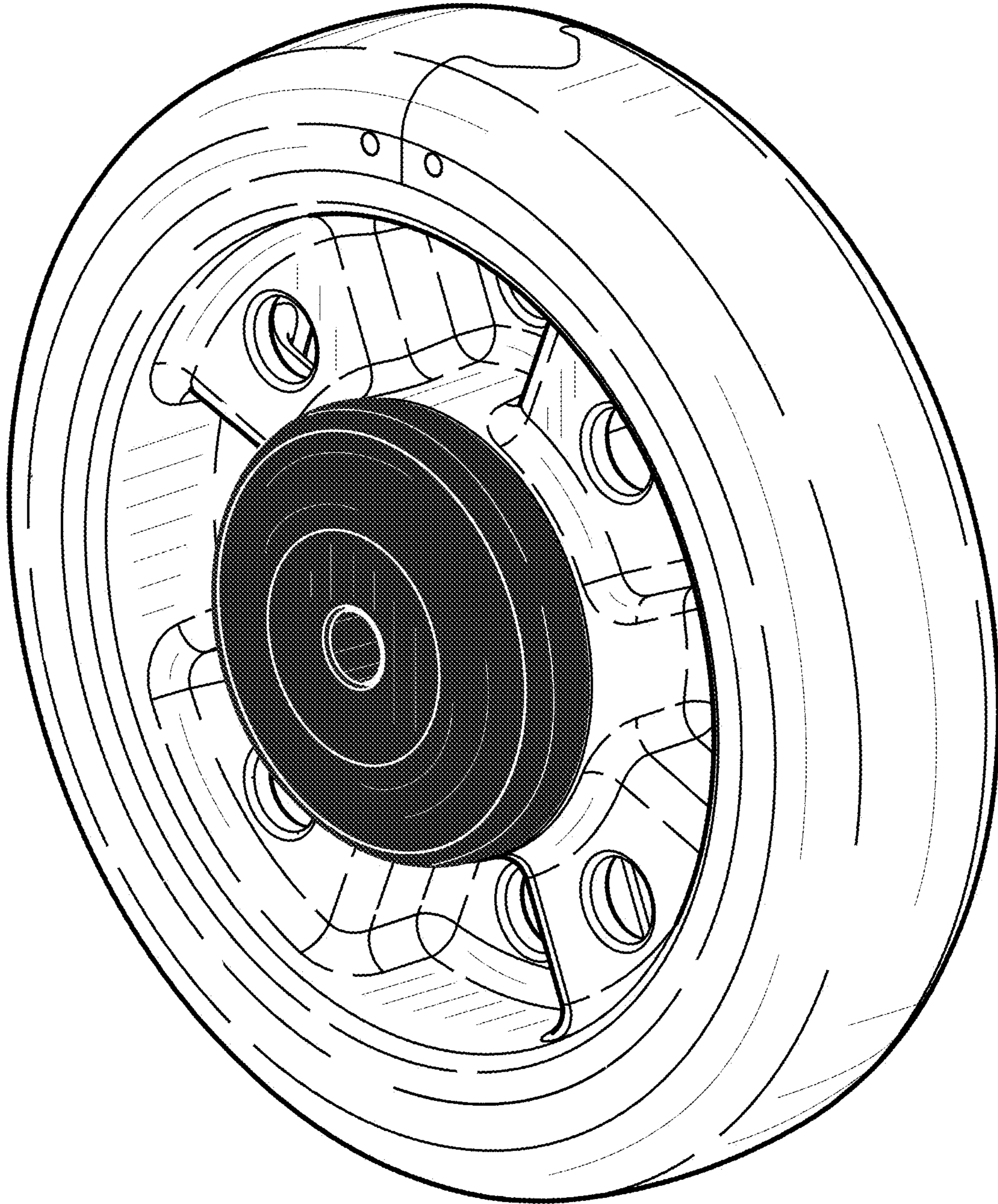

FIG. 22

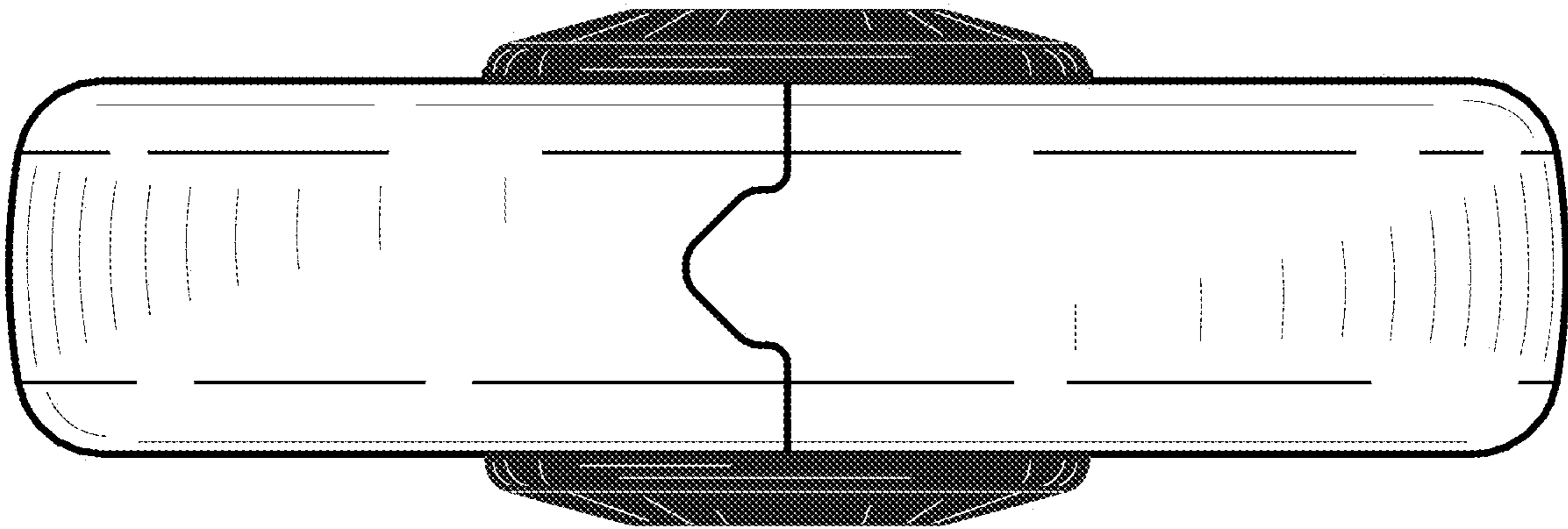

FIG. 23

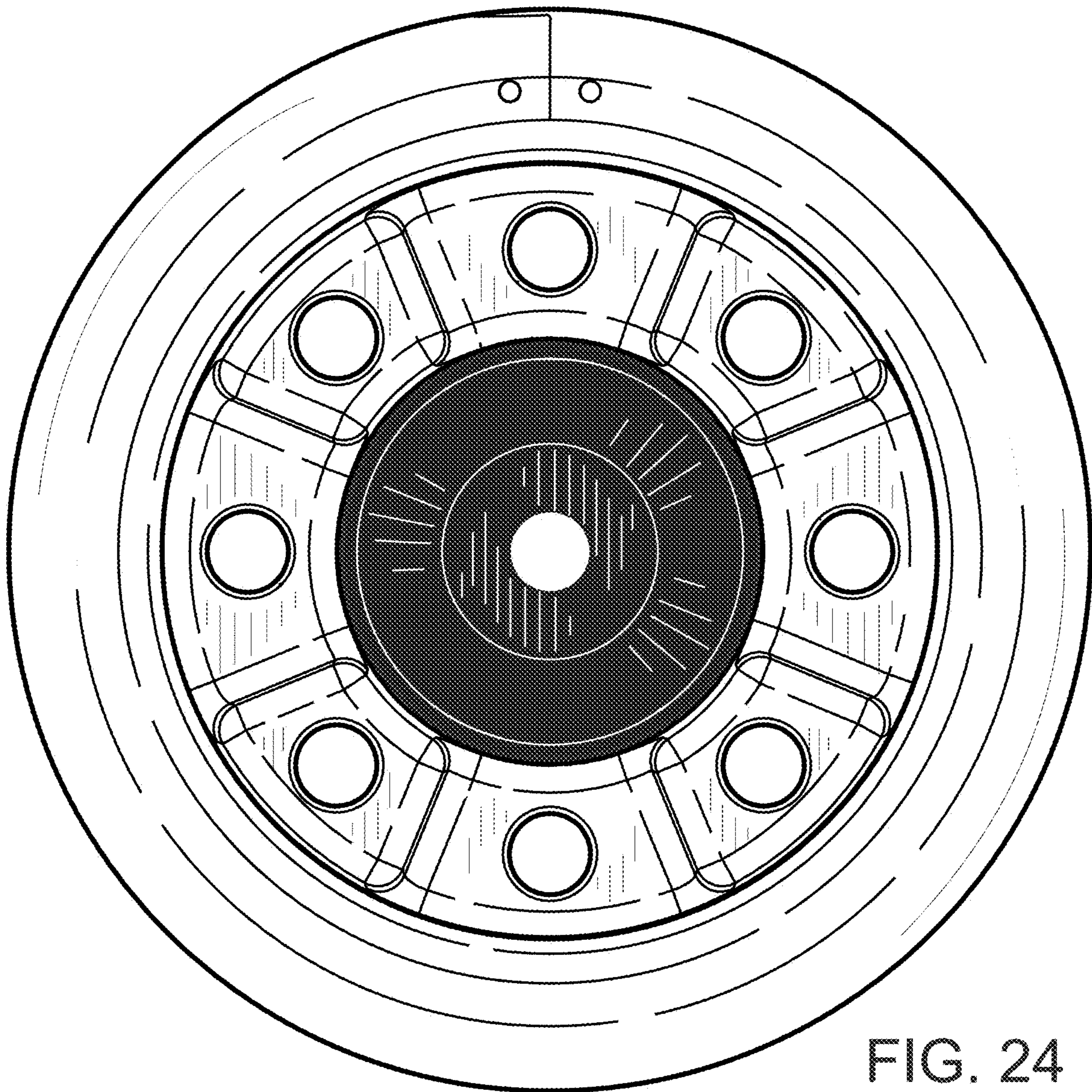

FIG. 24

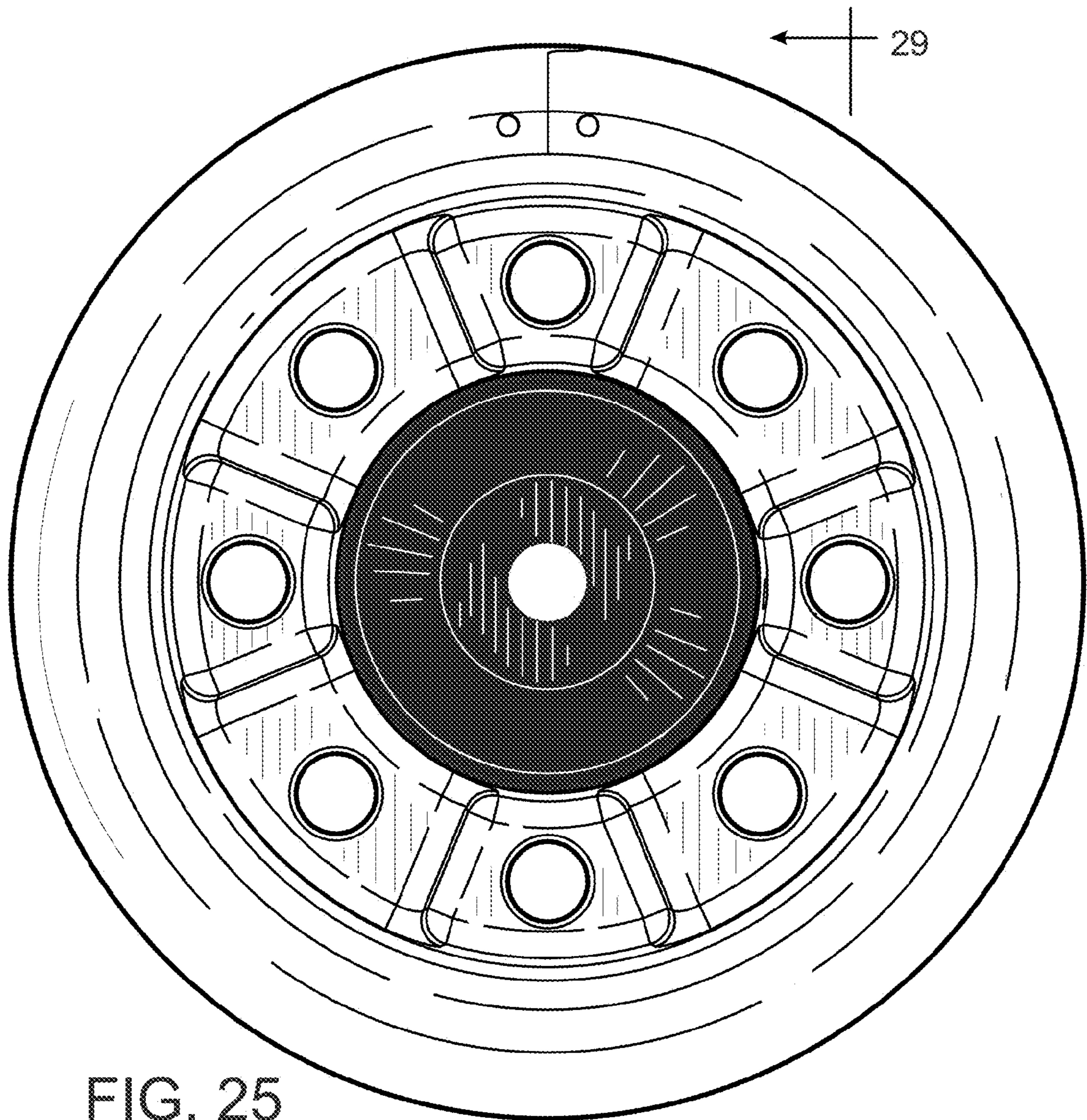

FIG. 25

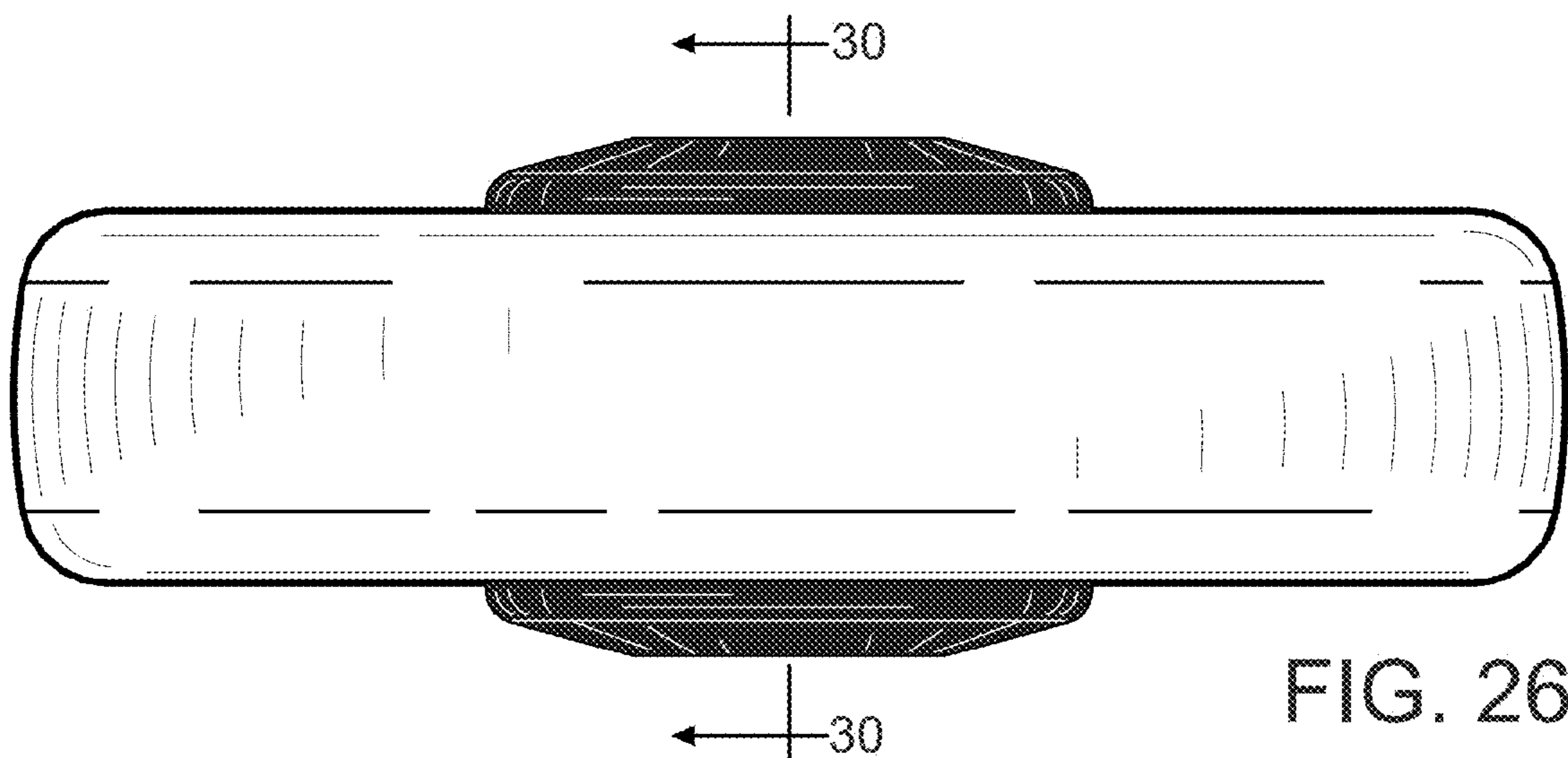

FIG. 26

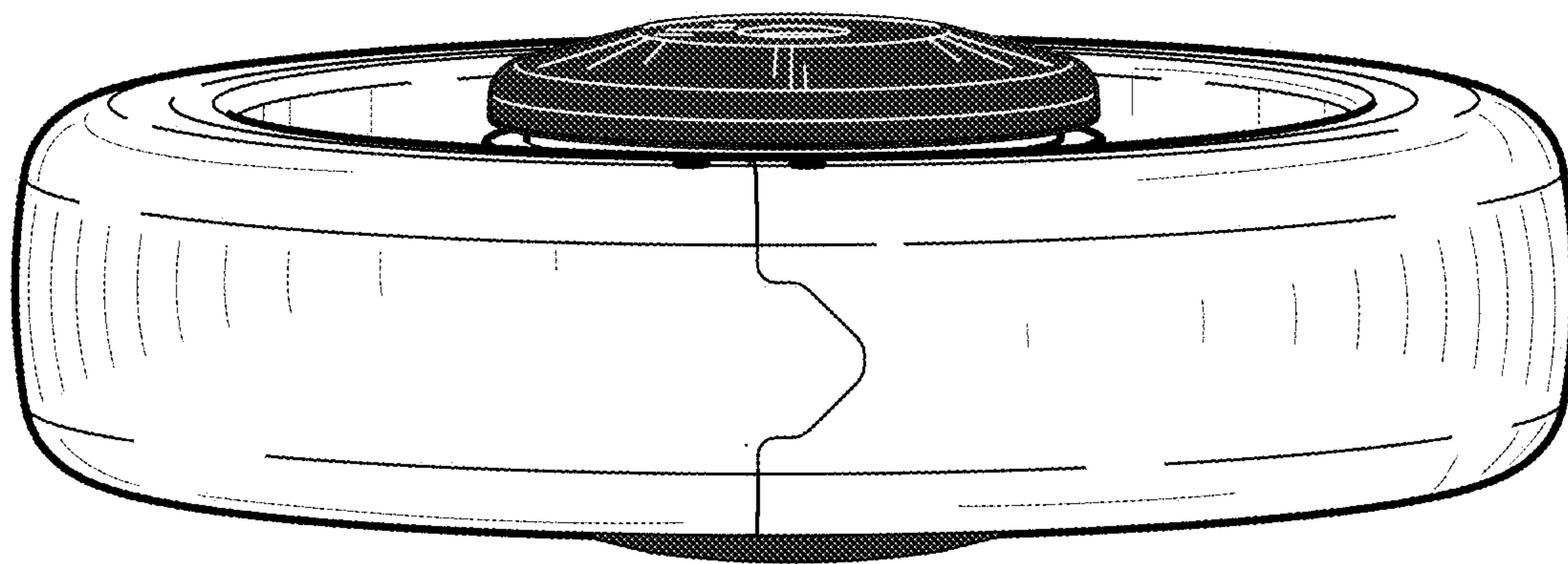

FIG. 27

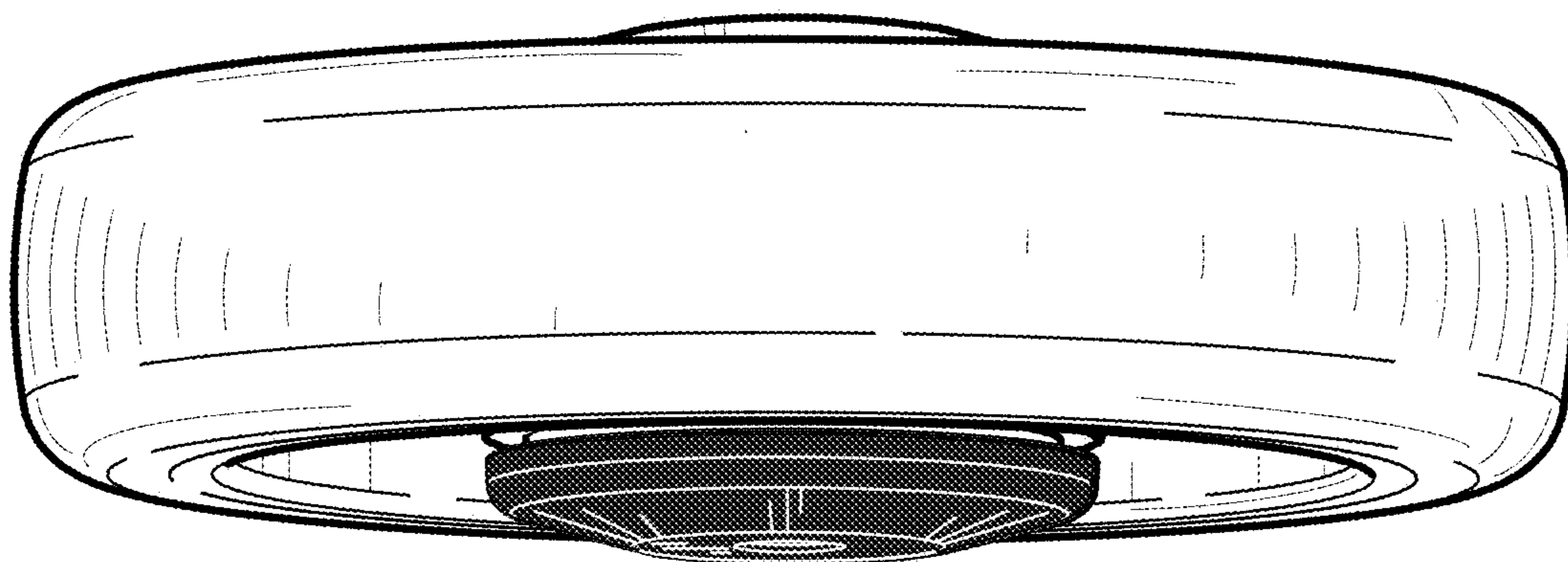

FIG. 28

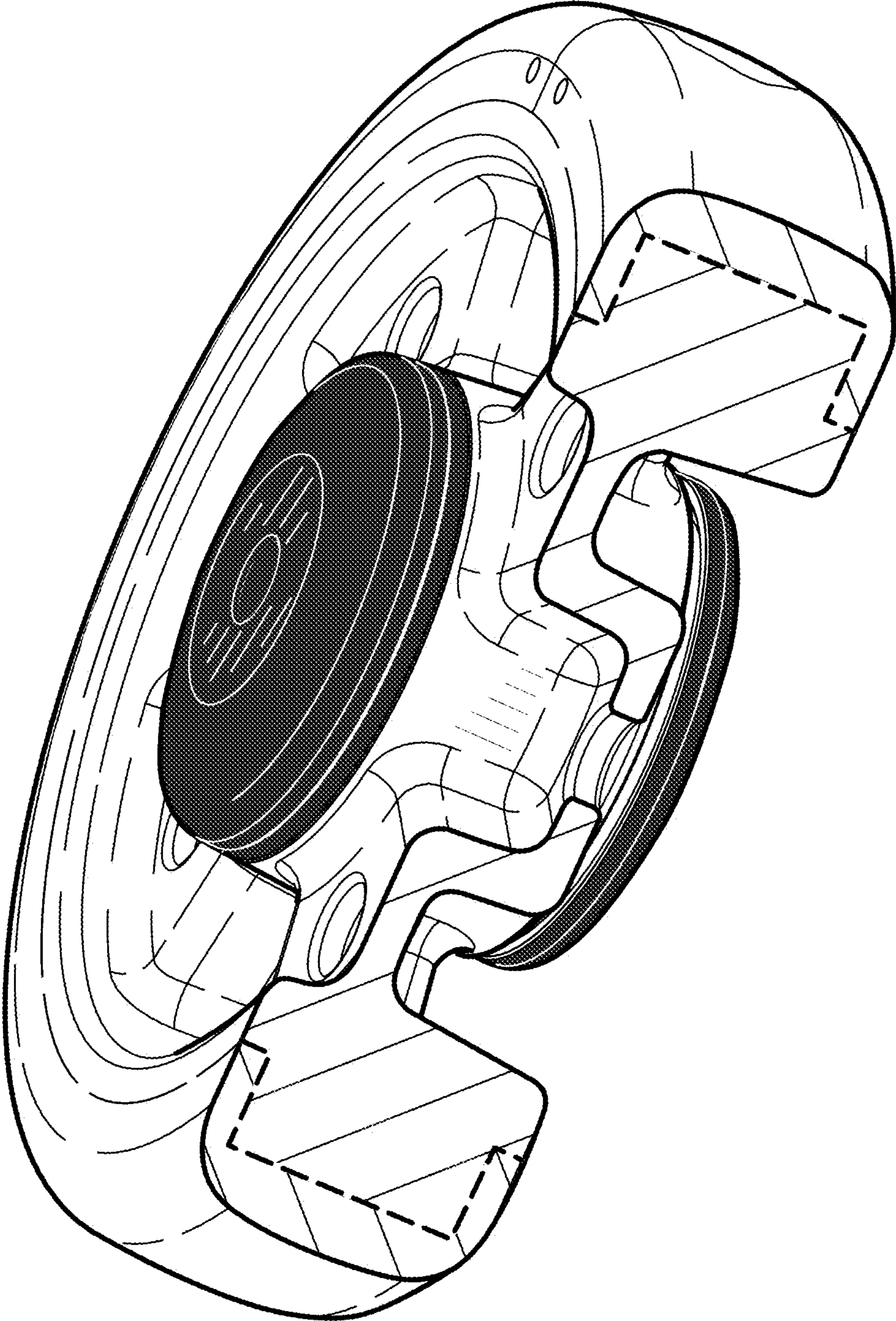

FIG. 29

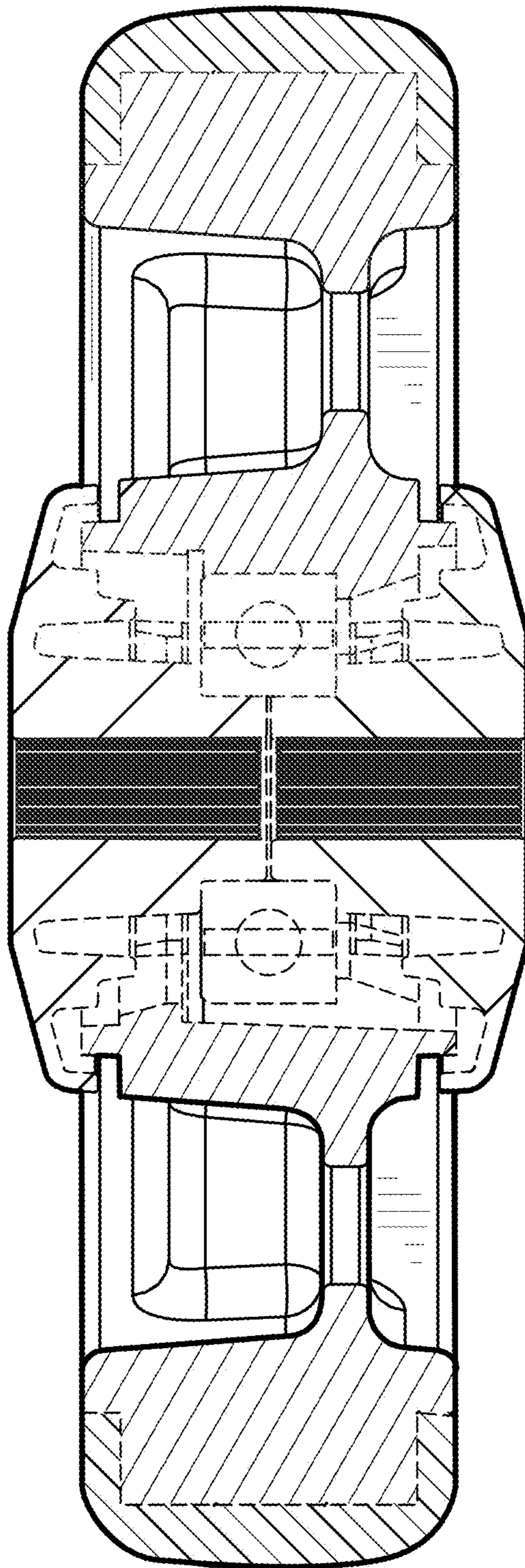

FIG. 30