



US00D916985S

(12) **United States Design Patent**
Wu et al.

(10) **Patent No.:** **US D916,985 S**
(45) **Date of Patent:** **** Apr. 20, 2021**

(54) **SCOOTER**

(71) Applicant: **Golabs Inc.**, Carrollton, TX (US)

(72) Inventors: **Jianbing Wu**, Lishui (CN); **Wei Xu**,
Lishui (CN); **Matao Cao**, Lishui (CN)

(73) Assignee: **GOLABS INC.**, Carrollton, TX (US)

(**) Term: **15 Years**

(21) Appl. No.: **29/711,114**

(22) Filed: **Oct. 29, 2019**

(30) **Foreign Application Priority Data**

Jun. 22, 2019 (CN) 201930326494.6

(51) **LOC (13) Cl.** **21-01**

(52) **U.S. Cl.**
USPC **D21/423**

(58) **Field of Classification Search**
USPC D12/107-113, 128; D21/419, 423, 765,
D21/771, 107
CPC B62K 3/002; B62K 9/00; B52K 2202/00;
B60Y 2200/126
See application file for complete search history.

(56) **References Cited**

U.S. PATENT DOCUMENTS

D903,002 S * 11/2020 Wang D21/423
D905,793 S * 12/2020 Yang D21/423

D905,794 S * 12/2020 Liu D21/423
D911,454 S * 2/2021 Yang D21/423
D911,457 S * 2/2021 Yu D21/423

* cited by examiner

Primary Examiner — Abraham Bahta

(74) *Attorney, Agent, or Firm* — Locke Lord LLP; Tim
Tingkang Xia, Esq.

(57) **CLAIM**

The ornamental design for a scooter, as shown and
described.

DESCRIPTION

FIG. 1 is a perspective view of a scooter according to my
new design;
FIG. 2 is a front elevation view thereof;
FIG. 3 is a rear elevation view thereof;
FIG. 4 is a right side elevation view thereof;
FIG. 5 is a left side elevation view thereof;
FIG. 6 is a top plan view thereof; and,
FIG. 7 is a bottom plan view thereof.
The broken lines in FIGS. 1-7 illustrating certain portions of
the scooter form no part of the claimed design.

1 Claim, 7 Drawing Sheets

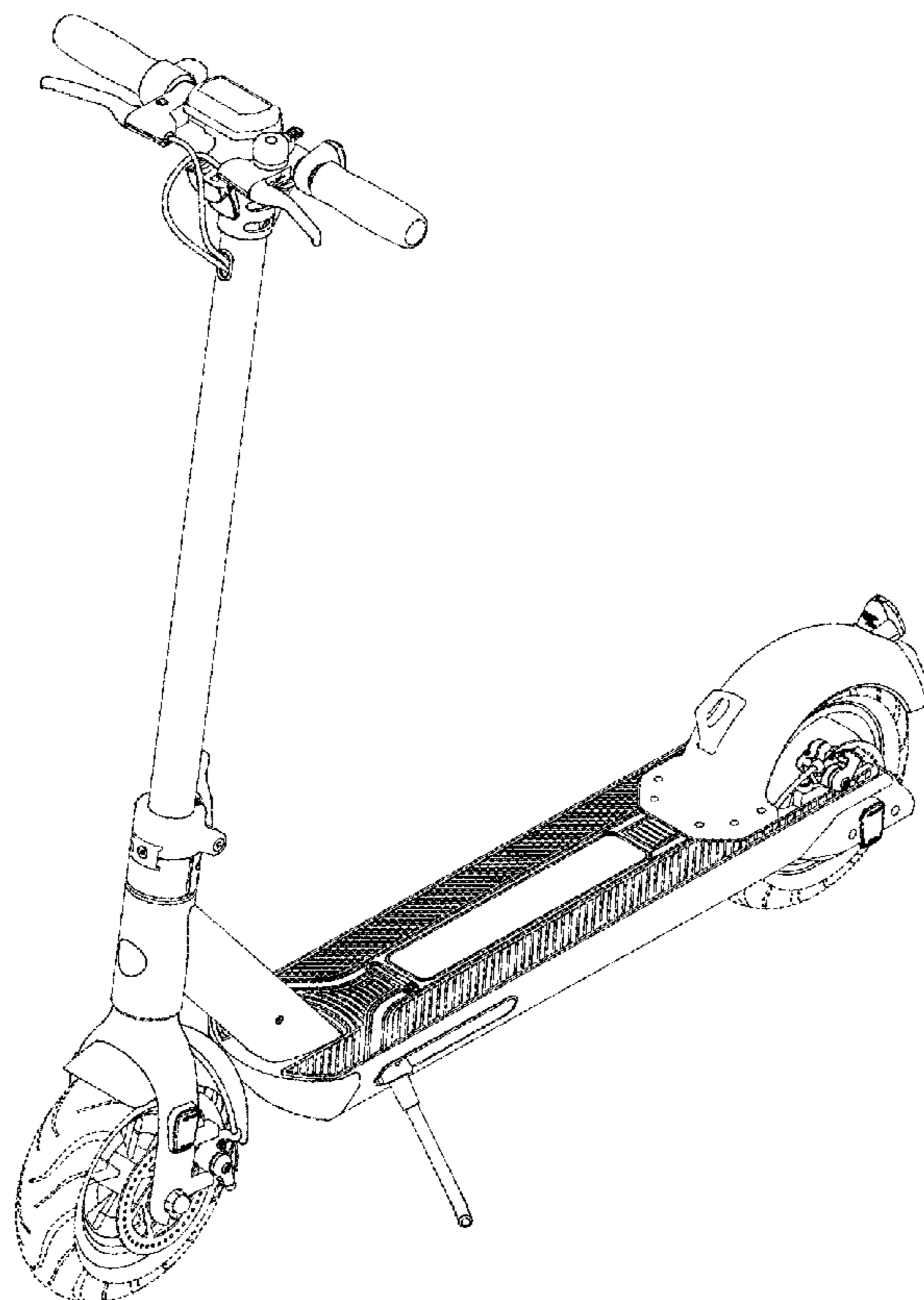

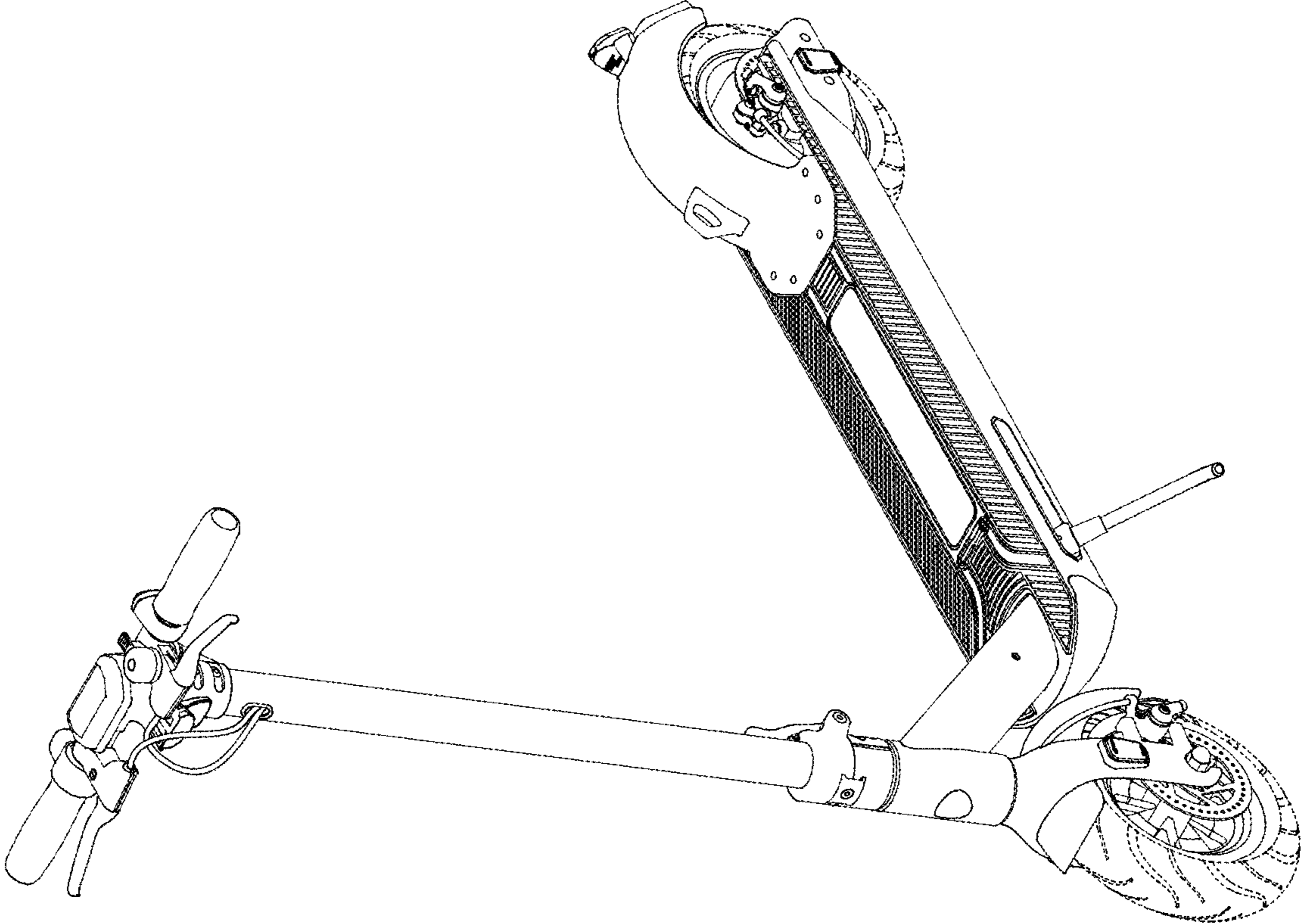

FIG. 1

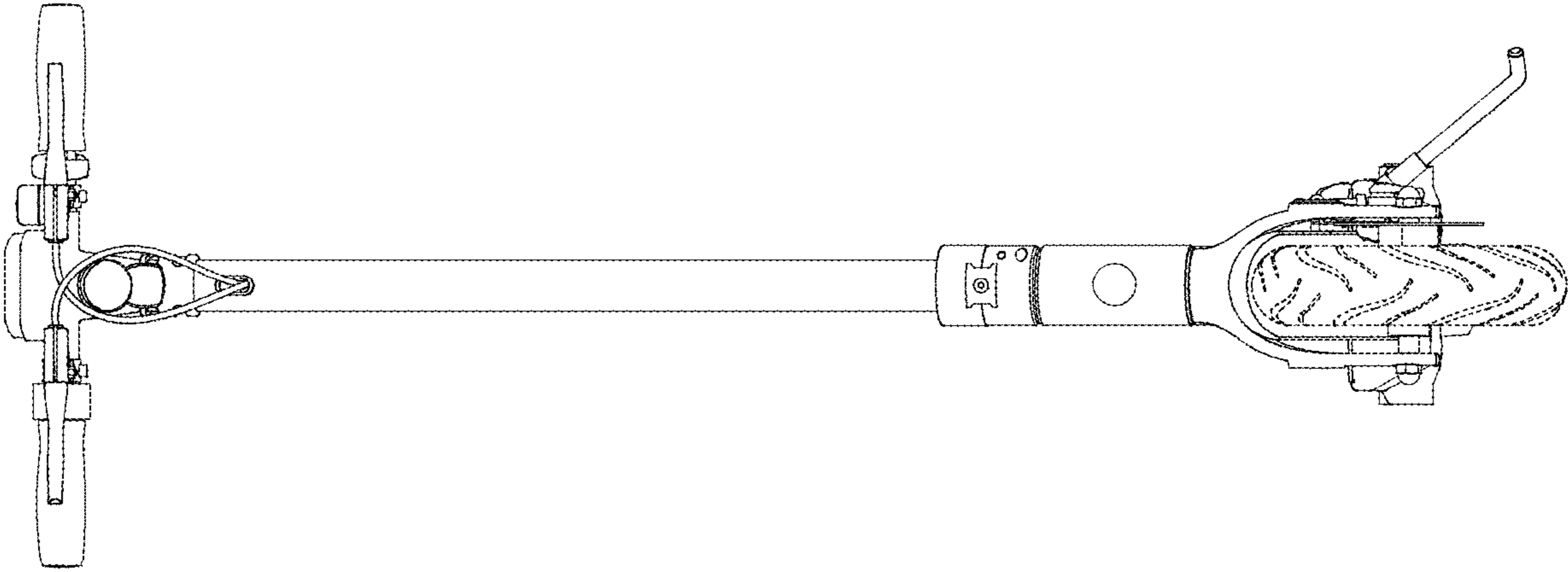

FIG. 2

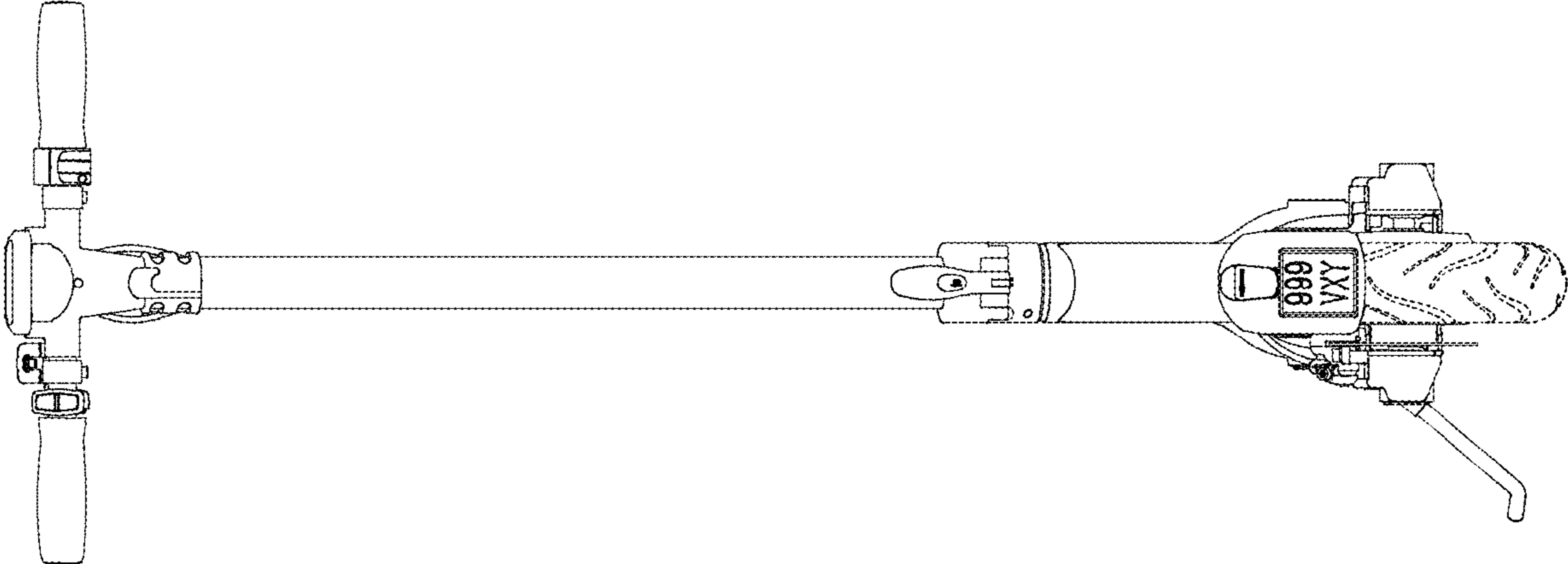

FIG. 3

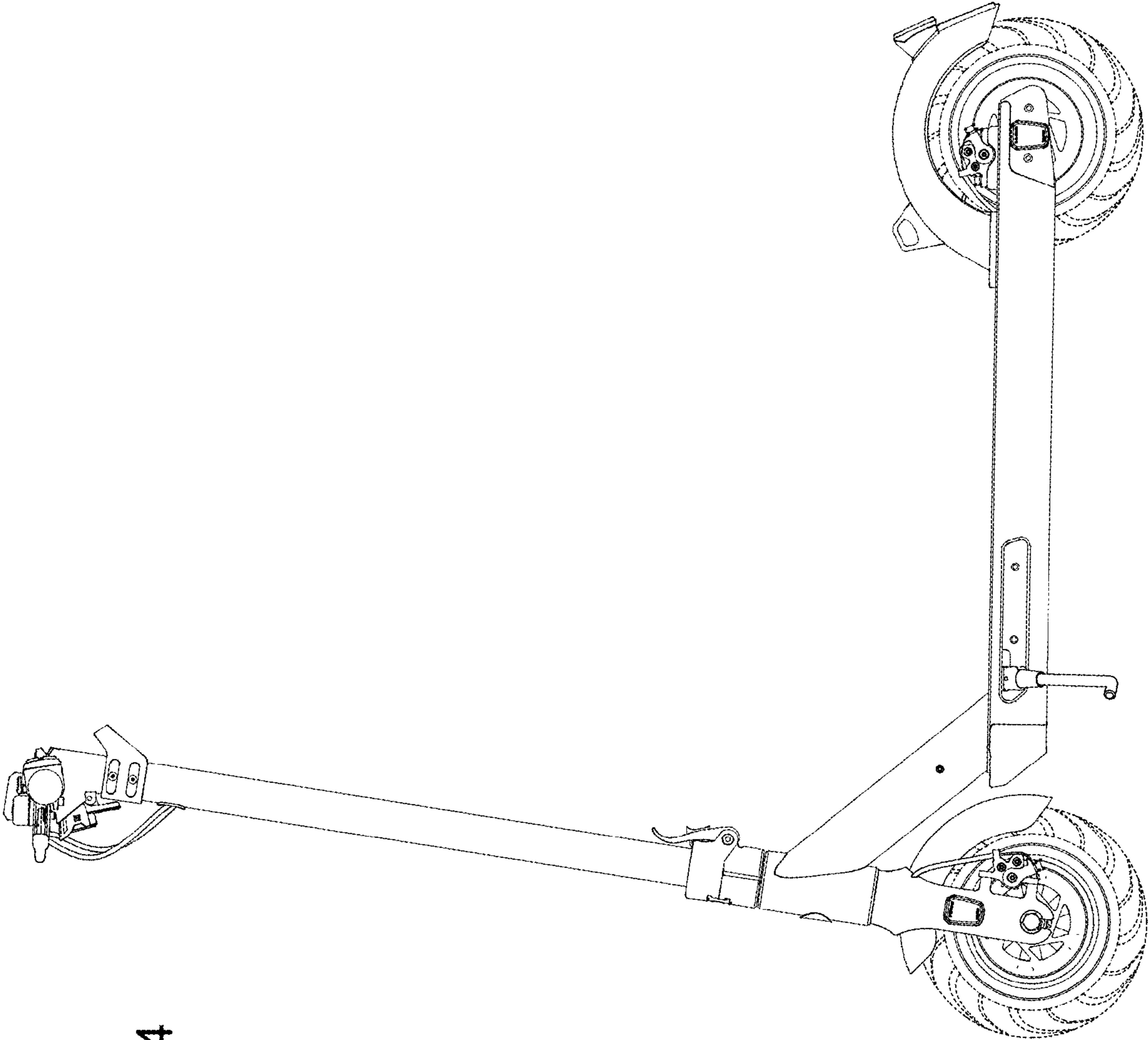

FIG. 4

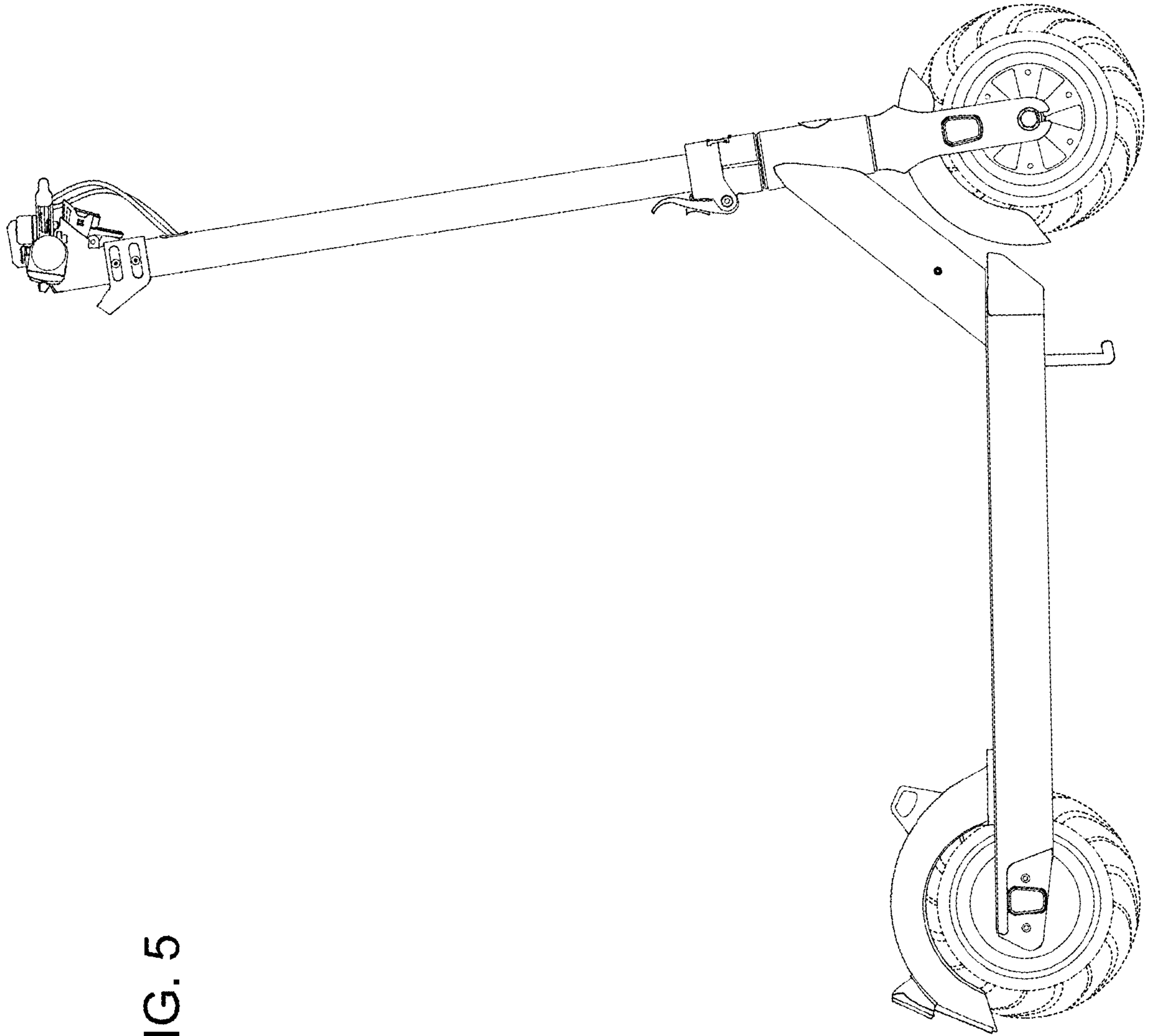

FIG. 5

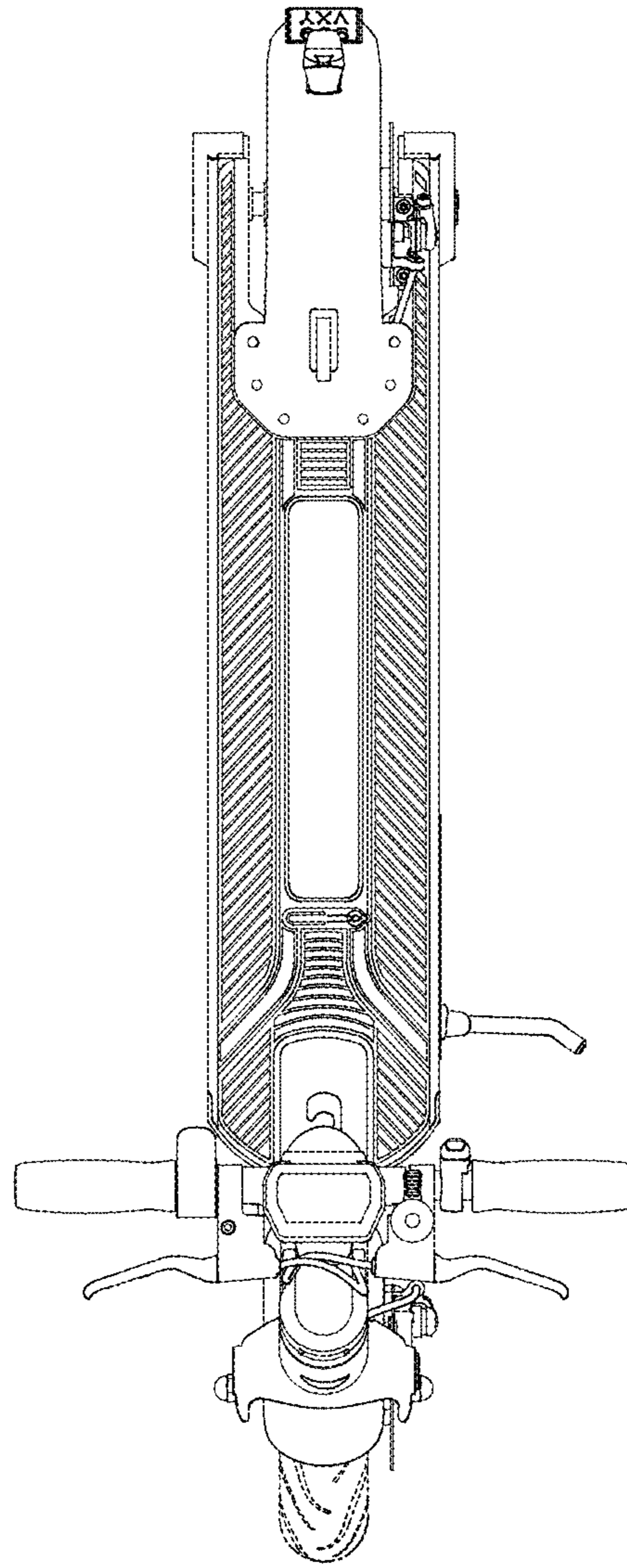

FIG. 6

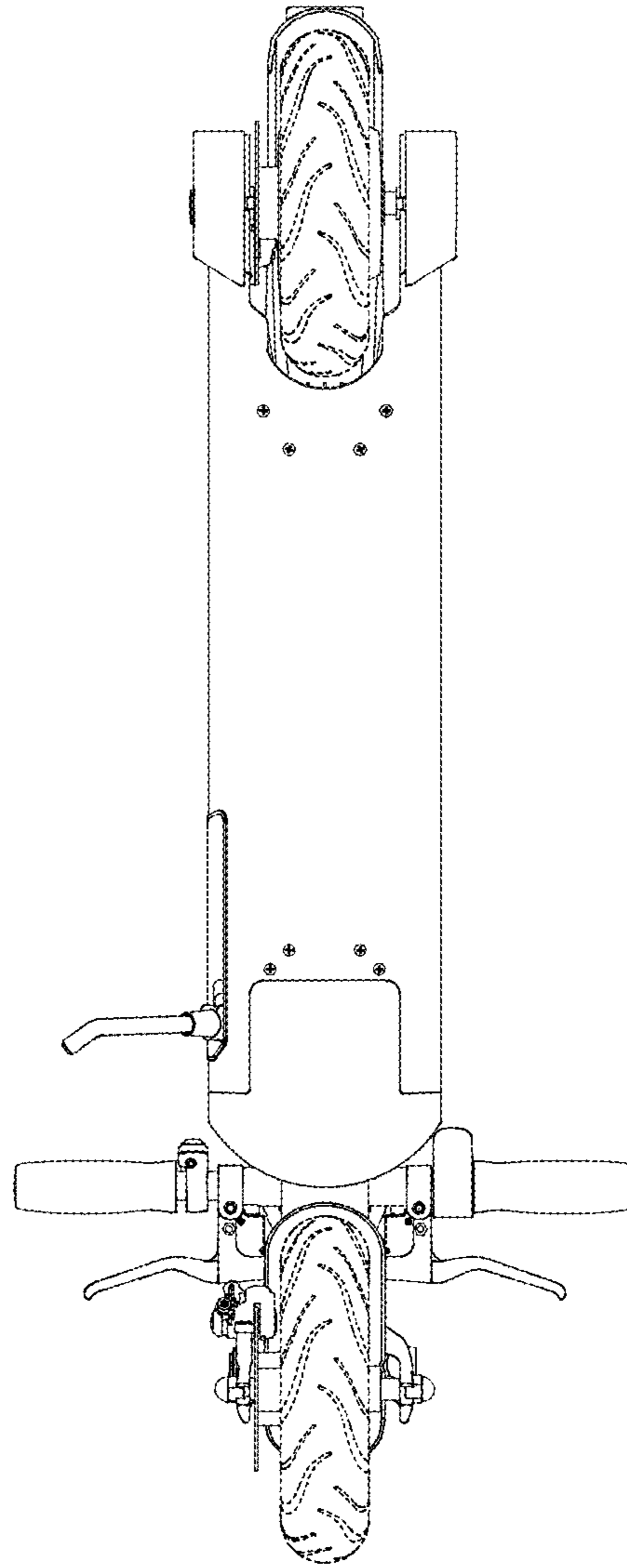

FIG. 7