



US00D916686S

(12) **United States Design Patent** (10) **Patent No.:** **US D916,686 S**  
**Xie** (45) **Date of Patent:** **\*\* Apr. 20, 2021**

(54) **SPEAKER HOLDER**  
(71) Applicant: **Shenzhen Prime Technology Co., Ltd,**  
Shenzhen (CN)  
(72) Inventor: **Menghong Xie,** Shenzhen (CN)  
(\*\*) Term: **15 Years**  
(21) Appl. No.: **29/751,877**  
(22) Filed: **Sep. 23, 2020**  
(51) **LOC (13) Cl.** ..... **14-01**  
(52) **U.S. Cl.**  
USPC ..... **D14/224**  
(58) **Field of Classification Search**  
USPC ... D14/224, 211, 214, 209.1, 204, 371, 253,  
D14/447, 434; D6/681.2; D8/363, 354,  
D8/368, 371; 248/441.1, 442.2, 439, 172,  
248/678, 460, 917; 108/72, 150  
CPC ..... G06F 1/16; A47B 91/00; A47B 97/04;  
F16M 11/00; A47G 1/16  
See application file for complete search history.

(56) **References Cited**

**U.S. PATENT DOCUMENTS**

1,415,782 A \* 5/1922 Brace ..... A47F 5/16  
108/150  
1,542,495 A \* 6/1925 Ebert ..... A47B 21/045  
211/51  
1,651,471 A \* 12/1927 Sawyer ..... G09F 3/20  
248/448  
2,236,133 A \* 3/1941 Croninger ..... B41J 29/15  
248/442.2  
2,577,724 A \* 12/1951 Weller ..... A47B 1/05  
108/72  
2,875,805 A \* 3/1959 Flora ..... B60Q 1/045  
411/111  
3,467,033 A \* 9/1969 Remer ..... A47C 9/10  
108/150  
D219,033 S \* 10/1970 Salsgiver ..... D6/656.11

3,934,806 A \* 1/1976 Rady ..... A47B 19/06  
248/441.1  
4,078,757 A \* 3/1978 Waters ..... A47B 19/02  
108/150  
D262,535 S \* 1/1982 Fisher ..... D14/229  
D267,513 S \* 1/1983 Weigel ..... 5/81.1 R  
4,607,818 A \* 8/1986 Georgopoulos ..... E06B 9/323  
160/902  
5,020,768 A \* 6/1991 Hardt ..... F16M 11/22  
248/188  
D326,969 S \* 6/1992 Eason ..... D14/224  
D328,898 S \* 8/1992 Christie ..... D14/211  
D330,021 S \* 10/1992 Kline ..... D14/447  
D338,882 S \* 8/1993 Reiter ..... D14/447  
5,362,019 A \* 11/1994 Swanson ..... A47G 29/1216  
232/39  
D360,887 S \* 8/1995 Karnaze ..... D14/224

(Continued)

**FOREIGN PATENT DOCUMENTS**

EM 002411512-0001 \* 2/2014

*Primary Examiner* — Paula Allen Greene  
(74) *Attorney, Agent, or Firm* — W&K IP

(57) **CLAIM**

The ornamental design for a speaker holder, as shown and described.

**DESCRIPTION**

FIG. 1 is a perspective view of a speaker holder showing my new design;  
FIG. 2 is a front view thereof;  
FIG. 3 is a rear view thereof;  
FIG. 4 is a left side view thereof;  
FIG. 5 is a right side view thereof;  
FIG. 6 is a top plan view thereof; and,  
FIG. 7 is a bottom plan view thereof.  
The evenly-broken lines where present illustrate portions of the speaker holder that form no part of the claimed design.

**1 Claim, 7 Drawing Sheets**

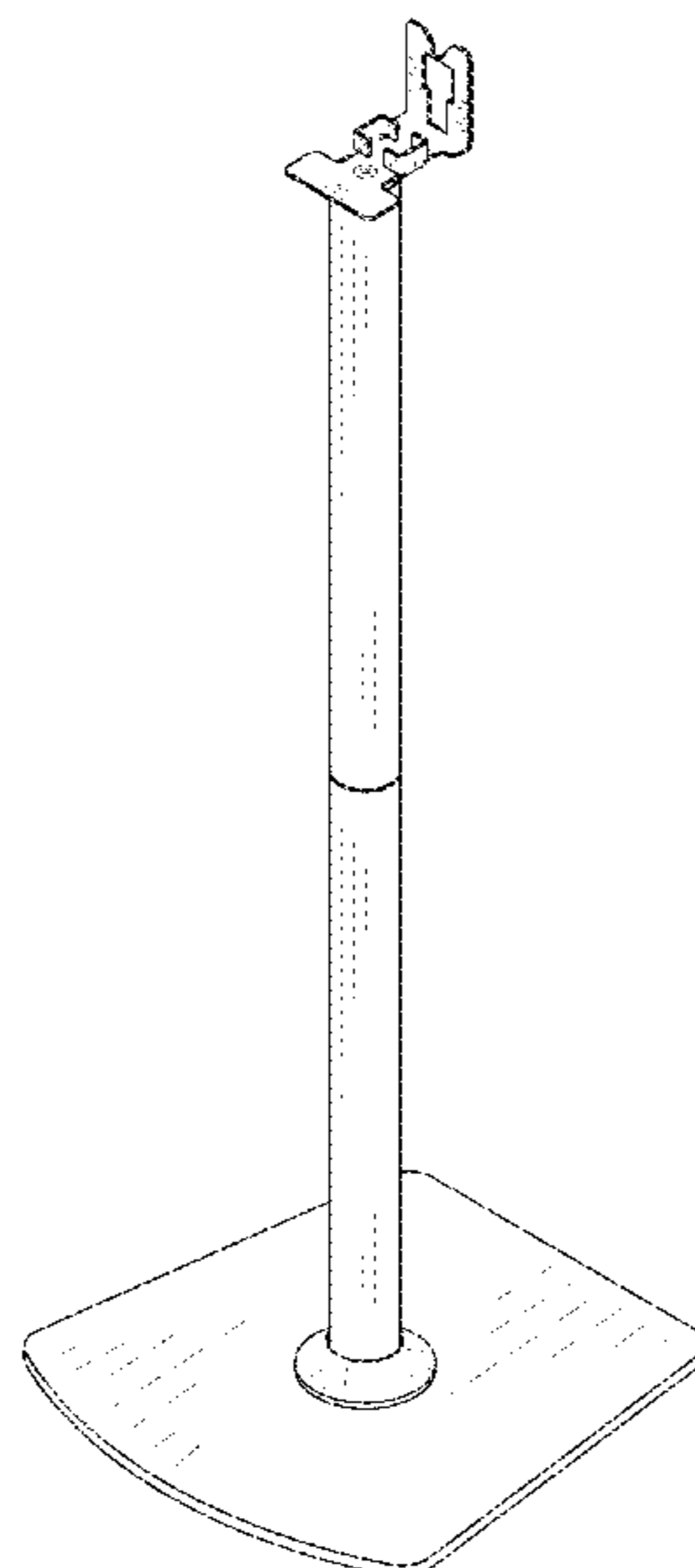

(56)

References Cited

U.S. PATENT DOCUMENTS

D400,735 S \* 11/1998 House ..... D14/448  
 D412,331 S \* 7/1999 Nakamura ..... D14/155  
 D415,494 S \* 10/1999 Curina ..... D14/211  
 D417,872 S \* 12/1999 Monson ..... D14/211  
 D423,821 S \* 5/2000 Crump ..... D14/299  
 D426,540 S \* 6/2000 Tejima ..... D14/224  
 D454,263 S \* 3/2002 Worrall ..... D14/224  
 D483,026 S \* 12/2003 Koskinen ..... D14/211  
 D488,803 S \* 4/2004 Chin ..... D14/211  
 D497,904 S \* 11/2004 Dardashti ..... D14/224  
 6,833,988 B2 \* 12/2004 Kamphuis ..... G06F 1/1601  
 248/424  
 D508,480 S \* 8/2005 Oikawa ..... D14/211  
 D515,555 S \* 2/2006 Liang ..... D14/211  
 D522,492 S \* 6/2006 Carbone ..... D14/211  
 D536,683 S \* 2/2007 Lim ..... D14/506  
 D539,269 S \* 3/2007 Yoon ..... D14/211  
 D543,534 S \* 5/2007 Tsuge ..... D14/211  
 D548,724 S \* 8/2007 Hakoda ..... D14/211  
 7,319,767 B2 \* 1/2008 Fidlin ..... H04R 1/06  
 381/182  
 D578,103 S \* 10/2008 Matsuoka ..... D14/211  
 D579,926 S \* 11/2008 Whitworth ..... D14/224  
 D579,927 S \* 11/2008 Whitworth ..... D14/224  
 D581,697 S \* 12/2008 Fix ..... D6/681.2  
 D581,698 S \* 12/2008 Fix ..... D14/224  
 D585,875 S \* 2/2009 Matsuoka ..... D14/211

D598,217 S \* 8/2009 Bode ..... D6/681.2  
 7,789,363 B2 \* 9/2010 Duan ..... F16M 11/24  
 248/284.1  
 D648,475 S \* 11/2011 Heyrman ..... D26/107  
 D649,552 S 11/2011 Huang  
 8,727,295 B2 \* 5/2014 Peng ..... F16M 13/00  
 248/346.06  
 D716,764 S \* 11/2014 Jeon ..... D14/209.1  
 D721,074 S \* 1/2015 Harris ..... D14/253  
 D723,311 S \* 3/2015 Jiang ..... D6/681  
 9,022,341 B2 \* 5/2015 Radmard ..... F16M 13/00  
 248/558  
 D739,410 S \* 9/2015 Chun ..... D14/447  
 D740,253 S \* 10/2015 Jeon ..... D14/204  
 D743,371 S \* 11/2015 Nardin ..... D14/209.1  
 D743,378 S \* 11/2015 Kim ..... D14/216  
 D772,217 S \* 11/2016 Alesi ..... D14/253  
 9,578,979 B1 \* 2/2017 Zeuch ..... G09F 3/12  
 D783,000 S \* 4/2017 Koo ..... D14/209.1  
 D793,996 S \* 8/2017 Katz ..... D14/224  
 D827,405 S \* 9/2018 Chun ..... D8/72  
 D847,119 S \* 4/2019 Theisen ..... D14/209.1  
 D854,006 S \* 7/2019 Wang ..... D14/253  
 D855,038 S \* 7/2019 Hu ..... D14/224  
 D907,470 S \* 1/2021 Ruddick ..... D8/356  
 2004/0041068 A1 \* 3/2004 Gelfand ..... A47B 97/04  
 248/460  
 2012/0074271 A1 \* 3/2012 Goetz ..... F16M 13/00  
 248/121

\* cited by examiner

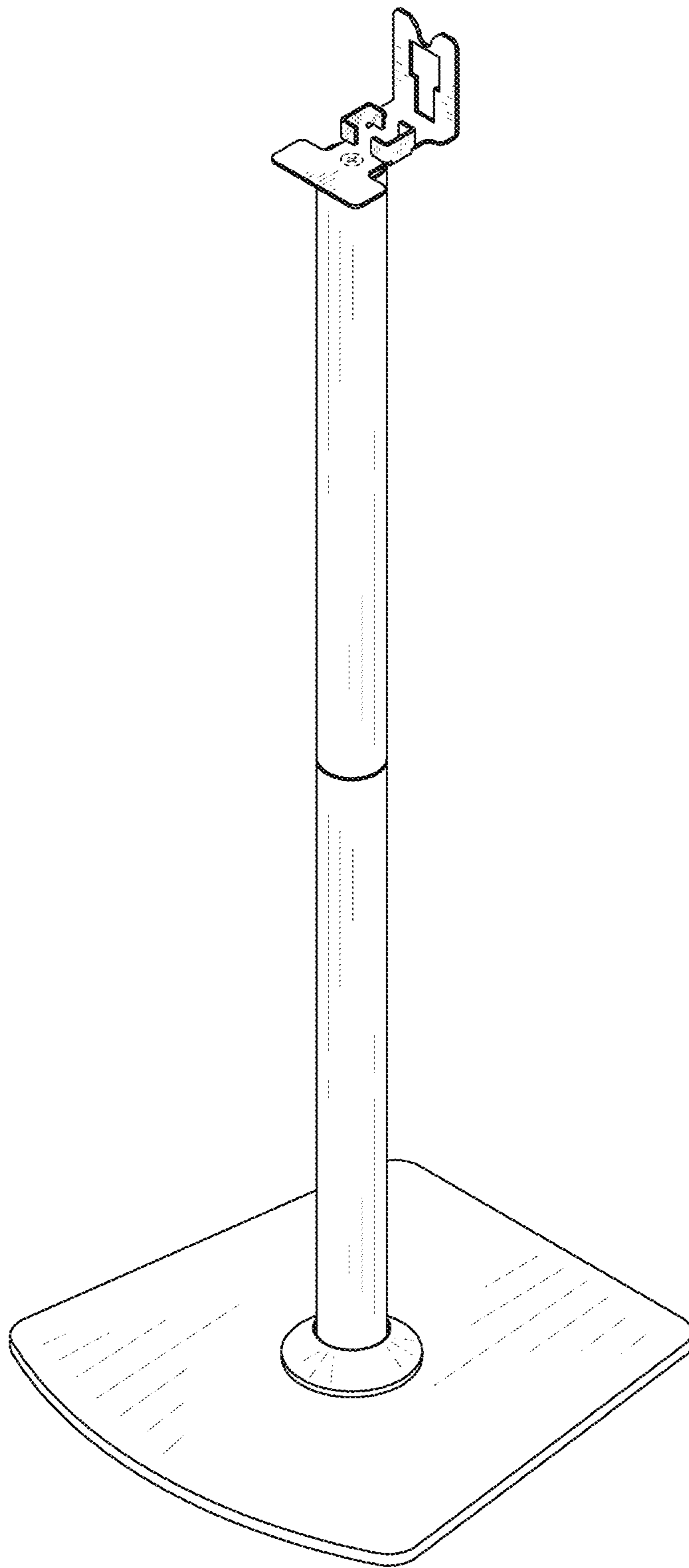

FIG.1

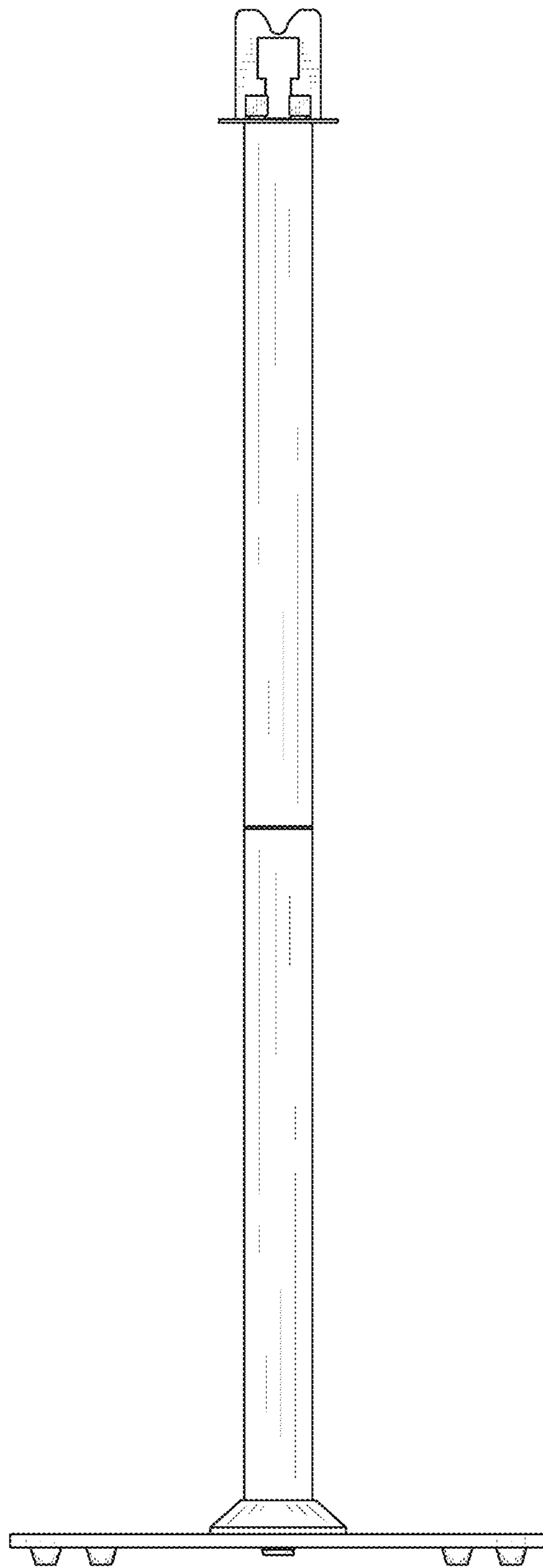

FIG. 2

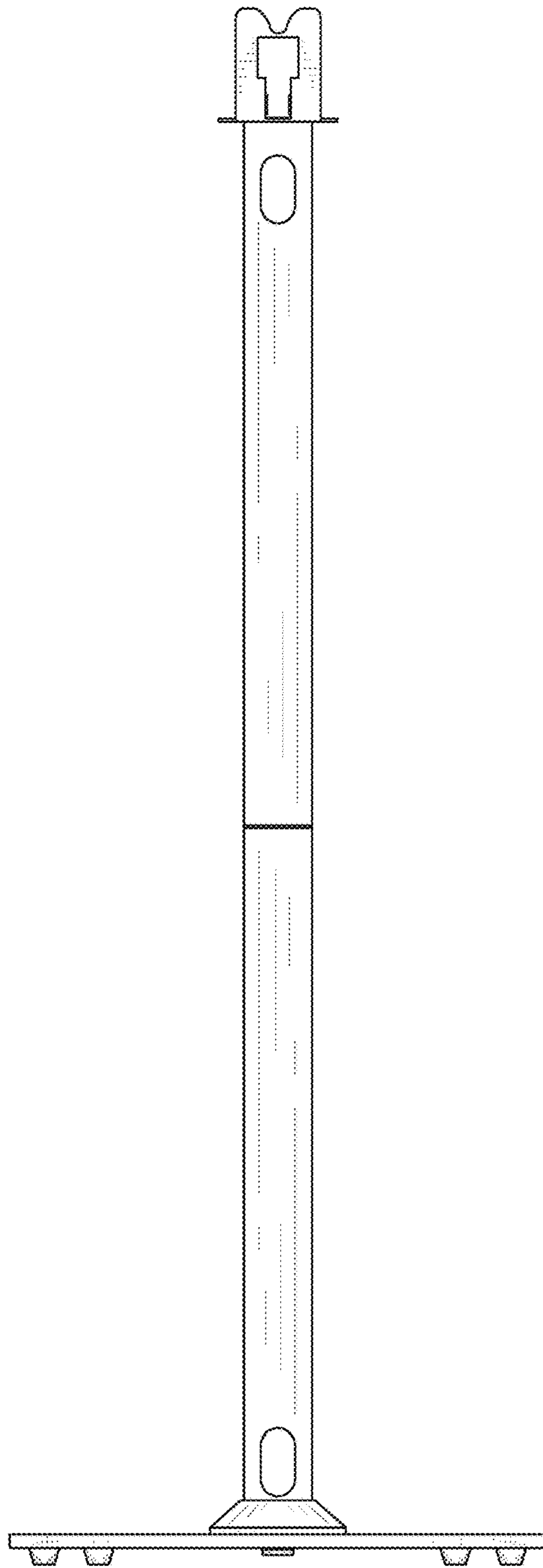

FIG. 3

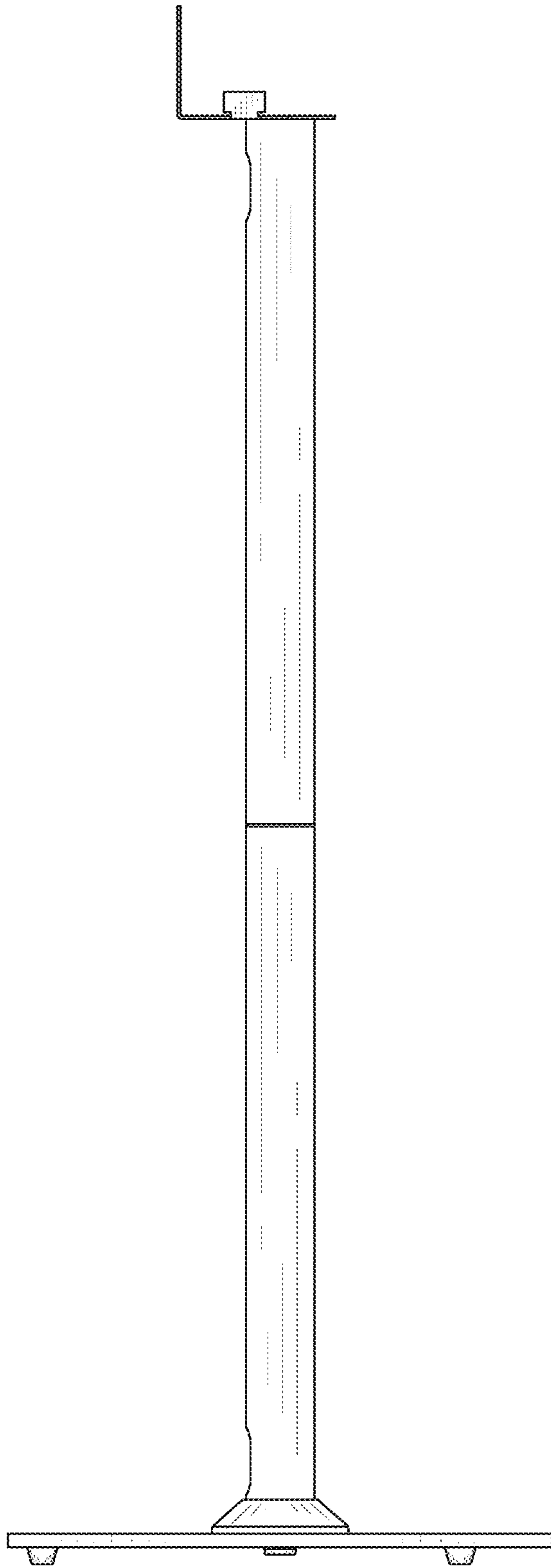

FIG. 4

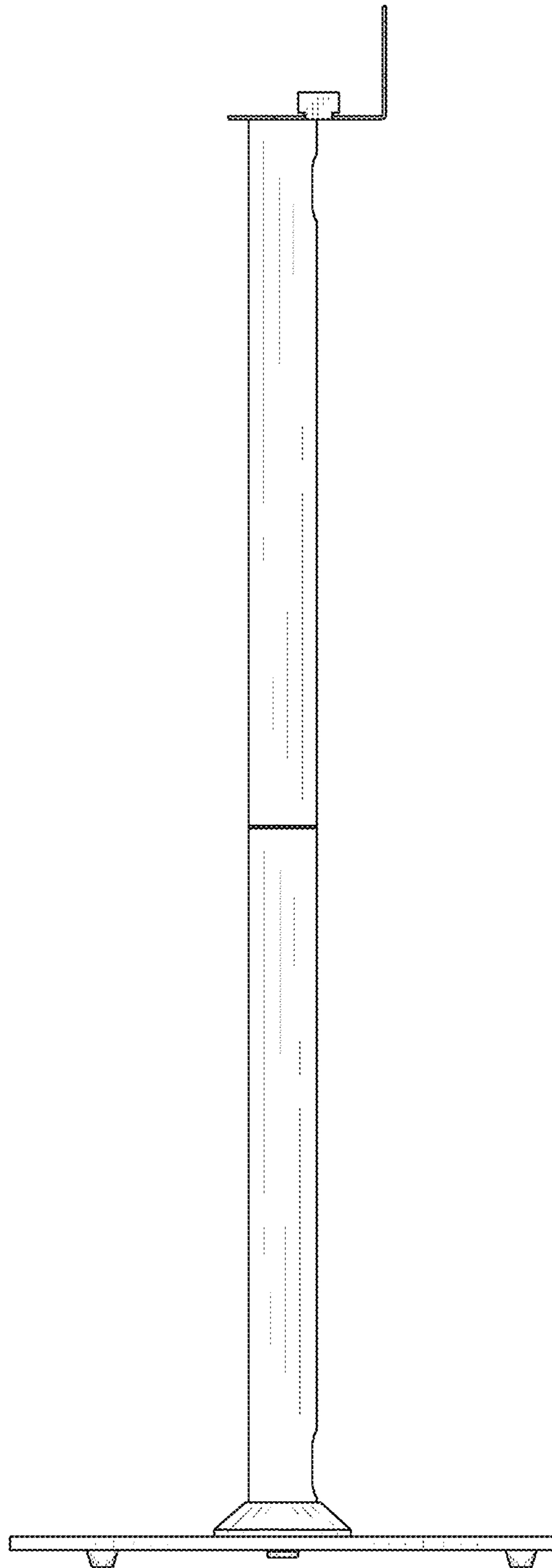

FIG. 5

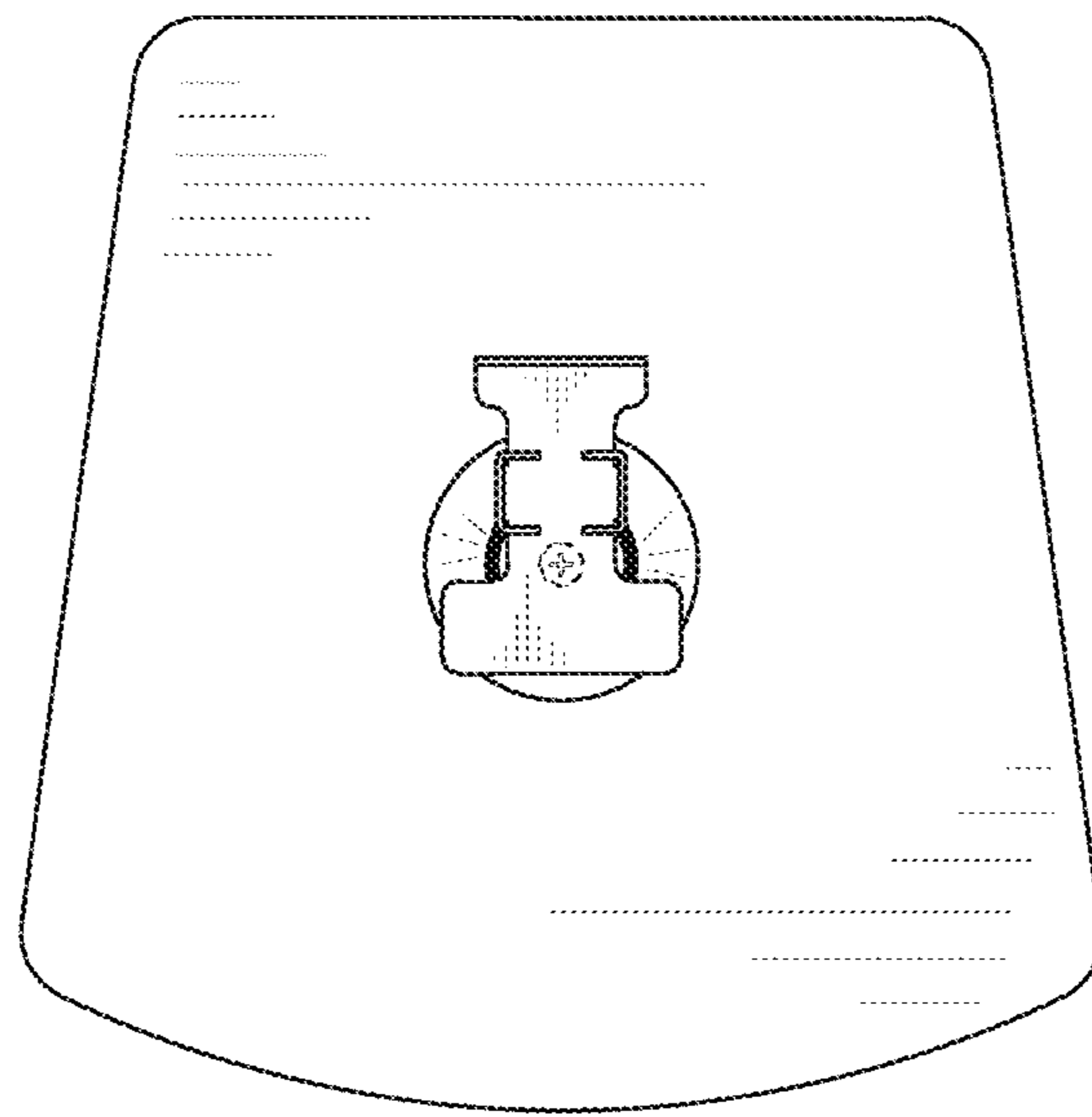

FIG. 6



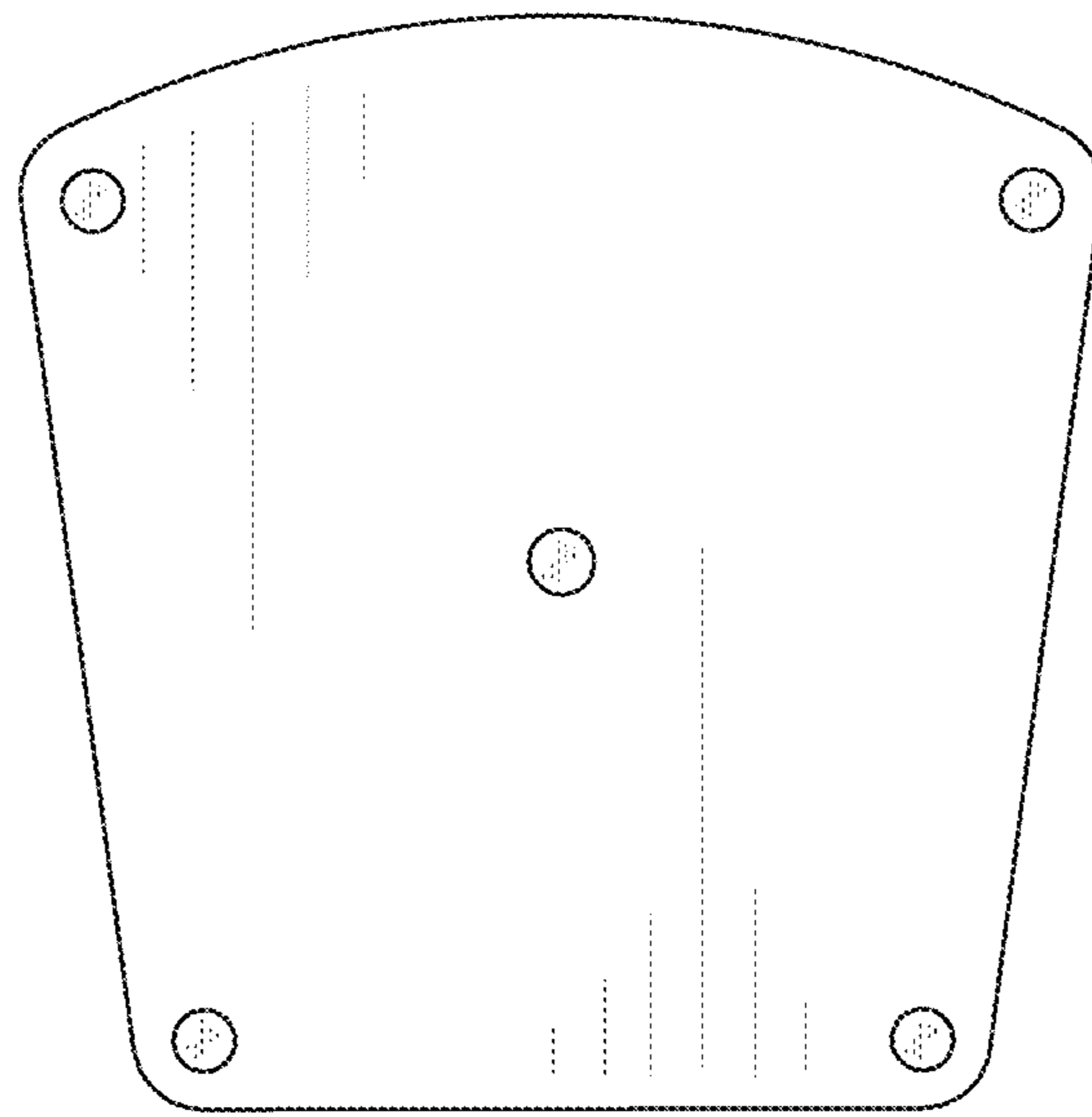

FIG. 7