



US00D916364S

(12) **United States Design Patent** (10) **Patent No.:** **US D916,364 S**  
**Li** (45) **Date of Patent:** **\*\* Apr. 13, 2021**

(54) **WATER PIPE**  
(71) Applicant: **Zilong Li, Jiangxi (CN)**  
(72) Inventor: **Zilong Li, Jiangxi (CN)**  
(\*\*) Term: **15 Years**  
(21) Appl. No.: **29/751,432**  
(22) Filed: **Sep. 21, 2020**  
(51) **LOC (13) Cl.** ..... **27-02**  
(52) **U.S. Cl.**  
USPC ..... **D27/162**  
(58) **Field of Classification Search**  
USPC ..... D27/100, 101, 162-170, 194; D24/110;  
D23/366  
CPC ..... A24F 1/30; A24F 47/008; A61M 15/06  
See application file for complete search history.

D539,978 S \* 4/2007 Kassir ..... D27/162  
D554,797 S \* 11/2007 Kassir ..... D27/162  
D558,919 S \* 1/2008 Kassir ..... D27/162  
D561,388 S \* 2/2008 Kassir ..... D27/162  
D584,853 S \* 1/2009 Kassir ..... D27/162  
7,861,900 B2 \* 1/2011 Ryan ..... B65D 25/24  
222/482  
D632,425 S \* 2/2011 Badawi ..... D27/162  
D634,064 S \* 3/2011 Sweitzer ..... D27/162  
D638,984 S \* 5/2011 Gould ..... D27/163  
D642,733 S \* 8/2011 Sweitzer ..... D27/162  
8,973,585 B2 \* 3/2015 Goldstein ..... B01D 47/021  
131/173  
D728,854 S \* 5/2015 Siniakov ..... D27/162  
D803,375 S \* 11/2017 Wu ..... D23/366  
9,848,639 B1 \* 12/2017 Soares ..... A24F 1/30  
D806,945 S 1/2018 Lepper

(Continued)

*Primary Examiner* — Marissa J Cash  
(74) *Attorney, Agent, or Firm* — ScienBiziP, P.C.

(56) **References Cited**

U.S. PATENT DOCUMENTS

D244,473 S \* 5/1977 Karl ..... D27/162  
D246,391 S \* 11/1977 Lefkow ..... D27/162  
D248,572 S \* 7/1978 Graham ..... D27/162  
D261,690 S \* 11/1981 Murray, Jr. .... D27/163  
D262,144 S \* 12/1981 Sher ..... D27/162  
D273,713 S \* 5/1984 Sher ..... D27/162  
D342,805 S \* 12/1993 Heine ..... D27/162  
D349,780 S \* 8/1994 Heine ..... D27/162  
D351,253 S \* 10/1994 Baig ..... D27/162  
D358,227 S \* 5/1995 Heine ..... D27/162  
D358,228 S \* 5/1995 Heine ..... D27/162  
D368,324 S \* 3/1996 Heine ..... D27/162  
D368,325 S \* 3/1996 Heine ..... D27/162  
D368,551 S \* 4/1996 Richards ..... D27/162  
D381,116 S \* 7/1997 Richards ..... D27/162  
D387,476 S \* 12/1997 Chambers ..... D27/162  
D403,106 S \* 12/1998 Barmes ..... D27/162  
RE36,523 E \* 1/2000 Newman ..... A24F 1/30  
D27/162  
D443,950 S \* 6/2001 Neason ..... D27/162

(57) **CLAIM**

The ornamental design for a water pipe as shown and described.

**DESCRIPTION**

FIG. 1 is a perspective view of a water pipe, showing my design.  
FIG. 2 is a front elevation view thereof.  
FIG. 3 is a rear elevation view thereof.  
FIG. 4 is a right side elevation view thereof.  
FIG. 5 is a left side elevation view thereof.  
FIG. 6 is a top plan view thereof.  
FIG. 7 is a bottom plan view thereof; and,  
FIG. 8 is an enlarged view of an area labeled 8 in FIG. 1.  
The broken lines shown in FIGS. 1 and 8 are for purposes of illustrating the enlarged view and are for annotative purposes only. The broken lines form no part of the claimed design.

**1 Claim, 8 Drawing Sheets**

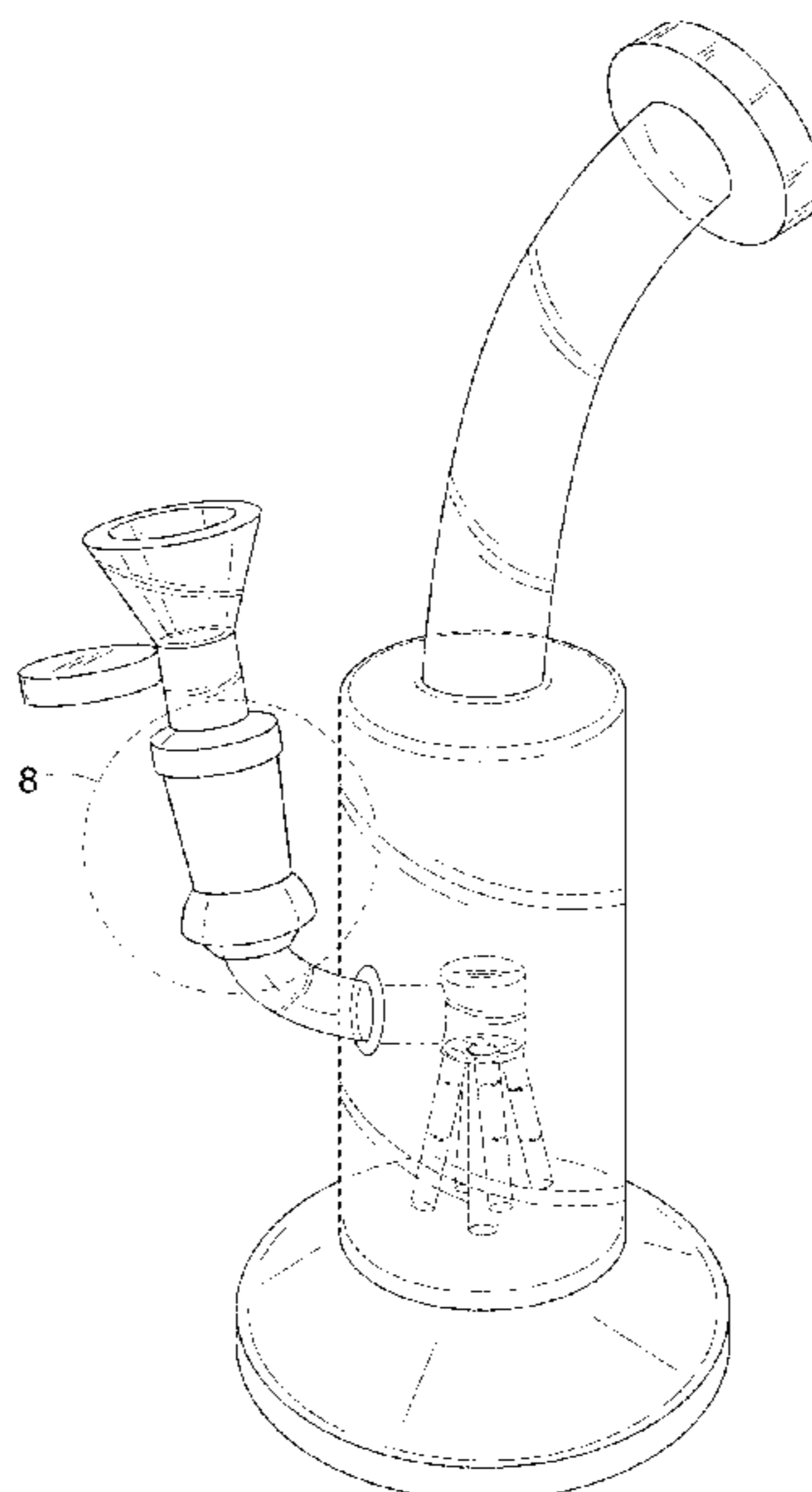

(56)

**References Cited**

U.S. PATENT DOCUMENTS

D820,513	S *	6/2018	Camitta .....	D27/162
10,004,264	B2 *	6/2018	Rado .....	H05B 1/0244
D825,843	S *	8/2018	Hoch .....	D27/163
D838,410	S *	1/2019	Reimann .....	D27/162
D843,647	S *	3/2019	Camitta .....	D27/162
D844,227	S *	3/2019	Hoch .....	D27/162
D854,740	S *	7/2019	Opp .....	D27/162
D863,671	S *	10/2019	Reimann .....	D27/162
10,477,889	B2 *	11/2019	Goldstein .....	A24F 1/32
D874,717	S *	2/2020	Nhep .....	D27/162
D877,974	S *	3/2020	Tucci	
D883,462	S *	5/2020	Wei .....	D23/366
D893,697	S *	8/2020	Xiao .....	D23/366
10,743,580	B2 *	8/2020	Kane .....	A24F 47/008
D895,894	S *	9/2020	Bajpai .....	D27/194
10,820,626	B2 *	11/2020	Benjamignan .....	A24F 1/30
2014/0326256	A1 *	11/2014	McKay .....	A24F 1/30
				131/173
2017/0361040	A1 *	12/2017	Trzeciecki .....	A61M 11/042

\* cited by examiner

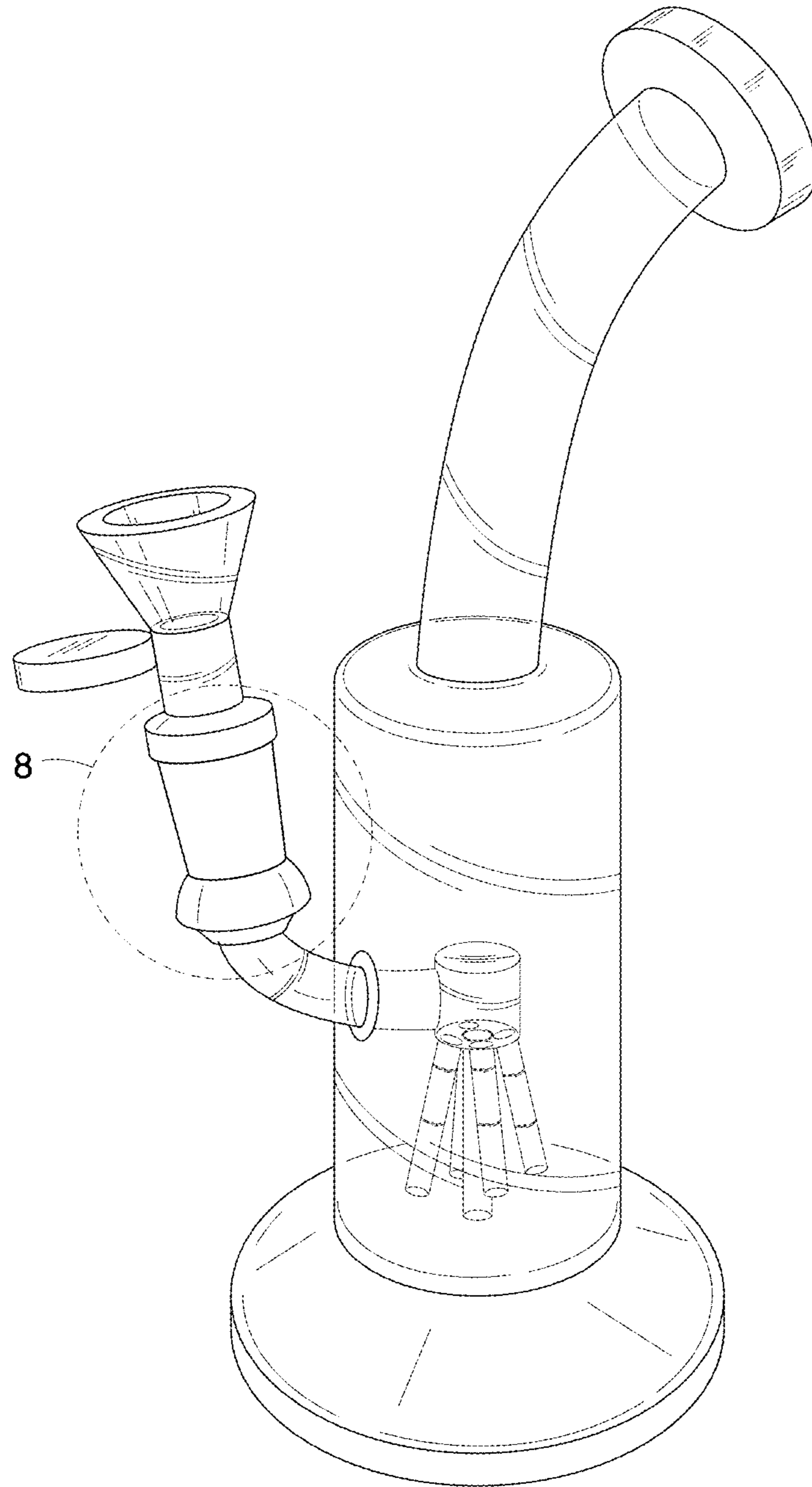

FIG. 1

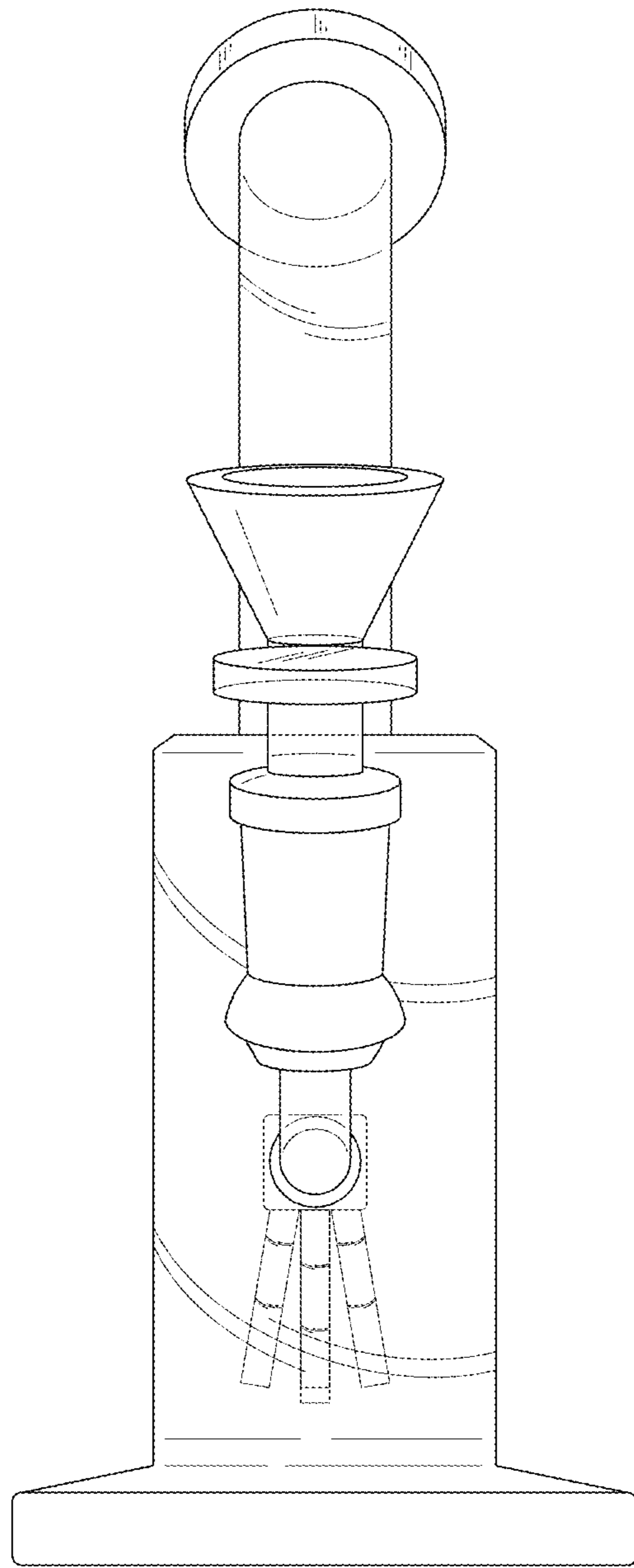

FIG.2

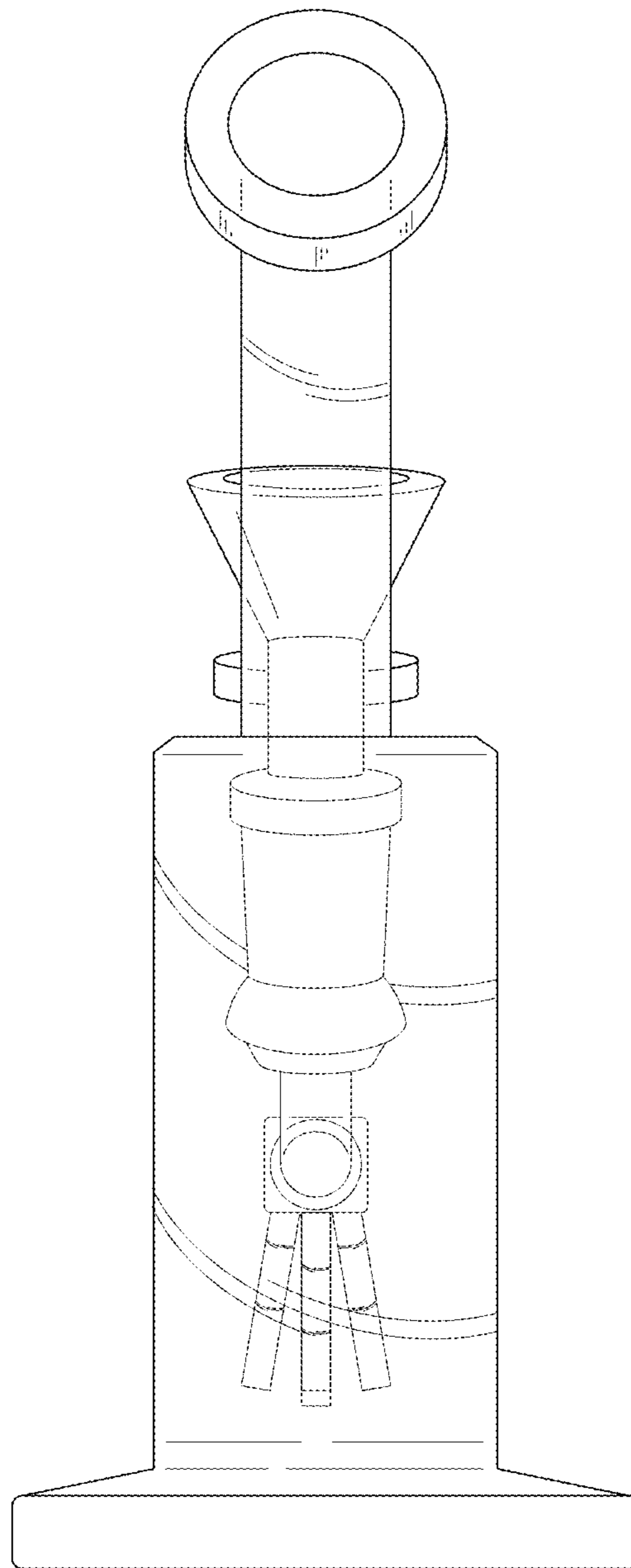

FIG.3

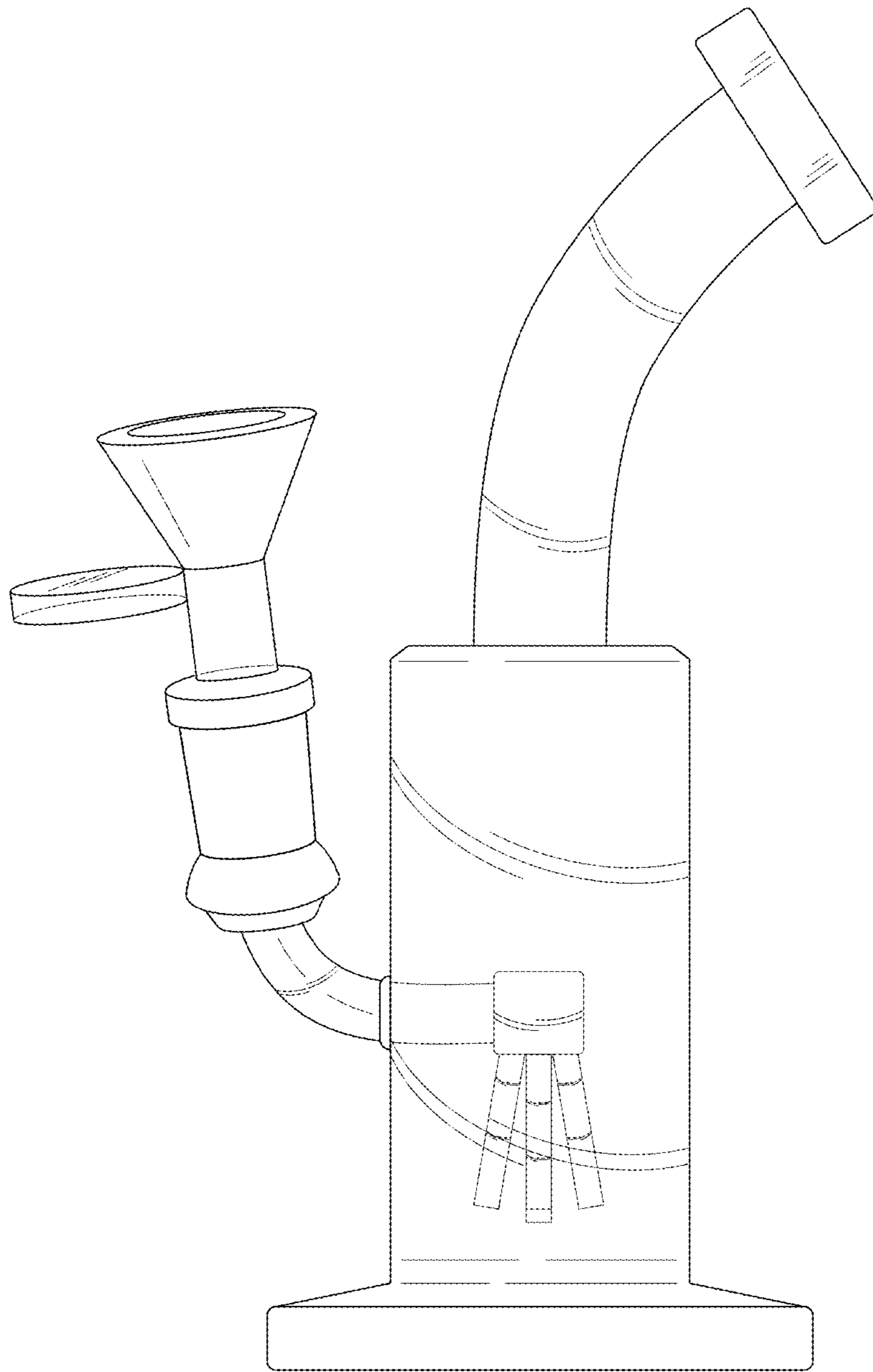

FIG. 4

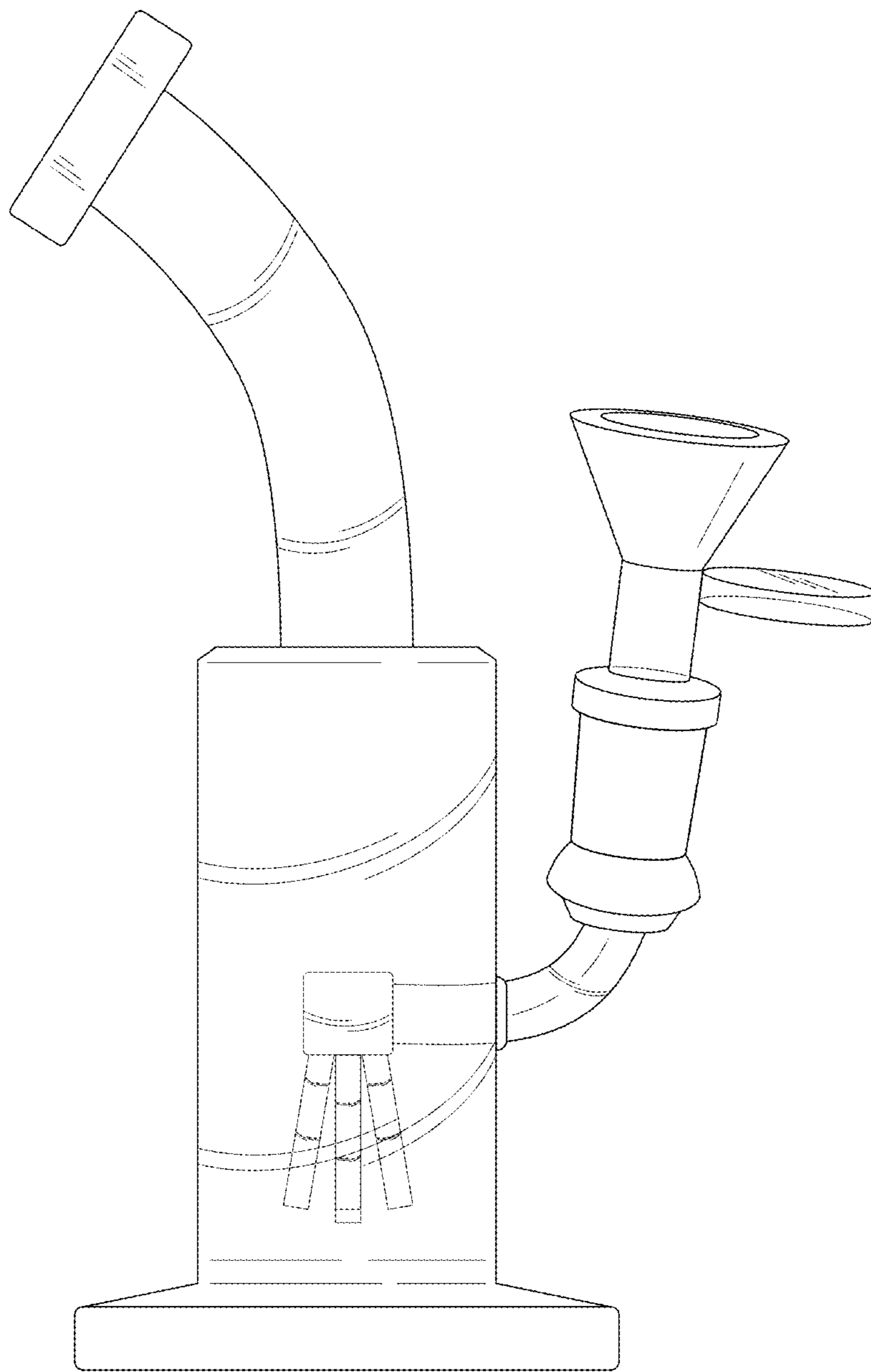

FIG. 5

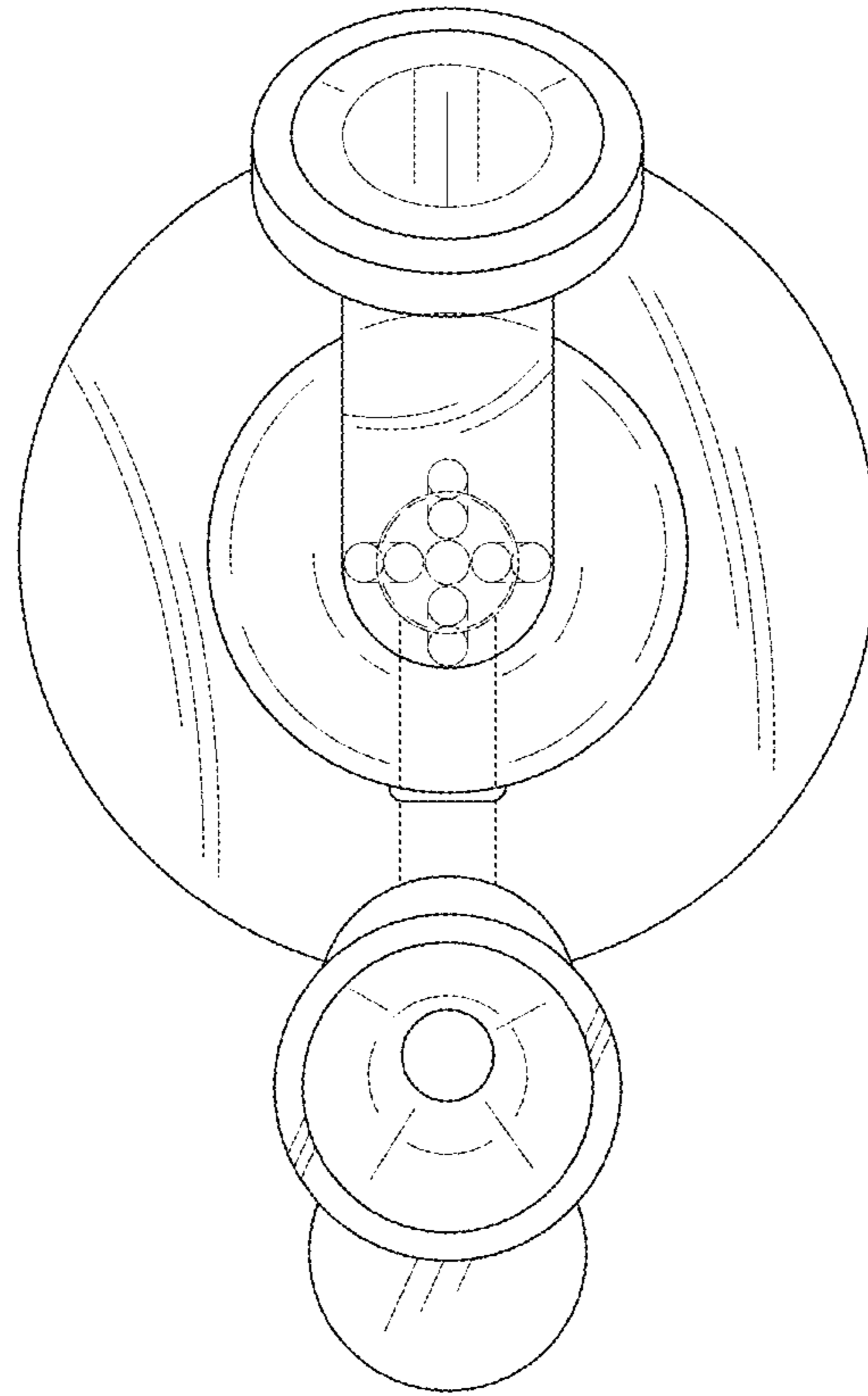

FIG.6



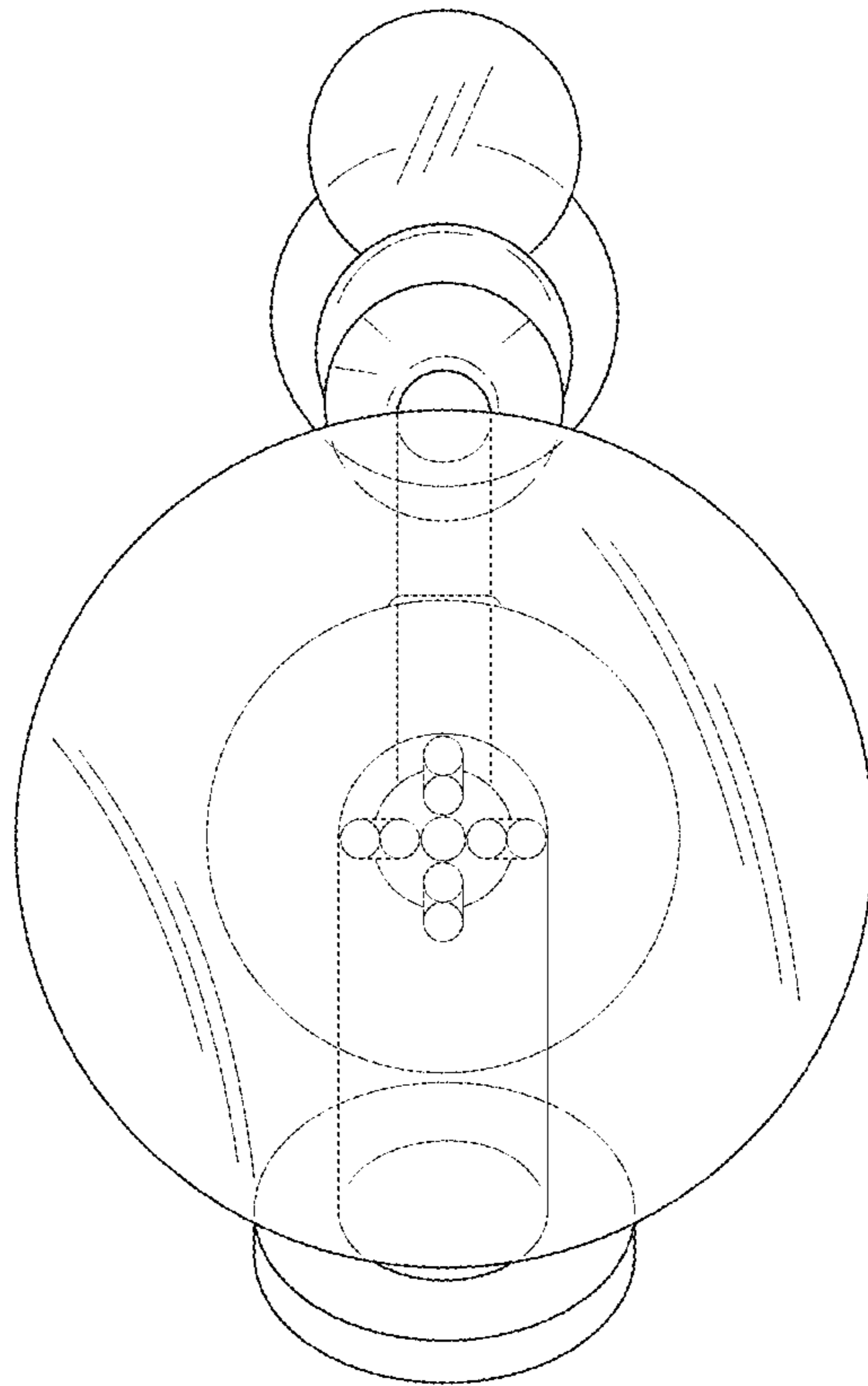

FIG.7

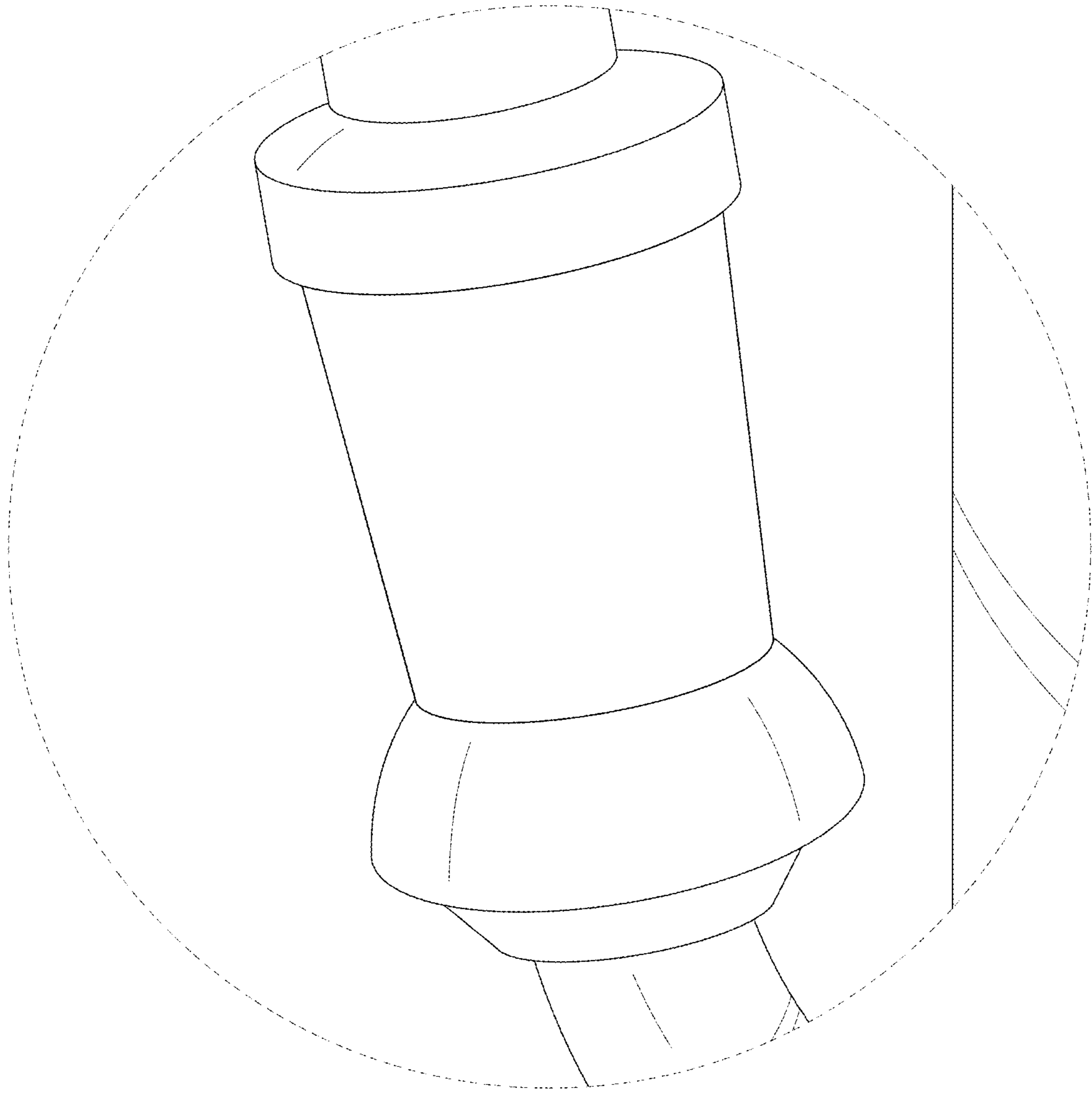

FIG.8