



US00D916294S

(12) **United States Design Patent** (10) **Patent No.:** **US D916,294 S**
Murray et al. (45) **Date of Patent:** **** Apr. 13, 2021**

(54) **ILLUMINATION AND IMAGING DEVICE**

(71) Applicant: **Stryker European Operations Limited**, Carrigtwohill (IE)

(72) Inventors: **Gavin Michael Murray**, Vancouver (CA); **Gregory Vincent Browne**, Vancouver (CA); **James Elliott Cameron**, Victoria (CA)

(73) Assignee: **Stryker European Operations Limited**, Carrigtwohill (IE)

(**) Term: **15 Years**

(21) Appl. No.: **29/562,795**

(22) Filed: **Apr. 28, 2016**

(51) **LOC (13) Cl.** **24-02**

(52) **U.S. Cl.**
 USPC **D24/186**

(58) **Field of Classification Search**
 USPC D24/186, 137, 138, 158, 180, 209;
 D14/420, 426-430, 453, 346, 341, 347,
 D14/412; D13/184, 107; 235/462, 44,
 235/46, 487, 472.01, 472.02
 CPC A61B 5/0408; A61B 5/0077; A61B 46/10;
 G06K 7/00; G06K 7/10386; G06K
 7/10801; H06K 7/10732; G06Q 20/20;
 G02B 27/0006; G02B 23/24; G02B
 2/2492; G06B 23/22; H04N 5/2351;
 H04N 5/2354
 See application file for complete search history.

3,790,248 A	2/1974	Kellow
3,931,593 A	1/1976	Marshall
3,970,373 A	7/1976	Pledger
3,971,068 A	7/1976	Gerhardt et al.
4,037,866 A	7/1977	Price
4,066,330 A	1/1978	Jones
4,115,812 A	9/1978	Akatsu
4,149,190 A	4/1979	Wessler et al.
4,158,504 A	6/1979	de Ponteves et al.
4,200,801 A	4/1980	Schuresko
4,260,217 A	4/1981	Traeger et al.
4,318,395 A	3/1982	Tawara
4,355,325 A	10/1982	Nakamura et al.
4,378,571 A	3/1983	Handy
4,449,535 A	5/1984	Renault
4,471,766 A	9/1984	Terayama
4,532,918 A	8/1985	Wheeler
4,556,057 A	12/1985	Hiruma et al.
4,575,632 A	3/1986	Lange
4,597,630 A	7/1986	Brandstetter et al.
4,611,888 A	9/1986	Prenovitz et al.
4,638,365 A	1/1987	Kato
4,656,508 A	4/1987	Yokota
4,660,982 A	4/1987	Okada
4,688,905 A	8/1987	Okamura
4,717,952 A	1/1988	Kohayakawa et al.
4,742,388 A	5/1988	Cooper et al.
4,768,513 A	9/1988	Suzuki
4,786,813 A	11/1988	Svanberg et al.
4,799,104 A	1/1989	Hosoya et al.
4,806,005 A	2/1989	Schneider et al.
4,821,117 A	4/1989	Sekiguchi
4,837,625 A	6/1989	Douziech et al.
4,852,985 A	8/1989	Fujihara et al.
4,856,495 A	8/1989	Tohjoh et al.
4,885,634 A	12/1989	Yabe
4,895,145 A	1/1990	Joffe et al.
4,930,516 A	6/1990	Alfano et al.
4,930,883 A	6/1990	Salzman
4,951,135 A	8/1990	Sasagawa et al.
4,953,539 A	9/1990	Nakamura et al.
4,954,897 A	9/1990	Ejima et al.
4,974,936 A	12/1990	Ams et al.
5,001,556 A	3/1991	Nakamura et al.
5,007,408 A	4/1991	Ieoka
5,028,128 A	7/1991	Onuki
5,034,888 A	7/1991	Uehara et al.
5,041,852 A	8/1991	Misawa et al.
5,115,308 A	5/1992	Onuki
5,121,220 A	6/1992	Nakamoto
5,128,803 A	7/1992	Sprafke
5,132,837 A	7/1992	Kitajima
5,134,662 A	7/1992	Bacus et al.

(56) **References Cited**

U.S. PATENT DOCUMENTS

1,290,744 A	1/1919	Hollander
D62,892 S	8/1923	Dinkelspiel
2,453,336 A	11/1948	Orser
2,857,523 A	10/1958	Corso
3,215,029 A	11/1965	Woodcock
3,582,178 A	6/1971	Boughton et al.
3,671,098 A	6/1972	Rotter
3,749,494 A	7/1973	Hodges

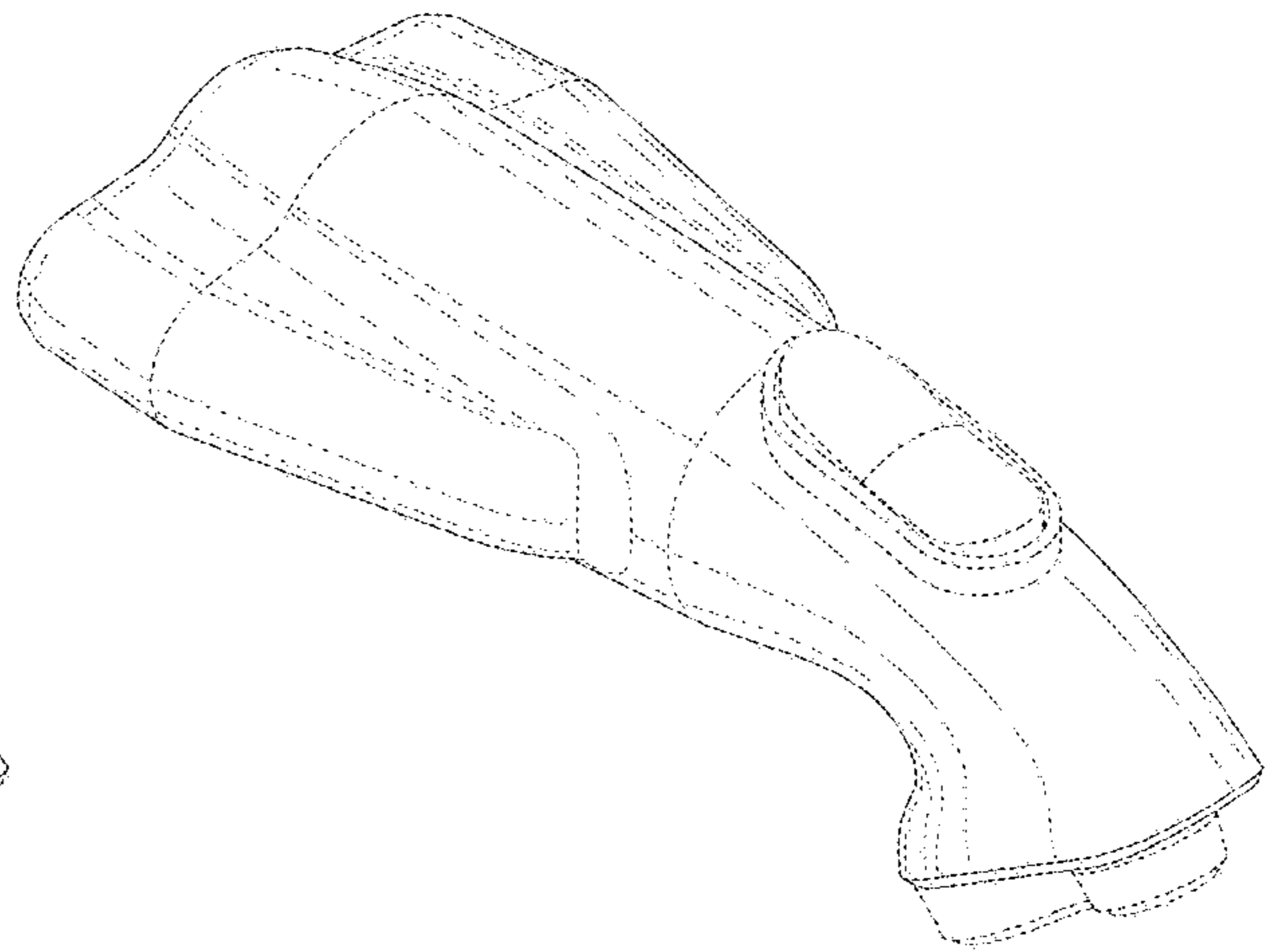
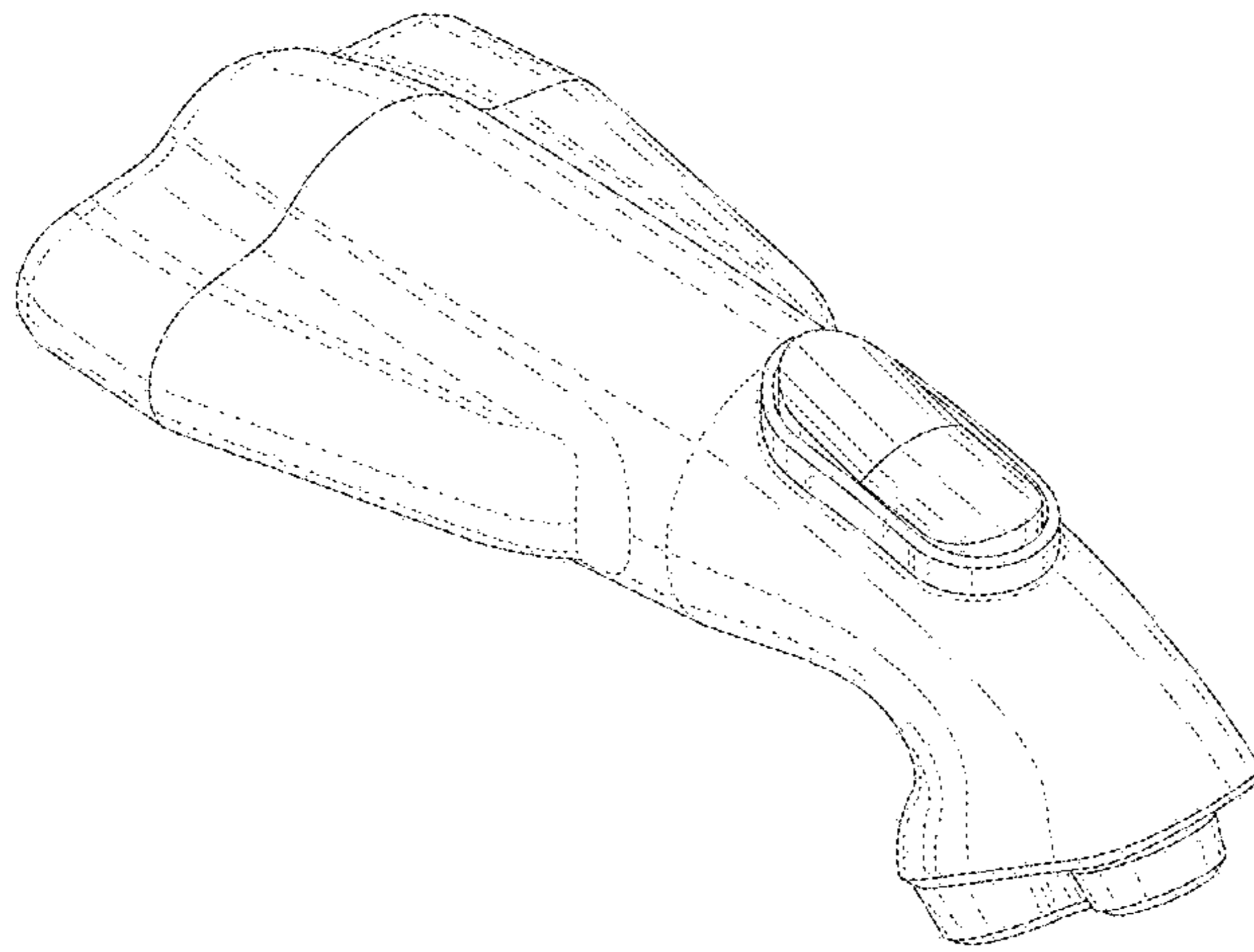

US D916,294 S

5,159,398 A	10/1992	Maekewa et al.	6,120,435 A	9/2000	Eino
5,165,079 A	11/1992	Schulz-Hennig	6,147,705 A	11/2000	Krauter et al.
5,205,280 A	4/1993	Dennison, Jr. et al.	6,148,227 A	11/2000	Wagniu ères et al.
5,208,651 A	5/1993	Buican	6,161,035 A	12/2000	Furusawa
5,214,503 A	5/1993	Chiu et al.	6,181,414 B1	1/2001	Raz et al.
5,225,883 A	7/1993	Carter et al.	6,192,267 B1	2/2001	Scherninski et al.
5,255,087 A	10/1993	Nakamura et al.	6,212,425 B1	4/2001	Irion et al.
5,278,642 A	1/1994	Danna et al.	6,226,126 B1	5/2001	Conemac
5,282,082 A	1/1994	Espie et al.	6,258,576 B1	7/2001	Richards-Kortum et al.
5,295,017 A	3/1994	Brown	D446,524 S *	8/2001	Bontly D14/426
RE34,622 E	5/1994	Ledley	6,280,378 B1	8/2001	Kazuhiro et al.
5,365,057 A	11/1994	Morley et al.	6,293,911 B1	9/2001	Imaizumi et al.
5,371,355 A	12/1994	Wodecki	6,315,712 B1	11/2001	Rovegno
5,377,686 A	1/1995	O'Rourke et al.	6,332,092 B1	12/2001	Deckert et al.
5,379,756 A	1/1995	Pileski et al.	6,364,829 B1	4/2002	Fulghum
5,408,263 A	4/1995	Kikuchi et al.	6,364,831 B1	4/2002	Crowley
5,410,363 A	4/1995	Capen et al.	D456,809 S *	5/2002	Schlieffers D14/426
5,419,323 A	5/1995	Kittrell et al.	6,419,628 B1	7/2002	Rudischhauser et al.
5,420,628 A	5/1995	Poulsen et al.	6,422,994 B1	7/2002	Kaneko et al.
5,421,337 A	6/1995	Richards-Kortum et al.	6,462,770 B1	10/2002	Cline et al.
5,424,841 A	6/1995	Van Gelder et al.	6,510,338 B1	1/2003	Irion et al.
5,426,530 A	6/1995	Copenhaver et al.	6,526,213 B1	2/2003	Ilenda et al.
5,430,476 A	7/1995	Häfele et al.	6,529,239 B1	3/2003	Dyck et al.
D362,435 S *	9/1995	Charych D14/428	6,529,768 B1	3/2003	Hakamata
D362,465 S	9/1995	Gallenmore	6,537,211 B1	3/2003	Wang et al.
5,481,401 A	1/1996	Kita et al.	6,544,102 B2	4/2003	Schäfer et al.
5,485,203 A	1/1996	Nakamura et al.	6,571,119 B2	5/2003	Hayashi
5,490,015 A	2/1996	Umeyama et al.	6,596,996 B1	7/2003	Stone et al.
5,507,287 A	4/1996	Palcic et al.	6,603,552 B1	8/2003	Cline et al.
5,515,449 A	5/1996	Tsuruoka et al.	6,639,664 B2	10/2003	Haan et al.
5,535,052 A	7/1996	Jörgens	6,652,452 B1	11/2003	Seifert et al.
5,536,236 A	7/1996	Yabe et al.	6,750,971 B2	6/2004	Overbeck et al.
5,557,451 A	9/1996	Copenhaver et al.	6,772,003 B2	8/2004	Kaneko et al.
5,585,846 A	12/1996	Kim	6,773,392 B2	8/2004	Kikuchi et al.
5,590,660 A	1/1997	MacAulay et al.	6,786,865 B2	9/2004	Dhindsa
5,596,654 A	1/1997	Tanaka	6,821,245 B2	11/2004	Cline et al.
5,646,680 A	7/1997	Yajima	6,826,424 B1	11/2004	Zeng et al.
5,647,368 A	7/1997	Zeng et al.	6,898,458 B2	5/2005	Zeng et al.
5,647,840 A	7/1997	D'Amelio et al.	6,899,675 B2	5/2005	Cline et al.
5,667,472 A	9/1997	Finn et al.	6,922,583 B1	7/2005	Perelman et al.
5,677,724 A	10/1997	Takizawa et al.	6,958,862 B1	10/2005	Joseph
5,682,567 A	10/1997	Spruck et al.	6,960,165 B2	11/2005	Ueno et al.
5,689,354 A	11/1997	Orino	7,043,291 B2	5/2006	Sendai
5,695,049 A	12/1997	Bauman	D524,985 S *	7/2006	Lukan D28/46
5,697,373 A	12/1997	Richards-Kortum et al.	D524,987 S *	7/2006	Lukan D28/48
5,713,364 A	2/1998	DeBaryshe et al.	7,150,552 B2	12/2006	Weidel
5,729,382 A	3/1998	Morita et al.	7,179,222 B2	2/2007	Imaizumi et al.
5,749,830 A	5/1998	Kaneko et al.	7,235,045 B2	6/2007	Wang et al.
5,769,792 A	6/1998	Palcic et al.	7,236,815 B2	6/2007	Richards-Kortum et al.
5,772,355 A	6/1998	Ross et al.	7,253,894 B2	8/2007	Zeng et al.
5,772,580 A	6/1998	Utsui et al.	7,324,674 B2	1/2008	Ozawa et al.
5,827,190 A	10/1998	Palcic et al.	7,333,270 B1	2/2008	Pochapsky et al.
5,833,617 A	11/1998	Hayashi	7,341,557 B2	3/2008	Cline et al.
5,838,001 A	11/1998	Minakuchi et al.	7,385,772 B2	6/2008	Forkey et al.
5,840,017 A	11/1998	Furuswaba et al.	7,420,151 B2	9/2008	Fengler et al.
5,852,498 A	12/1998	Youvan et al.	7,479,990 B2	1/2009	Imaizumi et al.
5,891,016 A	4/1999	Utsui et al.	D599,799 S *	9/2009	Di Bari D14/428
5,897,269 A	4/1999	Ross et al.	D603,408 S *	11/2009	Fitch D14/426
5,971,918 A	10/1999	Zanger	D606,544 S *	12/2009	Di Bari D14/426
5,973,315 A	10/1999	Saldana et al.	7,697,975 B2	4/2010	Zeng
5,984,861 A	11/1999	Crowley	7,704,206 B2	4/2010	Suzuki et al.
5,986,271 A	11/1999	Lazarev et al.	7,722,534 B2	5/2010	Cline et al.
5,986,642 A	11/1999	Ueda et al.	7,777,191 B2	8/2010	Olcott et al.
5,990,996 A	11/1999	Sharp	7,798,955 B2	9/2010	Ishihara et al.
5,999,240 A	12/1999	Sharp et al.	7,811,229 B2	10/2010	Sugimoto
6,002,137 A	12/1999	Hayashi	7,928,352 B2	4/2011	Toda
6,004,263 A	12/1999	Nakaichi et al.	8,035,067 B2	10/2011	Toda
6,008,889 A	12/1999	Zeng et al.	D653,811 S *	2/2012	BenZion D24/133
6,021,344 A	2/2000	Lui et al.	8,140,147 B2	3/2012	Maynard et al.
6,028,622 A	2/2000	Suzuki	8,285,015 B2	10/2012	Demos
6,030,339 A	2/2000	Tatsuno et al.	8,337,400 B2	12/2012	Mizuyoshi
6,059,719 A	5/2000	Yamamoto et al.	8,361,775 B2	1/2013	Flower
6,059,720 A	5/2000	Furusawa et al.	D677,258 S *	3/2013	Mistkawi D14/426
6,061,591 A	5/2000	Freitag et al.	8,408,269 B2	4/2013	Fengler et al.
6,069,689 A	5/2000	Zeng et al.	8,408,772 B2	4/2013	Li
6,070,096 A	5/2000	Hayashi	D682,277 S *	5/2013	Tasselli D14/426
6,095,982 A	8/2000	Richards-Kortum et al.	8,448,867 B2	5/2013	Liu et al.
6,099,466 A	8/2000	Sano et al.	8,473,035 B2	6/2013	Frangioni
6,110,106 A	8/2000	MacKinnon et al.	8,498,695 B2	7/2013	Westwick et al.

US D916,294 S

D692,004 S *	10/2013	Man	D14/426	2004/0156124 A1	8/2004	Okada	
D692,892 S *	11/2013	Mistkawi	D14/426	2004/0186351 A1	9/2004	Katsuichi et al.	
8,630,698 B2	1/2014	Fengler et al.		2004/0218115 A1	11/2004	Kawana et al.	
8,721,532 B2	5/2014	Takei et al.		2004/0225222 A1	11/2004	Zeng et al.	
8,736,748 B2	5/2014	Takita		2004/0245350 A1	12/2004	Zeng	
8,759,243 B2	6/2014	Coffy et al.		2004/0263643 A1	12/2004	Imaizumi et al.	
8,773,756 B2	7/2014	Tesar et al.		2005/0027166 A1	2/2005	Matsumoto et al.	
8,790,253 B2	7/2014	Sunagawa et al.		2005/0096505 A1	5/2005	Imaizumi et al.	
8,830,339 B2	9/2014	Velarde et al.		2005/0140270 A1	6/2005	Henson et al.	
D719,574 S *	12/2014	Alegiani	D14/426	2005/0143627 A1	6/2005	Cline et al.	
8,961,403 B2	2/2015	Cline et al.		2005/0154319 A1	7/2005	Cline et al.	
D723,563 S *	3/2015	Alegiani	D14/426	2005/0171440 A1	8/2005	Maki et al.	
8,979,301 B2	3/2015	Moore		2005/0182291 A1	8/2005	Hirata	
D726,186 S *	4/2015	Jenkins	D14/426	2005/0182321 A1	8/2005	Frangioni	
D734,339 S *	7/2015	Zhou	D14/428	2005/0203421 A1	9/2005	Zeng et al.	
9,125,552 B2	9/2015	Dunki-Jacobs et al.		2005/0256373 A1	11/2005	Bar-Or et al.	
9,143,746 B2	9/2015	Westwick et al.		2005/0273011 A1	12/2005	Hattery et al.	
9,173,554 B2	11/2015	Fengler et al.		2005/0280783 A1	12/2005	Yamasaki et al.	
9,282,305 B2	3/2016	Kikuchi		2005/0288593 A1	12/2005	Geordakoudi et al.	
9,294,691 B2	3/2016	Ooki		2006/0002141 A1	1/2006	Ouderkirk et al.	
9,295,392 B2	3/2016	Douplik et al.		2006/0004292 A1	1/2006	Beylin	
9,386,909 B2	7/2016	Fengler et al.		2006/0017913 A1	1/2006	Kawamata et al.	
9,407,838 B2	8/2016	Butte et al.		2006/0089554 A1	4/2006	Ishihara et al.	
9,435,496 B2	9/2016	Moore		2006/0094109 A1	5/2006	Trainer	
9,577,012 B2	2/2017	Ooki		2006/0146322 A1	7/2006	Komachi et al.	
9,642,532 B2	5/2017	Fengler et al.		2006/0149133 A1	7/2006	Sugimoto et al.	
D791,137 S *	7/2017	Wang	D14/428	2006/0155166 A1	7/2006	Takahashi et al.	
9,814,378 B2	11/2017	Moore		2006/0211915 A1	9/2006	Takeuchi et al.	
D815,928 S *	4/2018	Rummel	D7/700	2006/0215406 A1	9/2006	Thrailkill	
D826,234 S *	8/2018	Zhou	D14/428	2006/0217594 A1	9/2006	Ferguson	
D835,284 S *	12/2018	Barker	D24/186	2006/0241496 A1	10/2006	Fengler et al.	
D835,285 S *	12/2018	Barker	D24/186	2006/0247537 A1	11/2006	Matsumoto	
10,356,334 B2	7/2019	Moore et al.		2006/0250696 A1	11/2006	McGuire	
2001/0016679 A1	8/2001	Futatsugi et al.		2006/0258910 A1	11/2006	Stefanchik et al.	
2001/0028458 A1	10/2001	Xiao		2007/0041195 A1	2/2007	Chen	
2001/0049473 A1	12/2001	Hayashi		2007/0091634 A1	4/2007	Sakurada	
2002/0013937 A1	1/2002	Ostanevich et al.		2007/0177152 A1	8/2007	Tearney et al.	
2002/0016533 A1	2/2002	Marchitto et al.		2007/0203413 A1	8/2007	Frangioni	
2002/0021355 A1	2/2002	Utsui et al.		2007/0213593 A1	9/2007	Nakaoka	
2002/0035330 A1	3/2002	Cline et al.		2007/0229309 A1	10/2007	Tomita et al.	
2002/0076480 A1	6/2002	Hsieh et al.		2008/0021274 A1	1/2008	Bayer et al.	
2002/0138008 A1	9/2002	Tsujita et al.		2008/0024868 A1	1/2008	Okamura	
2002/0143243 A1	10/2002	Geordakoudi et al.		2008/0027280 A1	1/2008	Fengler et al.	
2002/0148902 A1 *	10/2002	Schlieffers	G06K 7/10881 235/472.01	2008/0039697 A1	2/2008	Morishita	
				2008/0074752 A1	3/2008	Chaves et al.	
2002/0155619 A1	10/2002	Kurihara et al.		2008/0177140 A1	7/2008	Cline et al.	
2002/0156380 A1	10/2002	Feld et al.		2008/0208006 A1	8/2008	Farr	
2002/0161282 A1	10/2002	Fulghum		2008/0217411 A1 *	9/2008	Ledwith	G06K 7/10881 235/472.02
2002/0161283 A1	10/2002	Sendai					
2002/0161284 A1	10/2002	Tanaka		2008/0246920 A1	10/2008	Buczek et al.	
2002/0168096 A1	11/2002	Hakamata et al.		2009/0012361 A1	1/2009	MacKinnon et al.	
2002/0175993 A1	11/2002	Ueno et al.		2009/0021739 A1	1/2009	Tsujita et al.	
2002/0177778 A1	11/2002	Averback et al.		2009/0036734 A1	2/2009	Dunki-Jacobs et al.	
2002/0186478 A1	12/2002	Watanabe et al.		2009/0040754 A1	2/2009	Brukilacchio et al.	
2002/0196335 A1	12/2002	Ozawa		2009/0052185 A1	2/2009	Toriyama et al.	
2003/0002036 A1	1/2003	Haan et al.		2009/0114799 A1	5/2009	Maeda	
2003/0042493 A1	3/2003	Kazakevich		2009/0114803 A1	5/2009	Yamaguchi	
2003/0063398 A1	4/2003	Abe et al.		2009/0122135 A1	5/2009	Matsui	
2003/0080193 A1	5/2003	Ryan et al.		2009/0122152 A1	5/2009	Yamaguchi et al.	
2003/0117491 A1	6/2003	Avni et al.		2009/0124854 A1	5/2009	Yamaguchi et al.	
2003/0135092 A1	7/2003	Cline et al.		2009/0153797 A1	6/2009	Allon et al.	
2003/0153811 A1	8/2003	Muckner		2009/0181339 A1	7/2009	Liang et al.	
2003/0158470 A1	8/2003	Wolters et al.		2009/0201577 A1	8/2009	LaPlante et al.	
2003/0191368 A1	10/2003	Wang et al.		2009/0218405 A1 *	9/2009	Joseph	G06K 7/10732 235/462.42
2003/0229270 A1	12/2003	Suzuki et al.					
2004/0006276 A1	1/2004	Demos et al.		2009/0290149 A1	11/2009	Roth	
2004/0010183 A1	1/2004	Dhindsa		2010/0065641 A1	3/2010	Liu et al.	
2004/0020990 A1 *	2/2004	Havens	G06K 7/10574 235/472.01	2010/0087741 A1	4/2010	Douplik et al.	
				2010/0094136 A1	4/2010	Nakaoka et al.	
2004/0021859 A1	2/2004	Cunningham		2010/0110168 A1	5/2010	Avni et al.	
2004/0037454 A1	2/2004	Ozawa et al.		2010/0110393 A1	5/2010	Chen et al.	
2004/0044275 A1	3/2004	Hakamata		2010/0121146 A1	5/2010	Sugimoto	
2004/0046865 A1	3/2004	Ueno et al.		2010/0125164 A1	5/2010	LaBombard	
2004/0133073 A1	7/2004	Berci et al.		2010/0155487 A1	6/2010	Liu et al.	
2004/0134990 A1 *	7/2004	Fitch	G06K 7/10881 235/472.01	2010/0157039 A1	6/2010	Sugai	
				2010/0168588 A1	7/2010	Matsumoto et al.	
2004/0143162 A1	7/2004	Krattiger et al.		2010/0198010 A1	8/2010	Cline et al.	
2004/0148141 A1	7/2004	Tsujita et al.		2010/0208487 A1	8/2010	Li	
2004/0149998 A1	8/2004	Henson et al.		2010/0277817 A1	11/2010	Durell	

US D916,294 S

2010/0308116	A1 *	12/2010	Sani	A45C 11/00	JP	H07-250812	A	10/1995
				235/472.01	JP	H07-327913	A	12/1995
2011/0024506	A1 *	2/2011	Nunnink	G06K 7/10732	JP	H08-126605	A	5/1996
				235/472.01	JP	08-140928	A2	6/1996
2011/0032350	A1	2/2011	Kikuchi et al.		JP	08-140929	A2	6/1996
2011/0073658	A1 *	3/2011	Vassura	G06K 7/10881	JP	H08-224208	A	9/1996
				235/472.01	JP	H08-224209	A	9/1996
2011/0235017	A1	9/2011	Iwasaki		JP	H08-224210	A	9/1996
2011/0244506	A1	10/2011	Sutter et al.		JP	H08-224240	A	9/1996
2011/0270092	A1	11/2011	Kang et al.		JP	H08-252218	A	10/1996
2011/0290889	A1 *	12/2011	Tamburrini	G06K 7/10881	JP	H09-19408	A	1/1997
				235/470	JP	09-066023	A2	3/1997
2012/0006897	A1 *	1/2012	Barkan	G06K 7/10722	JP	09-070384	A2	3/1997
				235/472.01	JP	H10-127563	A	5/1998
2012/0044462	A1	2/2012	Kaji		JP	H10-151104	A	6/1998
2012/0150046	A1	6/2012	Watson et al.		JP	10-225427	A2	8/1998
2012/0256002	A1 *	10/2012	O'Donnell	G06K 7/10386	JP	H10-201700	A	8/1998
				235/472.01	JP	H10-201707	A	8/1998
2012/0319645	A1 *	12/2012	O'Donnell	H02J 7/025	JP	H10-225426	A	8/1998
				320/108	JP	H10-243915	A	9/1998
2013/0008964	A1 *	1/2013	Hawley	G06K 7/10851	JP	H10-243920	A	9/1998
				235/472.01	JP	H10-308114	A	11/1998
2013/0237762	A1	9/2013	Fengler et al.		JP	H10-309281	A	11/1998
2014/0071328	A1	3/2014	Miesak		JP	H10-309282	A	11/1998
2014/0078378	A1	3/2014	Demers et al.		JP	H10-321005	A	12/1998
2014/0139893	A1	5/2014	Sugiyama et al.		JP	H10-328129	A	12/1998
2014/0187967	A1	7/2014	Wood et al.		JP	H11-47079	A	2/1999
2014/0194687	A1	7/2014	Fengler et al.		JP	11-089789	A2	4/1999
2015/0184811	A1	7/2015	Moore		JP	H11-104059	A	4/1999
2015/0230698	A1	8/2015	Cline et al.		JP	H11-104060	A	4/1999
2015/0320296	A1	11/2015	Morita		JP	H11-104061	A	4/1999
2015/0381909	A1	12/2015	Butte et al.		JP	H11-104070	A	4/1999
2016/0041098	A1	2/2016	Hirawake et al.		JP	H11-113839	A	4/1999
2016/0044253	A1	2/2016	Dainty et al.		JP	H11-155812	A	4/1999
2016/0100763	A1	4/2016	Fengler et al.		JP	H11-244220	A	9/1999
2016/0249019	A1	8/2016	Westwick et al.		JP	H11-332819	A	12/1999
2016/0360956	A1	12/2016	Moore		JP	2000-504968	A	4/2000
2017/0064257	A1	3/2017	Westwick et al.		JP	2000-245693	A	9/2000
2017/0064258	A1	3/2017	Westwick et al.		JP	2000-354583	A	12/2000
2017/0142314	A1	5/2017	Moore et al.		JP	2001-78205	A	3/2001
2017/0167980	A1	6/2017	Dimitriadis et al.		JP	2002-000560	A	1/2002
2017/0209050	A1	7/2017	Fengler et al.		JP	02-049302	A	2/2002
2017/0273567	A1	9/2017	Fengler et al.		JP	2002-244122	A	8/2002
2017/0354392	A1	12/2017	Fengler et al.		JP	2003-045210	A	2/2003
					JP	2004-024611	A	1/2004
					JP	2004-094043	A	3/2004
					JP	2004-163902	A	6/2004
					JP	2004-520105	A	7/2004
					JP	2004-247156	A	9/2004
					JP	2004-289545	A	10/2004
					JP	2004-292722	A	10/2004
					JP	2005-010315	A	1/2005
					JP	2005-058618	A2	3/2005
					JP	2005-058619	A2	3/2005
					JP	2005-058620	A2	3/2005
					JP	2005-080819	A2	3/2005
					JP	2005-081079	A2	3/2005
					JP	2005-149996	A	6/2005
					JP	2005-292404	A	10/2005
					JP	2006-003103	A	1/2006
					JP	2006-073767	A	3/2006
					JP	2006-087764	A	4/2006
					JP	2006-525494	A	11/2006
					JP	2007-029453	A	2/2007
					JP	2007-072392	A	3/2007
					JP	2007-089840	A	4/2007
					JP	2009-259703	A	11/2009
					JP	2010-107751	A	5/2010
					JP	2010-117442	A	5/2010
					JP	2010-524194	A	7/2010
					JP	2011-500921	A	1/2011
					JP	2011-072424	A	4/2011
					JP	2011-169819	A	9/2011
					JP	2011-528918	A	12/2011
					JP	5231625	B2	7/2013
					JP	2014-123941	A	7/2014
					JP	5859578	B2	2/2016
					RU	99592	U1	11/2010
					WO	WO-1993/04648	A1	3/1993

FOREIGN PATENT DOCUMENTS

CN	101726980	A	6/2010
CN	101828139	A	9/2010
CN	201974160	U	9/2011
DE	19535114	A1	3/1996
DE	19608027	A1	9/1996
EP	0512965	A1	11/1992
EP	0672379	A1	9/1995
EP	0774865	A2	5/1997
EP	0792618	A1	9/1997
EP	0671706	B1	6/1999
EP	1374755	A1	1/2004
EP	1883337	A1	2/2008
EP	2051603	A1	4/2009
EP	2859837	A1	4/2015
FR	2671405	A1	7/1992
JP	S60-246733	A	12/1985
JP	S61-159936	A	7/1986
JP	H-01-135349	A	5/1989
JP	03-97439	A	4/1991
JP	03-97441	A	4/1991
JP	03-97442	A	4/1991
JP	05-115435	A	5/1993
JP	06-125911	A	5/1994
JP	H07-155285	A	6/1995
JP	H07-155286	A	6/1995
JP	H07-155290	A	6/1995
JP	H07-155291	A	6/1995
JP	H07-155292	A	6/1995
JP	H07-204156	A	8/1995
JP	H07-222712	A	8/1995
JP	H07-250804	A	10/1995

WO	WO-1994/13191	A1	6/1994
WO	WO-1995/26673	A2	10/1995
WO	WO-1998/24360	A1	6/1998
WO	WO-1999/01749	A1	1/1999
WO	WO-1999/53832	A1	10/1999
WO	WO-2000/42910	A1	7/2000
WO	WO-2000/54652	A1	9/2000
WO	WO-2002/007587	A2	1/2002
WO	WO-2002/50518	A2	6/2002
WO	WO-2003/059159	A2	7/2003
WO	WO-2006/116847	A1	11/2006
WO	WO-2007/081707	A2	7/2007
WO	WO-2008/011722	A1	1/2008
WO	WO-2008/071240	A1	6/2008
WO	WO-2009/033021	A2	3/2009
WO	WO-2013/160279	A1	10/2013
WO	WO-2014/176375	A2	10/2014
WO	WO-2016/055837	A1	4/2016

OTHER PUBLICATIONS

US 6,692,429 B1, 02/2004, Imaizumi et al. (withdrawn)

Alfano, R.R. et al. (Oct. 1987). "Fluorescence Spectra From Cancerous and Normal Human Breast and Lung Tissues," *IEEE Journal of Quantum Electronics* QE-23(10):1806-1811.

Andersson-Engels, S. et al. (Mar. 1989). "Tissue Diagnostics Using Laser Induced Fluorescence," *Ber. Bunsenges Physical Chemistry* 93(3):335-342.

Australian Office Action dated Jun. 28, 2018 for Australian Patent Application No. 2016351730 filed on Nov. 10, 2016, five pages.

Australian Office Action dated May 10, 2019 for Australian Patent Application No. 2016351730 filed on Nov. 10, 2016, ten pages.

Bhunchet, E. et al. (Apr. 2002). "Fluorescein Electronic Endoscopy: A Novel Method for Detection of Early Stage Gastric Cancer Not Evident to Routine Endoscopy," *Gastrointestinal Endoscopy* 55(4):562-571.

Canadian Office Action dated Feb. 1, 2017 for Canadian Patent Application No. 171282, filed on Oct. 27, 2016, two pages.

Canadian Office Action dated Feb. 19, 2019 for CA Patent Application No. 2,998,920 filed on Mar. 16, 2018, four pages.

Chinese Notice of Allowance dated Jun. 19, 2017 for Chinese Patent Application No. 201280022284.3, filed on Nov. 7, 2013, four pages.

Chinese Office Action dated Jul. 29, 2016 for Chinese Patent Application No. 2012800222843 filed on Mar. 8, 2012, eight pages.

Chinese Office Action dated Mar. 14, 2017 for Chinese Patent Application No. 201280022284.3, filed on Nov. 7, 2013, seven pages.

Chinese Office Action dated Nov. 24, 2015 for Chinese Patent Application No. 2012800222843 filed on Mar. 8, 2012, sixteen pages.

Chinese Office Action dated Sep. 26, 2018 for Chinese Patent Application No. 2018092001857100, filed on Sep. 4, 2017, nineteen pages.

Dawson, J.B. et al. (Jul. 1980). "A Theoretical and Experimental Study of Light Absorption and Scattering by *In Vivo* Skin," *Phys. Med. Biol.* 25(4):695-709.

European Notice of Allowance dated Feb. 28, 2018 for EP Patent Application No. 12754208.2 filed Oct. 4, 2013, six pages.

European Notice of Allowance dated Jul. 12, 2018 for EP Patent Application No. 12754208.2 filed Oct. 4, 2013, two pages.

European Notice of Allowance dated Jun. 22, 2017 for EP Patent Application No. 08706262.6 filed on Aug. 2021, 2009, two pages.

European Notice of Allowance dated Mar. 6, 2018 for EP Patent Application No. 13180297.7 filed Aug. 13, 2013, seven pages.

European Notice of Allowance dated Mar. 18, 2019 for EP Patent Application No. 09819758.5, filed on May 4, 2011, seven pages.

European Notice of Allowance dated May 25, 2018 for EP Patent Application No. 13180297.7 filed Aug. 13, 2013, two pages.

European Notice of Allowance dated Nov. 25, 2016 for EP Patent Application No. 08706262.6 filed on Aug. 21, 2009, eight pages.

European Office Action dated Apr. 6, 2017, for EP Patent Application No. 09819758.5, filed on May 4, 2011, five pages.

European Office Action dated Apr. 13, 2017, for EP Patent Application No. 12754208.2 filed on Oct. 4, 2013, five pages.

European Office Action dated Dec. 3, 2015 for EP Patent Application No. 08706262.6 filed on Jan. 23, 2008; fifteen pages.

European Office Action dated Jan. 23, 2017 for EP Patent Application No. 16186321.2 filed on Aug. 30, 2016, two pages.

European Office Action dated Nov. 3, 2015 for EP Patent Application No. 12754208.2 filed Oct. 4, 2013, four pages.

European Office Action dated Nov. 19, 2015 for EP Patent Application No. 07 785 001.4, filed on Jul. 30, 2007, four pages.

European Office Action dated Sep. 29, 2015, for EP Patent Application No. 09721252.6 filed Mar. 18, 2009; five pages.

European Search Report dated Dec. 21, 2016 for EP Patent Application No. 16186321.2 filed on Aug. 30, 2016, nine pages.

European Search Report dated Jan. 24, 2012 for EP Patent Application No. 07785001.4 filed on Jul. 30, 2007, seven pages.

European Search Report dated Jul. 17, 2014 for EP Patent Application No. 09721252.6 filed Mar. 18, 2009; eleven pages.

European Search Report dated Oct. 1, 2014 for EP Patent Application No. 12754208.2 filed on Mar. 8, 2012, five pages.

European Search Report dated Oct. 9, 2013, for European Patent Application No. 06721854.5, filed on May 4, 2005, seven pages.

European Search Report dated Sep. 20, 2013 for EP Patent Application No. 08706262.6 filed on Jan. 23, 2008, five pages.

Georgakoudi, I et al. (2003). "Quantitative Characterization of Biological Tissue Using Optical Spectroscopy," in Chapter 31 of Biomedical Photonics Handbook Tuan Vo-Dinh (ed.), CRC Press, New York, thirty three pages.

Georgakoudi, I et al. (Apr. 2005). "Characterization of Dysplastic Tissue Morphology and Biochemistry in Barrett's Esophagus using Diffuse Reflectance and Light Scattering Spectroscopy," *Techniques in Gastrointestinal Endoscopy* 7(2):100-105.

Hubel, P.M. et al. (2004). "Spatial Frequency Response of Color Image Sensors: Bayer Color Filters and Foveon X3," *Proceedings of SPIE* 5301:402-406.

Hung, J. et al. (1991). "Autofluorescence of Normal and Malignant Bronchial Tissue," *Lasers in Surgery and Medicine* 11(2):99-105.

Indian Office Action dated Jan. 31, 2018 for Indian Patent Application No. 6532/DELNP/2010 filed on Sep. 16, 2010, five pages.

Indian Office Action dated Jun. 26, 2018 for Indian Patent Application No. 8678/DELNP/2013 filed on Mar. 8, 2012, five pages.

International Preliminary Report on Patentability dated Dec. 27, 2018 for International Patent Application No. PCT/CA2017/050734 filed on Jun. 14, 2017, six pages.

International Preliminary Report on Patentability dated Feb. 3, 2009 for International Patent Application No. PCT/CA2007/001335 filed on Jul. 30, 2007, five pages.

International Preliminary Report on Patentability dated May 24, 2018 for International Patent Application No. PCT/CA2016/051315 filed on Nov. 10, 2016, nine pages.

International Preliminary Report on Patentability dated Nov. 6, 2007 for International Patent Application No. PCT/CA2006/000669, filed on Apr. 27, 2006, nine pages.

International Preliminary Report on Patentability dated Sep. 21, 2010 for International Patent Application No. PCT/US2009/037506, filed on Mar. 18, 2009, seven pages.

International Search Report and written Opinion dated Apr. 24, 2017 for International Patent Application No. PCT/CA2017/050083, filed on Jan. 26, 2017, seven pages.

International Search Report and written Opinion dated Feb. 10, 2017 for International Patent Application No. PCT/CA2016/051315 filed on Nov. 10, 2016, thirteen pages.

International Search Report and Written Opinion dated Sep. 18, 2017 for International Patent Application No. PCT/CA2017/050734, filed on Jun. 14, 2017, eight pages.

International Search Report dated Aug. 3, 2006, for International Patent Application No. PCT/CA2006/000669, filed on Apr. 27, 2006, three pages.

International Search Report dated Aug. 3, 2012, for International Patent Application No. PCT/IB2012/000601, filed on Mar. 8, 2012, three pages.

International Search Report dated Dec. 7, 2007, for International Patent Application No. PCT/CA2007/001335, filed on Jul. 30, 2007, two pages.

- International Search Report dated Jan. 21, 2002 for International Patent Application No. PCT/US2001/022198, filed on Jul. 13, 2001, three pages.
- International Search Report dated Jul. 22, 2009 for International Patent Application No. PCT/US09/37506, filed on Mar. 18, 2009, two pages.
- International Search Report dated May 13, 2008 for Intentional Patent Application No. PCT/CA2008/00015, filed on Jan. 8, 2008, one page.
- Invitation to Pay additional Fees and, where Applicable, Protest Fee, mailed on Dec. 22, 2016 for International Patent Application No. PCT/CA2016/051315, filed on Nov. 10, 2016, two pages.
- Japanese Final Office Action dated Aug. 2, 2013 for Japanese Application No. 2008-509275, filed on Apr. 27, 2006, four pages.
- Japanese Notice of Allowance dated Apr. 2, 2018 for Japanese Patent Application No. 2017-018858 filed on Feb. 3, 2017, six pages.
- Japanese Notice of Allowance dated Jan. 5, 2017 for Japanese Patent Application No. 2015-238784, filed on Dec. 7, 2015, six pages.
- Japanese Notice of Allowance dated Nov. 17, 2017 for Japanese Application No. 2016-253736 filed on Dec. 27, 2016, six pages.
- Japanese Notice of Allowance dated Nov. 28, 2016 for Japanese Patent Application No. 2015-245598, filed on Mar. 8, 2012, six pages.
- Japanese Office Action dated Apr. 3, 2015 for Japanese Patent Application No. 2013-058356, filed Mar. 18, 2009, four pages.
- Japanese Office Action dated Apr. 20, 2012 for Japanese Patent Application No. 2011-500921, filed Mar. 18, 2009, four pages.
- Japanese Office Action dated Dec. 8, 2017 for Japanese Patent Application No. 2017-018858 filed on Feb. 3, 2017, six pages.
- Japanese Office dated Dec. 26, 2012 for Japanese Patent Application No. 2011-500921, filed on Mar. 18, 2009, two pages.
- Japanese Office Action dated Feb. 17, 2012 for Japanese Application No. 2008-509275, filed on Apr. 27, 2006, six pages.
- Japanese Office Action dated Jul. 22, 2014 for Japanese Patent Application No. 2013-557187 filed Mar. 8, 2012, seven pages.
- Japanese Office Action dated Mar. 9, 2015 for Japanese Patent Application No. 2013-557187, filed Mar. 8, 2012, five pages.
- Japanese Office Action dated May 26, 2014 in Japanese Patent Application No. 2013-058356, filed on Mar. 18, 2009, w/Concise Explanation of the Relevance, three pages.
- Japanese Office Action dated Nov. 11, 2011 for Japanese Application No. 2009-521077, filed on Jul. 30, 2007, four pages.
- Japanese Office Action dated Sep. 14, 2012 for Japanese Application No. 2008-509275, filed on Apr. 27, 2006, seven pages.
- Japanese Office Action dated Sep. 19, 2014 for Japanese Application No. 2013-246636, filed on Apr. 27, 2006, six pages.
- Korean Decision on the Trial Against Final Rejection from the Intellectual Property Tribunal (IPT) dated Sep. 25, 2017 for Korean Patent Application No. 2013-7026479, filed on Oct. 7, 2013, seventeen pages.
- Korean Notice of Allowance dated Dec. 13, 2017 for Korean Patent Application No. 10-2017-7008654, filed on Mar. 29, 2017, three pages.
- Korean Notice of Allowance dated Jan. 2, 2017 for Korean Patent Application No. 10-2015-7033310, filed on Nov. 20, 2015, three pages.
- Korean Office Action dated Aug. 20, 2015 for Korean Patent Application No. 20137026479 filed on Mar. 8, 2012, three pages. (have the translation of the OA, but not the OA itself).
- Korean Office Action dated Aug. 30, 2016 for Korean Patent Application No. 10-2015-7033310 filed on Mar. 8, 2012, seven pages.
- Korean Office Action dated Dec. 8, 2015 for Korean Patent Application No. 20157033310 filed on Mar. 8, 2012, seven pages.
- Korean Office Action dated Jun. 27, 2017 for Korean Patent Application No. 2017-7008654, filed on Mar. 29, 2017, ten pages.
- Lyon, R.E. et al. (2002). "Eyeing the Camera: Into the Next Century," *10 Color and Imaging Conference Final Program & Proceedings* 349-355.
- Russian Notice of Allowance dated Aug. 19, 2016 for Russian Patent Application No. 2013144845/07, filed on Mar. 8, 2012, thirteen pages.
- Török, B. et al. (May 1996). "Simultane digitale Indocyaningrün—und Fluoreszeinangiographie (Simultaneous Digital ICG and Fluorescein Angiography)," *Klin Monatsbl Augenheilkd* 208(5):333-336, (with English Translation of the Introduction).
- U.S. Final Office Action dated Apr. 24, 2015 for U.S. Appl. No. 12/933,512, filed Nov. 24, 2010, nineteen pages.
- U.S. Final Office Action dated Aug. 7, 2017 for U.S. Appl. No. 15/343,038, filed Nov. 3, 2016, eleven pages.
- U.S. Final Office Action dated Aug. 10, 2017 for U.S. Appl. No. 15/343,034, filed Nov. 3, 2016, twelve pages.
- U.S. Final Office Action dated Aug. 11, 2017 for U.S. Appl. No. 14/860,687, filed Sep. 21, 2015, seventeen pages.
- U.S. Final Office Action dated Dec. 14, 2018 for U.S. Appl. No. 15/584,405, filed May 2, 2017, seven pages.
- U.S. Final Office Action dated Feb. 1, 2018 for U.S. Appl. No. 15/584,405, filed May 2, 2017, ten pages.
- U.S. Final Office Action dated Feb. 27, 2017 for U.S. Appl. No. 15/247,419, filed Aug. 25, 2016, ten pages.
- U.S. Final Office Action dated Jan. 11, 2019 for U.S. Appl. No. 15/343,038, filed Nov. 3, 2016, twelve pages.
- U.S. Final Office Action dated Jan. 14, 2019 for U.S. Appl. No. 14/860,687, filed Sep. 21, 2015, sixteen pages.
- U.S. Final Office Action dated Jan. 22, 2019 for U.S. Appl. No. 15/343,034, filed Nov. 3, 2016, twelve pages.
- U.S. Final Office Action dated Jul. 23, 2008 for U.S. Appl. No. 11/122,267, filed May 4, 2016, six pages.
- U.S. Final Office Action dated Jun. 5, 2014 for U.S. Appl. No. 12/761,462, filed Apr. 16, 2010, fourteen pages.
- U.S. Final Office Action dated Jun. 18, 2015 for U.S. Appl. No. 14/154,177, filed Jan. 13, 2014, eight pages.
- U.S. Final Office Action dated Mar. 22, 2016 for U.S. Appl. No. 14/873,842, filed Oct. 2, 2015, eighteen pages.
- U.S. Final Office Action dated May 11, 2011 for U.S. Appl. No. 11/412,715, filed Apr. 26, 2006, eight pages.
- U.S. Final Office Action dated May 21, 2012 for U.S. Appl. No. 11/964,330, filed Dec. 26, 2007, twelve pages.
- U.S. Final Office Action dated Nov. 24, 2009 for U.S. Appl. No. 11/009,965, filed Dec. 10, 2004, fourteen pages.
- U.S. Non Final Office Action dated Apr. 2, 2009 for U.S. Appl. No. 11/009,965, filed Dec. 10, 2004, thirteen pages.
- U.S. Non Final Office Action dated Apr. 3, 2019 for U.S. Appl. No. 15/416,876, filed Jan. 26, 2017, thirteen pages.
- U.S. Non Final Office Action dated Aug. 15, 2018 for U.S. Appl. No. 15/348,664, filed Nov. 10, 2016, eleven pages.
- U.S. Non Final Office Action dated Aug. 16, 2013 for U.S. Appl. No. 12/761,462, filed Apr. 16, 2010, ten pages.
- U.S. Non Final Office Action dated Aug. 16, 2013 for U.S. Appl. No. 12/761,523, filed Apr. 16, 2010, nine pages.
- U.S. Non Final Office Action dated Dec. 10, 2010 for U.S. Appl. No. 11/412,715, filed Apr. 26, 2006, ten pages.
- U.S. Non Final Office Action dated Dec. 14, 2011 for U.S. Appl. No. 11/412,715, filed Apr. 26, 2006, eight pages.
- U.S. Non Final Office Action dated Feb. 1, 2017 for U.S. Appl. No. 14/860,687, filed Sep. 21, 2015, fifteen pages.
- U.S. Non Final Office Action dated Feb. 3, 2010 for U.S. Appl. No. 11/626,308, filed Jan. 23, 2007, eleven pages.
- U.S. Non Final Office Action dated Feb. 5, 2019 for U.S. Appl. No. 15/623,100, filed Jun. 14, 2017, ten pages.
- U.S. Non Final Office Action dated Jan. 2, 2008 for U.S. Appl. No. 11/122,267, filed May 4, 2005, five pages.
- U.S. Non Final Office Action dated Jan. 20, 2016 for U.S. Appl. No. 14/629,473, filed Feb. 23, 2015, fifteen pages.
- U.S. Non Final Office Action dated Jan. 26, 2017 for U.S. Appl. No. 15/343,034, filed Nov. 3, 2016, seventeen pages.
- U.S. Non Final Office Action dated Jan. 27, 2017 for U.S. Appl. No. 15/343,038, filed Nov. 3, 2016, fifteen pages.
- U.S. Non Final Office Action dated Jul. 2, 2013 for U.S. Appl. No. 12/933,512, filed Nov. 24, 2010, twelve pages.
- U.S. Non Final Office Action dated Jul. 17, 2003 for U.S. Appl. No. 09/905,642, filed Jul. 13, 2001, six pages.

U.S. Non Final Office Action dated Jun. 1, 2007 for U.S. Appl. No. 10/899,648, filed Jul. 26, 2004, seven pages.

U.S. Non Final Office Action dated Jun. 5, 2018 for U.S. Appl. No. 14/860,687, filed Sep. 21, 2015, eighteen pages.

U.S. Non Final Office Action dated Jun. 8, 2018 for U.S. Appl. No. 15/343,034, filed Nov. 3, 2016, thirteen pages.

U.S. Non Final Office Action dated Jun. 8, 2018 for U.S. Appl. No. 15/584,405, filed May 2, 2017, eight pages.

U.S. Non Final Office Action dated Jun. 9, 2011 for U.S. Appl. No. 11/830,323, filed Jul. 30, 2007, five pages.

U.S. Non Final Office Action dated Jun. 20, 2008 for U.S. Appl. No. 11/009,398, filed Dec. 10, 2004, fifteen pages

U.S. Non Final Office Action dated Jun. 23, 2010 for U.S. Appl. No. 11/009,965, filed Dec. 10, 2004, fifteen pages.

U.S. Non Final Office Action dated Jun. 27, 2014 for U.S. Appl. No. 13/415,561, filed Mar. 3, 2012, fourteen pages.

U.S. Non Final Office Action dated May 18, 2004 for U.S. Appl. No. 10/050,601, filed Jan. 15, 2002, eight pages.

U.S. Non Final Office Action dated May 25, 2018 for U.S. Appl. No. 15/343,038, filed Nov. 3, 2016, eleven pages.

U.S. Non Final Office Action dated Nov. 5, 2014 for U.S. Appl. No. 13/930,225, filed Jun. 28, 2013, six pages.

U.S. Non Final Office Action dated Nov. 23, 2009 for U.S. Appl. No. 11/969,974, filed Jan. 7, 2008, seven pages.

U.S. Non Final Office Action dated Oct. 5, 2016 for U.S. Appl. No. 15/247,419, filed Aug. 25, 2016, eight pages.

U.S. Non Final Office Action dated Oct. 7, 2011 for U.S. Appl. No. 11/964,330, filed Dec. 26, 2007; ten pages.

U.S. Non Final Office Action dated Oct. 23, 2013 for U.S. Appl. No. 13/415,561, filed Mar. 8, 2012, ten pages.

U.S. Non Final Office Action dated Sep. 6, 2016 for U.S. Appl. No. 14/873,842, filed Oct. 2, 2015, seven pages.

U.S. Non Final Office Action dated Sep. 12, 2014 for U.S. Appl. No. 14/154,177, filed Jan. 13, 2014, four pages.

U.S. Non Final Office Action dated Sep. 25, 2017 for U.S. Appl. No. 15/584,405, filed May 2, 2017, eight pages.

U.S. Non Final Office Action with Restriction Requirement dated Mar. 4, 2011 for U.S. Appl. No. 11/830,323, filed Jul. 30, 2007, nine pages.

U.S. Appl. No. 15/810,911, filed Nov. 13, 2017. (Not submitted herewith pursuant to the waiver of 37 C.F.R. § 1.98(a)(2)(iii) issued by the Office on Sep. 21, 2004).

U.S. Notice of Allowance dated Apr. 7, 2004 for U.S. Appl. No. 09/905,642, filed Jul. 13, 2001, six pages.

U.S. Notice of Allowance dated Aug. 6, 2015 for U.S. Appl. No. 13/853,656, filed Mar. 29, 2013, seven pages.

U.S. Notice of Allowance dated Aug. 26, 2004 for U.S. Appl. No. 10/050,601, filed Jan. 15, 2002, eight pages.

U.S. Notice of Allowance dated Dec. 10, 2012 for U.S. Appl. No. 11/964,330, filed Dec. 26, 2007, seven pages.

U.S. Notice of Allowance dated Dec. 30, 2016 for U.S. Appl. No. 14/873,842, filed Oct. 2, 2015, eleven pages.

U.S. Notice of Allowance dated Feb. 25, 2010 for U.S. Appl. No. 11/969,974, filed Jan. 7, 2008, four pages.

U.S. Notice of Allowance dated Jan. 2, 2008 for U.S. Appl. No. 10/899,648, filed Jul. 26, 2004, three pages.

U.S. Notice of Allowance dated Jul. 10, 2017 for U.S. Appl. No. 15/247,419, filed Aug. 25, 2016, eight pages.

U.S. Notice of Allowance dated Jun. 25, 2015 for U.S. Appl. No. 12/933,512, filed Nov. 24, 2010 fourteen pages.

U.S. Notice of Allowability dated Mar. 10, 2005 for U.S. Appl. No. 10/050,601, filed Jan. 15, 2002, five pages.

U.S. Notice of Allowance dated Mar. 22, 2013 for U.S. Appl. No. 11/964,330, filed Dec. 26, 2007, eight pages.

U.S. Notice of Allowance dated Mar. 28, 2016 for U.S. Appl. No. 13/853,656, filed Mar. 29, 2013, eight pages.

U.S. Notice of Allowance dated May 18, 2015 for U.S. Appl. No. 13/930,225, filed Jun. 28, 2013, nine pages.

U.S. Notice of Allowance dated Nov. 23, 2015 for U.S. Appl. No. 13/853,656, filed Mar. 29, 2013, seven pages.

U.S. Notice of Allowance dated Oct. 5, 2007 for U.S. Appl. No. 10/899,648, filed Jul. 26, 2004, six pages.

U.S. Notice of Allowance dated Oct. 10, 2014 for U.S. Appl. No. 12/761,462, filed Apr. 16, 2010, ten pages.

U.S. Notice of Allowance dated Sep. 10, 2013 for U.S. Appl. No. 11/412,715, filed Apr. 26, 2006, eight pages.

U.S. Notice of Allowance dated Sep. 14, 2012 for U.S. Appl. No. 11/830,323, filed Jul. 30, 2007, eight pages.

Written Opinion of the International Searching Authority dated Aug. 3, 2006 for International Patent Application No. PCT/CA2006/000669, filed on Apr. 27, 2006, eight pages.

Written Opinion of the International Searching Authority dated Dec. 7, 2007 for International Patent Application No. PCT/CA2007/001335, filed Jul. 30, 2007, four pages.

Australian Notice of Allowance dated Jun. 26, 2019 for Patent Application No. 2016351730 filed on Nov. 10, 2016, three pages.

Brazilian Office Action dated Aug. 5, 2019, for Patent Application No. BR1120130229977, filed Mar. 8, 2012, four pages (including English translation).

Canadian Office Action dated Nov. 5, 2019, for Patent Application No. 3027592, filed on Jun. 14, 2017, four pages.

Chinese Notice of Allowance dated Jan. 13, 2020, for Patent Application No. 2017-10785223.7, filed Mar. 8, 2012, six pages (including English translation).

European Extended Search Report dated May 7, 2019, for Patent Application No. 16863277.6, filed Nov. 10, 2016, seven pages.

European Extended Search Report dated Oct. 16, 2019, for Patent Application No. 17743524.5, filed Jan. 26, 2017, four pages.

European Search Report dated Feb. 18, 2019 for EP Patent Application No. 18178620.3 filed on Jun. 19, 2018, eight pages.

Japanese Office Action dated Jan. 10, 2020, for Japanese Patent Application No. 2018-516161, filed Nov. 10, 2016, five pages (including English translation).

Japanese Office Action dated Jul. 12, 2019, for Patent Application No. 2018-516161, filed Nov. 10, 2016, twenty-one pages (including English translation).

Sensitization (photography), definition from Wikipedia, original language German, 6 pages (Machine Translation).

U.S. Final Office Action dated Jul. 25, 2019 for U.S. Appl. No. 15/416,876, filed Jan. 26, 2017, thirteen pages.

U.S. Non Final Office Action dated Aug. 2, 2019 for U.S. Appl. No. 15/623,100, filed Jun. 14, 2017, twelve pages.

U.S. Non Final Office Action dated Aug. 21, 2019 for U.S. Appl. No. 15/584,405, filed May 2, 2017, six pages.

U.S. Non Final Office Action dated Aug. 23, 2019 for U.S. Appl. No. 15/343,038, filed Nov. 3, 2016, fourteen pages.

U.S. Non-Final Office Action dated Jan. 16, 2020, for U.S. Appl. No. 15/416,876, filed Jan. 26, 2017, thirteen pages.

U.S. Non-Final Office Action dated Aug. 23, 2019 for U.S. Appl. No. 14/860,687, filed Sep. 21, 2015, fourteen pages.

U.S. Non-Final Office Action dated Aug. 23, 2019 for U.S. Appl. No. 15/343,034, filed Nov. 3, 2016, eighteen pages.

U.S. Appl. No. 16/441,493, filed Jun. 14, 2019. (the U.S. Patent Application is not submitted herewith pursuant to the waiver of 37 C.F.R. § 1.98(a)(2)(iii) issued by the Office on Sep. 21, 2004.)

* cited by examiner

Primary Examiner — Ian Simmons
Assistant Examiner — Yolanda Robinson
 (74) *Attorney, Agent, or Firm* — Morrison & Foerster LLP

(57) **CLAIM**

The ornamental design for an illumination and imaging device, as shown and described.

DESCRIPTION

FIG. 1 is a perspective view of a first embodiment of an illumination and imaging device, in accordance with our new design;

FIG. 2 is a front view thereof;
FIG. 3 is a rear view thereof;
FIG. 4 is a left-side view thereof;
FIG. 5 is a right-side view thereof;
FIG. 6 is a top view thereof;
FIG. 7 is a bottom view thereof;
FIG. 8 is a perspective view of a second embodiment of an illumination and imaging device, in accordance with our new design;
FIG. 9 is a front view thereof;
FIG. 10 is a rear view thereof;
FIG. 11 is a left-side view thereof;
FIG. 12 is a right-side view thereof;
FIG. 13 is a top view thereof; and,
FIG. 14 is a bottom view thereof.

The broken lines shown in the device for illumination and imaging of a target are for the purpose of illustrating portions of the article that form no part of the claimed design.

1 Claim, 14 Drawing Sheets

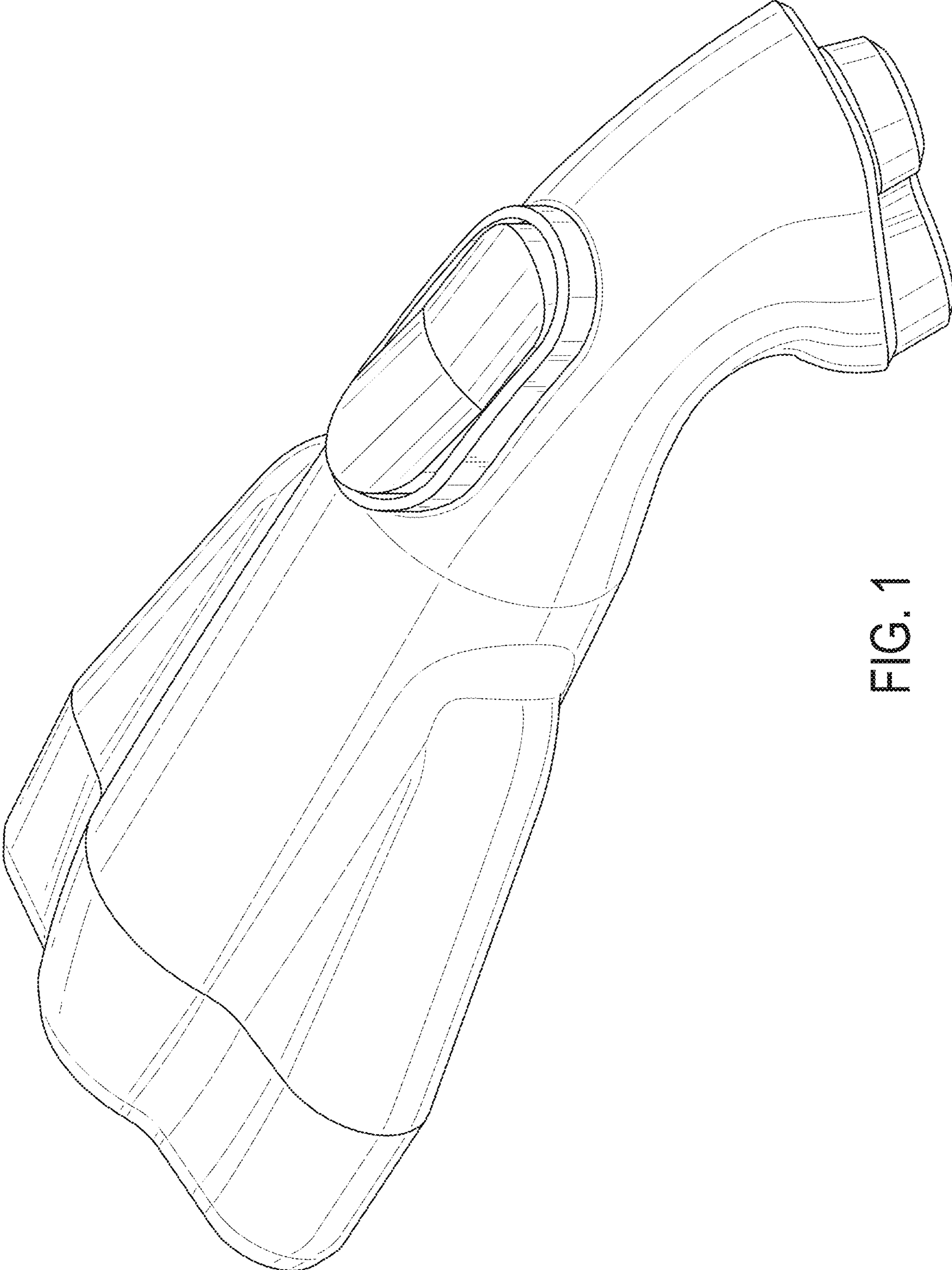

FIG. 1

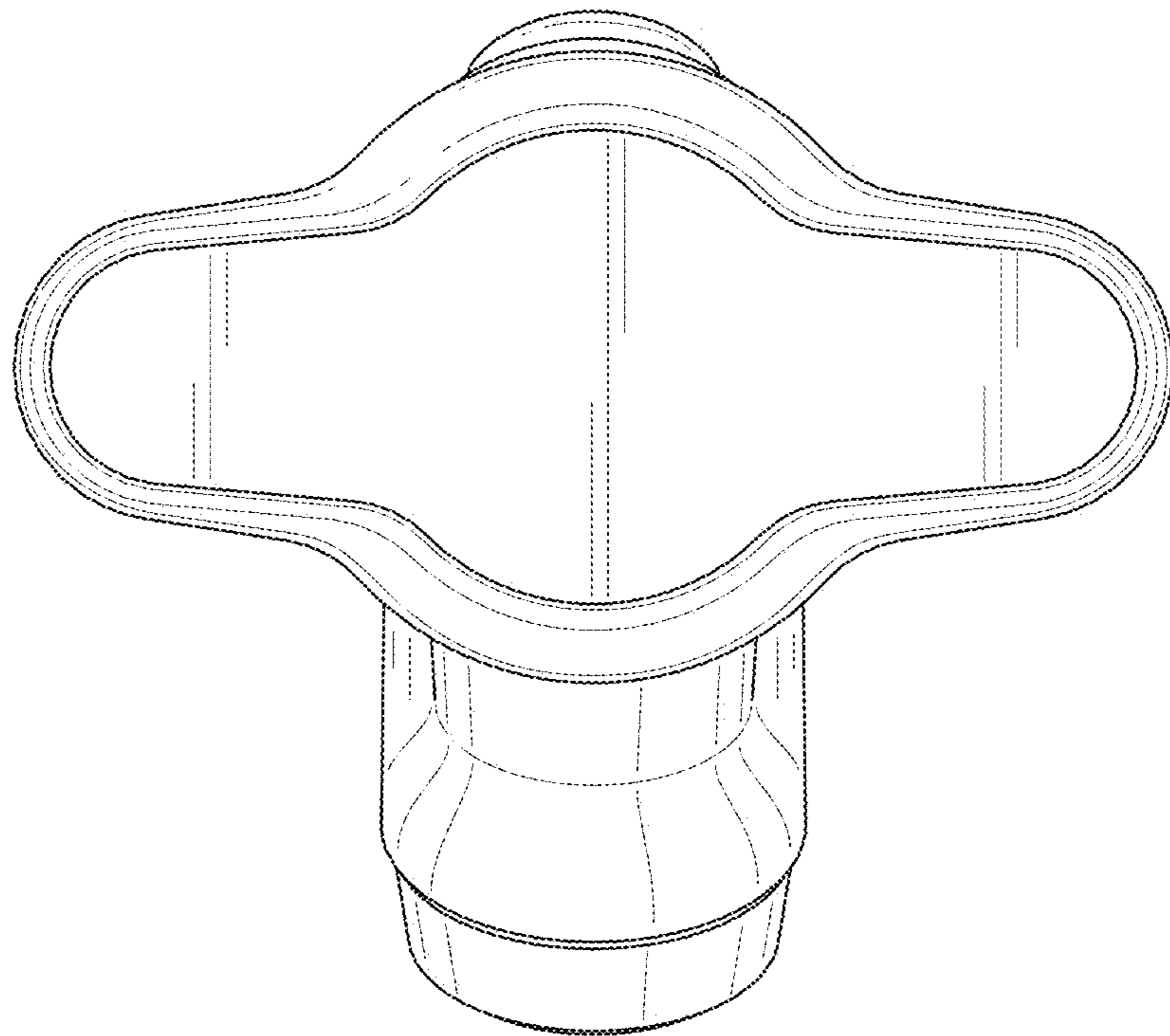

FIG. 2

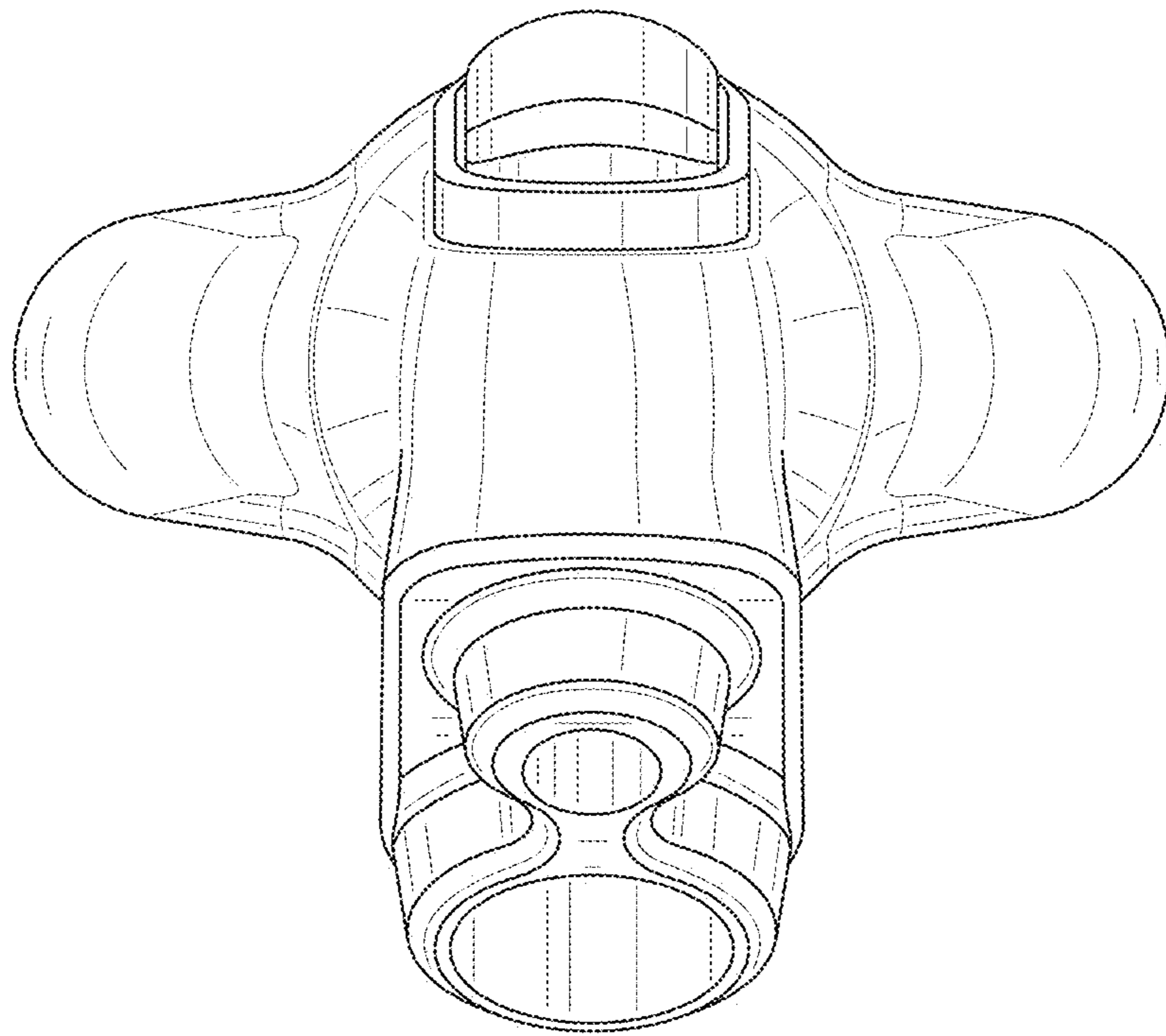

FIG. 3

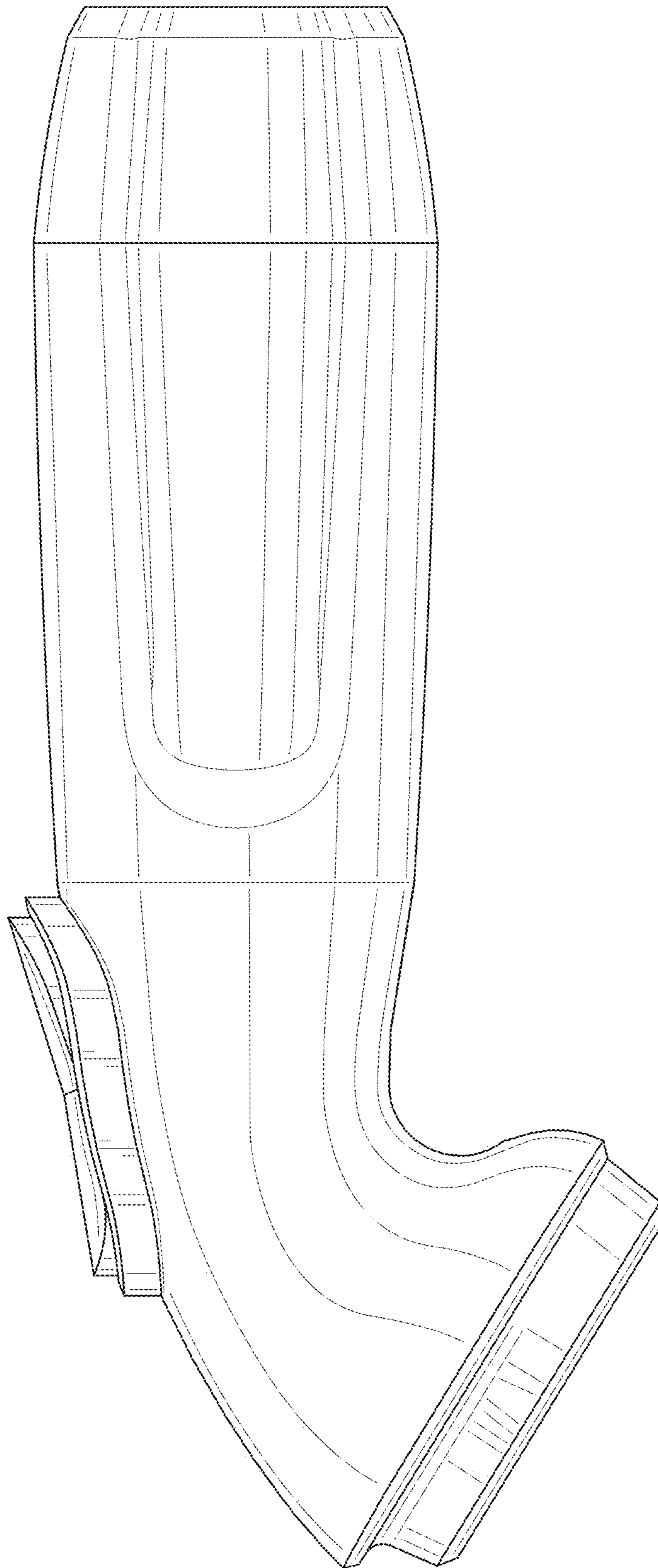

FIG. 4

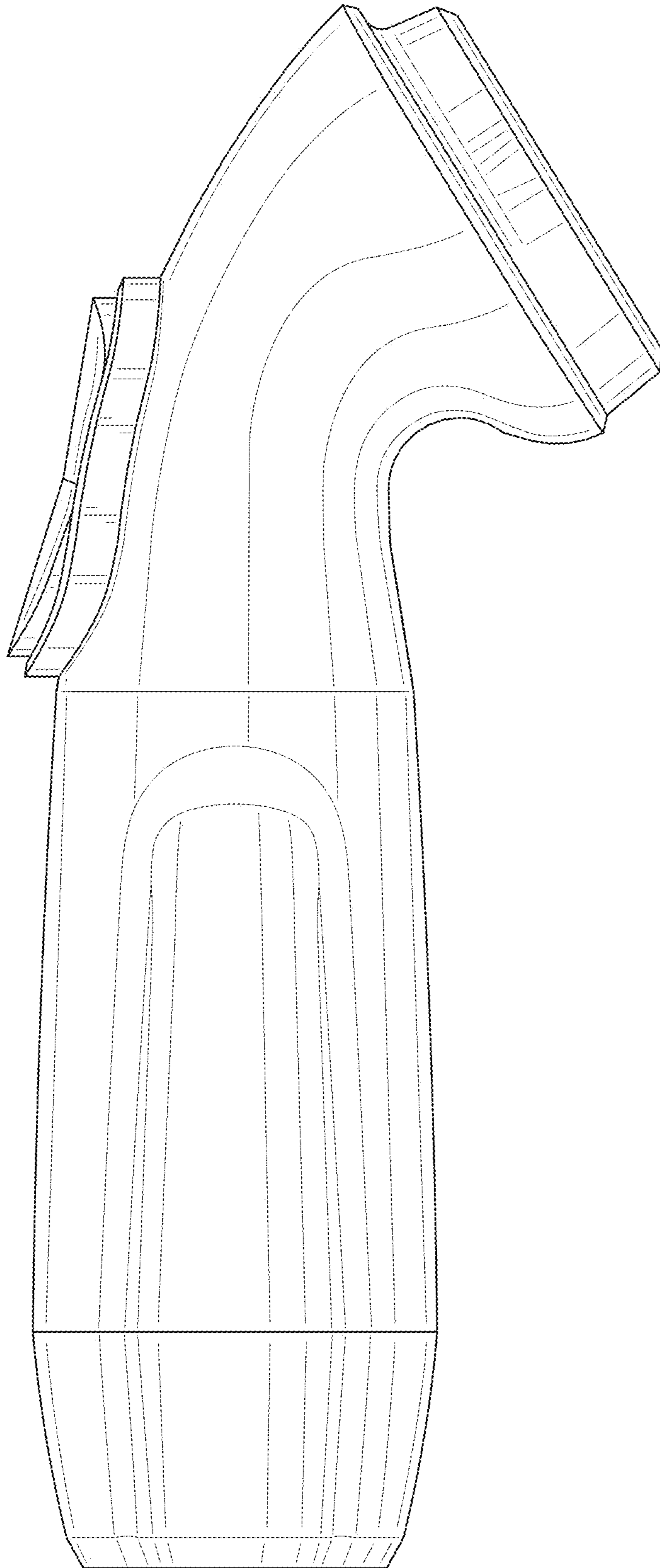

FIG. 5

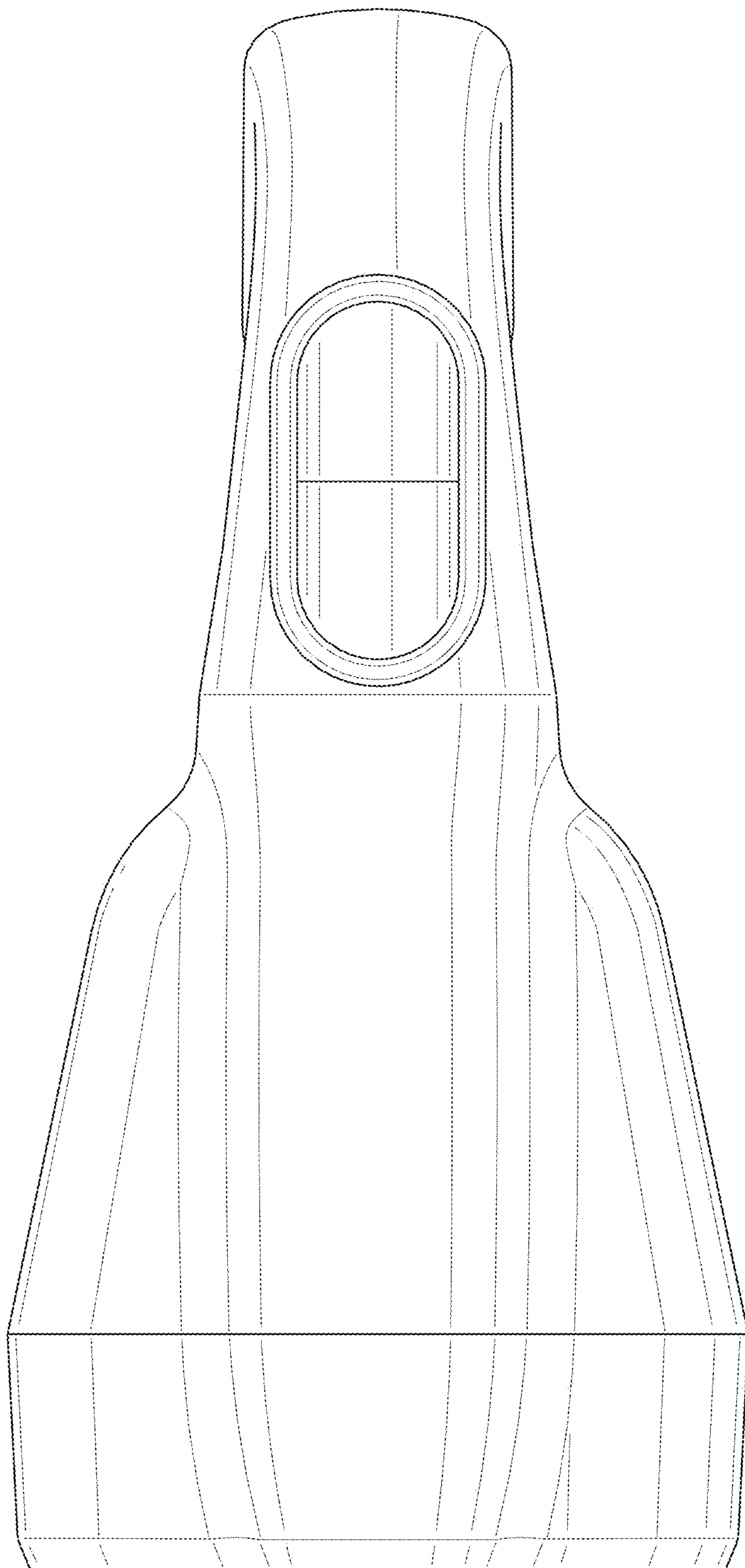

FIG. 6

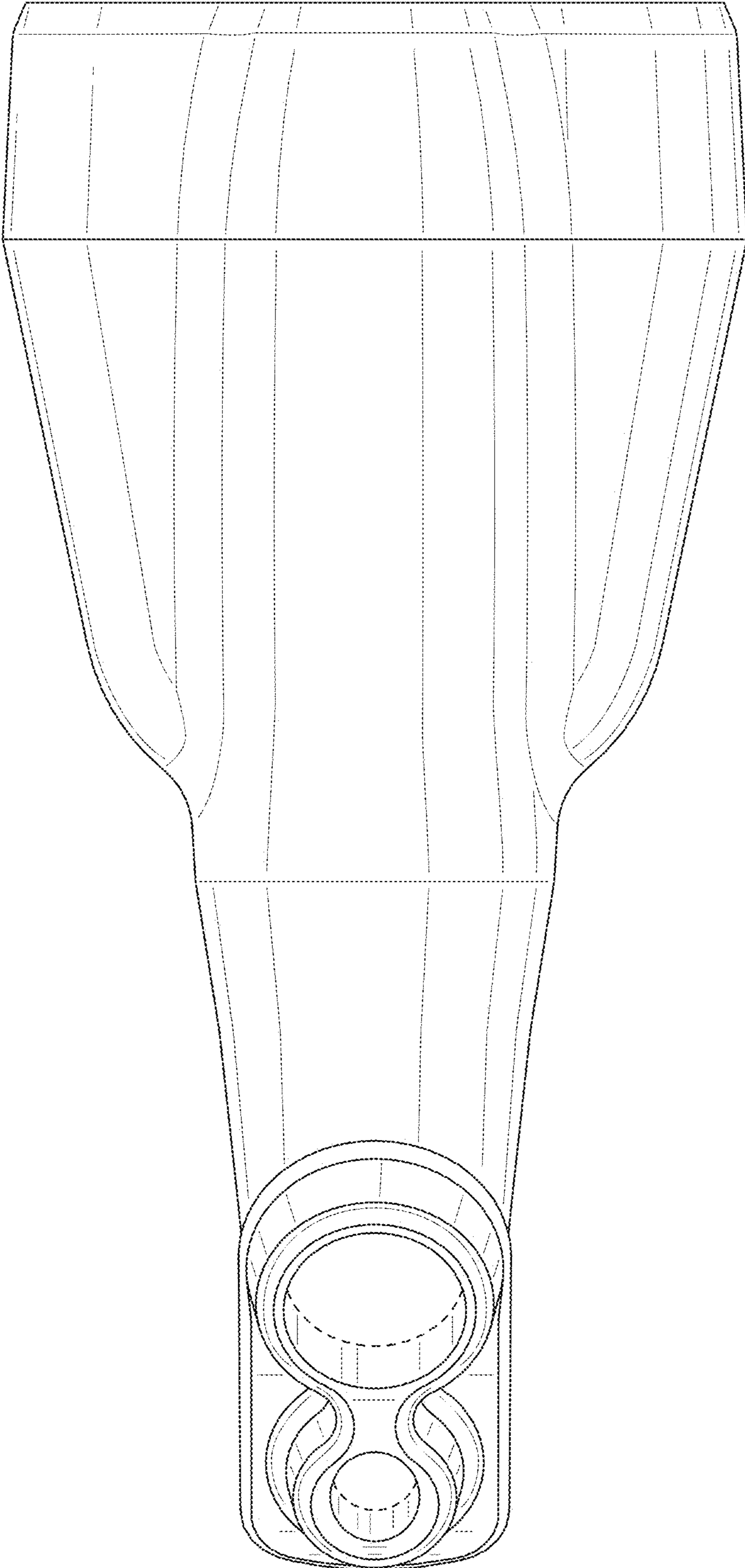

FIG. 7

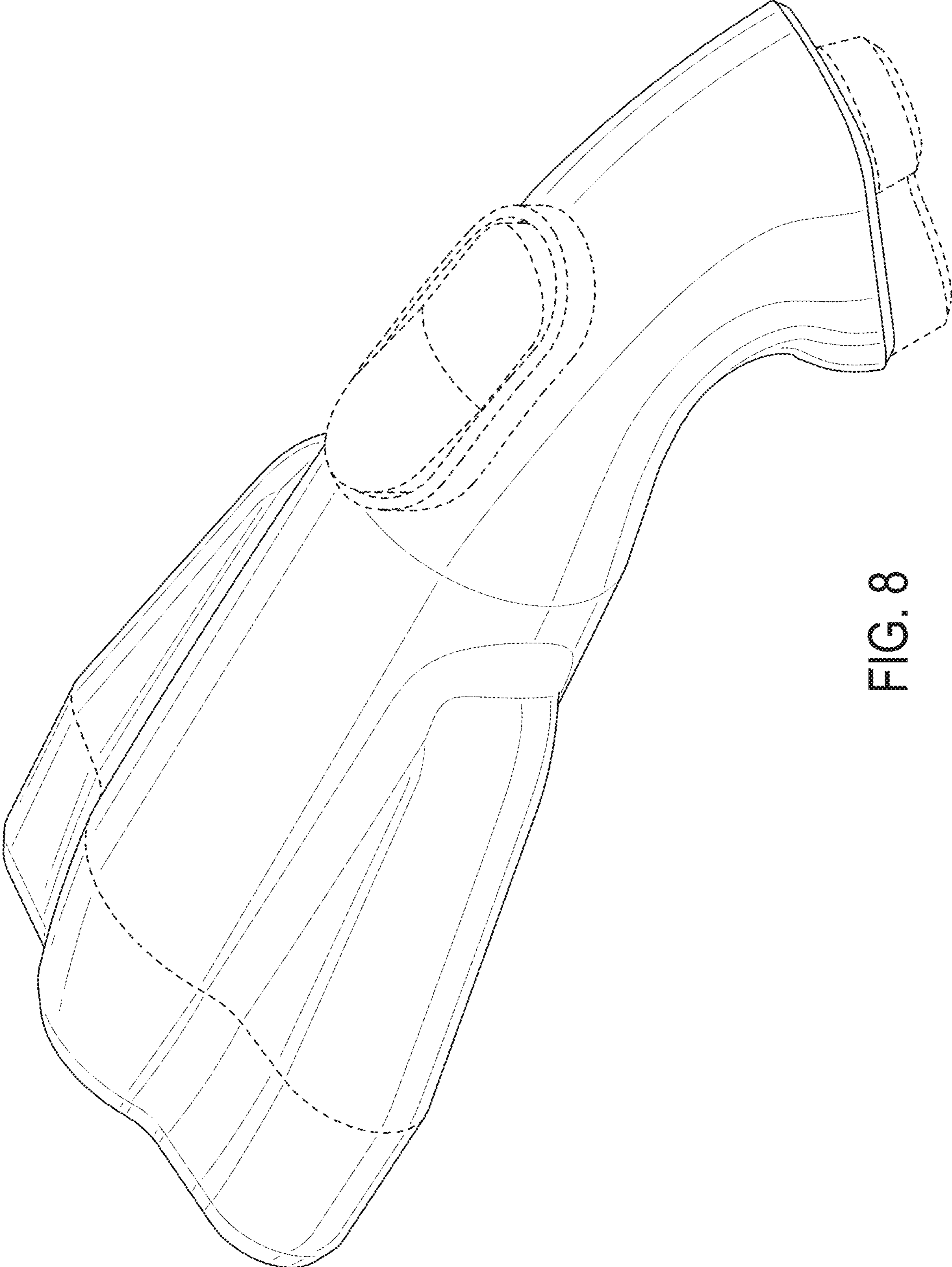

FIG. 8

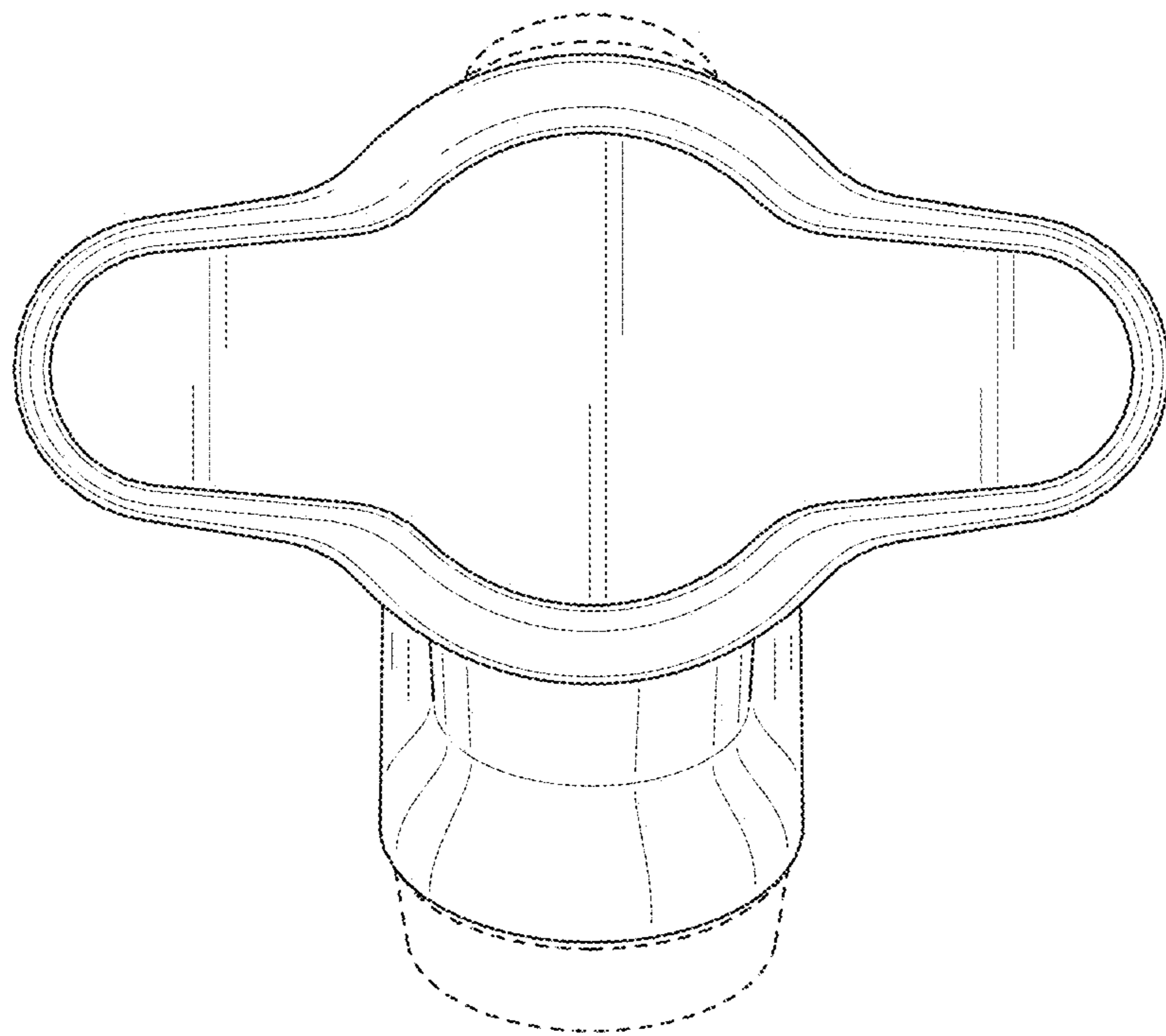

FIG. 9

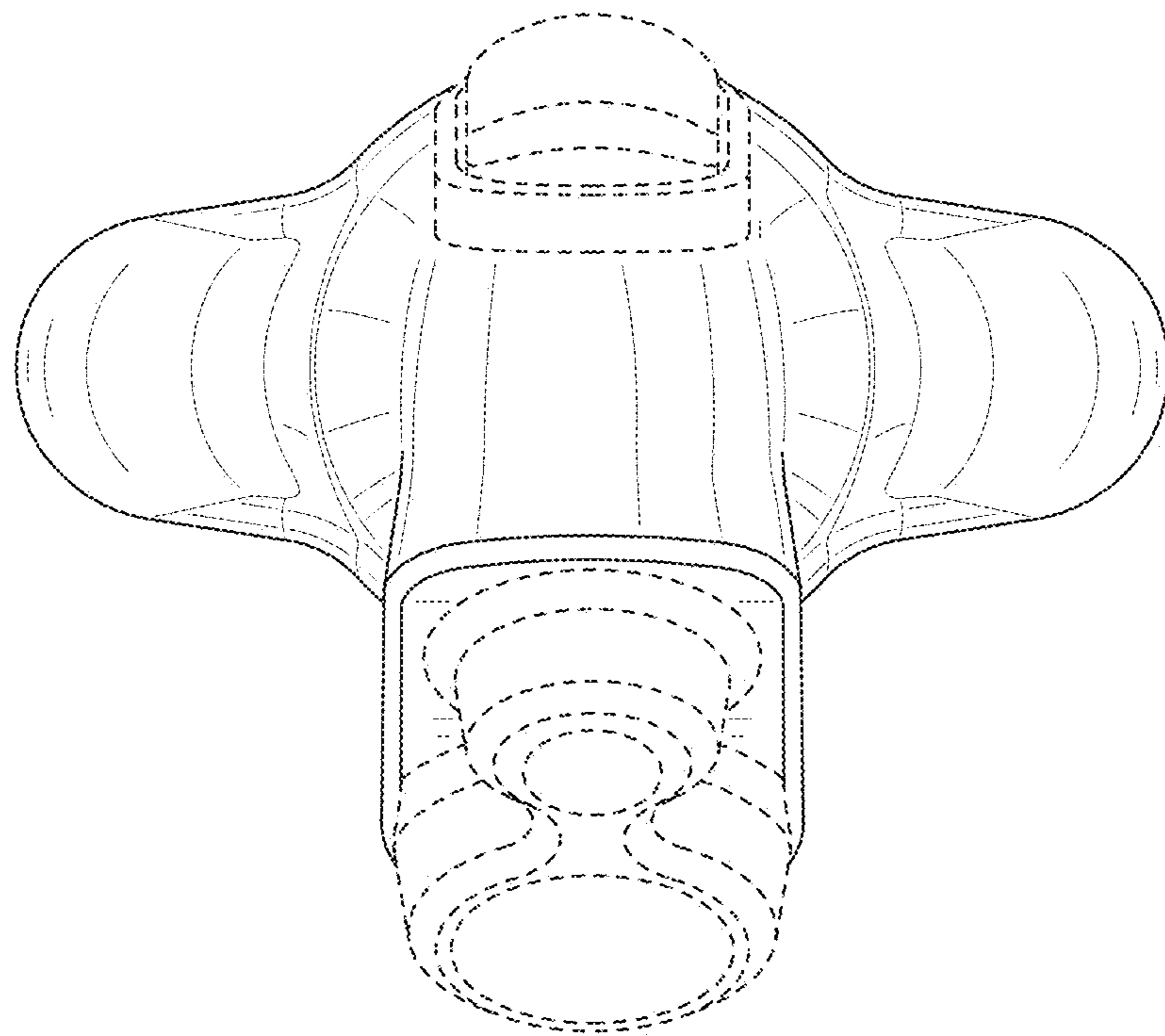

FIG. 10

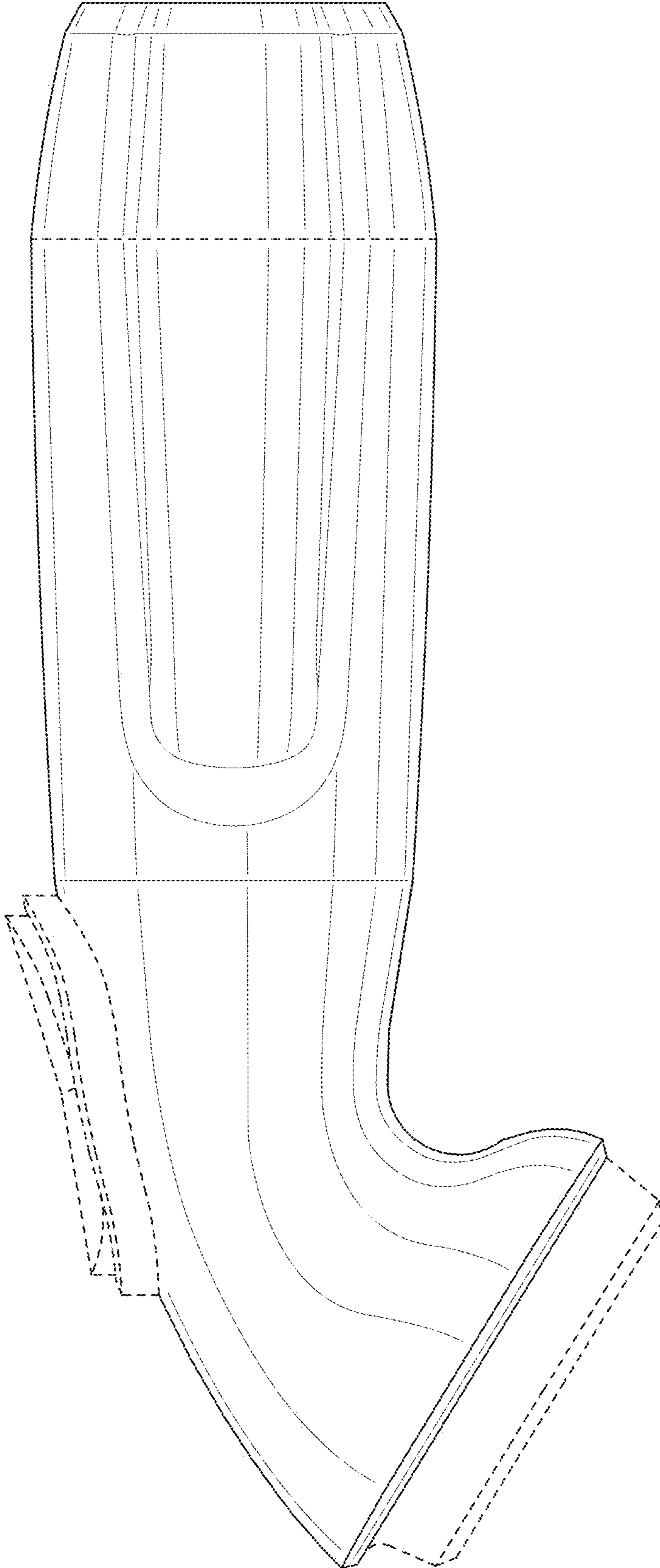

FIG. 11

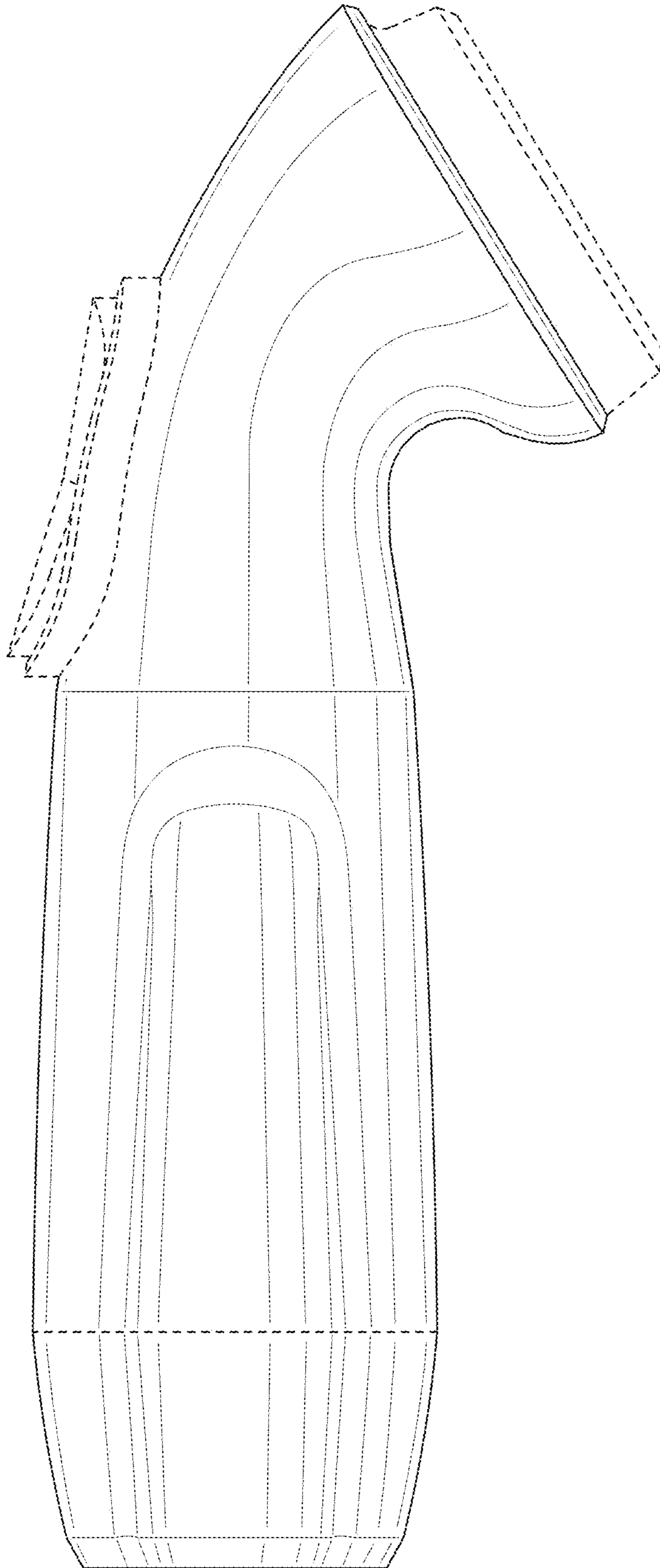

FIG. 12

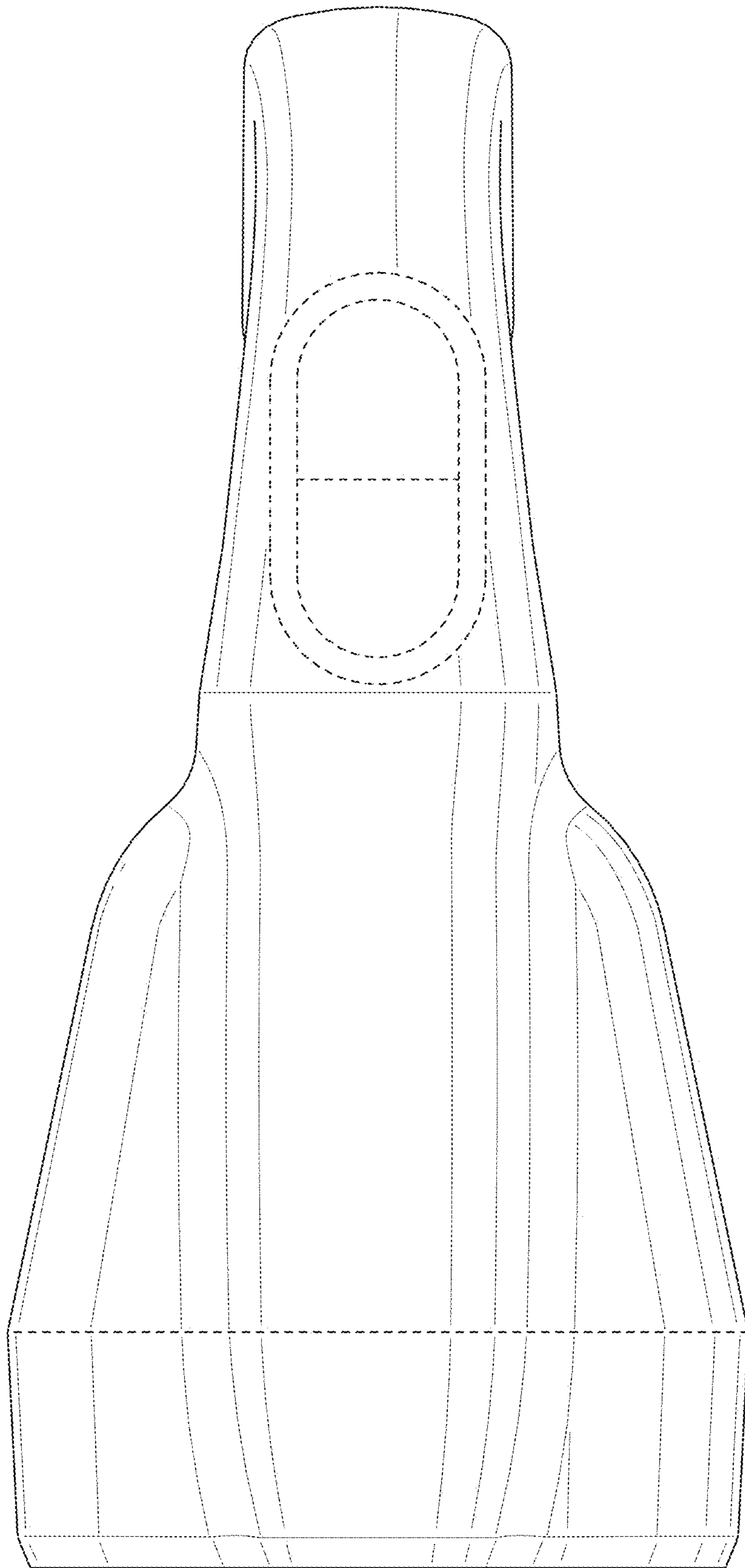

FIG. 13

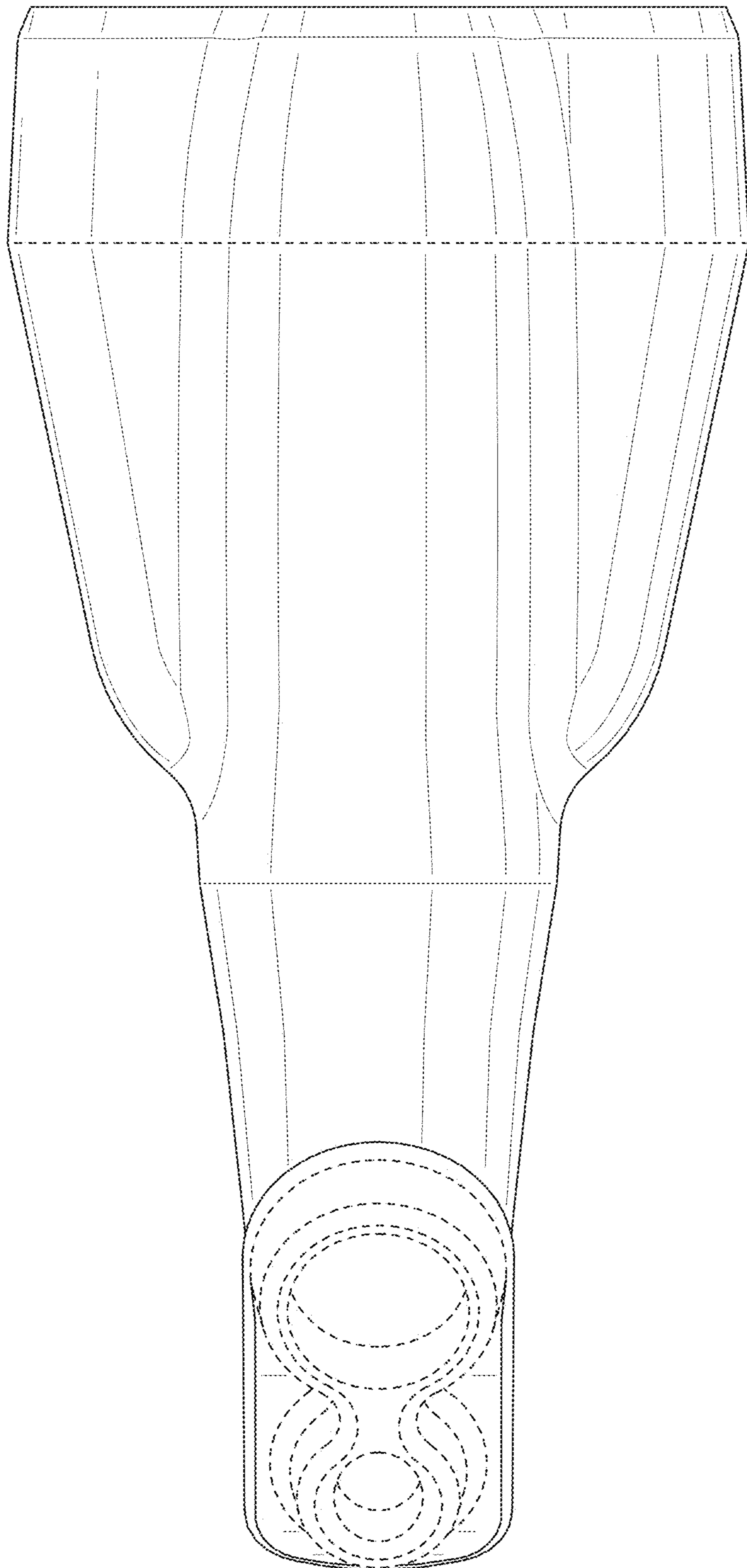

FIG. 14