



US00D916290S

(12) **United States Design Patent** (10) **Patent No.:** **US D916,290 S**
Loria (45) **Date of Patent:** **** Apr. 13, 2021**

(54) **HAIR IMPLANT**

(71) Applicant: **Loria Products LLC**, Miami, FL (US)
(72) Inventor: **Victor Loria**, Miami, FL (US)
(73) Assignee: **LORIA PRODUCTS LLC**, Miami, FL (US)

(**) Term: **15 Years**

(21) Appl. No.: **29/682,443**

(22) Filed: **Mar. 5, 2019**

(51) **LOC (13) Cl.** **24-03**

(52) **U.S. Cl.**
USPC **D24/155**

(58) **Field of Classification Search**
USPC D24/107, 133, 137, 138, 141, 147,
D24/158-161, 164, 165, 167, 170,
(Continued)

(56) **References Cited**

U.S. PATENT DOCUMENTS

3,003,155 A * 10/1961 Mielzynski A61F 2/10
623/15.11

3,596,292 A 8/1971 Erb et al.
(Continued)

FOREIGN PATENT DOCUMENTS

WO 2019027864 A1 2/2019

OTHER PUBLICATIONS

International Search Report for PCT Application No. PCT/US2018/
044298 dated Oct. 1, 2018.

(Continued)

Primary Examiner — T Chase Nelson

Assistant Examiner — Kelly L Gross

(74) *Attorney, Agent, or Firm* — Caesar Rivise, PC

(57) **CLAIM**

The ornamental design for a hair implant, as shown and described.

DESCRIPTION

FIG. 1 is a top, isometric view of a hair implant showing my new design;
FIG. 2 is a bottom, isometric view of the hair implant of FIG. 1;
FIG. 3 is a front, elevation view of the hair implant of FIG. 1;
FIG. 4 is a rear, elevation view of the hair implant of FIG. 1;
FIG. 5 is a right side elevation view of the hair implant of FIG. 1;
FIG. 6 is a left side elevation view of the hair implant of FIG. 1;
FIG. 7 is a top, plan view of the hair implant of FIG. 1;
FIG. 8 is a bottom plan view of the hair implant of FIG. 1;
FIG. 9 is a top, isometric view of a hair implant showing a second embodiment of my new design;
FIG. 10 is a bottom, isometric view of the hair implant of FIG. 9;
FIG. 11 is a front, elevation view of the hair implant of FIG. 9;
FIG. 12 is a rear, elevation view of the hair implant of FIG. 9;
FIG. 13 is a right side elevation view of the hair implant of FIG. 9;
FIG. 14 is a left side elevation view of the hair implant of FIG. 9;
FIG. 15 is a top, plan view of the hair implant of FIG. 9; and,
FIG. 16 is a bottom plan view of the hair implant of FIG. 9.
The features shown in broken lines in the drawing depict portions of the design that form no part of the claimed design.

1 Claim, 8 Drawing Sheets

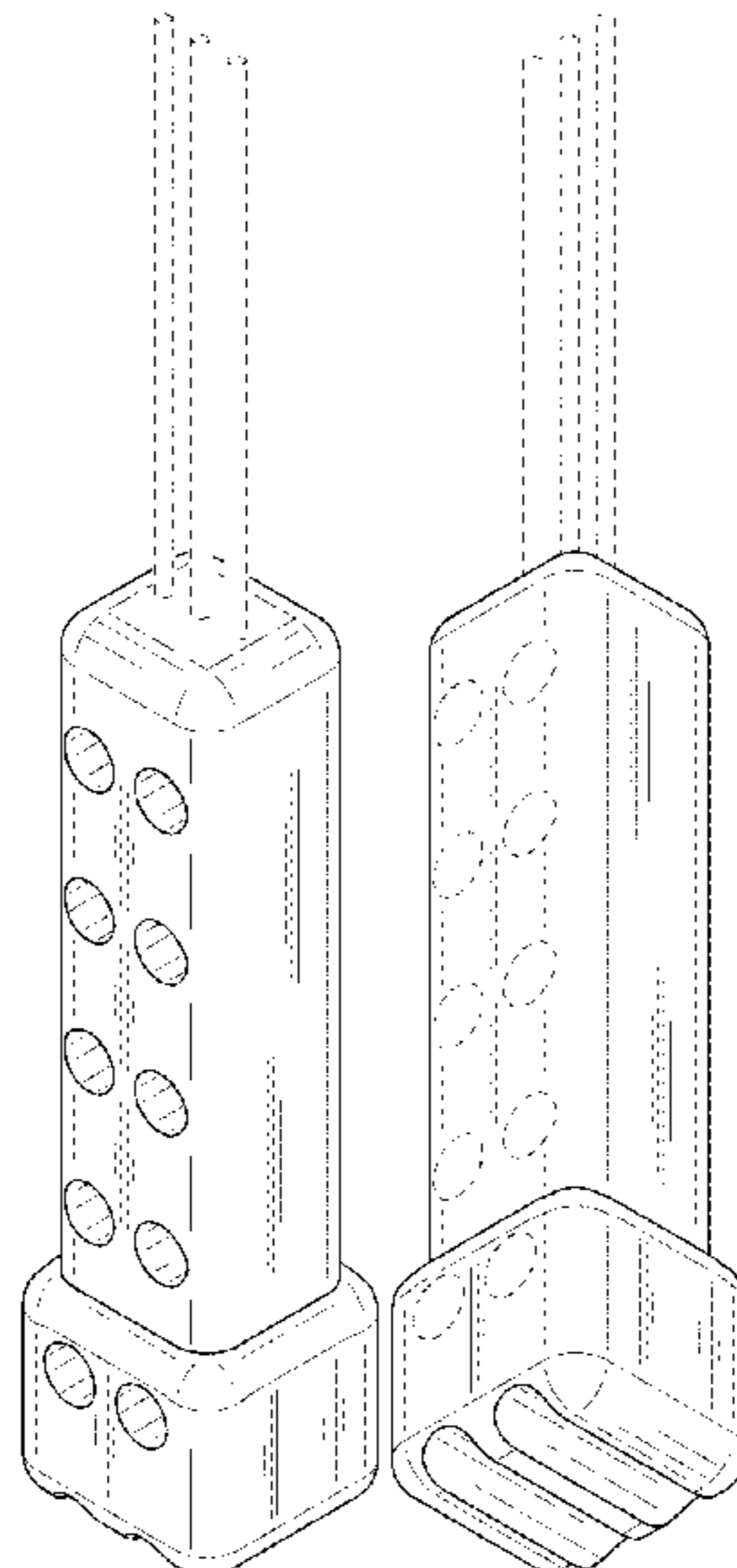

(58) **Field of Classification Search**

USPC D24/185-187, 130, 112, 113, 146, 200,
 D24/155, 119, 126, 156, 157; D10/57,
 D10/60, 78, 80; D6/709; D28/7; D8/80,
 D8/83, 94; D4/127, 130, 132, 135
 CPC A61B 17/0469; A61B 17/0482; A61B
 2017/2927; A61B 8/0437; A61B 8/0883;
 A61B 8/4405; A61B 8/4427; A61B
 8/445; A61B 17/0642; A61B 17/0682;
 A61B 17/0644; A61B 17/03; A61N 1/05;
 F16B 15/06

See application file for complete search history.

(56) **References Cited**

U.S. PATENT DOCUMENTS

3,699,969 A 10/1972 Allen
 D251,184 S * 2/1979 Volk D10/103
 D276,594 S * 12/1984 Fahey D9/420
 D290,820 S * 7/1987 Slovak D10/103
 5,061,284 A 10/1991 Laghi
 5,137,533 A * 8/1992 Giampapa A61F 2/10
 623/15.11
 D339,438 S * 9/1993 Moran D34/1
 5,485,649 A * 1/1996 Miceli A46B 9/10
 15/144.4
 D392,871 S * 3/1998 Chang D8/107
 5,767,152 A 6/1998 Nielsen et al.
 5,800,545 A 9/1998 Yamada et al.
 D399,151 S * 10/1998 Fisher D10/78
 D400,455 S * 11/1998 Fisher D10/78
 D405,335 S * 2/1999 Lin D8/82
 D434,223 S * 11/2000 Dombrowski D3/272
 D472,827 S * 4/2003 Harju D10/78
 D478,267 S * 8/2003 Chen D8/107
 D481,963 S * 11/2003 Onuma D10/78
 D519,031 S * 4/2006 Snyder D9/522
 D523,557 S * 6/2006 Jones D24/155
 D546,176 S * 7/2007 Degn D9/423
 D584,640 S * 1/2009 Castelnuovo-Tedesco D9/694
 D589,479 S * 3/2009 Pozin D14/127
 D590,788 S * 4/2009 Pozin D14/127
 D604,413 S * 11/2009 Ikeya D24/156
 7,621,958 B2 * 11/2009 Zdeblick A61B 17/025
 623/17.16
 D606,833 S * 12/2009 Robinson D8/86
 D621,938 S * 8/2010 Petersen D24/140
 D622,853 S * 8/2010 Raven, III D24/155
 D627,468 S * 11/2010 Richter D24/155
 D628,917 S * 12/2010 Tian D10/78
 D634,421 S * 3/2011 El-Gad D24/113
 D635,271 S * 3/2011 Azar D24/200
 D640,470 S * 6/2011 Spagnuolo D4/114
 D641,475 S * 7/2011 Graham D24/155
 D641,876 S * 7/2011 Graham D24/155
 D643,121 S * 8/2011 Milford D24/155
 D649,633 S * 11/2011 Claypool D24/133
 D655,010 S * 2/2012 Wenk D24/155
 D657,873 S * 4/2012 Khalil D24/146
 8,177,557 B2 * 5/2012 Delmonico A61C 8/0048
 433/180
 D679,391 S * 4/2013 Chinowsky D24/127
 D681,292 S * 4/2013 Fujiwara D32/35
 D697,036 S * 1/2014 Kay D13/168
 D718,106 S * 11/2014 Lauzet D8/33
 D719,739 S * 12/2014 Brescia D4/121
 D721,435 S * 1/2015 Patterson D24/140
 D731,056 S * 6/2015 Tsai D24/146
 D733,599 S * 7/2015 Yokino D10/81
 D733,882 S * 7/2015 Fregoso D24/152
 D735,404 S * 7/2015 Gourmet D28/7
 D740,940 S * 10/2015 Fregoso D24/152
 D747,228 S * 1/2016 Fiedler D10/104.1
 D754,346 S * 4/2016 Pimenta D24/155
 D761,427 S * 7/2016 Patterson D24/140

D771,812 S * 11/2016 Shayle D24/146
 D771,956 S * 11/2016 Hauger D4/114
 9,492,196 B2 11/2016 Keren et al.
 D774,310 S * 12/2016 Hauger D4/114
 9,510,940 B2 * 12/2016 Chen A61F 2/186
 D790,615 S * 6/2017 Nowak D15/148
 D791,936 S * 7/2017 Davis D24/127
 D796,354 S * 9/2017 Chan D10/56
 D799,743 S * 10/2017 Qiu D27/101
 D800,566 S * 10/2017 Wieland D9/529
 D801,523 S * 10/2017 Khouri D24/130
 D801,622 S * 11/2017 Koo D1/120
 D809,656 S * 2/2018 Lau D24/129
 D813,001 S * 3/2018 Whitcomb D8/14
 D813,375 S * 3/2018 Dillworth D24/110
 D817,279 S * 5/2018 Lin D13/123
 D819,337 S * 6/2018 Yuan D4/101
 D821,100 S * 6/2018 Sanghi D4/135
 9,993,334 B1 6/2018 Loria
 D824,177 S * 7/2018 Salm D4/138
 D829,446 S * 10/2018 Katsuma D4/135
 D831,199 S * 10/2018 Holton D24/127
 10,105,212 B1 10/2018 Loria
 D833,064 S * 11/2018 Verleur D27/172
 D834,246 S * 11/2018 Qiu D27/162
 D834,369 S * 11/2018 Gettig D7/401.2
 D835,841 S * 12/2018 Xu D27/167
 D837,297 S * 1/2019 Muroi D19/117
 D838,494 S * 1/2019 Fischer D4/133
 10,182,807 B2 * 1/2019 Bridgeman A61B 17/0401
 D851,760 S * 6/2019 Lee D24/130
 D856,588 S * 8/2019 French-Artis D28/76
 D857,333 S * 8/2019 Axelrod D1/199
 D857,469 S * 8/2019 Whitcomb D8/14
 D858,282 S * 9/2019 Han D9/436
 D858,637 S * 9/2019 Ballot D19/170
 D858,770 S * 9/2019 Lintula D24/155
 D860,450 S * 9/2019 Asfora D24/140
 D865,072 S * 10/2019 Gambucci D21/468
 D867,764 S * 11/2019 Stubbs D4/115
 D867,840 S * 11/2019 Macor D8/27
 D869,656 S * 12/2019 Adams D24/145
 D869,849 S * 12/2019 Chen D4/100
 D870,282 S * 12/2019 Adams D24/145
 D870,283 S * 12/2019 Adams D24/145
 D870,889 S * 12/2019 Miller D24/155
 D873,031 S * 1/2020 Martensson D4/138
 D873,518 S * 1/2020 Chavez D32/50
 D874,650 S * 2/2020 Horan D24/155
 D876,628 S * 2/2020 Siman D24/155
 D877,906 S * 3/2020 Linder D24/155
 10,588,525 B2 * 3/2020 Someya A61B 5/0492
 D882,070 S * 4/2020 Inoh D24/112
 D882,085 S * 4/2020 Sweeney D24/146
 D882,087 S * 4/2020 Sarig D24/152
 D882,274 S * 4/2020 Han D4/135
 D884,176 S * 5/2020 Jury D24/155
 D884,177 S * 5/2020 Orion D24/155
 D885,665 S * 5/2020 Richter D28/20
 10,646,217 B2 * 5/2020 Pisarnwongs A61B 17/0483
 D887,125 S * 6/2020 Schubert D3/28
 D887,126 S * 6/2020 Schubert D3/28
 D888,240 S * 6/2020 Parcon D24/146
 D888,957 S * 6/2020 Pikkula D24/152
 D890,987 S * 7/2020 Lorenz D28/7
 D891,117 S * 7/2020 Theodosis D4/121
 D893,198 S * 8/2020 Kaicker D4/135
 D896,385 S * 9/2020 Lim D24/155
 D898,531 S * 10/2020 Kerr D8/21
 D901,178 S * 11/2020 Kim D3/298
 D904,616 S * 12/2020 DaCosta D24/155
 2003/0195625 A1 10/2003 Garcia Castro et al.
 2005/0191748 A1 9/2005 Barrows
 2005/0267506 A1 12/2005 Harris
 2007/0067033 A1 3/2007 Bonati
 2007/0282364 A1 12/2007 Haber
 2010/0305699 A1 12/2010 Kim
 2012/0245612 A1 9/2012 Keren et al.
 2019/0117378 A1 * 4/2019 Loria A41G 5/0053

(56)

References Cited

U.S. PATENT DOCUMENTS

2019/0160289 A1* 5/2019 Kluger A61N 1/37205
 2019/0380827 A1* 12/2019 Loria A61F 2/10
 2020/0155300 A1* 5/2020 Bae A61F 2/0095

OTHER PUBLICATIONS

Ahdout et al. (2012). Weft hair extensions causing a distinctive horseshoe pattern of traction alopecia. *Journal of the American Academy of Dermatology*, 67(6), e294-e295.

Aktas et al. (2016). Could Topical Minoxidil Cause Non-Arteritic Anterior Ischemic Optic Neuropathy?. *Journal of clinical and diagnostic research: JCDR*, 10(8), WD01: 1-2.

Avitzur, O. (2013). The dangers of hair extensions: The beauty trend can cause headaches, baldness, and allergic reactions. *Consumer Reports*. Retrieved on Aug. 7, 2017 from <https://www.consumerreports.org/cro/2013/02/the-dangers-of-hair-extensions/index.htm>.

Avram et al. (2014). Side-effects from follicular unit extraction in hair transplantation. *Journal of cutaneous and aesthetic surgery*, 7(3), 177-179.

Barrera, A. (2005). Reconstructive hair transplantation of the face and scalp. In *Seminars in Plastic Surgery* 19(2): pp. 159-166.

Barrese et al. (2016). Scanning electron microscopy of chronically implanted intracortical microelectrode arrays in non-human primates. *Journal of neural engineering*, 13(2), 026003: 1-44.

Bascom, J. (1983). Pilonidal disease: long-term results of follicle removal. *Diseases of the colon & rectum*, 26(12), 800-807.

Benedetto et al. (2005). Pilonidal sinus disease treated by depilation using an 800 nm diode laser and review of the literature. *Dermatologic surgery*, 31(5), 587-591.

Bernard, B. A. (2016). Advances in understanding hair growth. *F1000Research*, 5: 1-8.

Bernstein, R. (2009). Psychological Aspects of Balding. Bernstein Medical Center for Hair Restoration. Retrieved on Aug. 4, 2017 from <https://www.bernsteinmedical.com/hair-loss/basics/psychology-of-balding/>.

Biofibre (2015). Hair Implant Safety. Biofibre: High Technology Hair Implant System. Retrieved on Aug. 7, 2017 from <http://www.biofibre.com/en/hair-implants/safety/>.

Biofibre (2015). Results. Biofibre: High Technology Hair Implant System. Retrieved on Aug. 7, 2017 from <http://www.biofibre.com/en/results/>.

Bryers et al. (2012). Engineering biomaterials to integrate and heal: the biocompatibility paradigm shifts. *Biotechnology and bioengineering*, 109(8), 1898-1911.

Cash, T. F. (1992). The psychological effects of androgenetic alopecia in men. *Journal of the American Academy of Dermatology*, 26(6), 926-931.

Chavoïn et al. (2016). Correction of congenital malformations by custom-made silicone implants: Contribution of computer-aided design. Experience of 611 cases. In *Annales de chirurgie plastique et esthétique*, vol. 61, No. 5, pp. 694-702.

Chellini et al. (2015). Generalized hypertrichosis induced by topical Minoxidil in an adult woman. *International Journal of trichology*, 7(4), 182-183.

Cochrane Database of Systematic Reviews: Plain Language Summaries (2008). Treatments for alopecia areata, alopecia totalis, and alopecia universalis. Plain Language Summary of Delamere (2008). Interventions for alopecia areata. The Cochrane Library. Art. No. CD004413. p. 1.

Cochrane Database of Systematic Reviews: Plain Language Summaries (2016). Treatments for female pattern hair loss. Plain Language Summary of van Zuuren et al. (2016). Interventions for female pattern hair loss. *Cochrane Database of Systematic Reviews* 2016, Issue 5. Art. No. CD007628, p. 1-2.

Cotsarelis et al. (2001). Towards a molecular understanding of hair loss and its treatment. *Trends in molecular medicine*, 7(7), 293-301.

Duverger et al. (2014). To grow or not to grow: hair morphogenesis and human genetic hair disorders. *Seminars in cell & developmental biology*. vol. 25: pp. 22-33.

Erlich et al. (2003). Nasal dorsal augmentation with silicone implants. *Facial plastic surgery*, 19(04), 325-330.

Fanous et al. (2003). Estimating implant size in chin augmentation: A simplified approach. *Canadian Journal of Plastic Surgery*, 11(3), 161-165.

Farrell et al. (2014). Effects of pore size, implantation time, and nano-surface properties on rat skin ingrowth into percutaneous porous titanium implants. *Journal of Biomedical Materials Research Part A*, 102(5), 1305-1315.

Federal Drug Administration (2016). Sec. 895.101 Prosthetic Flair Fibers. CFR Title 21, vol. 8, Chapter 1, Subchapter H, Part 895, Subpart B. Retrieved on Aug. 4, 2017 from <https://www.accessdata.fda.gov/scripts/cdrh/cfdocs/cfcfr/CFRSearch.cfm?fr=895.101>.

Fleckman et al. (2008). Models for the histologic study of the skin interface with percutaneous biomaterials. *Biomedical Materials*, 3(3), 034006: 1-24.

Fleckman et al. (2012). Cutaneous and inflammatory response to long-term percutaneous implants of spheretemplated porous/solid poly (HEMA) and silicone in mice. *Journal of Biomedical Materials Research Part A*, 100 (5), 1256-1268.

Fox et al. (2007). Traction folliculitis: an underreported entity. *Cutis*, 79(1), 26-30.

Gooding et al. (2004). The cadherin-catenin complex as a focal point of cell adhesion and signalling: new insights from three-dimensional structures. *Bioessays*, 26(5), 497-511.

Grice et al. (2011). The skin microbiome. *Nature reviews. Microbiology*, 9(4), 244-253.

Hanke et al. (1981). Hair implant complications. *JAMA*, 245(13), 1344-1345.

Hanke et al. (1981). Fiber implantation for pattern baldness. *Am Acad Dermatol* 4(3): 278-283.

Hartsock et al. (2008). Adherens and tight junctions: structure, function and connections to the actin cytoskeleton. *Biochimica et Biophysica Acta (BBA)-Biomembranes*, 1778(3), 660-669.

Hinderer, U. T. (1991). Nasal base, maxillary, and infraorbital implants—alloplastic. *Clinics in plastic surgery*, 18(1), 87-105.

Hirshburg et al. (2016). Adverse effects and safety of 5-alpha reductase inhibitors (finasteride, dutasteride): a systematic review. *The Journal of clinical and aesthetic dermatology*, 9(7), 56-62.

International Society of Hair Restoration Surgery (2003). Psychological effects of hair loss in women. Retrieved on Aug. 4, 2017 from <http://www.ishrs.org/articles/hair-loss-effects.htm>.

Jasterzbski et al. (2015). Pseudofolliculitis cutis: a vexing disorder of hair growth. *British Journal of Dermatology*, 172(4), 878-884.

Jones et al. (2013). Characterization of X-linked hypohidrotic ectodermal dysplasia (XL-HED) hair and sweat gland phenotypes using phototrichogram analysis and live confocal imaging. *American Journal of Medical Genetics Part A*, 161(7), 1585-1593.

Kaplan et al. (2012). A 5-year retrospective analysis of 5 α -reductase inhibitors in men with benign prostatic hyperplasia: finasteride has comparable urinary symptom efficacy and prostate volume reduction, but less sexual side effects and breast complications than dutasteride. *International journal of clinical practice*, 66(11), 1052-1055.

Karaçal et al. (2012). Necrosis of the donor site after hair restoration with follicular unit extraction (FUE): a case report. *Journal of Plastic, Reconstructive & Aesthetic Surgery*, 65(4), e87-e89.

Karaman et al. (2006). Androgenetic alopecia: Does its presence change our perceptions?. *International journal of dermatology*, 45(5), 565-568.

Khanna et al. (2011). Pilonidal disease. *Clinics in colon and rectal surgery*, 24(01), 046-053.

Kong et al. (2012). Skin microbiome: looking back to move forward. *Journal of Investigative Dermatology*, 132(3), 933-939.

Konishi et al. (2012). Reshaping the eyebrow by follicular unit transplantation from excised eyebrow in extended infrabrow excision blepharoplasty. *Clinical ophthalmology (Auckland, NZ)*, 6, 247-252.

Lei et al. (2016). Biofunctionalization of silicone rubber with microgroove-patterned surface and carbon-ion implantation to enhance

(56)

References Cited

OTHER PUBLICATIONS

- biocompatibility and reduce capsule formation. *International journal of nanomedicine*, 11, 5563-5572.
- Lepaw, M. I. (1979). Complications of implantation of synthetic fibers into scalps for "hair" replacement: experience with fourteen cases. *The Journal of dermatologic surgery and oncology*, 5(3), 201-204.
- Lepaw, M. I. (1980). Therapy and histopathology of complications from synthetic fiber implants for hair replacement: A presentation of one hundred cases. *Journal of the American Academy of Dermatology*, 3(2), 195-204.
- Mapes, D. (2008). The fallout of hair loss: Suffering in silence. *Skin and beauty*. NBC News. Retrieved on Aug. 4, 2017 from http://www.nbcnews.com/id/26895411/ns/health-skin_and_beauty/t/fallout-hair-loss-suffering-silence/#.WaWCdMmYbF5.
- MedlinePlus (2017). Hair loss. Health Topics. MedlinePlus. Retrieved on Aug. 4, 2017 from <https://medlineplus.gov/hairloss.html>.
- MedlinePlus (2017). Hair loss. Medical Encyclopedia. MedlinePlus. Retrieved on Aug. 4, 2017 from <https://medlineplus.gov/ency/article/003246.htm>.
- MedlinePlus (2017). Pilonidal sinus disease. Medical Encyclopedia. MedlinePlus. Retrieved on Aug. 4, 2017 from <https://medlineplus.gov/ency/article/003253.htm>.
- Mirmirani et al. (2014). Traction Alopecia. *Dermatologic clinics*, 32(2), 153-161.
- Moore et al. (2015). Molecular characterization of macrophage-biomaterial. *Adv Exp Med Biol*. 865: 109-122.
- Motofei et al. (2017). Safety Profile of Finasteride: Distribution of Adverse Effect According to Structural and Informational Dichotomies of the Mind/Brain. *Clinical Drug Investigation*, 37(6), 511-517.
- Murphy et al. (2010). The effect of mean pore size on cell attachment, proliferation and migration in collagen-glycosaminoglycan scaffolds for bone tissue engineering. *Biomaterials*, 31(3), 461-466.
- Mysore, V. (2010). Controversy: Synthetic hairs and their role in hair restoration?. *International journal of trichology*, 2(1), 42-44.
- Nayyer et al. (2016). A biodesigned nanocomposite biomaterial for auricular cartilage reconstruction. *Advanced healthcare materials*, 5(10), 1203-1212.
- Nido LTD (2006). What's new. Retrieved on Aug. 4, 2017 from http://www.nidohq.co.jp/nido_english/what/what.html.
- Niechajev, I. (2012). Facial reconstruction using porous high-density polyethylene (medpor): long-term results. *Aesthetic plastic surgery*, 36(4), 917-927.
- Oh et al. (2016). A guide to studying human hair follicle cycling in vivo. *Journal of Investigative Dermatology*, 136(1), 34-44.
- Otberg et al. (2004). Variations of hair follicle size and distribution in different body sites. *Journal of Investigative Dermatology*, 122(1), 14-19.
- Pae et al. (1975). Design and evaluation of a percutaneous transthoracic cannula. *Transactions—American Society for Artificial Internal Organs*, 22, 135-148.
- Palmieri et al. (2000). Evaluation of polyamide synthetic hair. A long-term clinical study. *Panminerva medica*, 42(1), 49-53.
- Patel et al. (2016). Solid implants in facial plastic surgery: potential complications and how to prevent them. *Facial Plastic Surgery*, 32(05), 520-531.
- Peluso et al. (1992). Cutaneous complications of artificial hair implantation: a pathological study. *Dermatology*, 184(2), 129-132.
- Perry et al. (2002). Defining pseudofolliculitis barbae in 2001: a review of the literature and current trends. *Journal of the American Academy of Dermatology*, 46(2), S113-S119.
- Poswal et al. (2011). When FUE goes wrong!. *Indian journal of dermatology*, 56(5), 517-519.
- Raposio et al. (2015). Scalp surgery: quantitative analysis of follicular unit growth. *Plastic and Reconstructive Surgery Global Open*, 3(10): 1-4.
- Rose, P. T. (2015). Hair restoration surgery: challenges and solutions. *Clinical, cosmetic and investigational dermatology*, 8, 361-370.
- Rutala et al. (2008). Guideline for disinfection and sterilization in healthcare facilities, 2008. Department of Health and Human Services. Centers for Disease Control and Prevention. pp. 1-161.
- Santiago et al. (2007). Artificial hair fiber restoration in the treatment of scalp scars. *Dermatologic surgery*, 33(1), 35-44.
- Scharschmidt et al. (2013). What lives on our skin: ecology, genomics and therapeutic opportunities of the skin microbiome. *Drug Discovery Today: Disease Mechanisms*, 10(3), e83-e89.
- Schneeberger et al. (2004). The tight junction: a multifunctional complex. *American Journal of Physiology—Cell Physiology*, 286(6), C1213-C1228.
- Sengul et al. (2009). Axillary pilonidal sinus: A case report. *North American journal of medical sciences*, 1(6), 316-318.
- Serdev et al. (2015). Polyamide hair implant (biofibre®): evaluation of efficacy and safety in a group of 133 patients. *Journal of Biological Regulators & Homeostatic Agents*, 29(1), 107-113.
- Shao et al. (2014). Follicular unit transplantation for the treatment of secondary cicatricial alopecia. *Plastic Surgery*, 22(4), 249-253.
- Shiell et al. (1990). Problems associated with synthetic fibre implants for hair replacement ("NIDO" process). *The Medical journal of Australia*, 152(10), 560.
- Sinclair et al. (2015). Androgenetic alopecia: new insights into the pathogenesis and mechanism of hair loss. *F1000Research*, 4(F1000 Faculty Rev): 585: 1-9.
- Sluysmans et al. (2017). The role of apical cell-cell junctions and associated cytoskeleton in mechanotransduction. *Biology of the Cell* (109): 139-161.
- Tang, V. W. (2006). Proteomic and bioinformatic analysis of epithelial tight junction reveals an unexpected cluster of synaptic molecules. *Biology direct*, 1(1), 37: 1-30.
- Tchernev et al. (2016). Biofibre hair implant: what is new, what is true?. *Journal of biological regulators and homeostatic agents*, 30(2 Suppl 2), 49-56.
- Figure 1 of Teumer et al. (May 2005). Follicular cell implantation: an emerging cell therapy for hair loss. In *Seminars in Plastic Surgery* (vol. 19, No. 02, pp. 193-200).
- Thiedke, C. C. (2003). Alopecia in women. *American family physician*, 67(5), 1007-1014.
- Toyoshima et al. (2012). Fully functional hair follicle regeneration through the rearrangement of stem cells and their niches. *Nature communications*, 3, 784: 1-12.
- Uebel, C. O. (2005). The punctiform technique in hair transplantation. *Seminars in Plastic Surgery*, vol. 19, No. 02, pp. 109-127.
- Underwood et al. (2011). Quantifying the effect of pore size and surface treatment on epidermal incorporation into percutaneously implanted sphere-templated porous biomaterials in mice. *Journal of Biomedical Materials Research Part A*, 98(4), 499-508.
- Unknown. (2017). Image of hair root. *Trends in Molecular Medicine*. Retrieved on Aug. 24, 2017 from <http://www.cell.com/cms/attachment/553998/3951952/gr1.jpg>.
- Unknown. (2015). Image of Hair transplant surgery scars in donor area with follicular unit extraction technique. Retrieved on Aug. 25, 2017 from http://ae154z115g.previewdomain.jp/wp-content/uploads/2015/11/003_BK2.jpg.
- Unknown. (2013). Image of Galea aponeurotica seen through scalp incision. Retrieved on Aug. 24, 2017 from <http://www.the-dermatologist.com/sites/default/files/issues/Screen%20Shot%202013-08-20%20at%209.00.40%20AM.png>.
- Unknown (2015). Galea aponeurotica diagram. Retrieved on Aug. 25, 2017 from <http://www.learnneurosurgery.com/uploads/1/6/6/8/16689668/1813531.jpg?702>.
- Unknown (2015). Galea aponeurotica diagram with head in view. Retrieved on Aug. 24, 2017 from http://www.ouism.com/hairloss_files/image001.jpg.
- Vanhoestenbergh et al. (2013). Corrosion of silicon integrated circuits and lifetime predictions in implantable electronic devices. *Journal of neural engineering*, 10(3), 031002: 1-13.
- Wai, S. (2014). What is hair implant?. *Skin health: the creation of beauty is art*. Retrieved on Aug. 24, 2017 from <http://skinhealthsubang.blogspot.com/2014/08/what-is-hair-implant.html>.
- Abstract of Wan et al. (2017). Solvent Bonding for Fabrication of PMMA and COP Microfluidic Devices. *JoVE (Journal of Visualized Experiments)*, (119), e55175-e55175.

(56)

References Cited

OTHER PUBLICATIONS

Wikipedia (2017). Injection molding of liquid silicone rubber. Wikipedia, the free encyclopedia. Retrieved on Aug. 24, 2017 from https://en.wikipedia.org/w/index.php?title=Injection_molding_of_liquid_silicone_rubber&oldid=787919147.

Wikipedia (2017). Injection moulding. Wikipedia, the free encyclopedia. Retrieved on Aug. 7, 2017 from https://en.wikipedia.org/w/index.php?title=Injection_moulding&oldid=794136890.

Wikipedia (2017). Silicone rubber. Wikipedia, the free encyclopedia. Retrieved on Aug. 7, 2017 from https://en.wikipedia.org/w/index.php?title=Silicone_rubber&oldid=788264103.

Wilt et al. (2008). 5-alpha-reductase inhibitors for prostate cancer prevention (review). Cochrane Database of Systematic Reviews, Issue 2: 1-61.

* cited by examiner

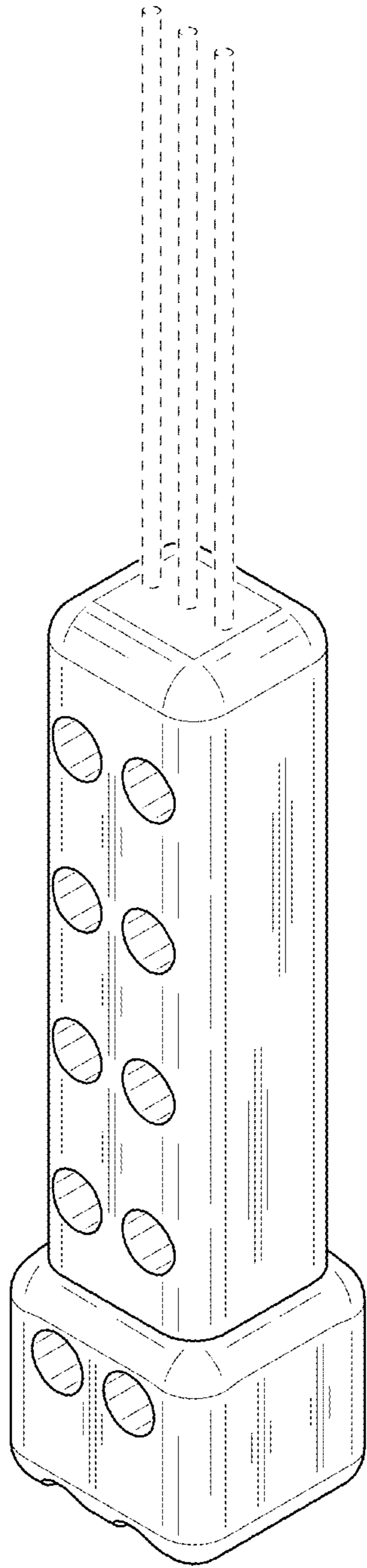

FIG. 1

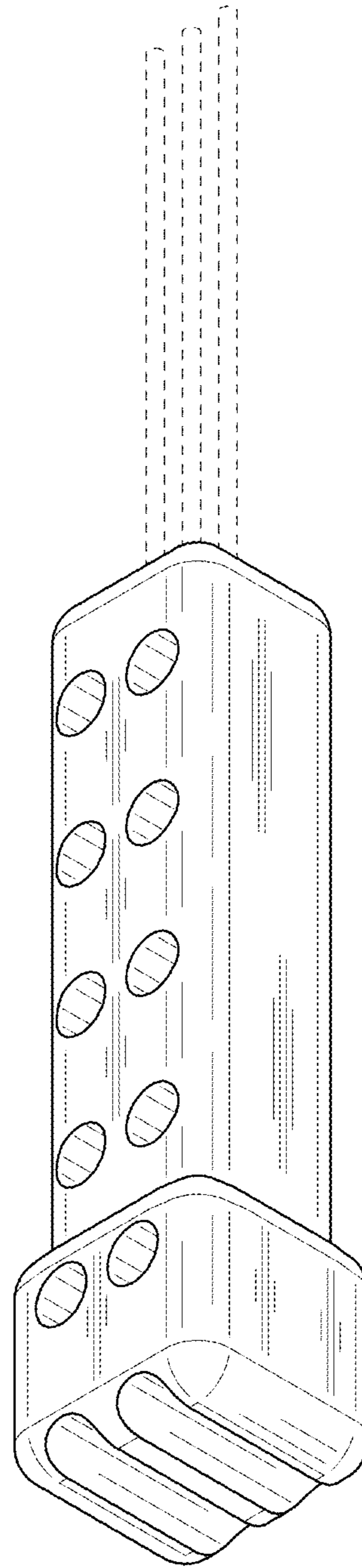

FIG. 2

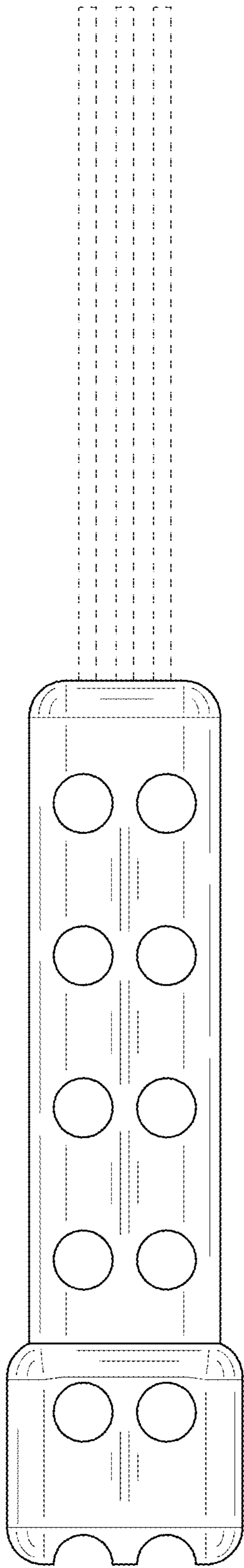

FIG. 3

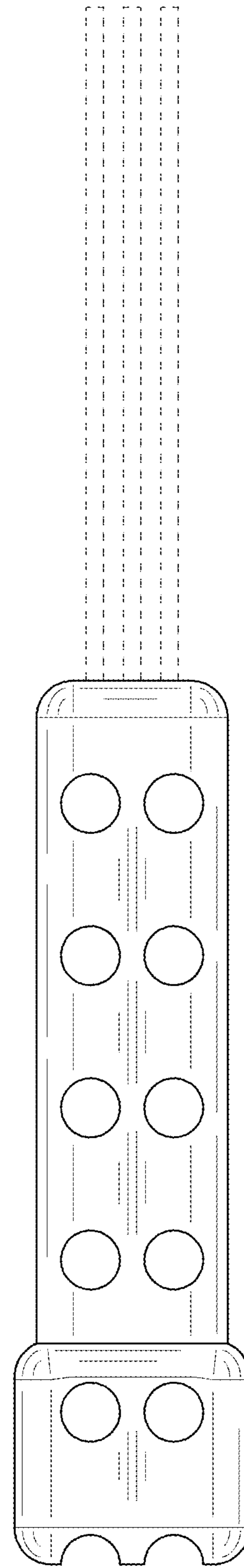

FIG. 4

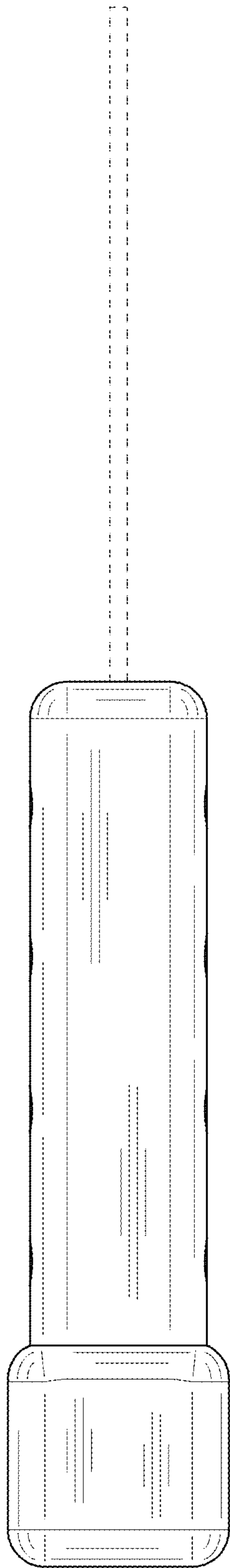

FIG. 5

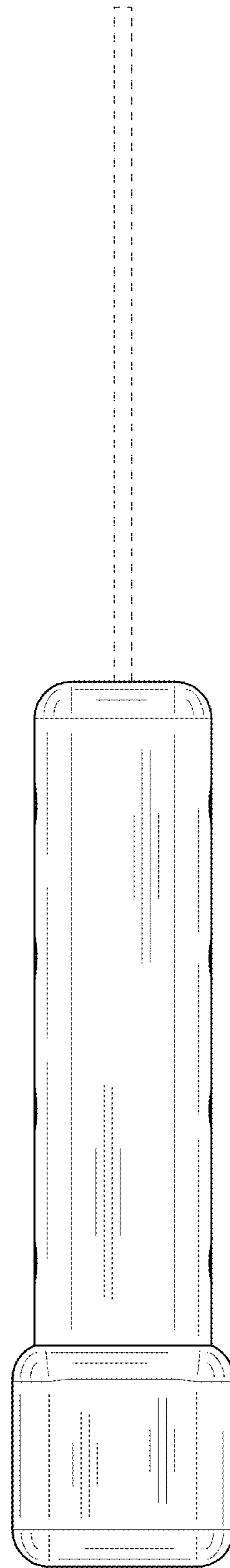

FIG. 6

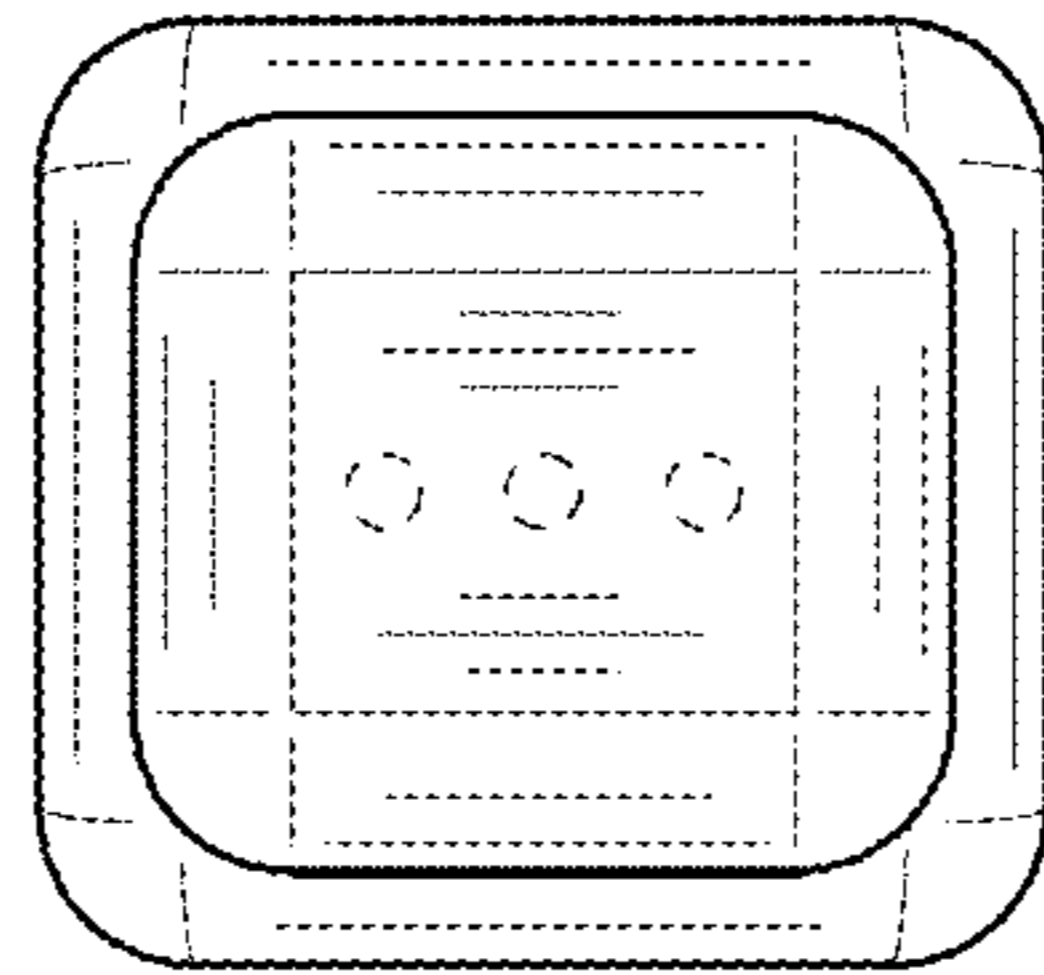

FIG. 7

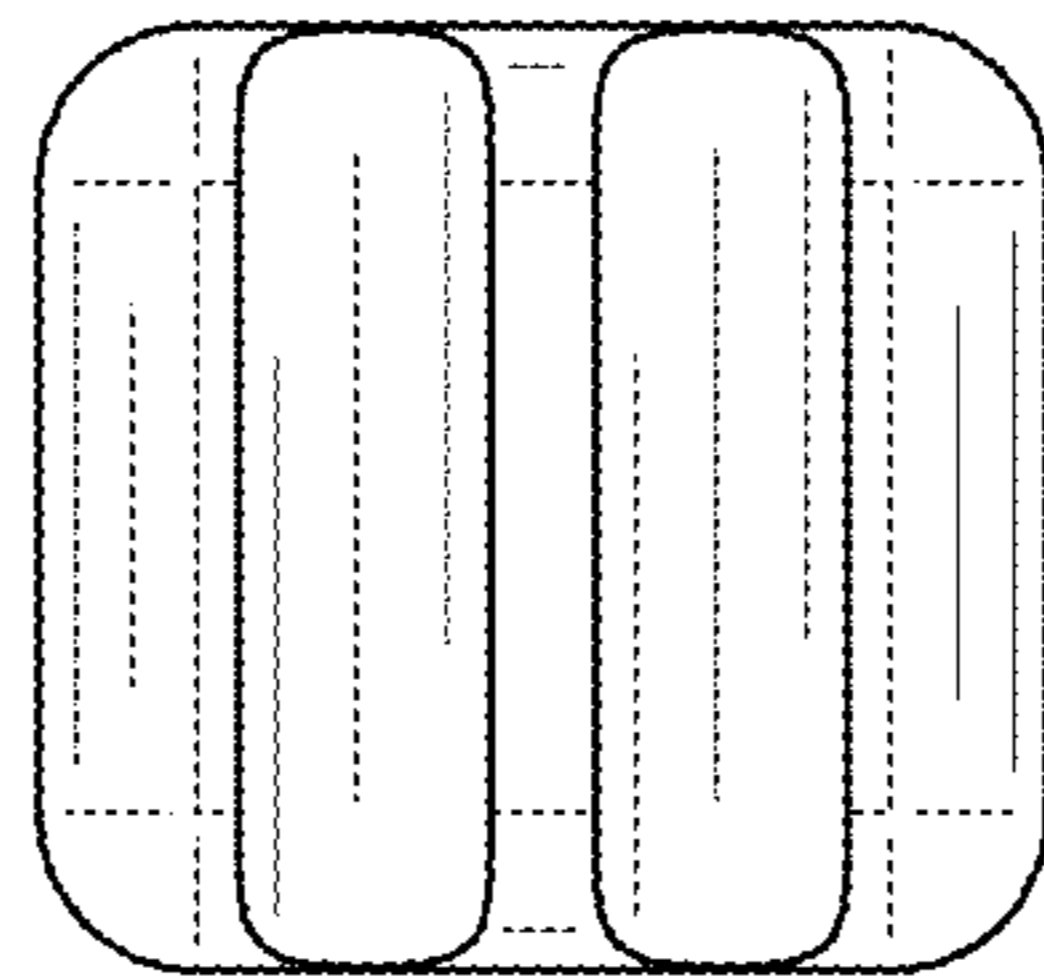

FIG. 8

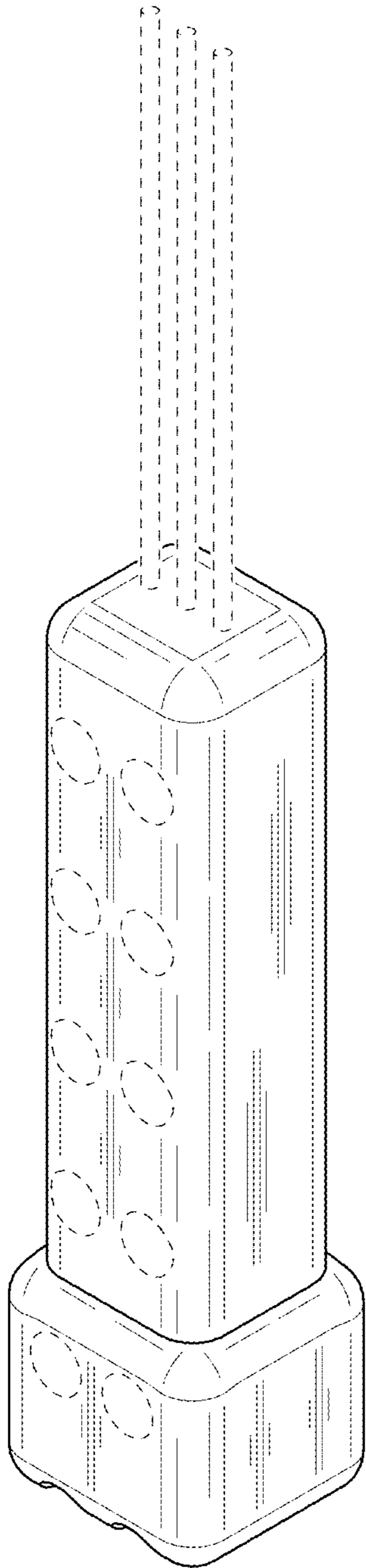

FIG. 9

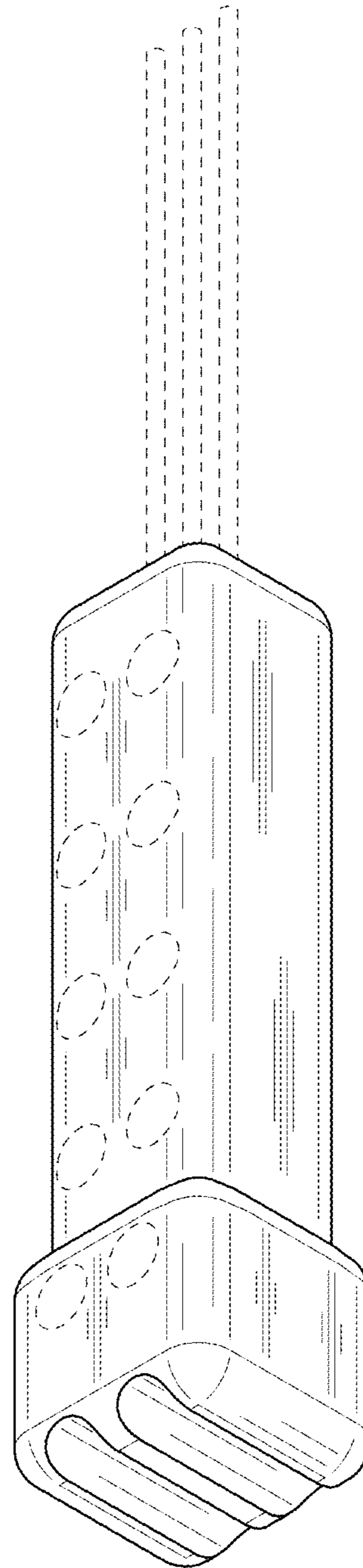

FIG. 10

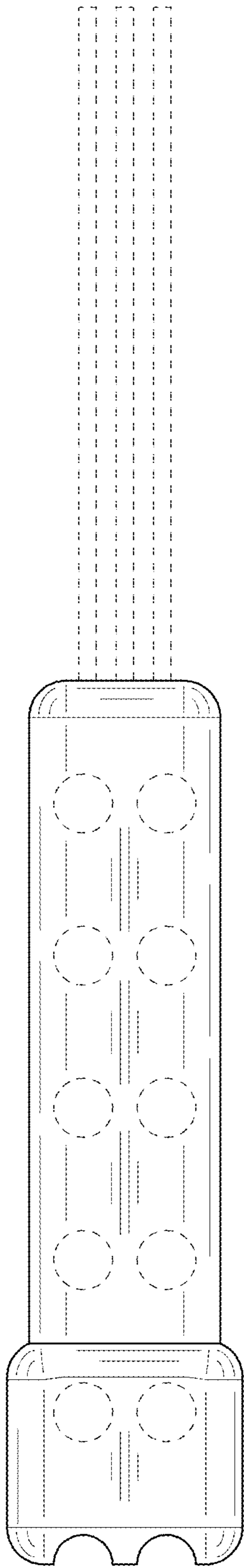

FIG. 11

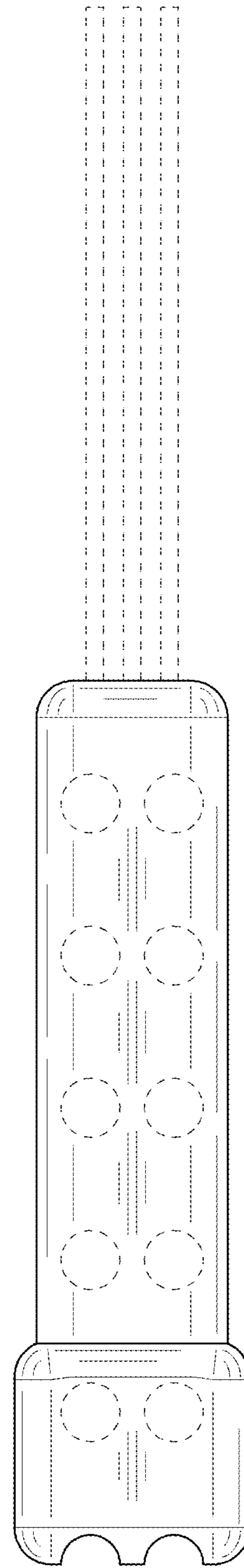

FIG. 12

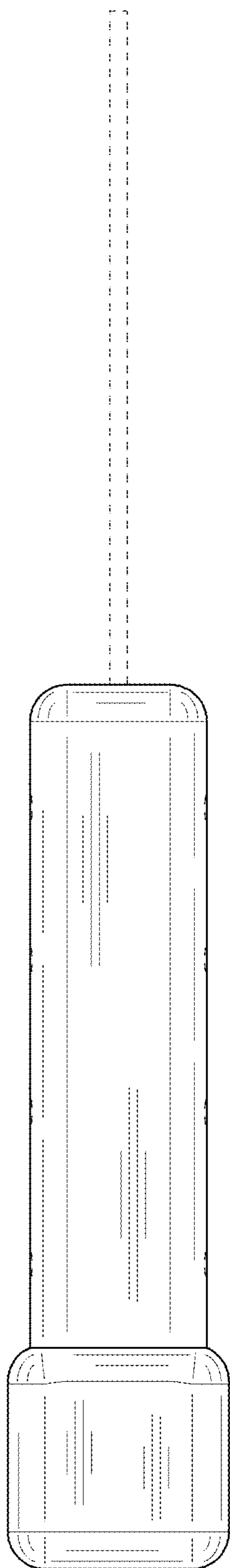

FIG. 13

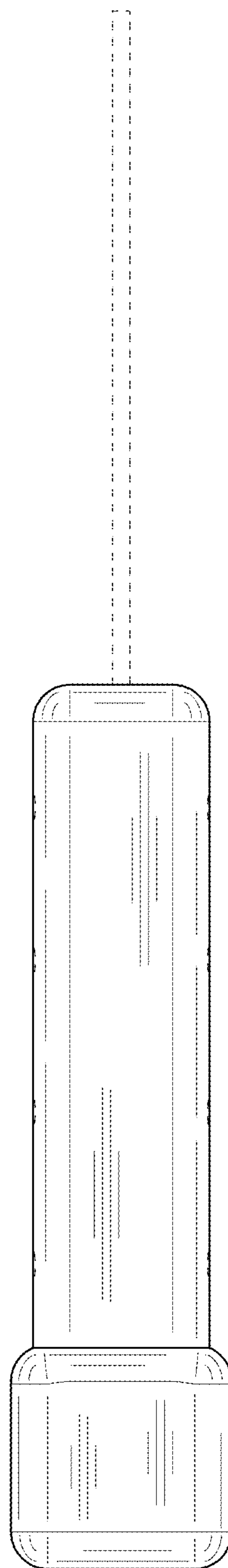

FIG. 14

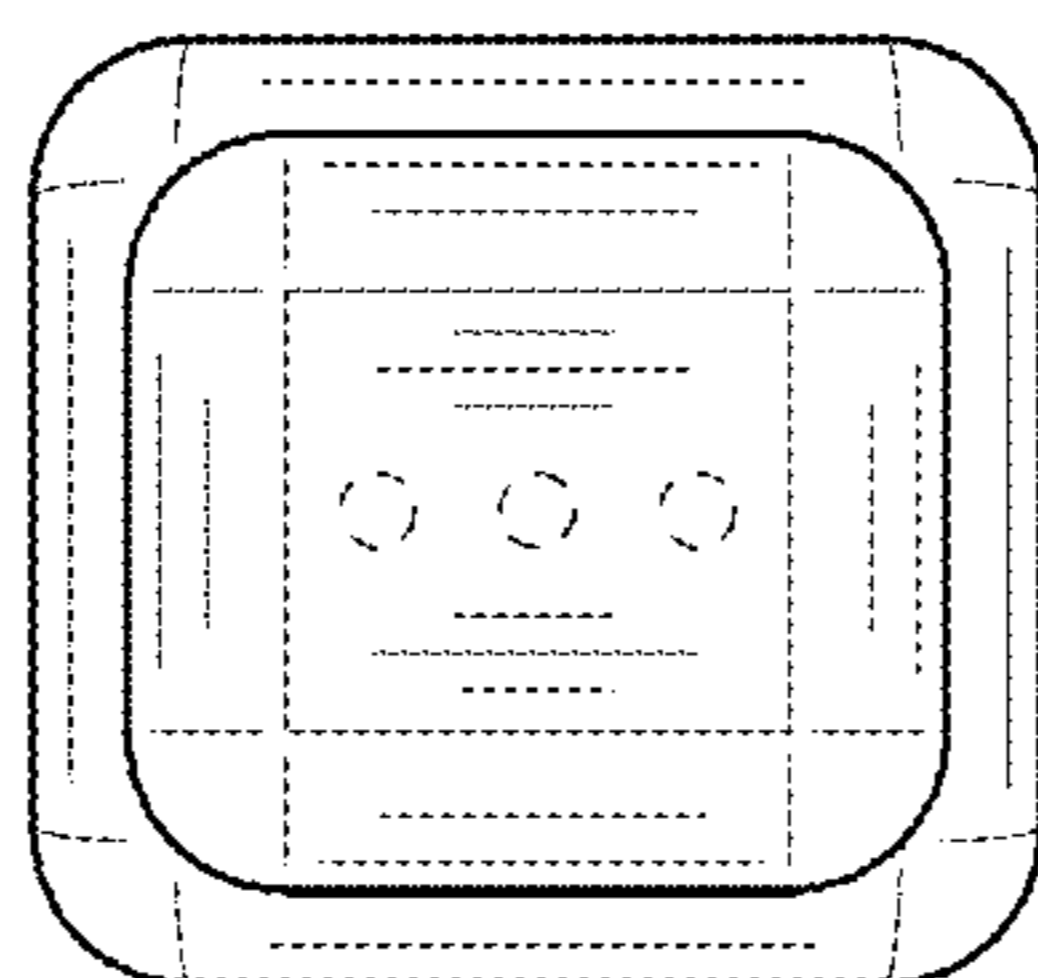

FIG. 15

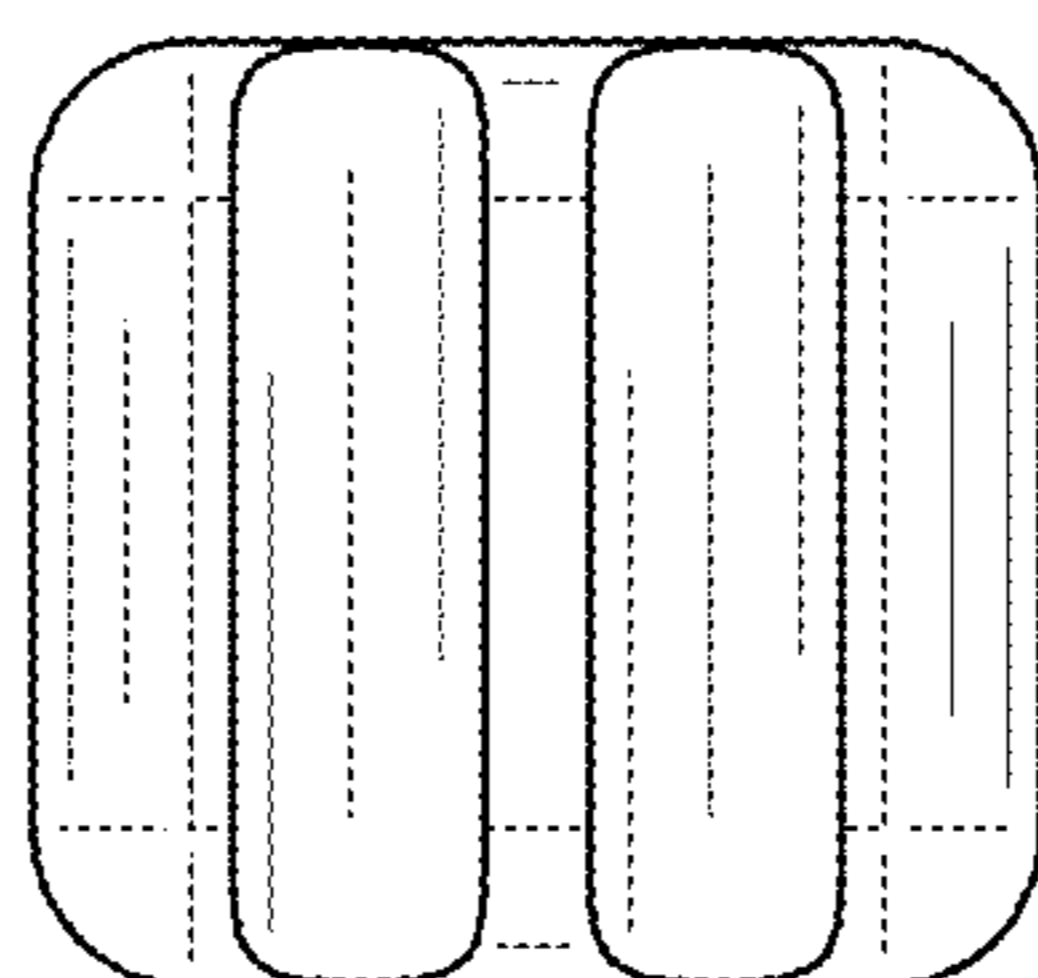

FIG. 16