



US00D916202S

(12) **United States Design Patent** (10) **Patent No.:** **US D916,202 S**
Wang et al. (45) **Date of Patent:** **** Apr. 13, 2021**

(54) **QUADRUPED ROBOT**

(71) Applicant: **HangZhou YuShu TECHNOLOGY CO., LTD.**, Zhejiang (CN)

(72) Inventors: **Xingxing Wang**, Zhejiang (CN); **Zhiyu Yang**, Zhejiang (CN)

(**) Term: **15 Years**

(21) Appl. No.: **29/718,514**

(22) Filed: **Dec. 25, 2019**

(30) **Foreign Application Priority Data**

Apr. 26, 2019 (CN) 201930197480.9

(51) **LOC (13) Cl.** **21-02**

(52) **U.S. Cl.**
USPC **D21/578**

(58) **Field of Classification Search**
USPC D21/578–583, 621–622
CPC B25J 9/0006; B25J 9/0009; B25J 9/0003;
B25J 9/00

See application file for complete search history.

(56) **References Cited**

U.S. PATENT DOCUMENTS

D445,849 S *	7/2001	Saito	D21/578
D454,378 S *	3/2002	Hornsby	D21/578
D457,203 S *	5/2002	Onishi	D21/578
D457,205 S *	5/2002	Hornsby	D21/578
D461,857 S *	8/2002	Hornsby	D21/578
D483,816 S *	12/2003	Nakase	D21/578
D484,196 S *	12/2003	Nakase	D21/578
D507,309 S *	7/2005	Nakase	D21/578
D598,964 S *	8/2009	Harano	D21/578
D783,736 S *	4/2017	Goldsmith	D21/578
D811,494 S *	2/2018	Lee	D21/654
D882,705 S *	4/2020	Lee	D21/578
D883,402 S *	5/2020	Lee	D21/578
D891,536 S *	7/2020	Fantino	D21/584
2020/0282554 A1 *	9/2020	Wang	B25J 9/126

OTHER PUBLICATIONS

“Unitree Robotics A1” Aug. 4, 2020 site visited Jan. 28, 2021: <https://web.archive.org/web/20200804170059/https://www.unitree.com/products/a1/> (Year: 2020).*

“Hyperbeast” Nov. 11, 2019, site visited Feb. 22, 2021: <https://hypebeast.com/2019/11/mit-mini-cheetah-robots-play-soccer-campus> (Year: 2019).*

“Laikago’s some new skills in 2018 , Our new robot(2019) coming soon!” Apr. 11, 2019 site visited Feb. 22, 2021 <https://youtu.be/Q4ULSaAonWs> (Year: 2019).*

* cited by examiner

Primary Examiner — Michael C Stout

Assistant Examiner — Melvin L Davis

(74) *Attorney, Agent, or Firm* — ZANIP

(57) **CLAIM**

The ornamental design for a quadruped robot, as shown and described.

DESCRIPTION

FIG. 1 is a front and top perspective view of a quadruped robot, showing our new design;

FIG. 2 is a front and bottom perspective view thereof;

FIG. 3 is a front elevational view thereof;

FIG. 4 is a rear elevational view thereof;

FIG. 5 is a left side elevational view thereof;

FIG. 6 is a right side elevational view thereof;

FIG. 7 is a top plan view thereof;

FIG. 8 is a bottom plan view thereof;

FIG. 9 is an enlarged view of a portion indicated, in FIG. 1; and,

FIG. 10 is an enlarged view of a portion indicated in FIG. 2.

The broken lines in the figures illustrate portions of the quadruped robot that form no part of the claimed design.

1 Claim, 10 Drawing Sheets

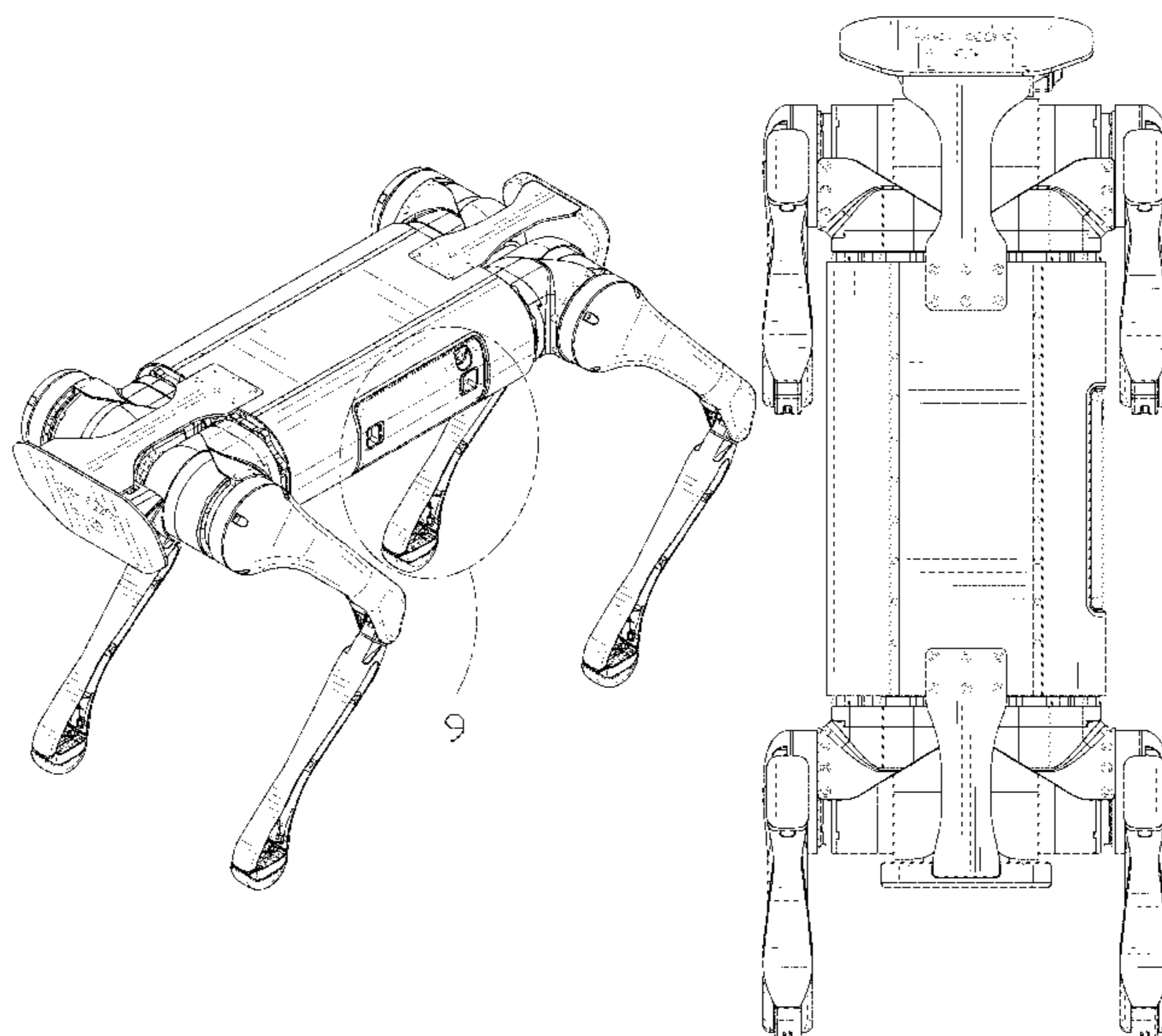

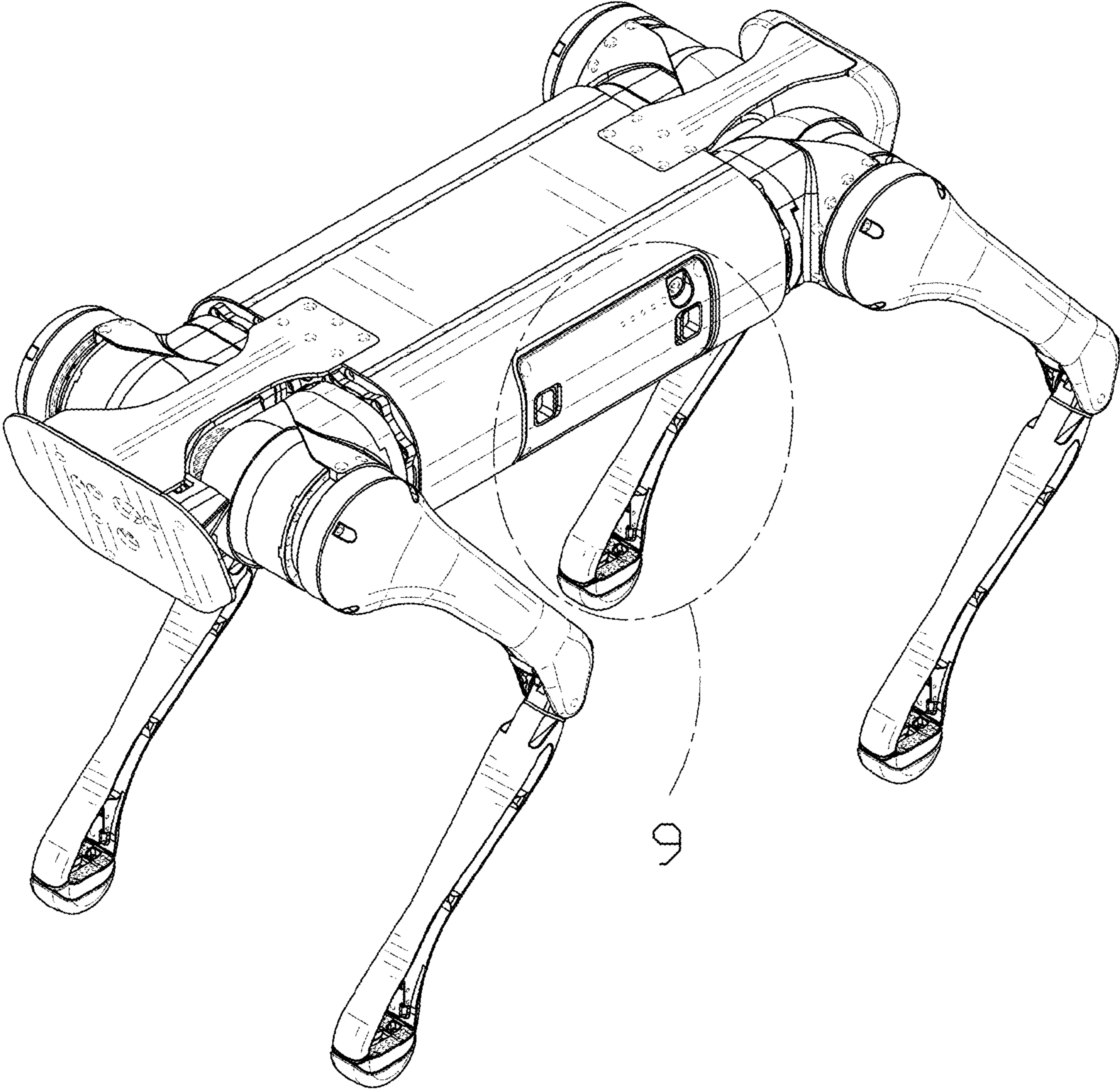

FIG. 1

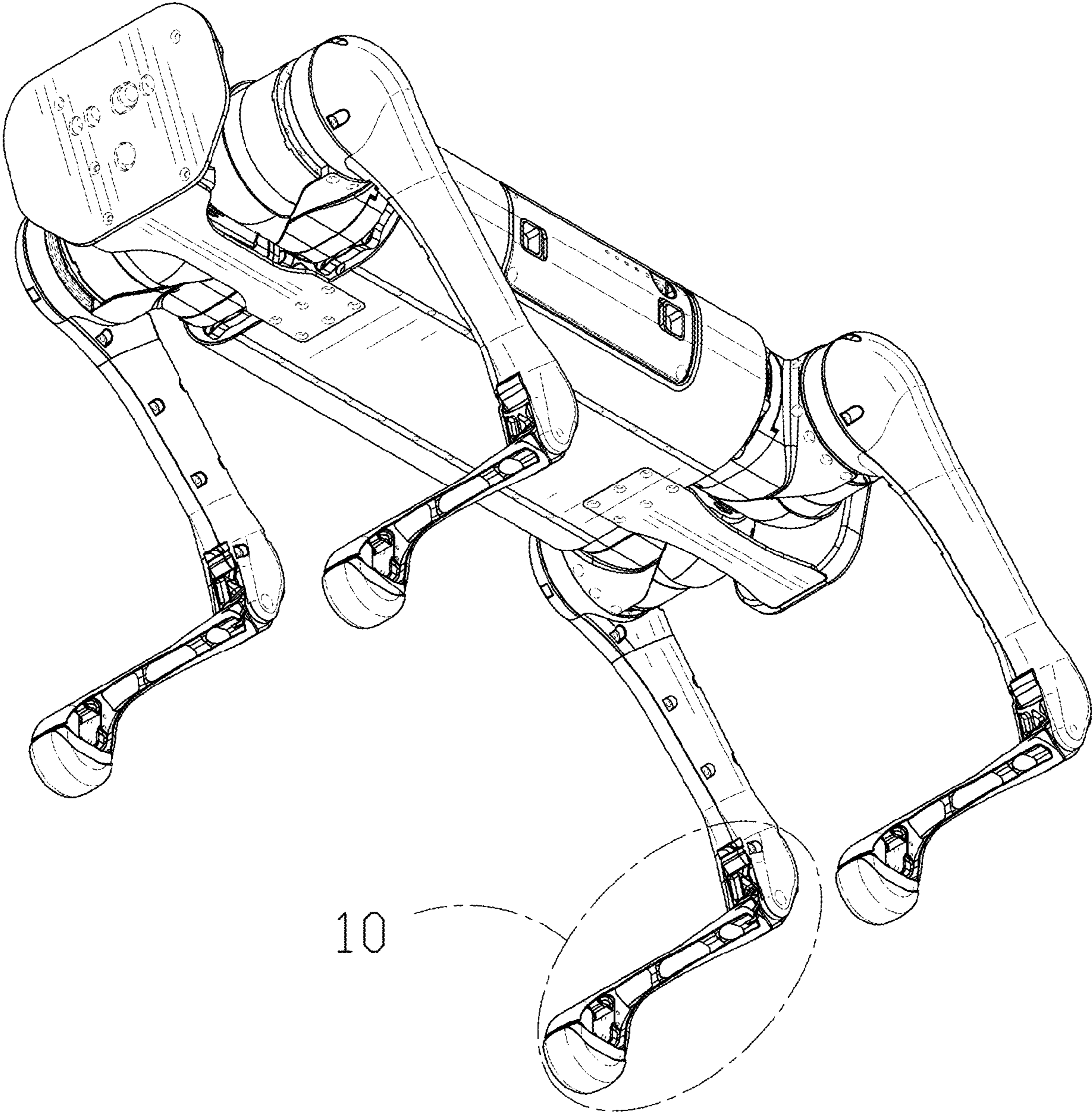

FIG. 2

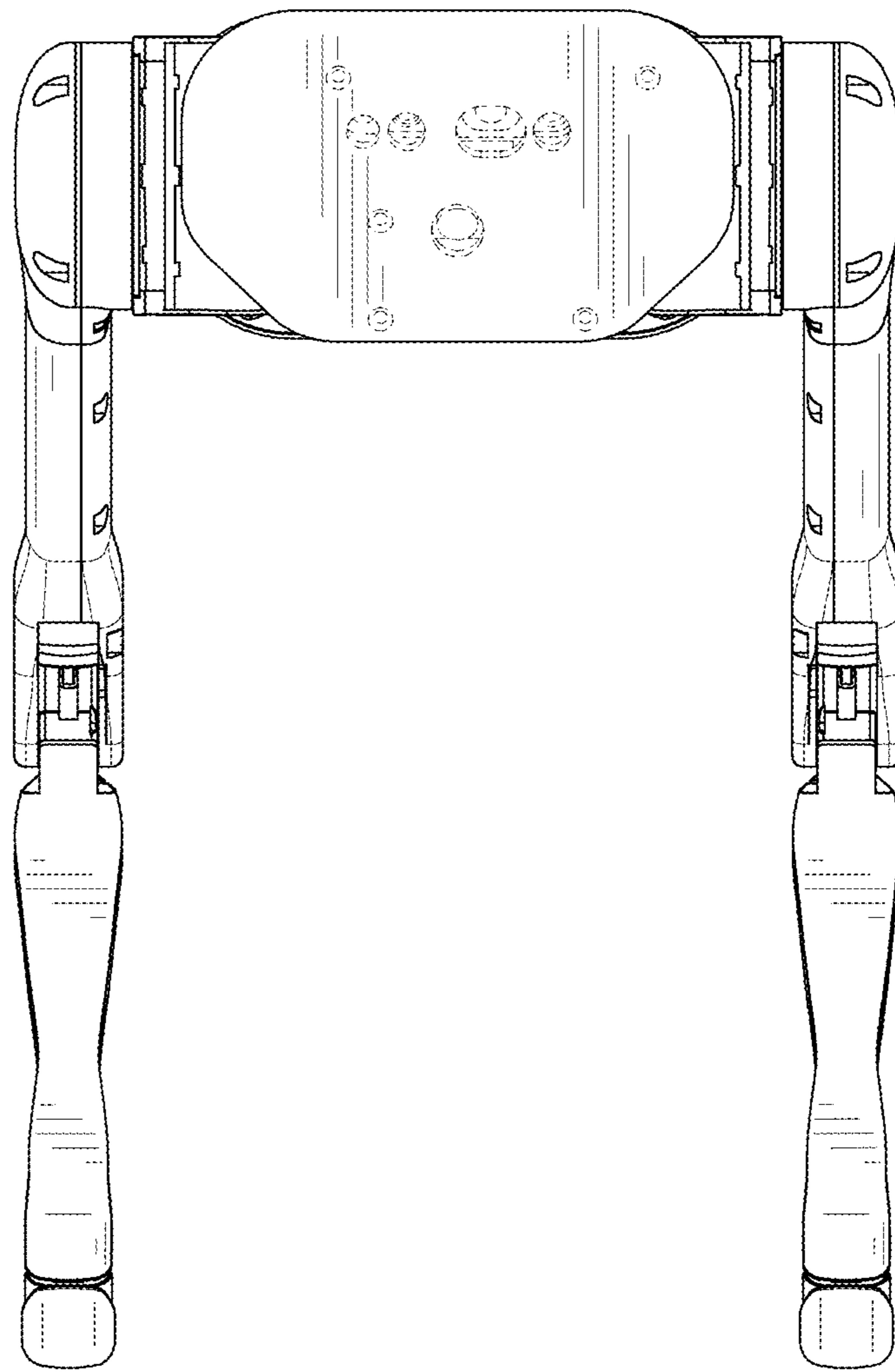

FIG. 3

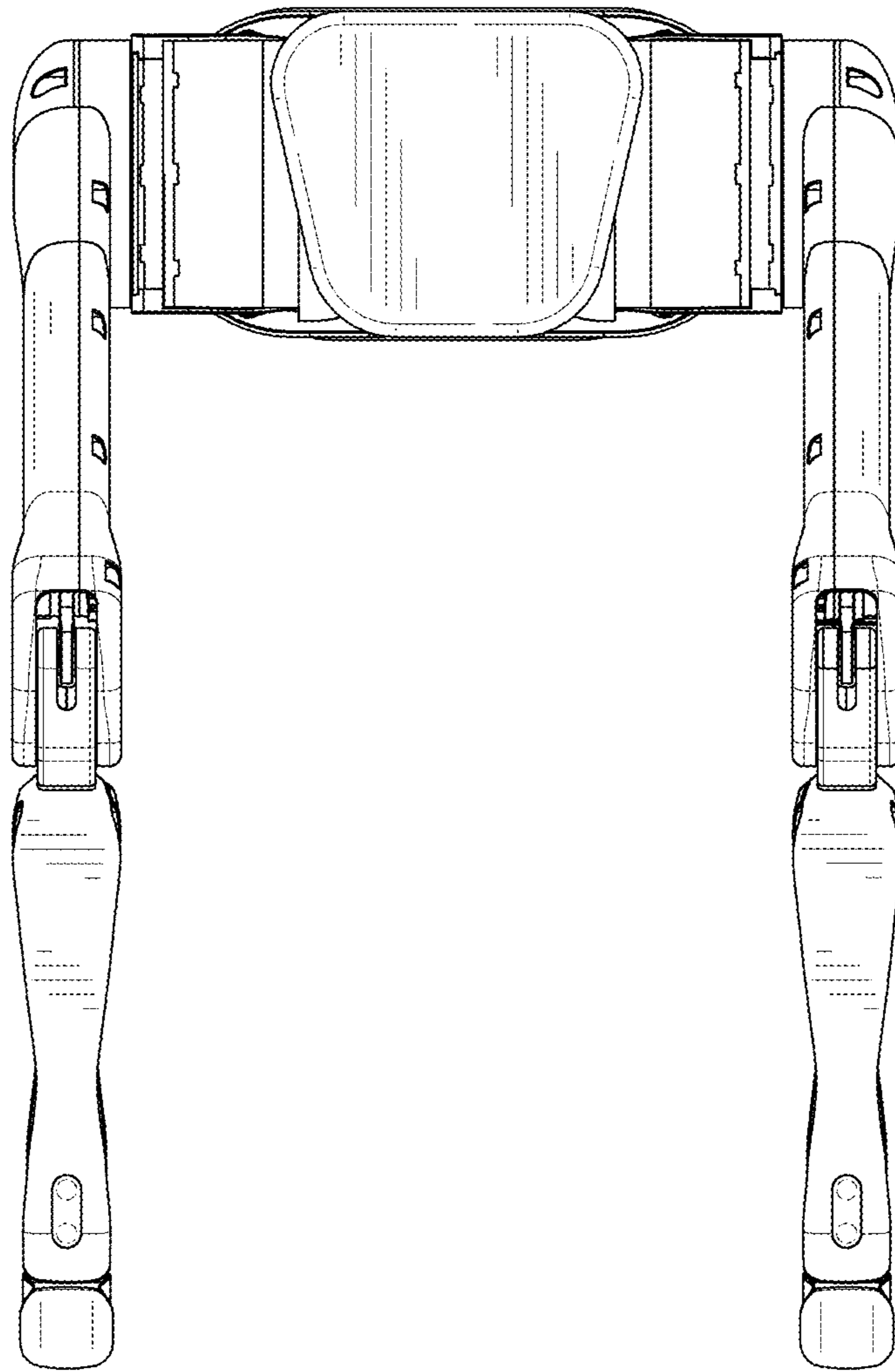

FIG. 4

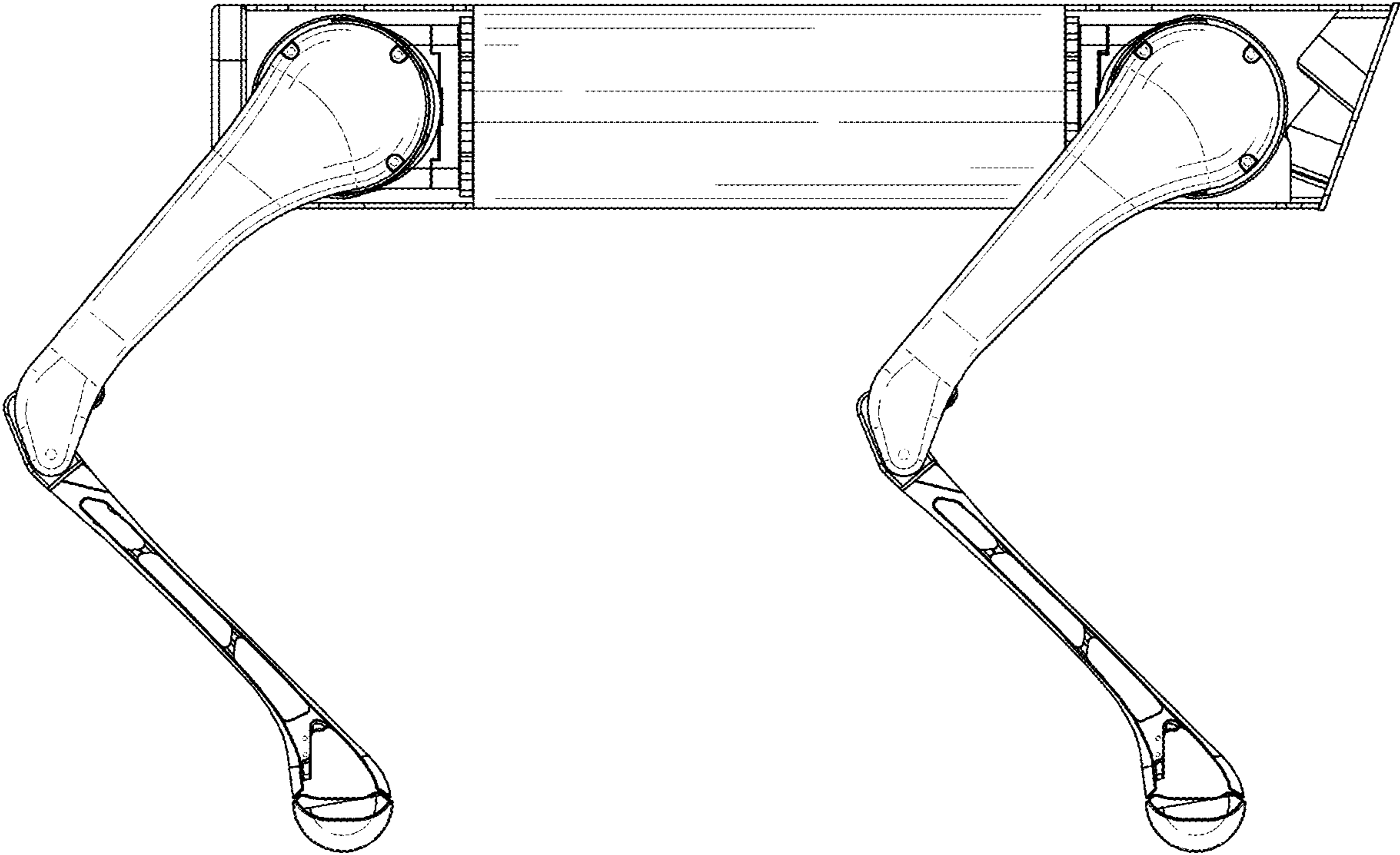

FIG. 5

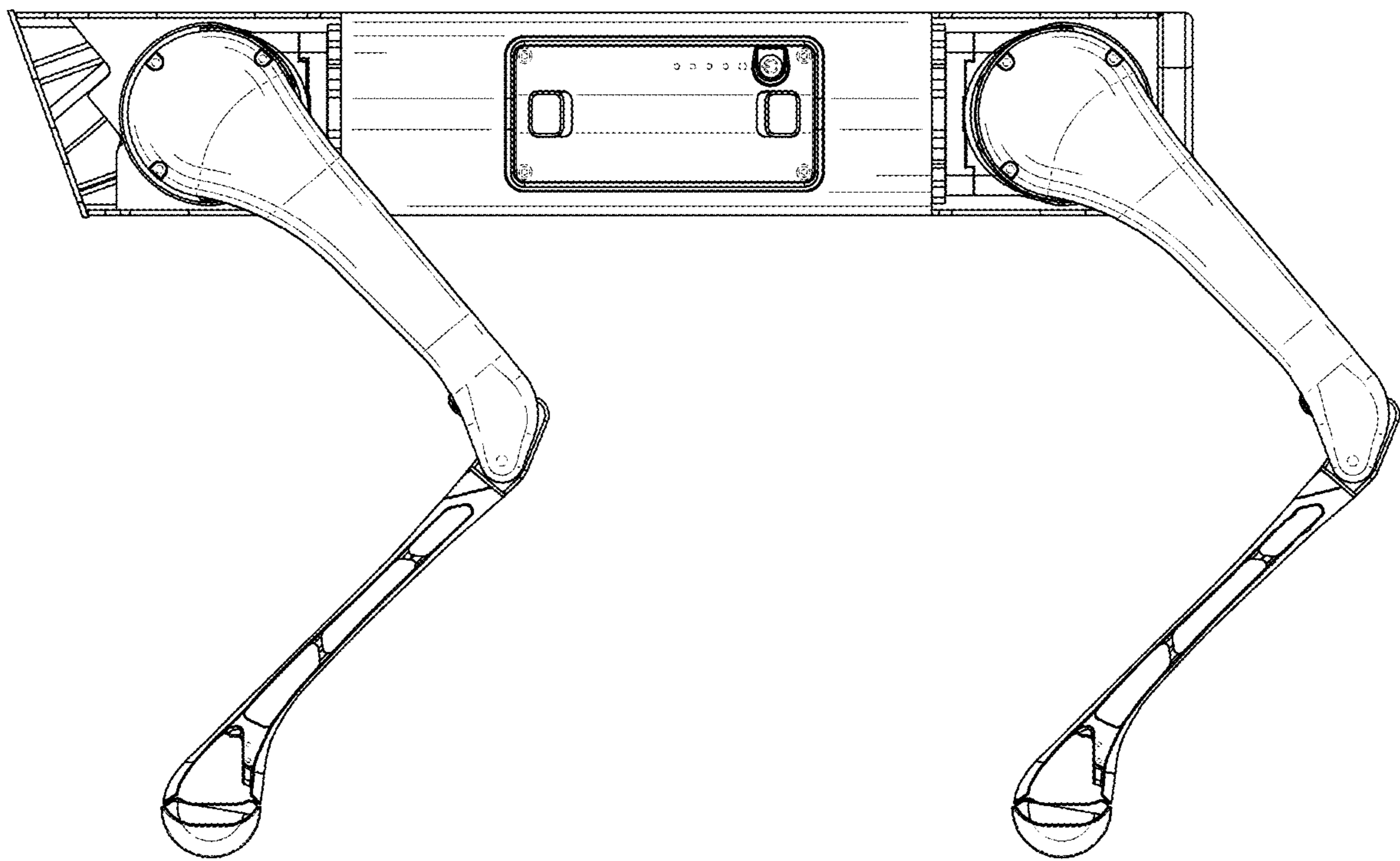

FIG. 6

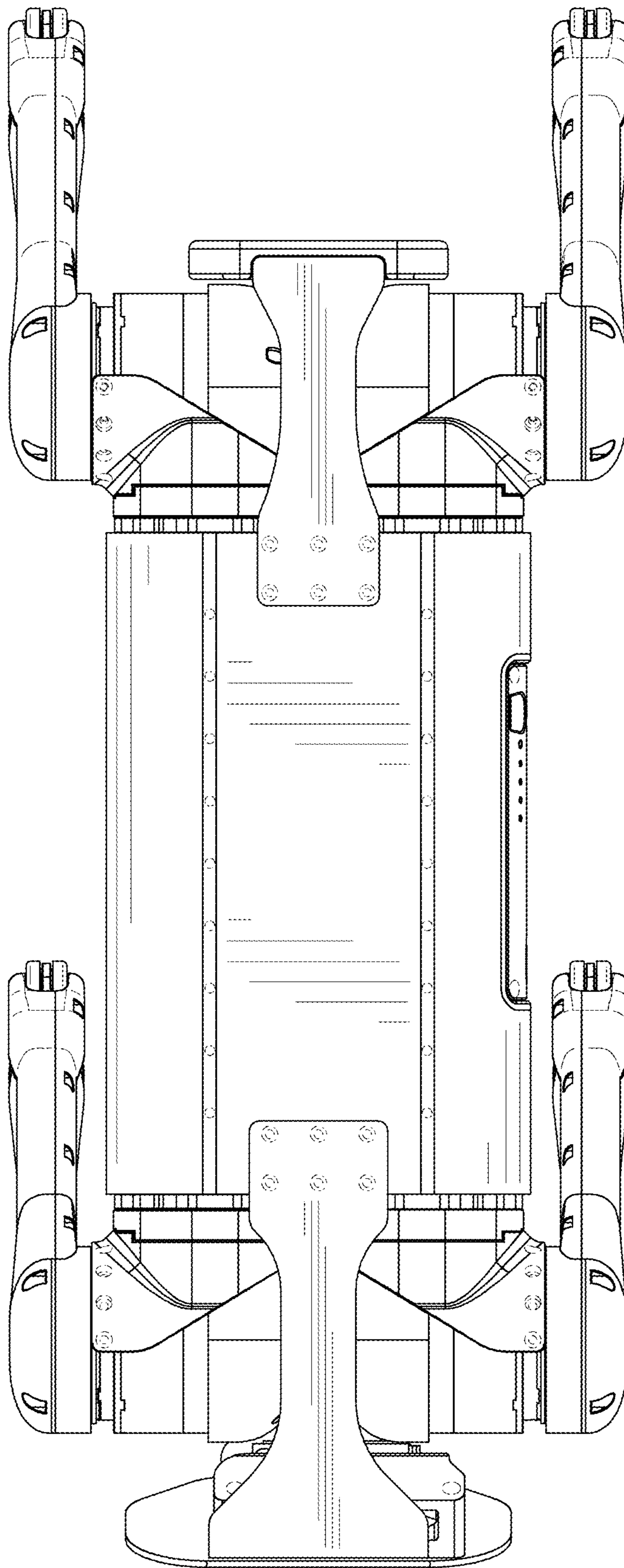

FIG. 7

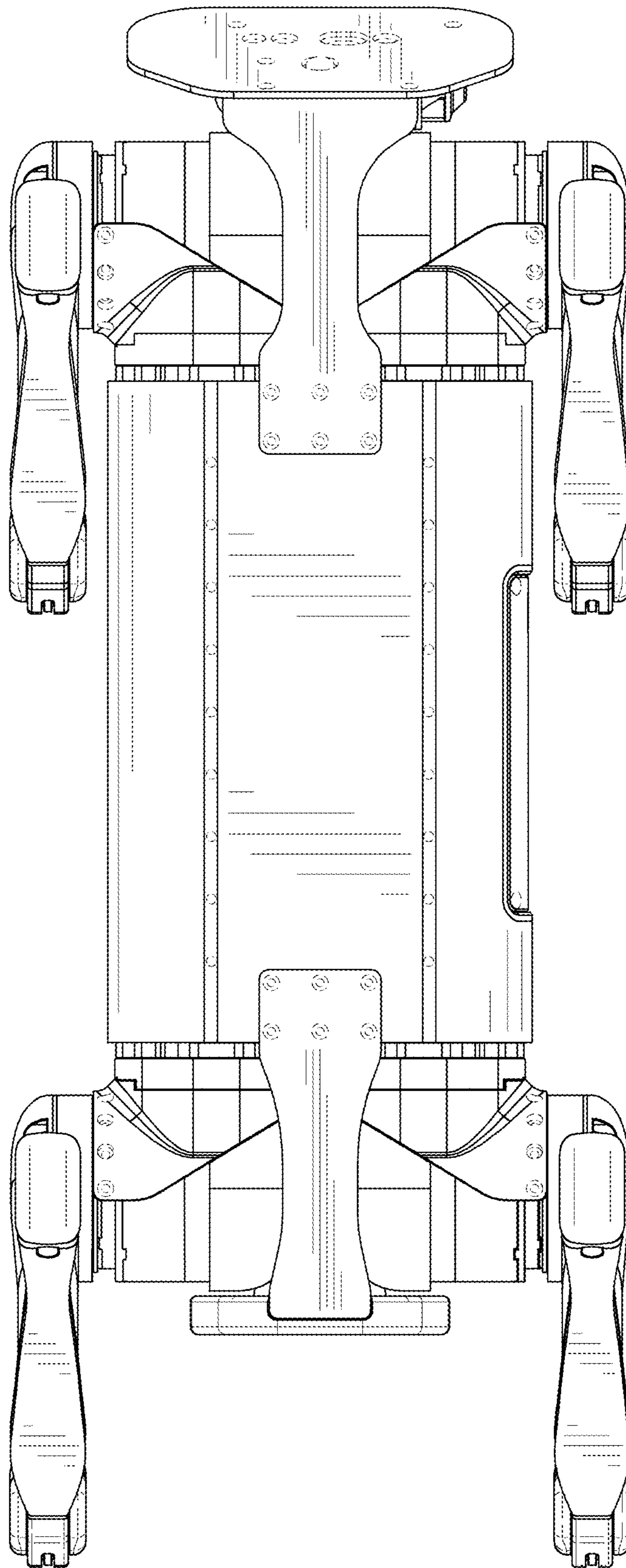

FIG. 8

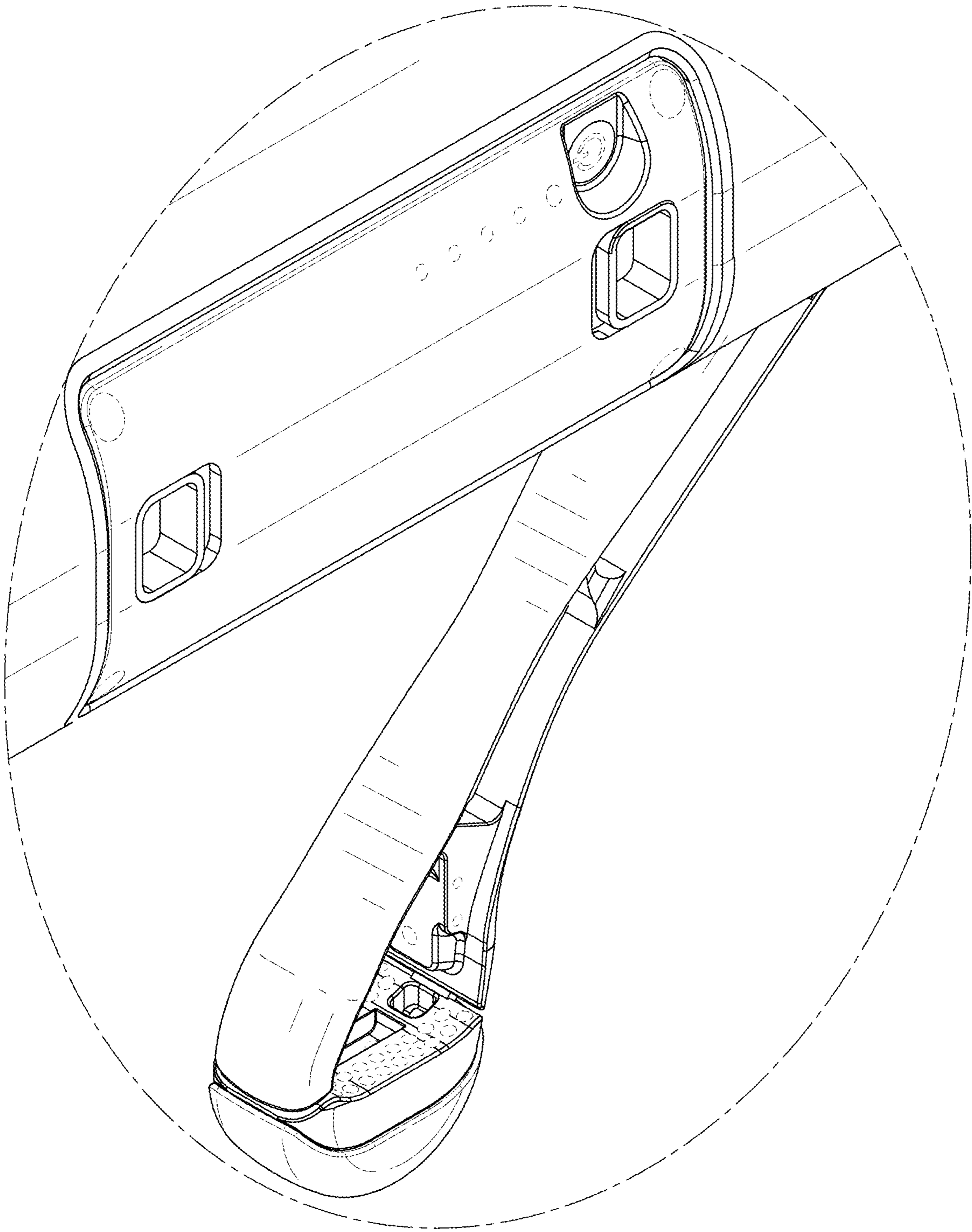

FIG. 9

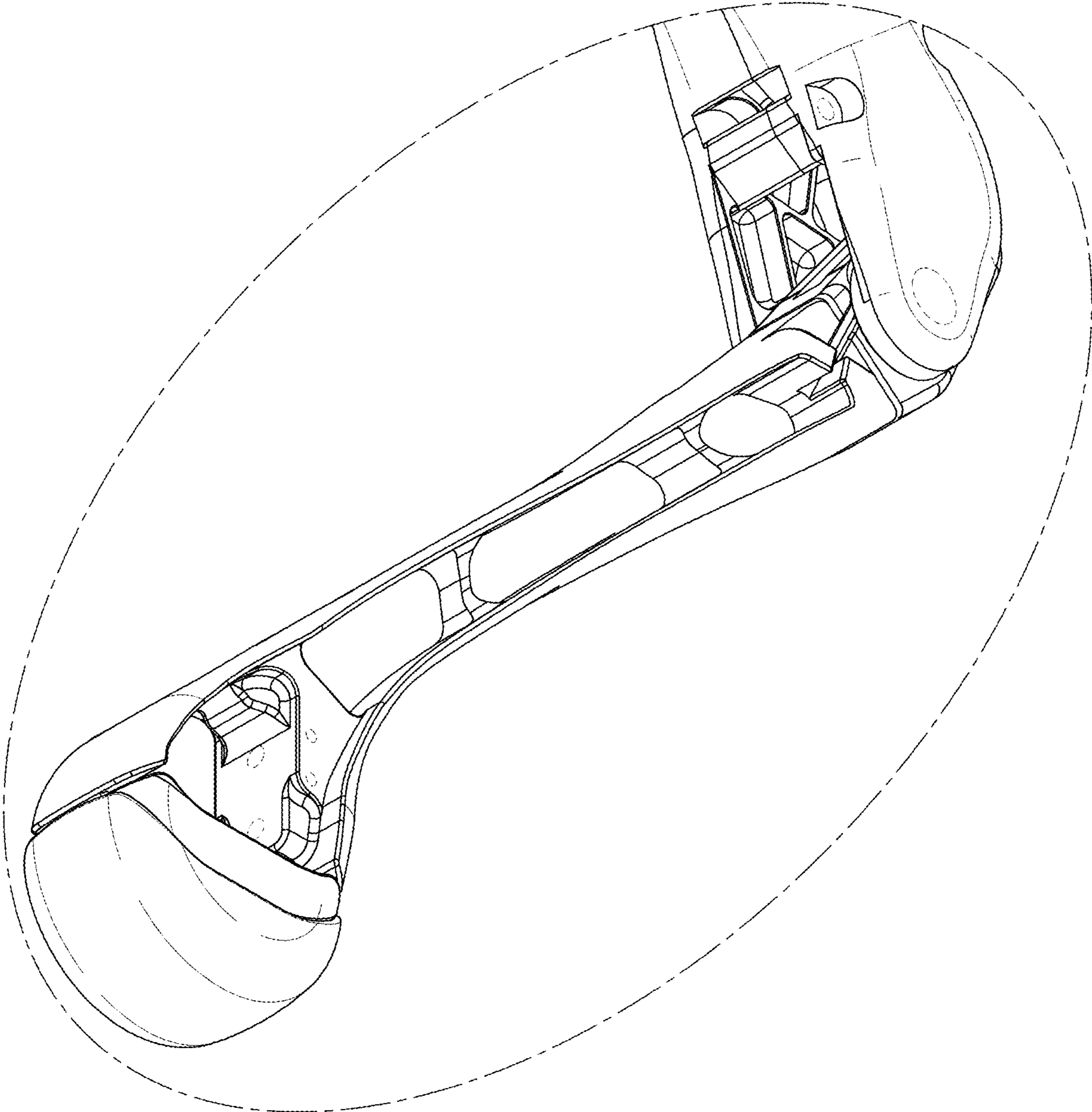

FIG. 10