



US00D916201S

(12) **United States Design Patent**
Zemskov

(10) **Patent No.:** **US D916,201 S**
(45) **Date of Patent:** **** Apr. 13, 2021**

- (54) **RIDE ON VEHICLE**
- (71) Applicant: **Radio Flyer Inc.**, Chicago, IL (US)
- (72) Inventor: **Igor Zemskov**, Chicago, IL (US)
- (73) Assignee: **Radio Flyer Inc.**, Chicago, IL (US)
- (**) Term: **15 Years**
- (21) Appl. No.: **29/708,712**
- (22) Filed: **Oct. 9, 2019**
- (51) **LOC (13) Cl.** **21-01**
- (52) **U.S. Cl.**
USPC **D21/433**
- (58) **Field of Classification Search**
USPC D21/412, 414–417, 419, 424, 426–429,
D21/433
CPC A63G 19/00; A63G 19/02; A63G 19/04;
A63G 13/00; A63G 13/10; A63G 15/00;
A63G 15/04
See application file for complete search history.

D719,618 S * 12/2014 Herlitz D21/424
D892,938 S * 8/2020 Sturgeon D21/433
2012/0211955 A1* 8/2012 Herlitz B62K 9/00
280/33.998

* cited by examiner

Primary Examiner — Cynthia M. Chin
(74) *Attorney, Agent, or Firm* — Barnes & Thornburg
LLP

(57) **CLAIM**

I claim the ornamental design for a ride on vehicle, as shown and described.

DESCRIPTION

FIG. 1 is a front top perspective view of the ride on vehicle according to the new design.
FIG. 2 is a rear bottom perspective view of the ride on vehicle shown in FIG. 1.
FIG. 3 is a front elevation view of the ride on vehicle shown in FIG. 1.
FIG. 4 is a rear elevation view of the ride on vehicle shown in FIG. 1.
FIG. 5 is a left side elevation view of the ride on vehicle shown in FIG. 1.
FIG. 6 is a right side elevation view of the ride on vehicle shown in FIG. 1.
FIG. 7 is a top view of the ride on vehicle shown in FIG. 1; and,
FIG. 8 is a bottom view of the ride on vehicle shown in FIG. 1.
The broken lines in the drawings illustrate portions of the ride on vehicle that form no part of the claimed design.

(56) **References Cited**

U.S. PATENT DOCUMENTS

- D252,653 S * 8/1979 Nakao D21/428
- D261,784 S * 11/1981 Fisher D21/424
- D264,234 S * 5/1982 Nakao D21/433
- D272,551 S * 2/1984 Nakao D21/428
- D282,184 S * 1/1986 Nakao D21/433
- D285,323 S * 8/1986 Appel D21/435
- D320,239 S * 9/1991 Kassai D21/424
- D352,741 S * 11/1994 Nakai D21/424
- D439,934 S * 4/2001 Wang D21/433
- D456,858 S * 5/2002 Huntsberger D21/433
- D533,603 S * 12/2006 Chung D21/433

1 Claim, 8 Drawing Sheets

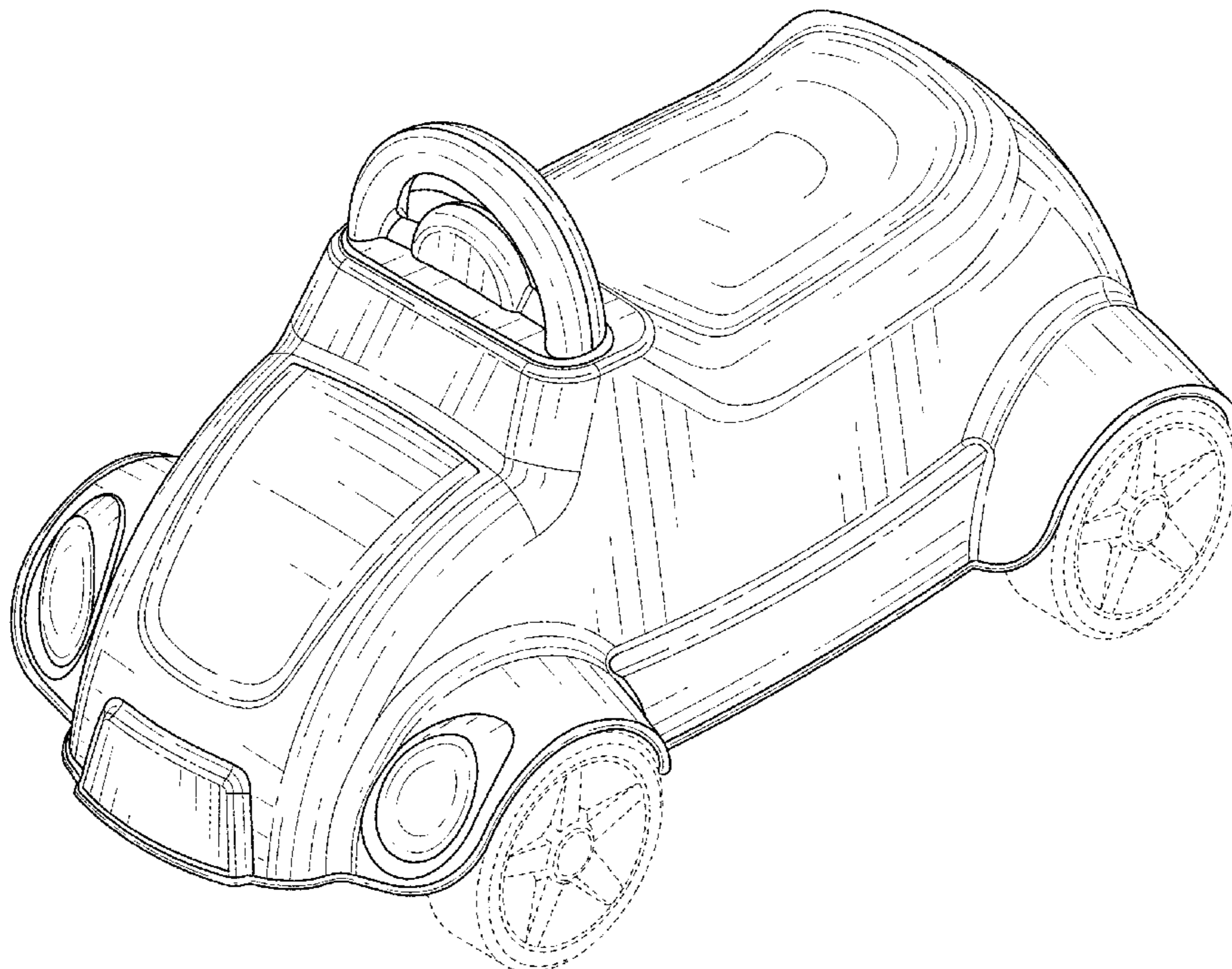

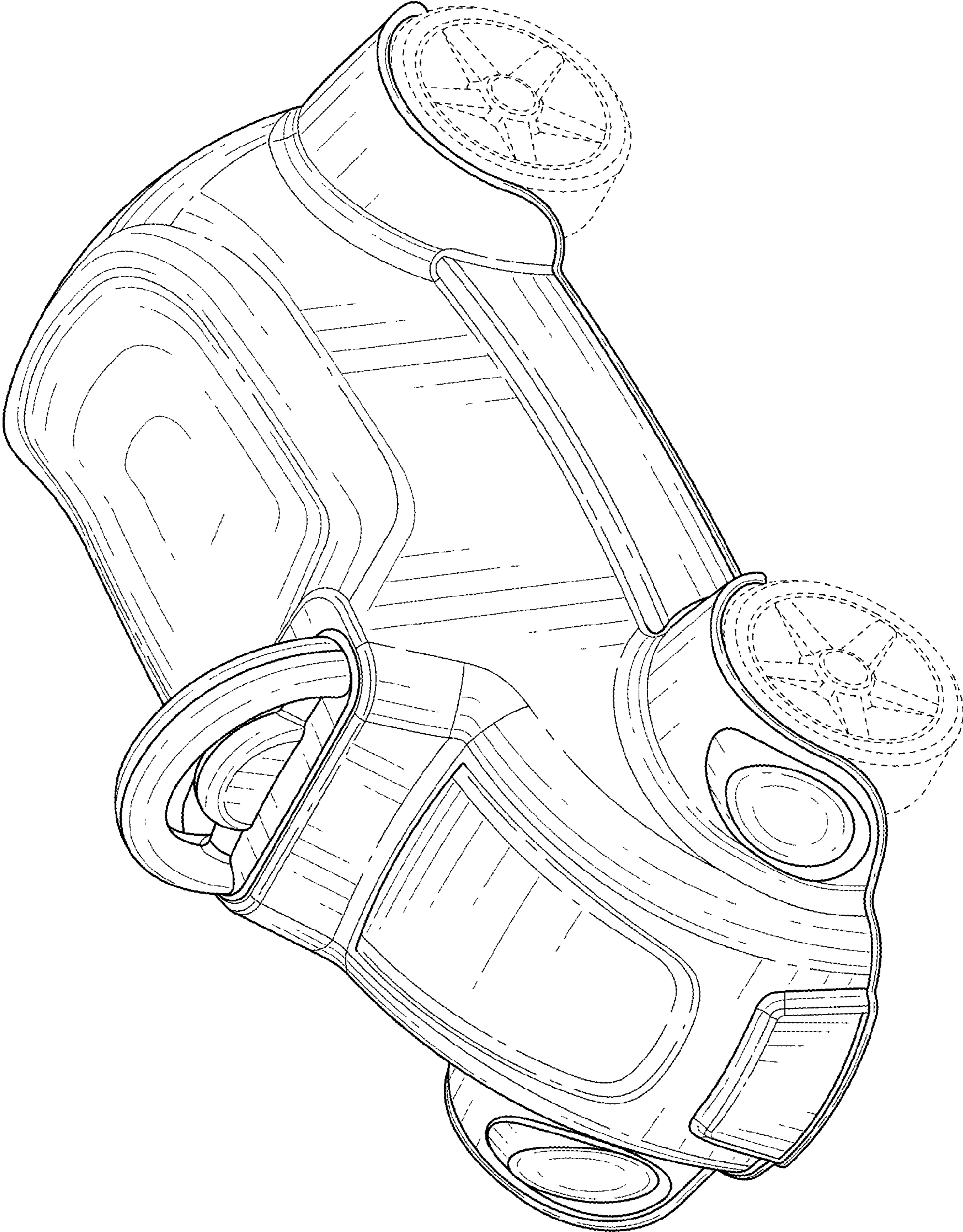

FIG. 1

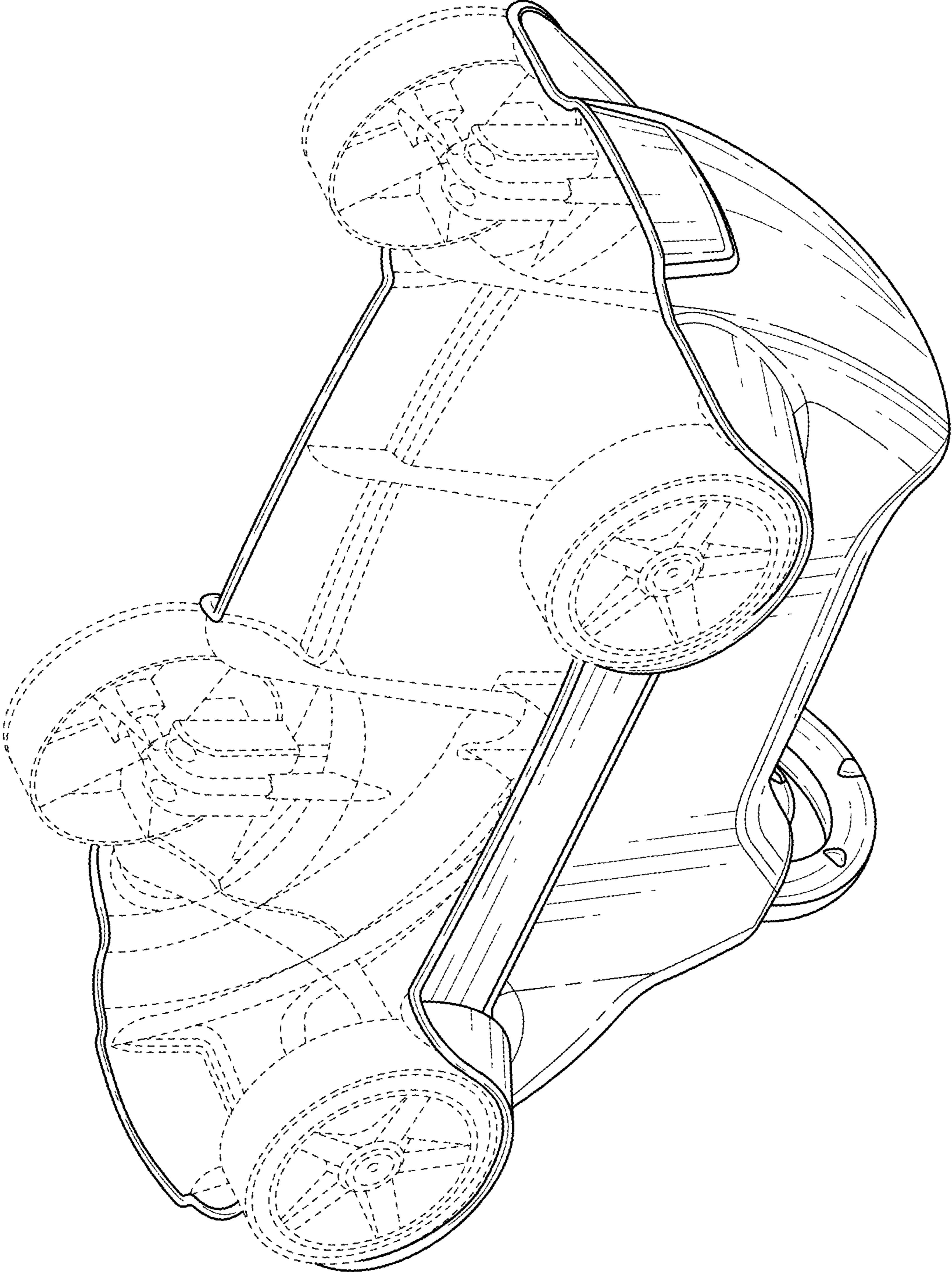

FIG. 2

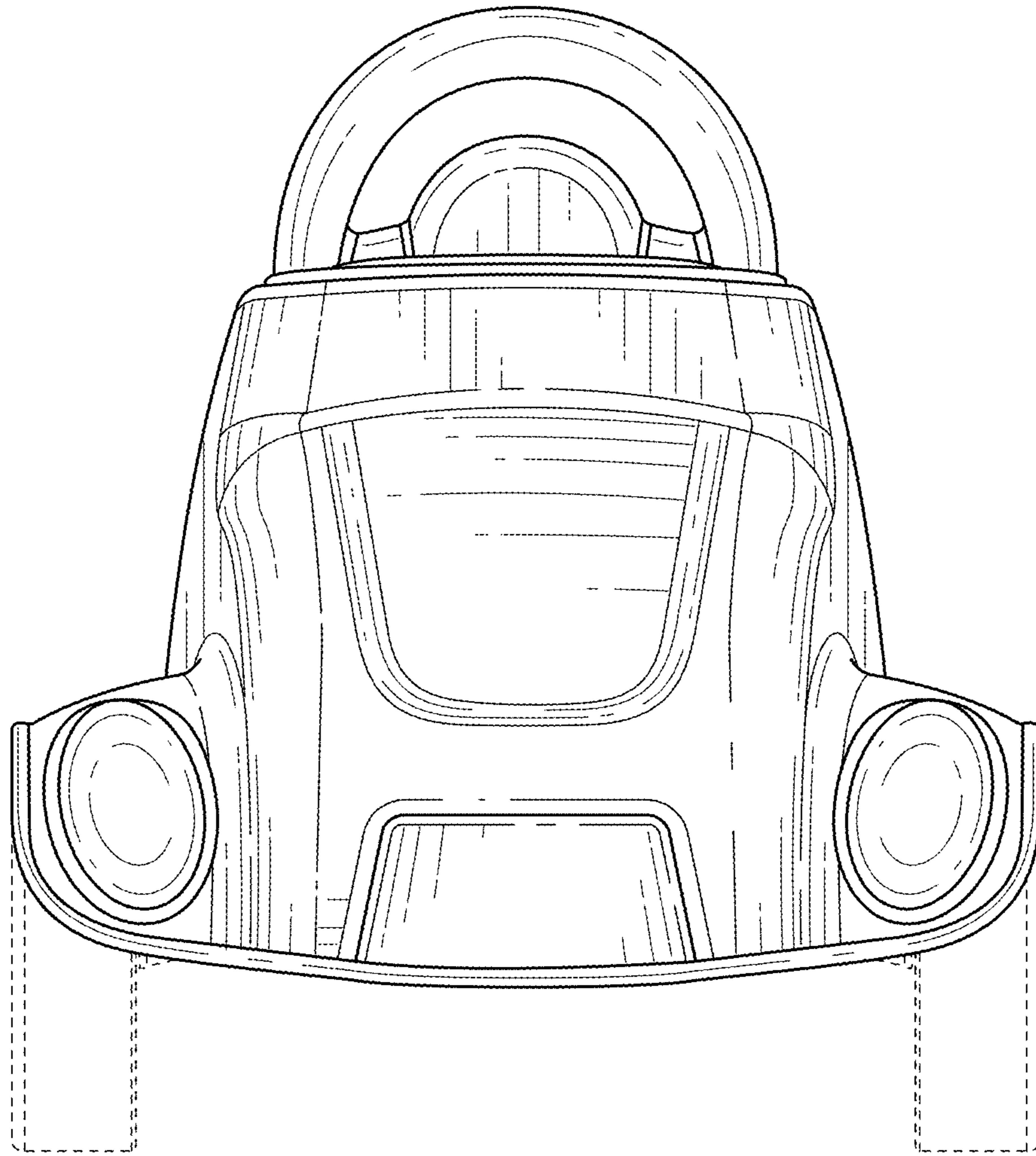

FIG. 3

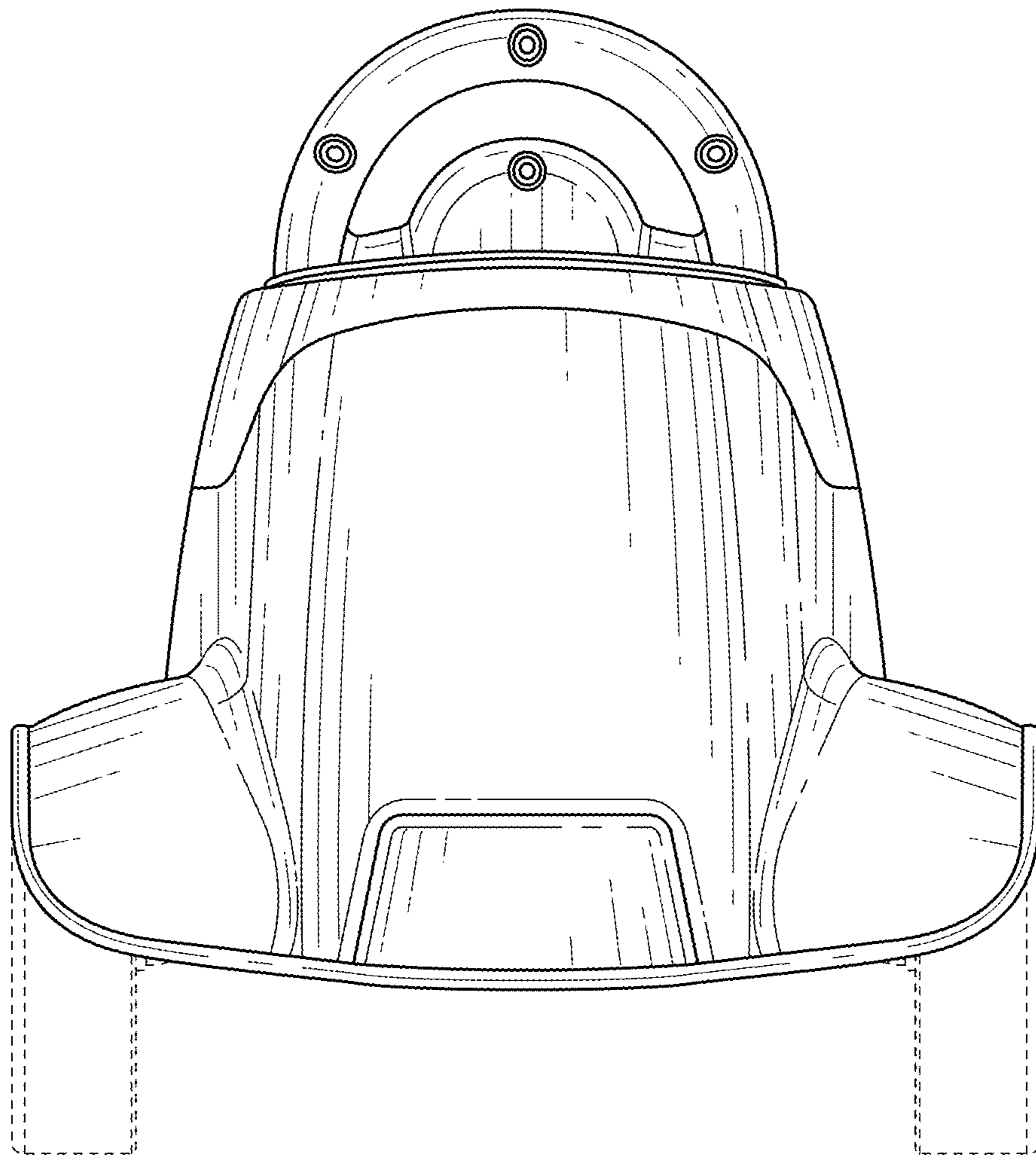

FIG. 4

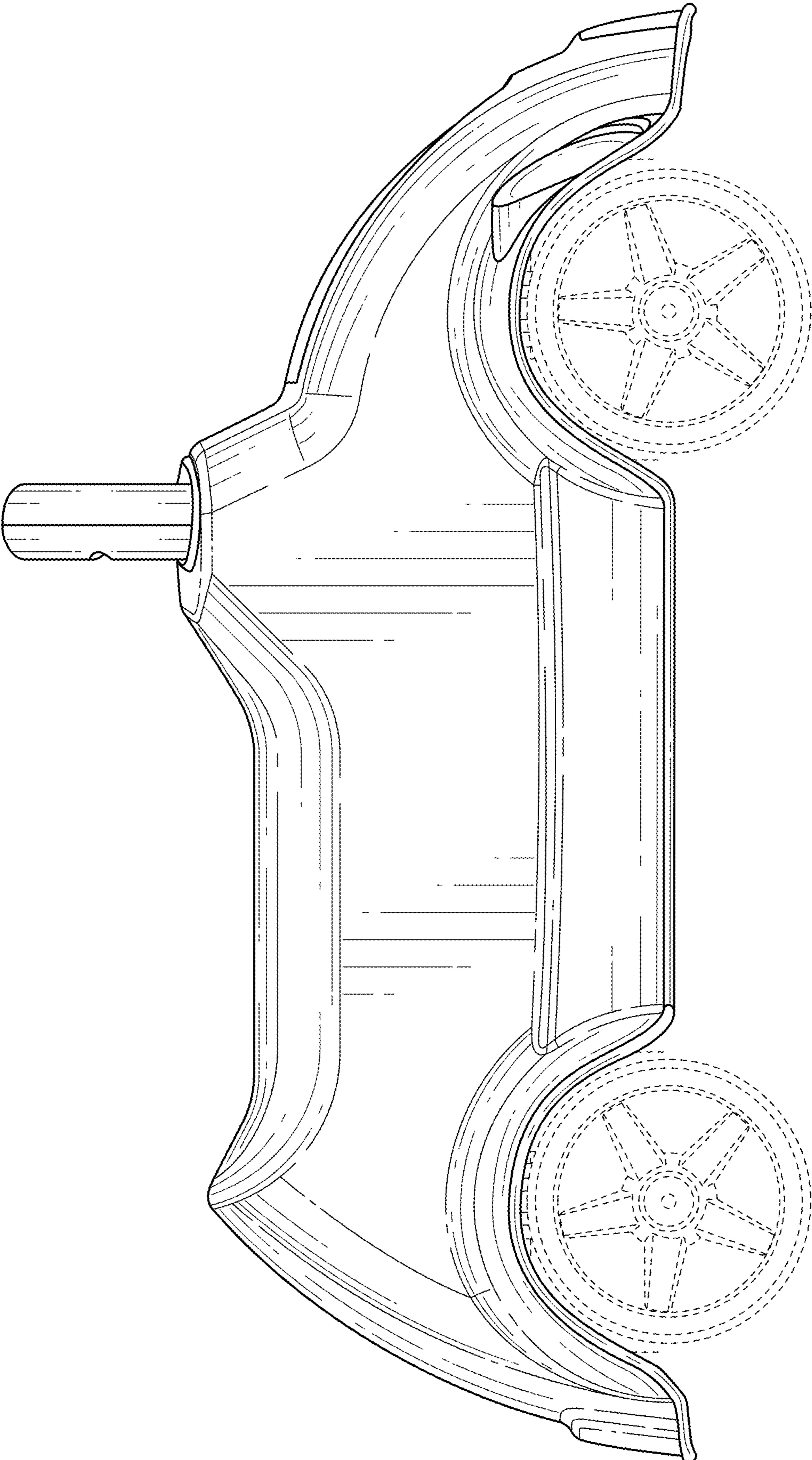

FIG. 5

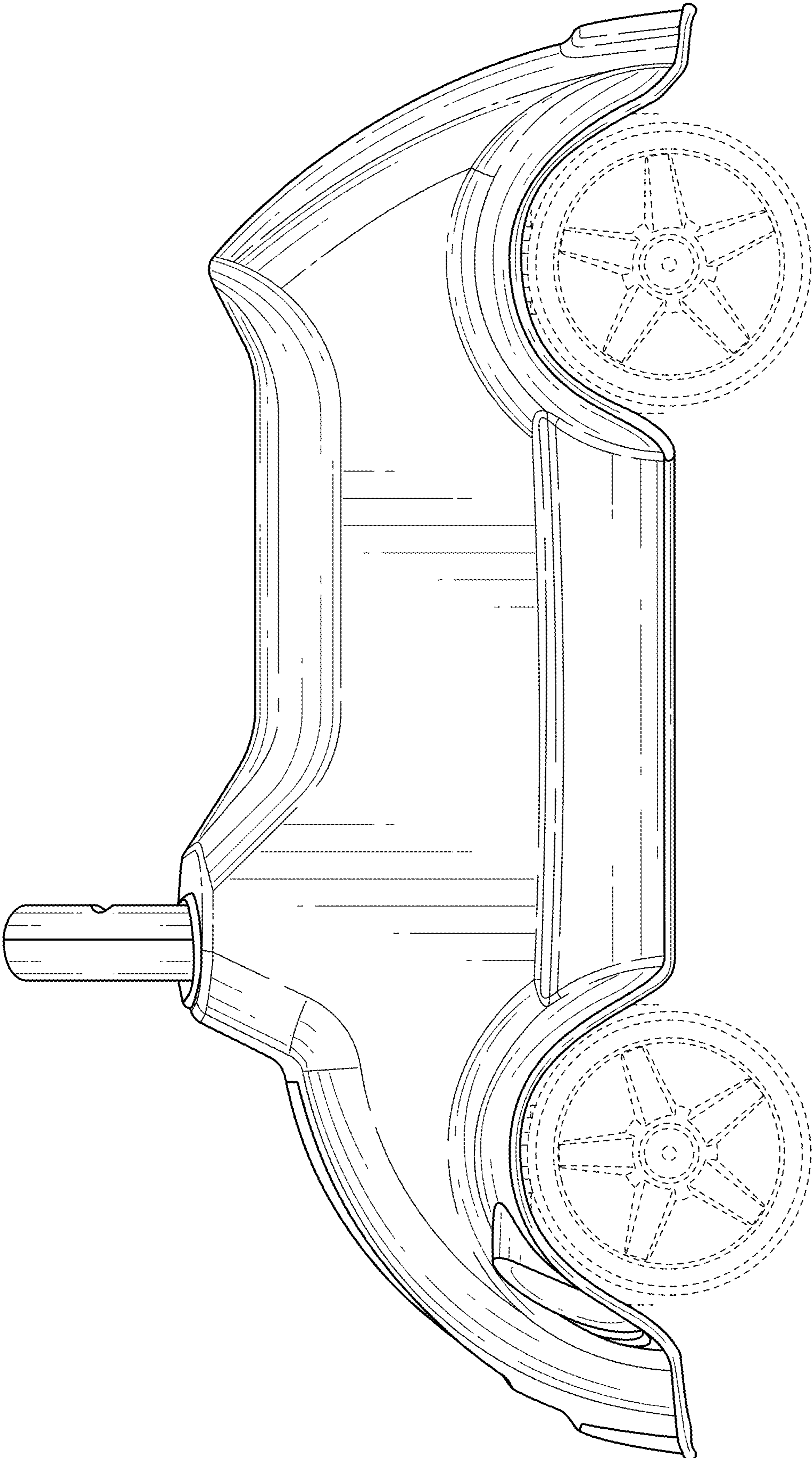

FIG. 6

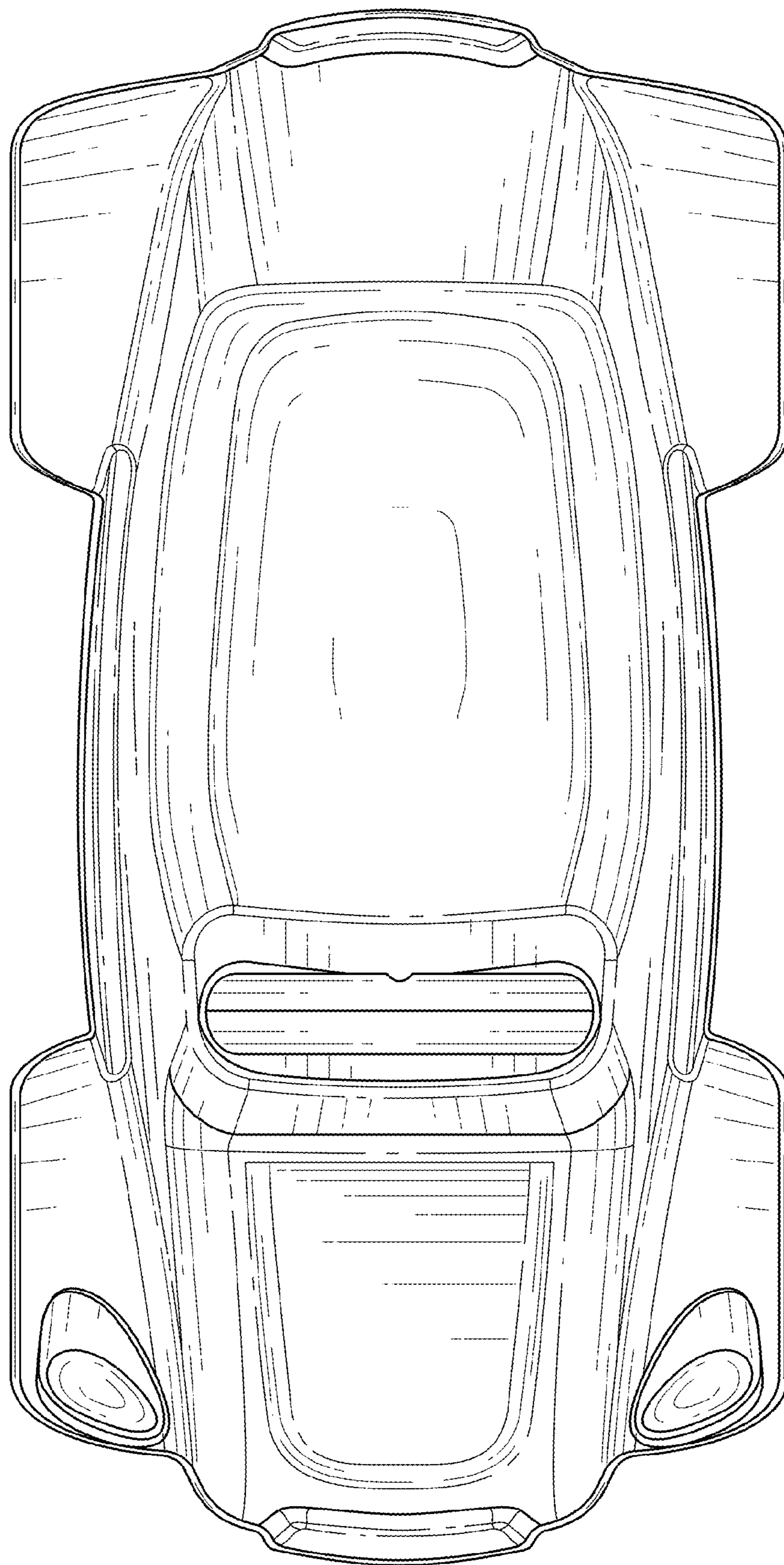

FIG. 7

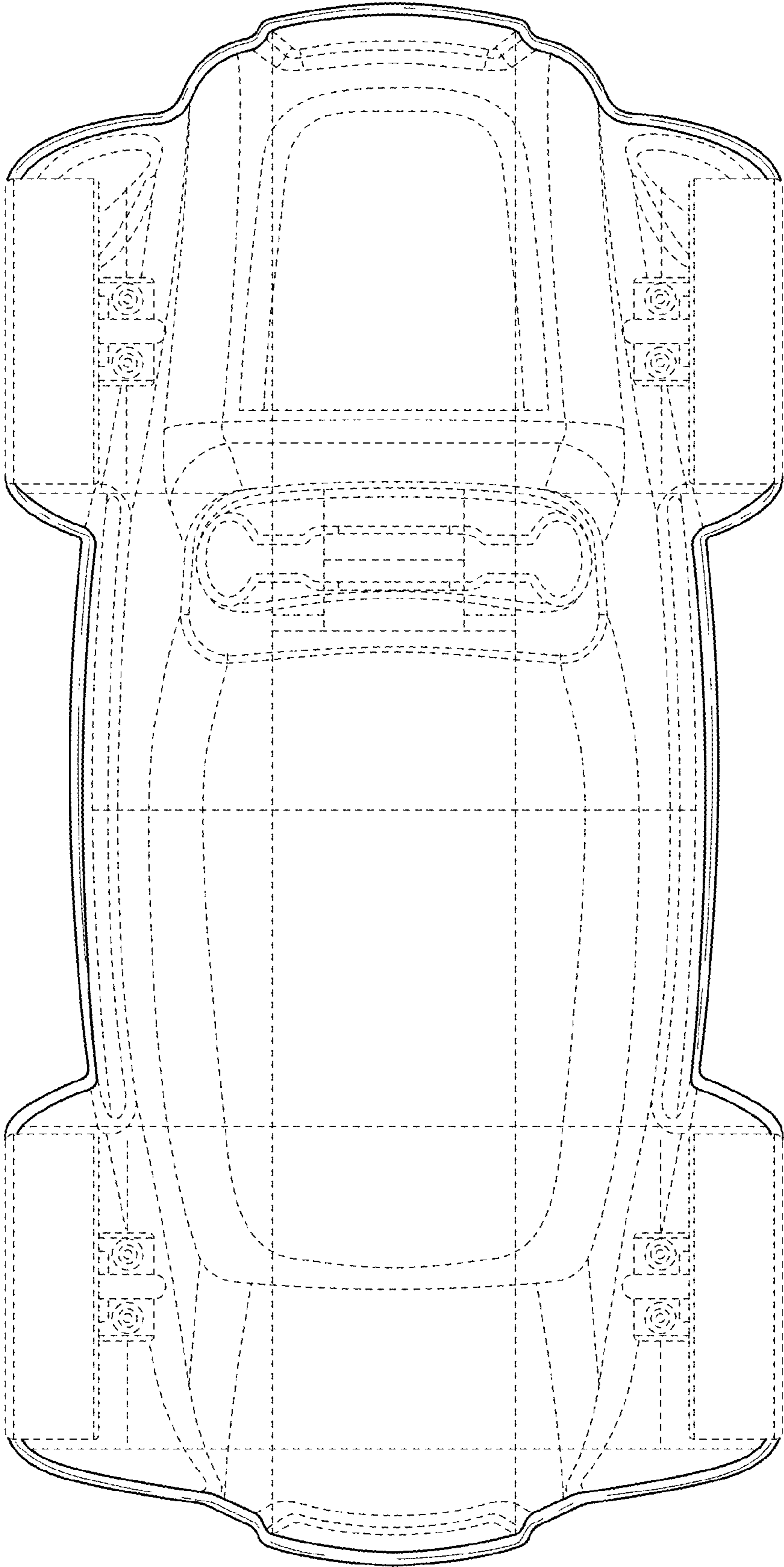

FIG. 8