



US00D916147S

(12) **United States Design Patent** (10) **Patent No.:** **US D916,147 S**
Sbabo (45) **Date of Patent:** **** *Apr. 13, 2021**

(54) **3-D PRINTER**

(71) Applicant: **SISMA S.p.A.**, Piovene Rocchette (IT)

(72) Inventor: **Alessandro Sbabo**, Schio (IT)

(73) Assignee: **SISMA S.P.A.**, Piovene Rocchette (IT)

(*) Notice: This patent is subject to a terminal disclaimer.

(**) Term: **15 Years**

(21) Appl. No.: **29/695,473**

(22) Filed: **Jun. 19, 2019**

(30) **Foreign Application Priority Data**

Mar. 14, 2019 (EM) 006308615

(51) **LOC (13) Cl.** **15-09**

(52) **U.S. Cl.**
USPC **D15/122**

(58) **Field of Classification Search**

USPC D15/122, 135; D7/323, 346; D18/53,
D18/39; D24/163, 219

CPC B29C 64/20; B29C 64/25; B29C 64/118;
B29C 64/255; B29C 64/336; B29C
64/386; B29C 64/209; B33Y 30/00;
B33Y 10/00; B33Y 99/00

See application file for complete search history.

(56) **References Cited**

U.S. PATENT DOCUMENTS

D244,200 S *	5/1977	Ramos	D23/369
D293,366 S *	12/1987	O'Neil, Jr.	D23/366
D597,192 S *	7/2009	Drucker	D23/366
D722,108 S *	2/2015	Reches	D18/50
D776,174 S *	1/2017	Summit	D15/122

(Continued)

OTHER PUBLICATIONS

SISMA, Everes Zero, (published Jun. 2019), SISMA brochure from website, URL:<https://www.3d.sisma.com/3d-resina-everes-uno?lang=en> (Year: 2019).*

(Continued)

Primary Examiner — Sheryl Lane

Assistant Examiner — Mark T. Philipps

(74) *Attorney, Agent, or Firm* — Knobbe, Martens, Olson & Bear, LLP

(57) **CLAIM**

The ornamental design for a 3-D printer, as shown and described.

DESCRIPTION

FIG. 1 is a perspective view of a 3-D printer with a front doorway open, showing my new design;

FIG. 2 is a front view thereof;

FIG. 3 is a rear view thereof;

FIG. 4 is a left side view thereof;

FIG. 5 is a right side view thereof;

FIG. 6 is a top view thereof;

FIG. 7 is a bottom view thereof;

FIG. 8 is a perspective view of the 3-D printer with the front doorway closed;

FIG. 9 is a front view thereof;

FIG. 10 is a rear view thereof;

FIG. 11 is a left side view thereof;

FIG. 12 is a right side view thereof;

FIG. 13 is a top view thereof; and,

FIG. 14 is a bottom view thereof.

The views include three types of stippled shading to show surface contrast between different portions of the 3-D printer, including one or more of color contrast, texture contrast, or the like. For example, stippled shading on the inner ring on top of the 3-D printer can indicate different color than the rest of the 3-D printer.

The broken lines in the views illustrate portions of the 3-D printer that form no part of the claimed design.

1 Claim, 14 Drawing Sheets

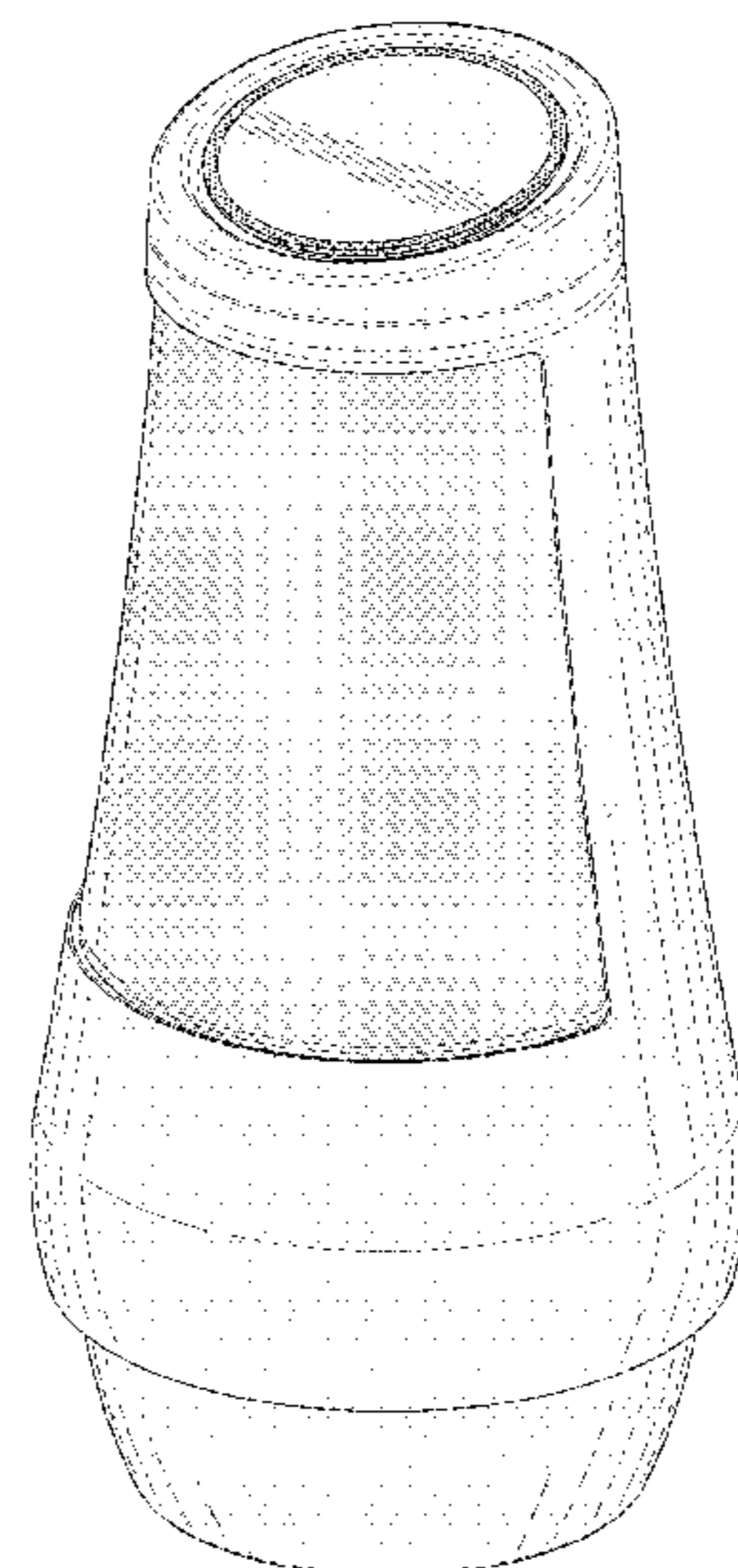
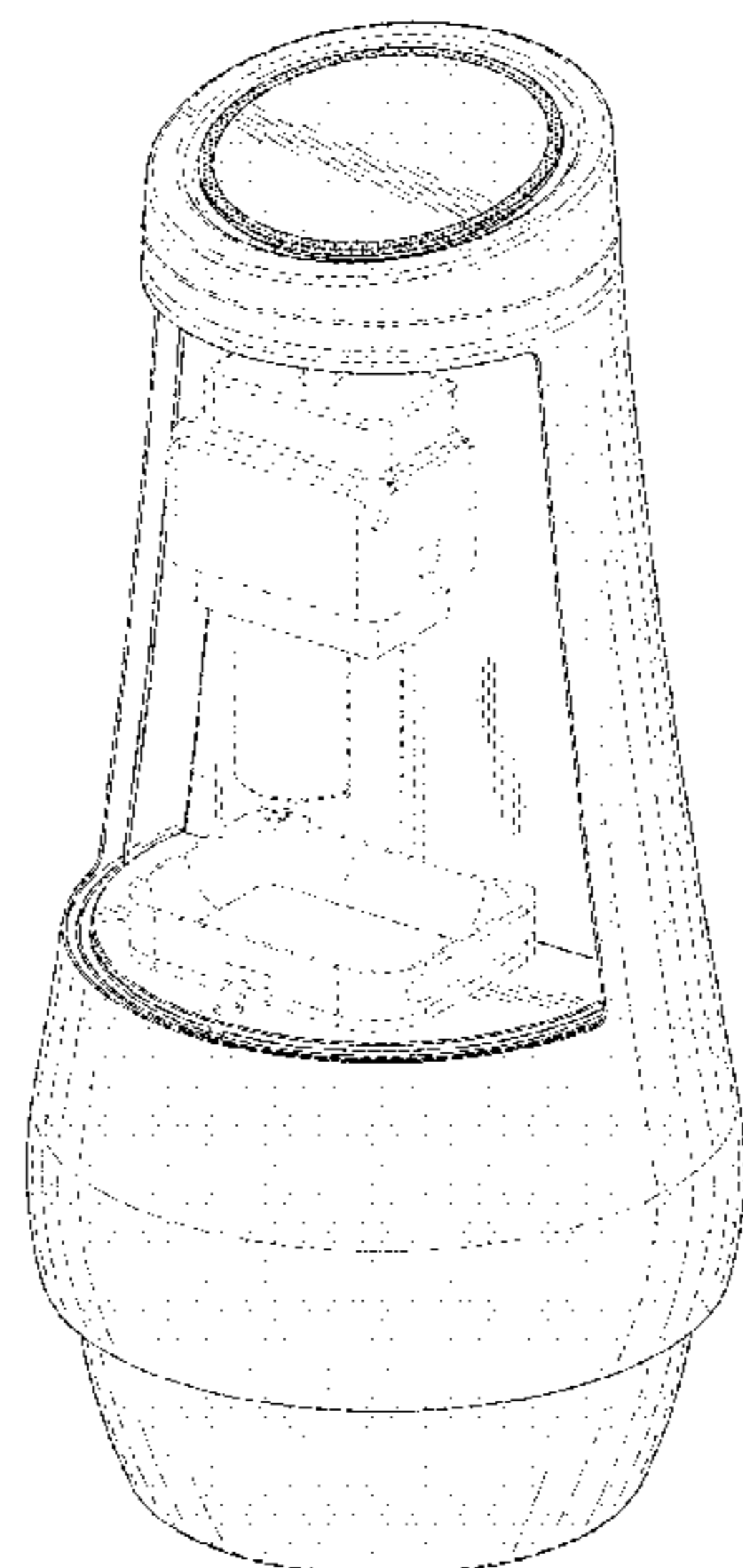

(56)

References Cited

U.S. PATENT DOCUMENTS

D819,821 S * 6/2018 Yamanaka D24/163
D828,530 S * 9/2018 Brandenburg D23/366
D871,463 S * 12/2019 Cao D15/122
D879,850 S * 3/2020 Wolf D15/199
D886,167 S * 6/2020 Wang D15/122
D892,875 S * 8/2020 Medalsy D15/122
2010/0096489 A1 * 4/2010 Taatjes B29C 64/106
242/520
2014/0085620 A1 * 3/2014 Lobovsky B33Y 40/00
355/72
2015/0283763 A1 * 10/2015 Chi B29C 64/386
700/119
2016/0136893 A1 * 5/2016 Chang B29C 64/209
425/150
2016/0193784 A1 * 7/2016 Tadin B29C 64/25
425/375
2018/0354196 A1 * 12/2018 Wu B33Y 50/02
2020/0307070 A1 * 10/2020 Swanson B29C 64/336

OTHER PUBLICATIONS

FlashForge, Adventurer 3 Lite FDM 3D Printer, (first available Jan. 14, 2019), Amazon.com, URL:<<https://www.amazon.com/FlashForge-Adventurer-Lite-FDM-Printer/dp/B07TYRGWSQ>> (Year: 2019).*

* cited by examiner

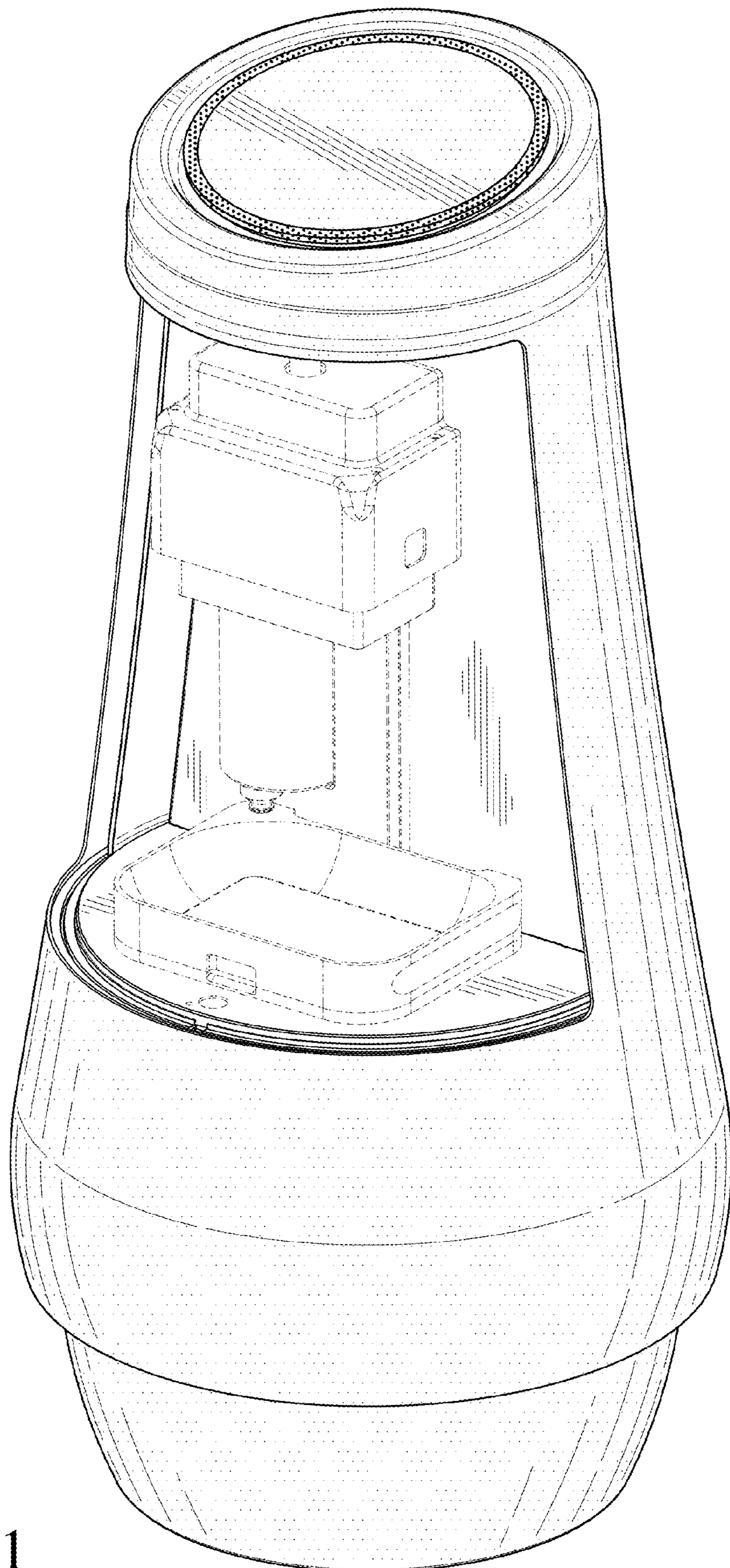

FIG. 1

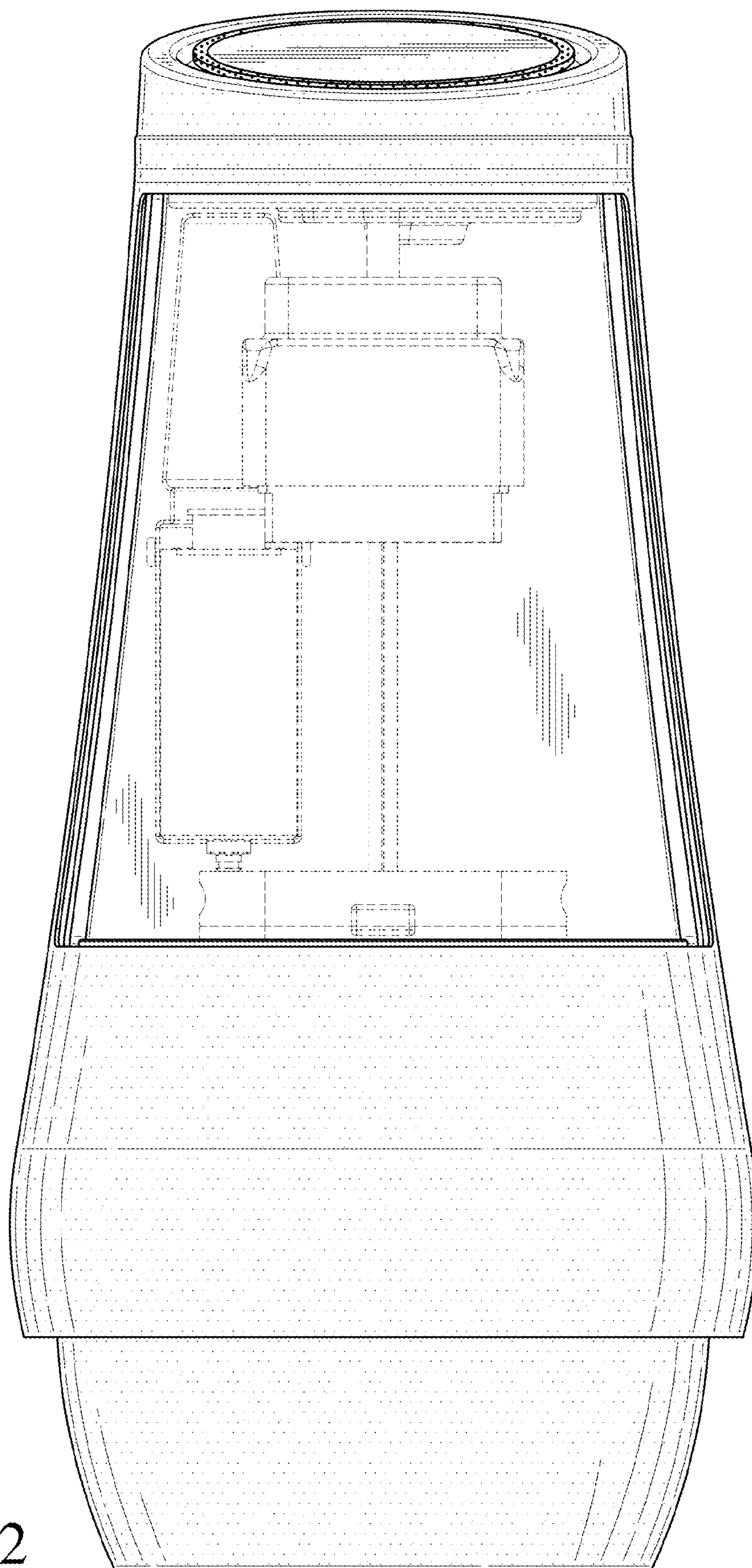

FIG. 2

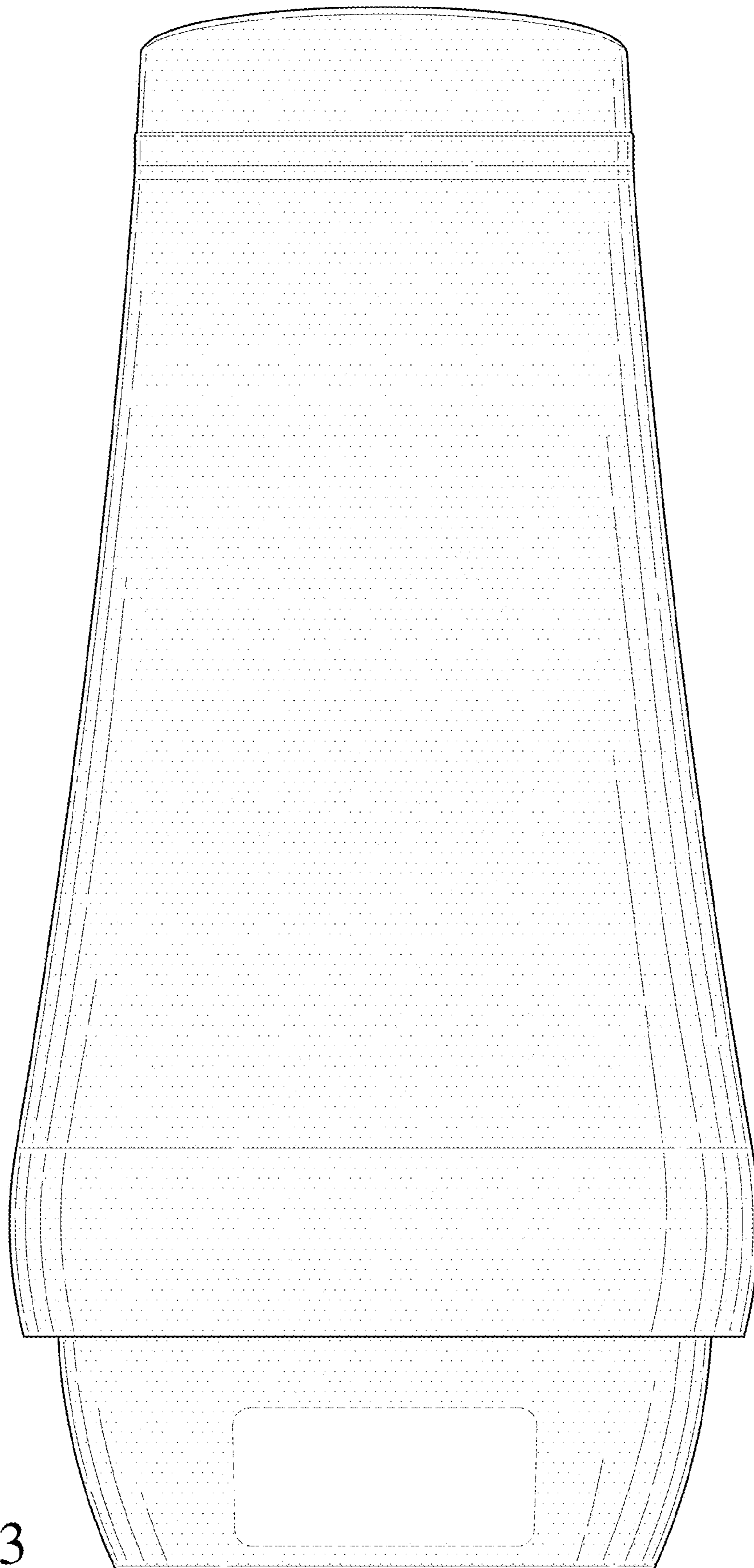

FIG. 3

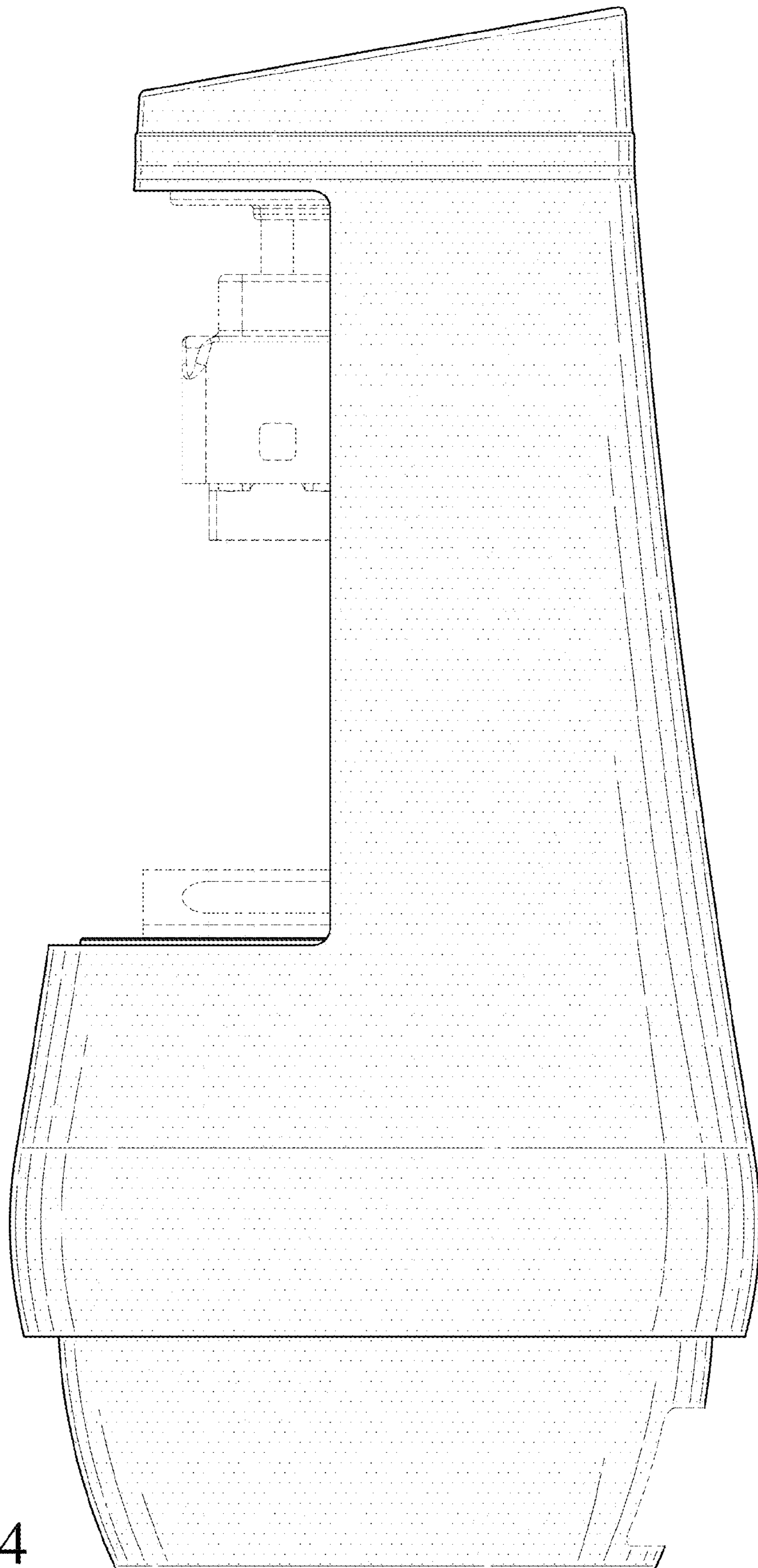

FIG. 4

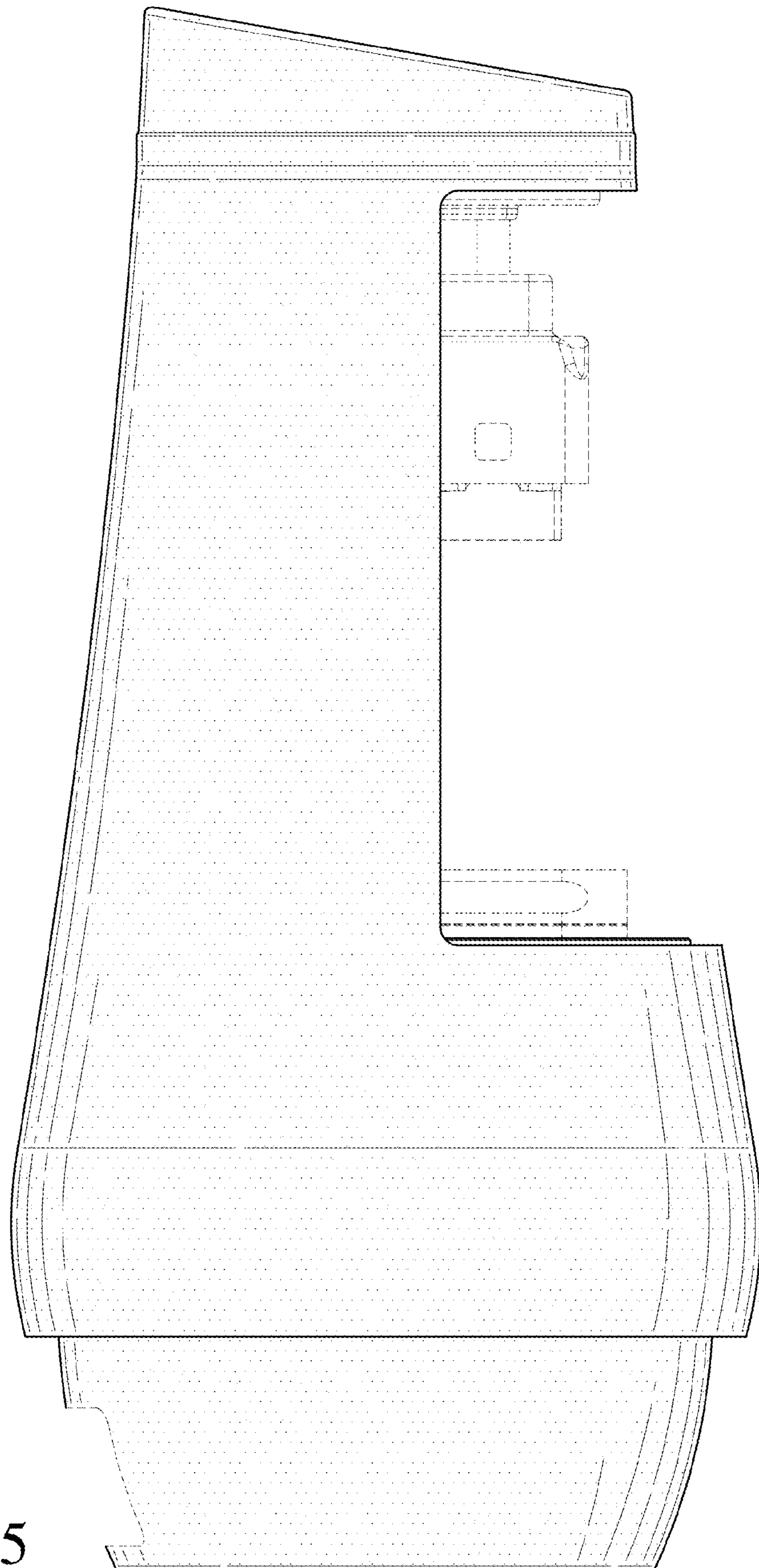

FIG. 5

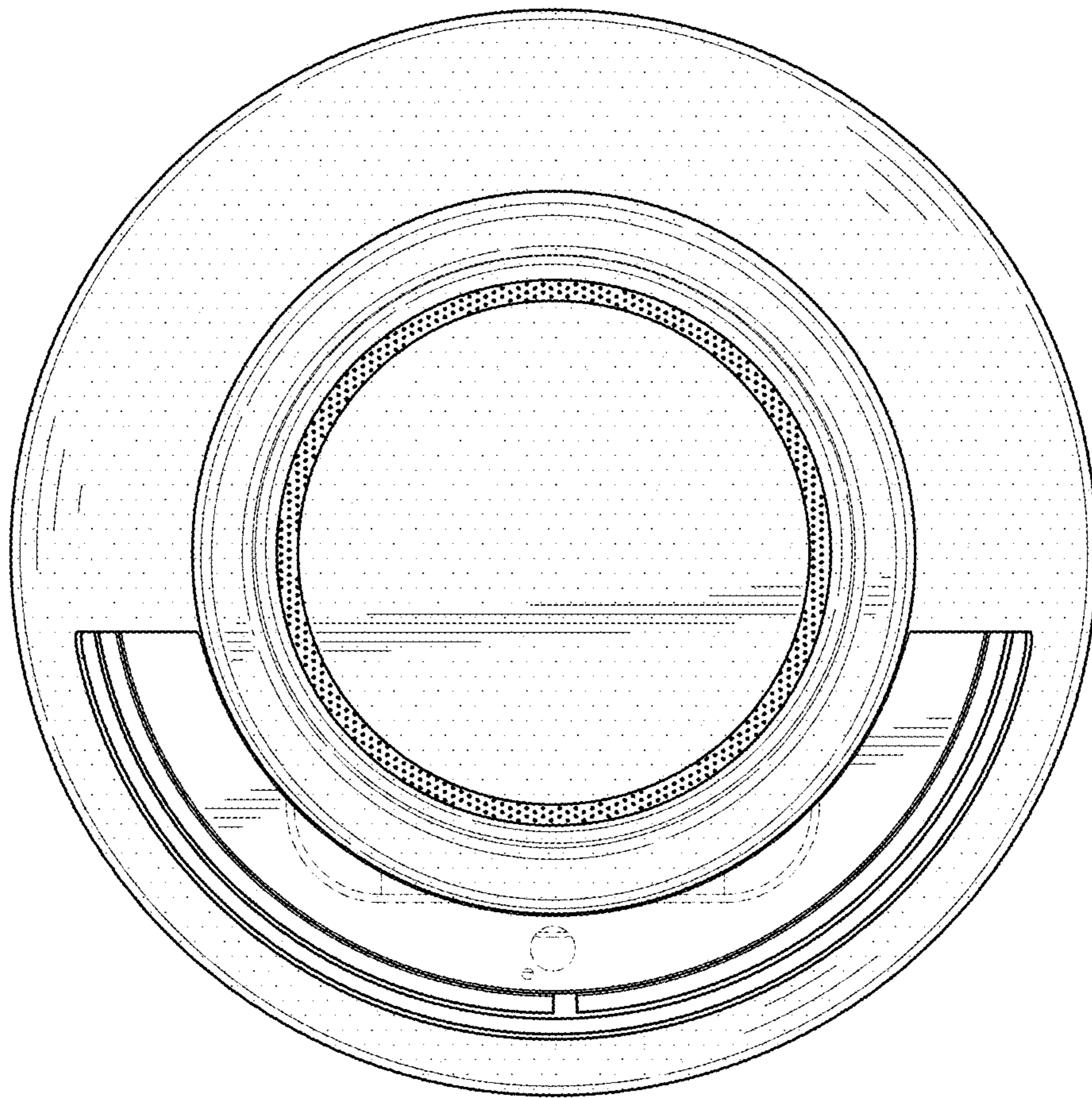

FIG. 6

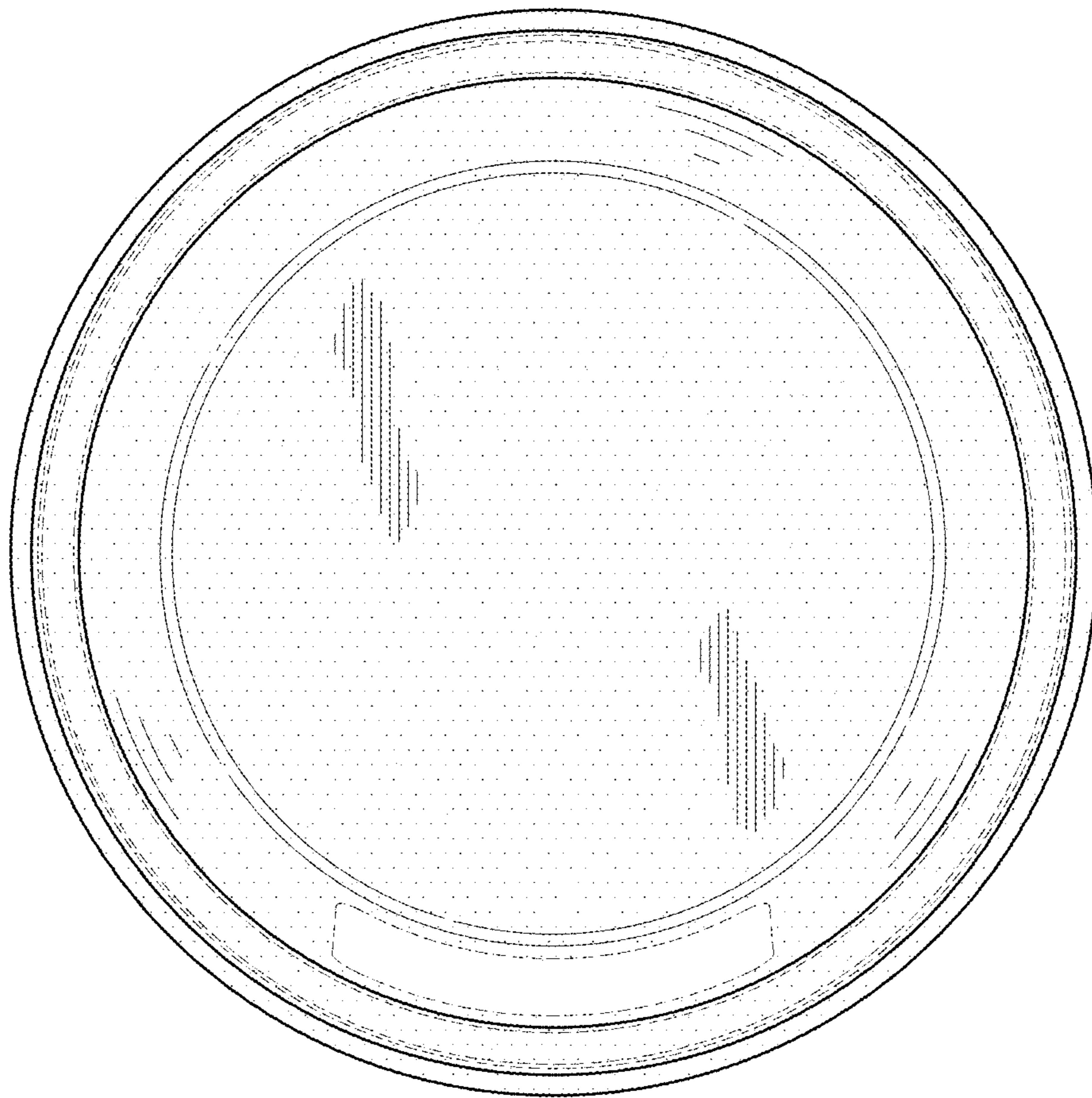

FIG. 7

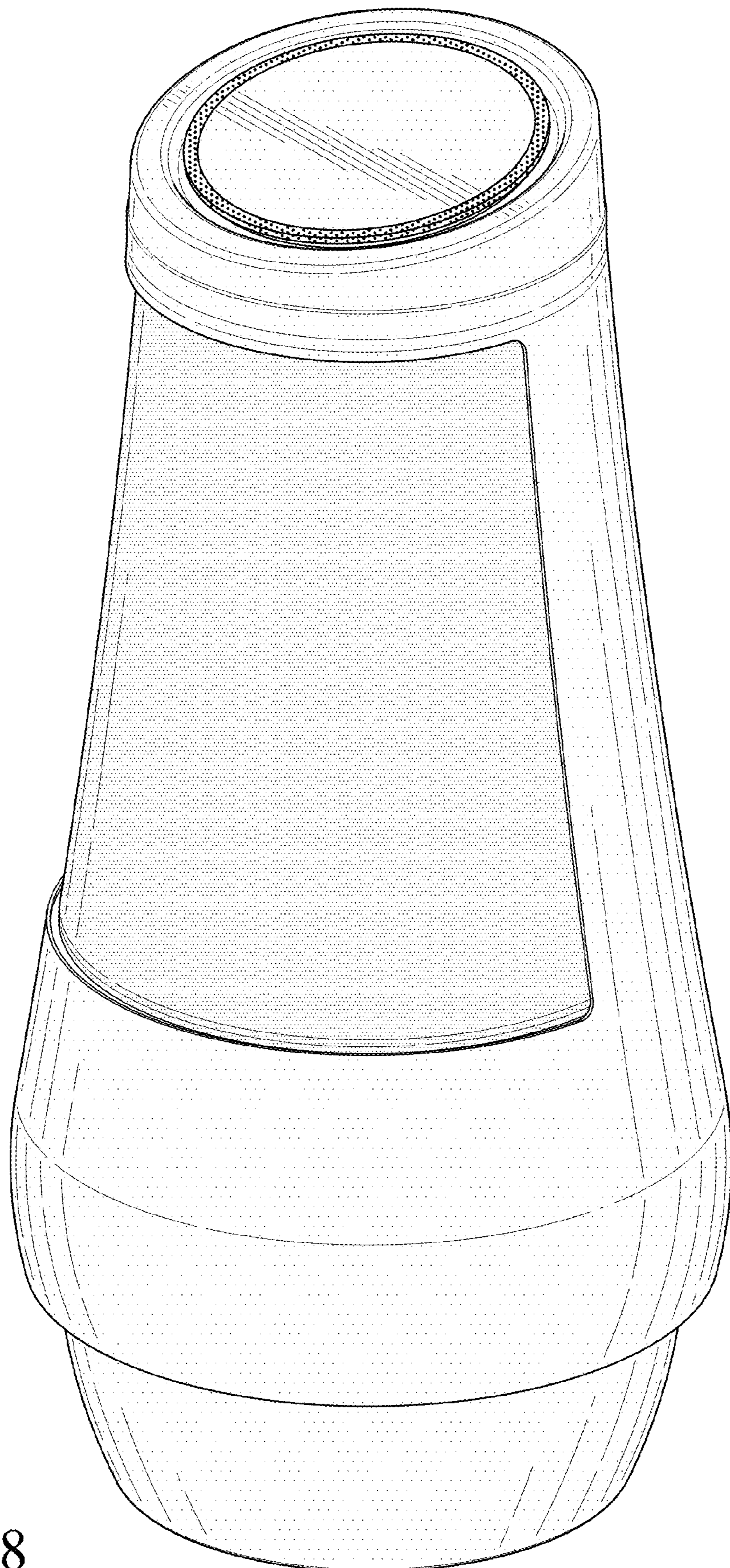

FIG. 8

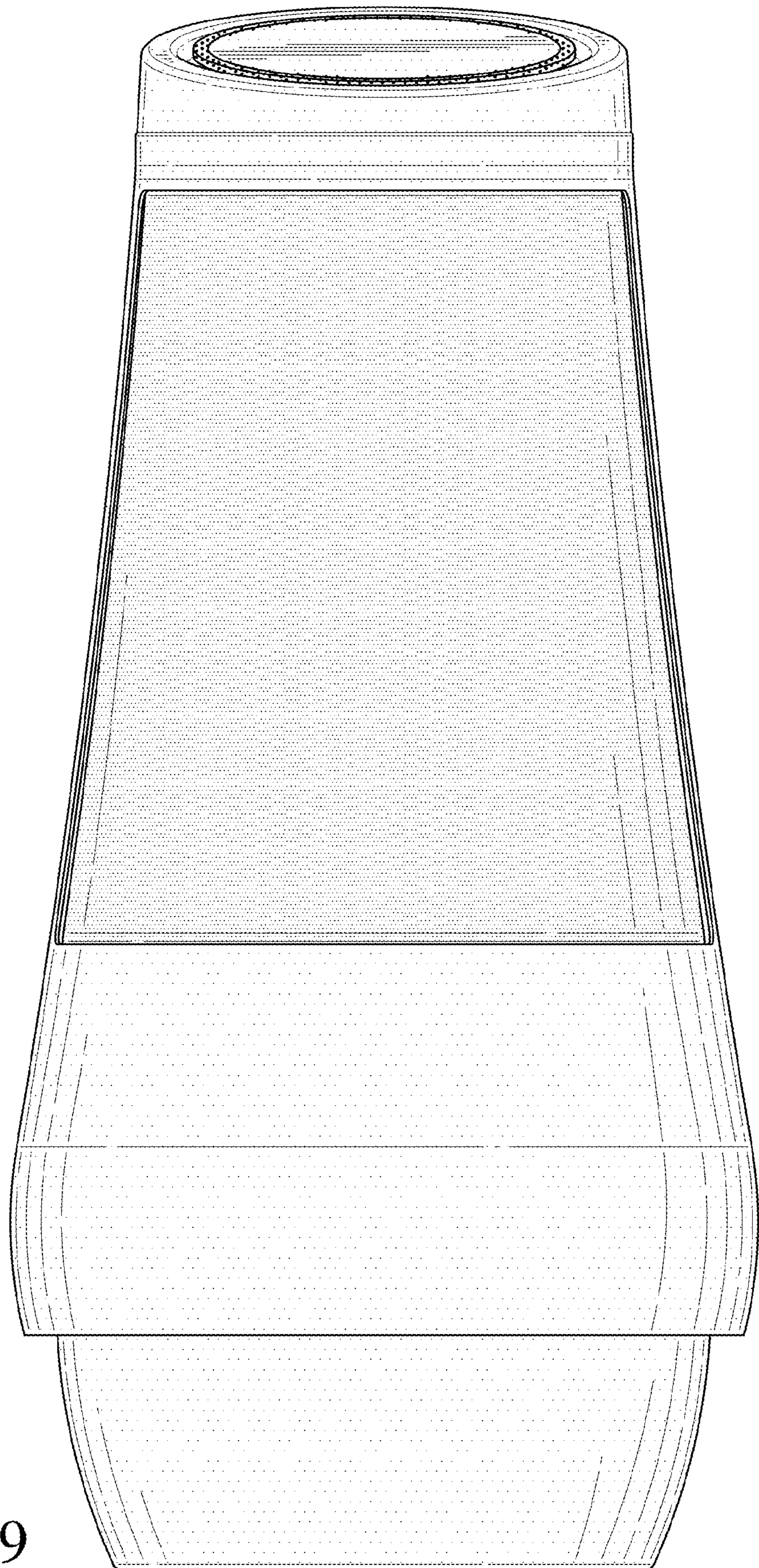

FIG. 9

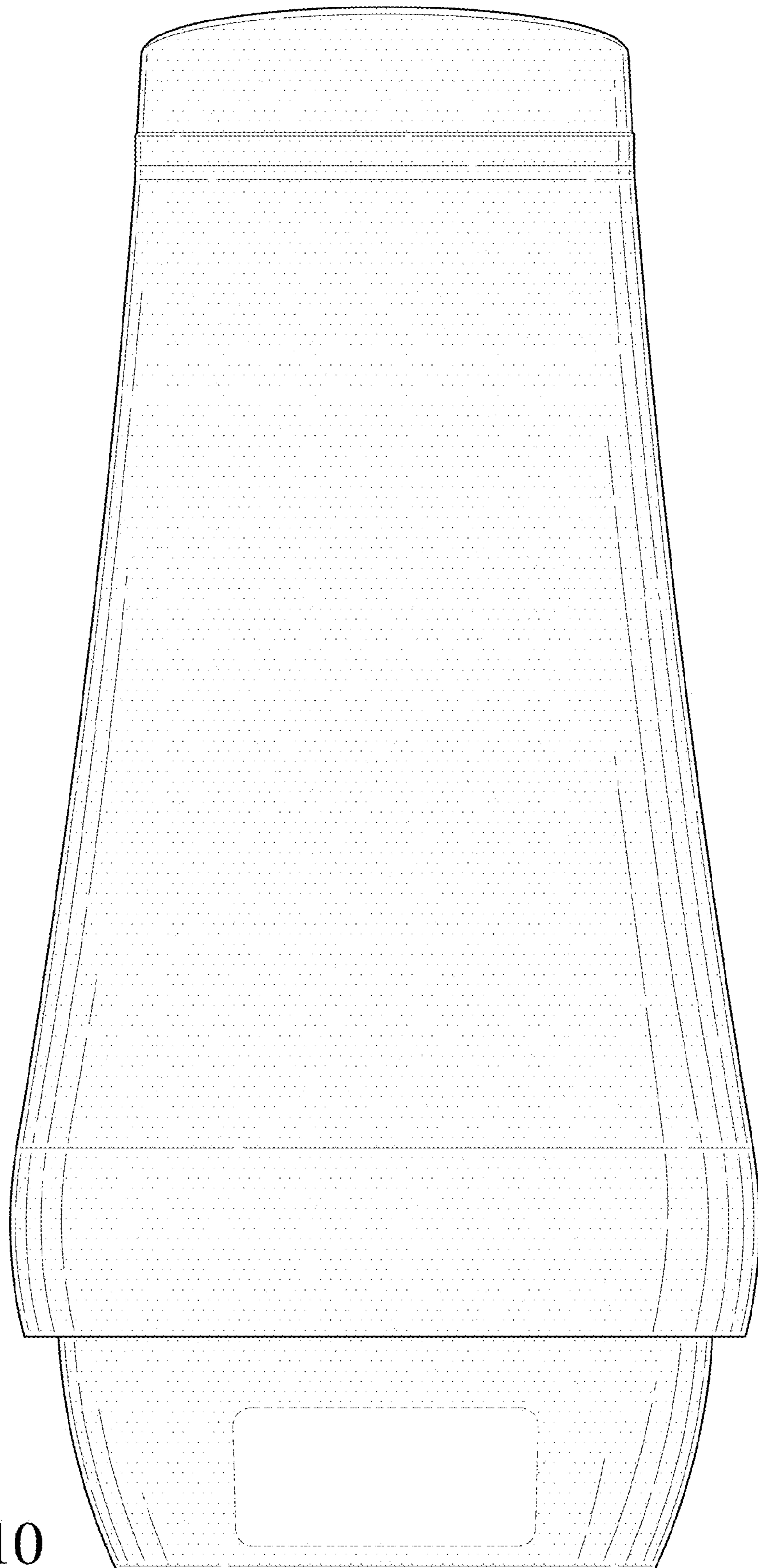

FIG. 10

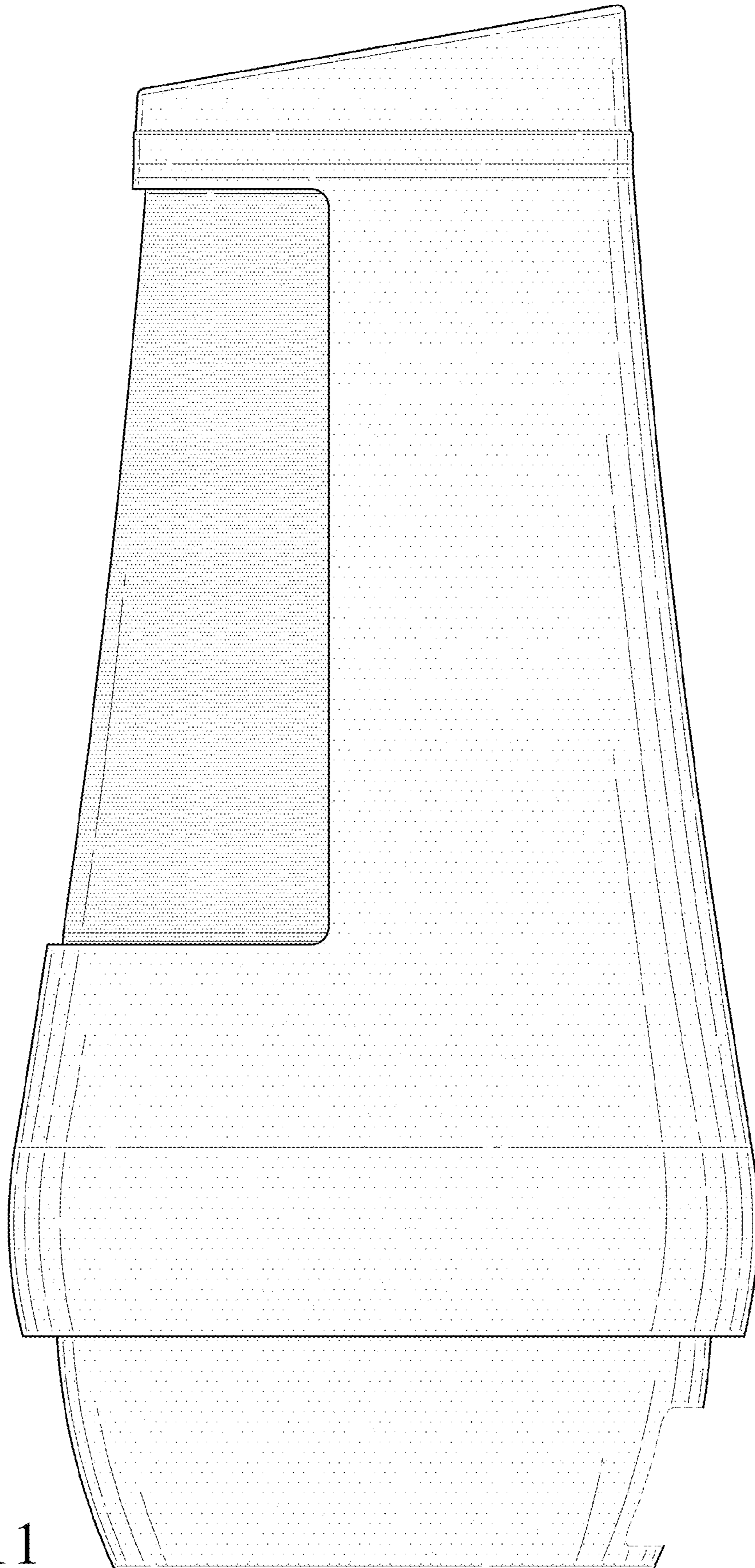

FIG. 11

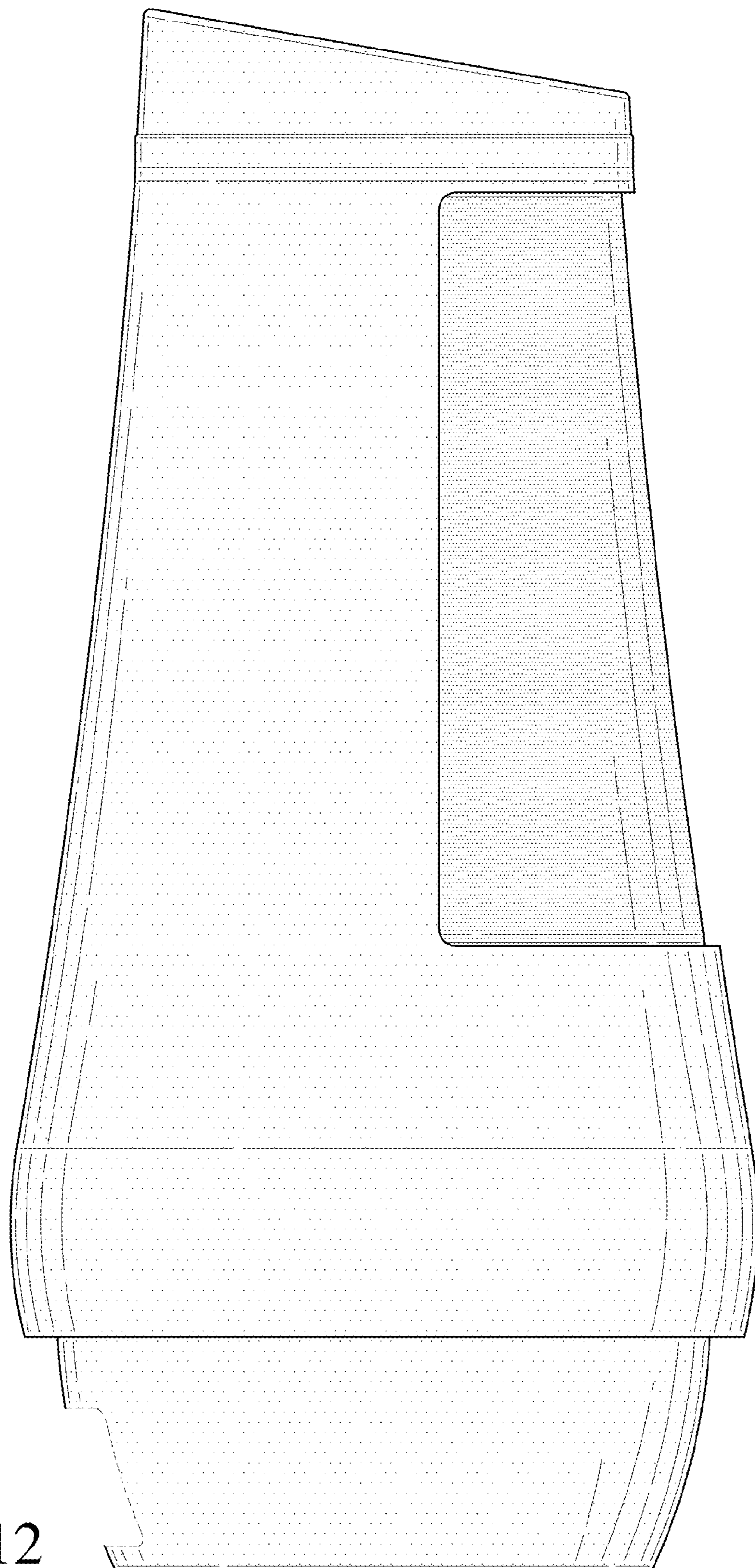

FIG. 12

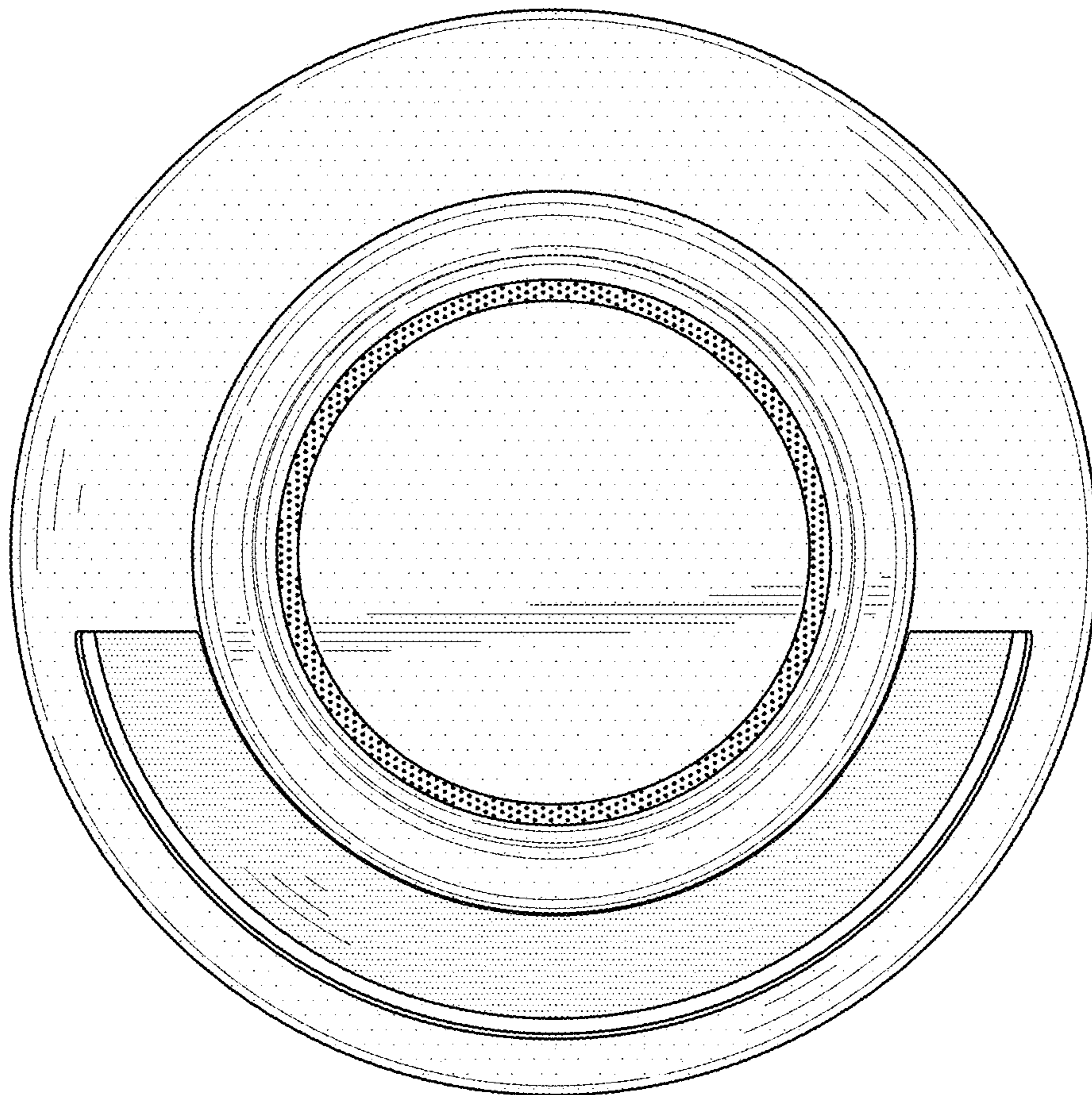

FIG. 13

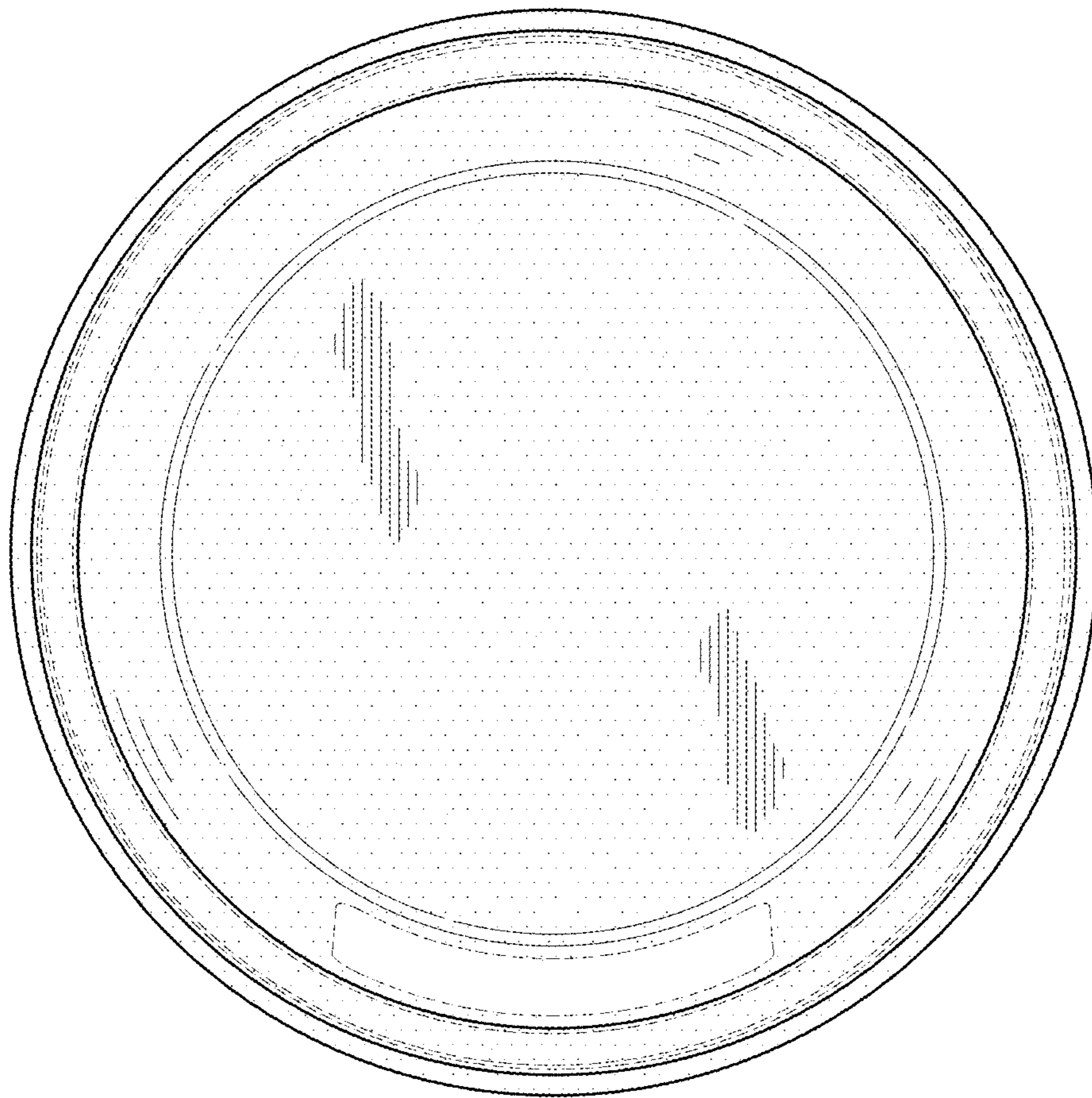

FIG. 14