



US00D915969S

(12) **United States Design Patent** (10) **Patent No.:** **US D915,969 S**
Pugliesi et al. (45) **Date of Patent:** **** Apr. 13, 2021**

(54) **MODULE FOR PASSENGER SERVICE UNIT**

(56) **References Cited**

(71) Applicant: **EMBRAER S.A.**, São José dos Campos-SP (BR)

U.S. PATENT DOCUMENTS

(72) Inventors: **Fernanda Loth Pugliesi**, São José dos Campos (BR); **Bruno Kimura Castanha**, São José dos Campos (BR); **Jay Beever**, São José dos Campos (BR); **Joshua Rea**, São José dos Campos (BR); **Rainer Bernd Zierer**, São José dos Campos (BR)

D794,523	S	*	8/2017	Pepin	D12/195
D807,265	S	*	1/2018	McNutt	D12/190
D811,969	S	*	3/2018	Sethapun	D12/192
D811,970	S	*	3/2018	Lokers	D12/195
D811,971	S	*	3/2018	Lokers	D12/195
D818,920	S	*	5/2018	Hodges	D12/195
D826,124	S	*	8/2018	Unveren	D12/195
D833,354	S	*	11/2018	Hodges	D12/195
2006/0037794	A1	*	2/2006	Riha	B60K 37/00 180/90
2018/0154743	A1	*	6/2018	Rao	B60R 13/0243

(73) Assignee: **EMBRAER S.A.**, São José dos Campos-SP (BR)

* cited by examiner

(**) Term: **15 Years**

Primary Examiner — Katrina A Betton

(21) Appl. No.: **29/692,136**

(74) *Attorney, Agent, or Firm* — Nixon & Vanderhye P.C.

(22) Filed: **May 22, 2019**

(57) **CLAIM**

The ornamental design for a “module for passenger service unit”, as shown and described.

Related U.S. Application Data

(62) Division of application No. 29/619,503, filed on Sep. 29, 2017, now Pat. No. Des. 858,392.

DESCRIPTION

(51) **LOC (13) Cl.** **12-16**

(52) **U.S. Cl.**
USPC **D12/195**

(58) **Field of Classification Search**
USPC D12/195, 193, 414, 190, 196; D15/17, D15/28; D10/46, 98, 102–103; D8/302–303
CPC B60J 5/04; B62D 31/02
See application file for complete search history.

FIG. 1 is a perspective view of our new and original design for a module for passenger service unit, FIG. 2 is a left end elevation view thereof; FIG. 3 is a right end elevation view thereof; FIG. 4 is a left side elevation view thereof; FIG. 5 is a right side elevation view thereof; FIG. 6 is a top plan view thereof; and, FIG. 7 is a bottom plan view thereof.

1 Claim, 4 Drawing Sheets

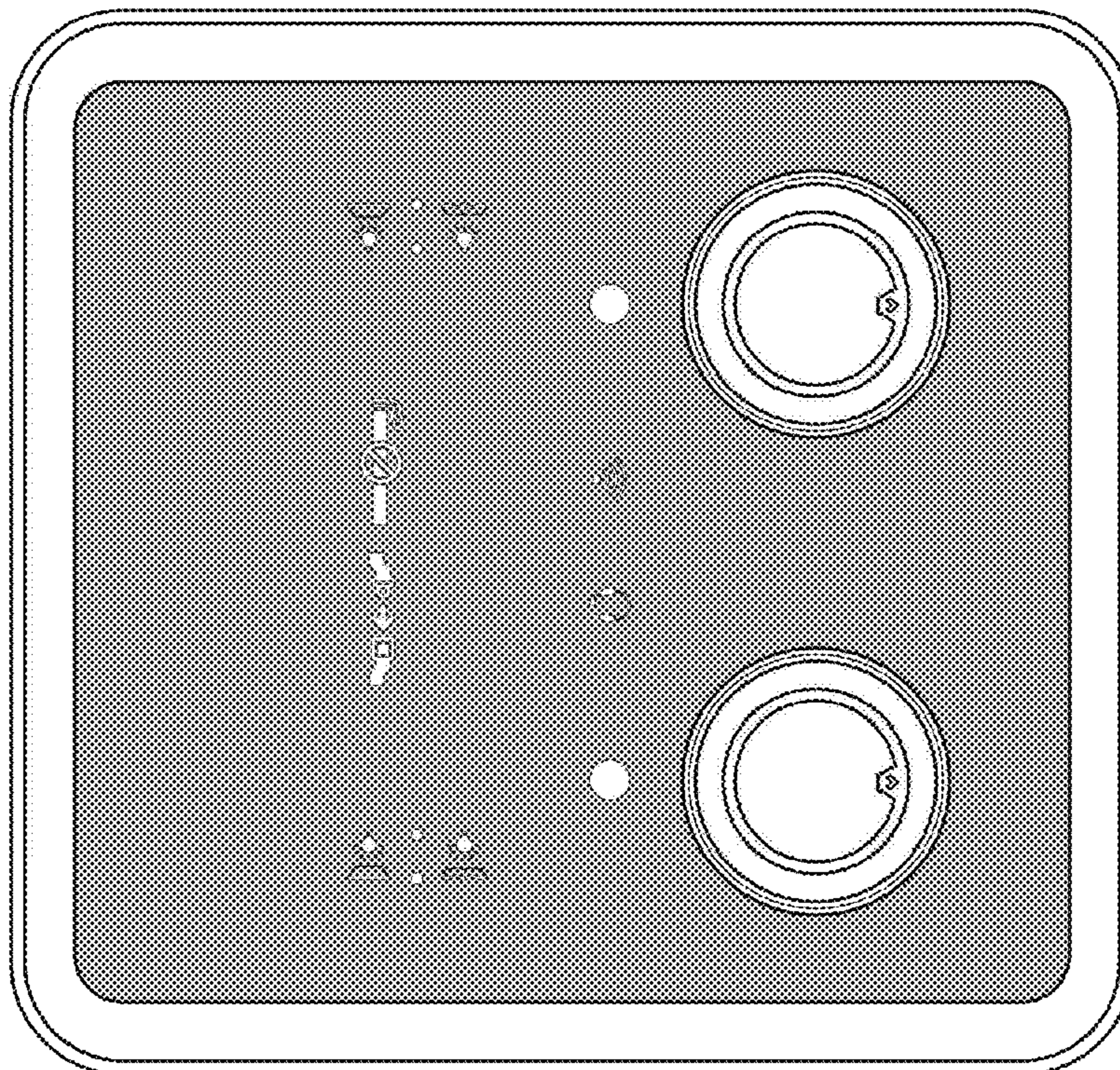

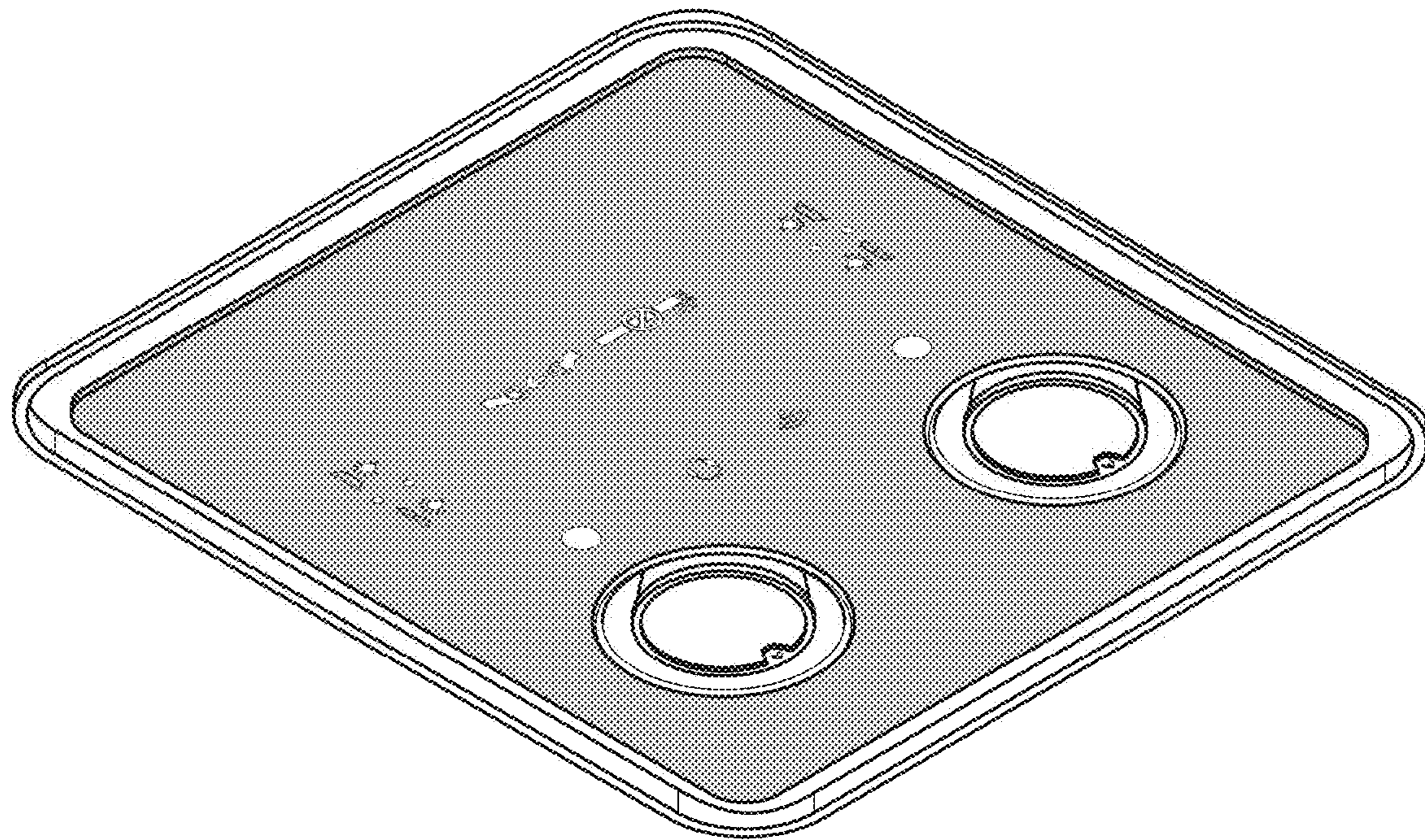

FIG. 1

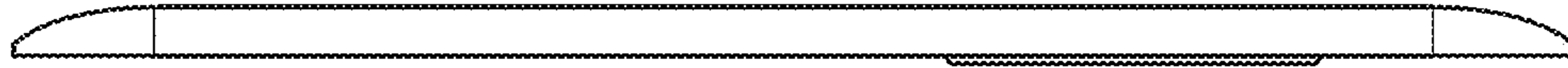

FIG. 2



FIG. 3

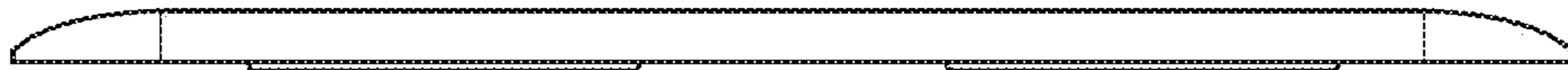

FIG. 4

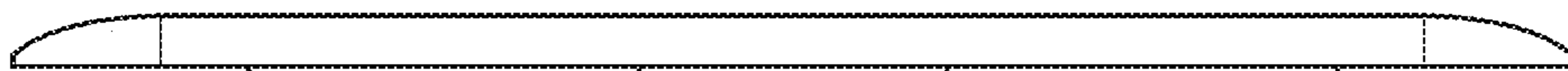

FIG. 5

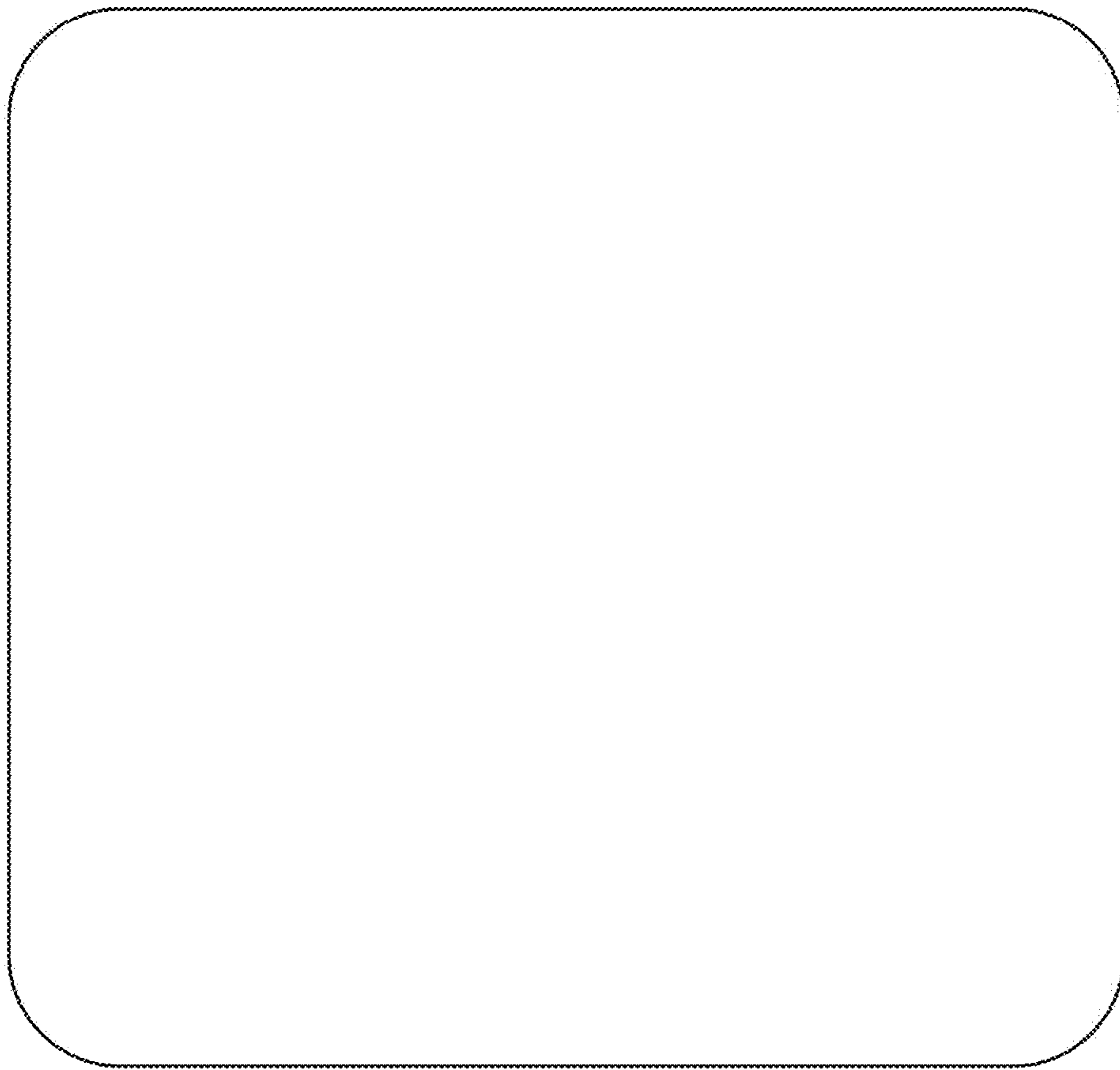

FIG. 6

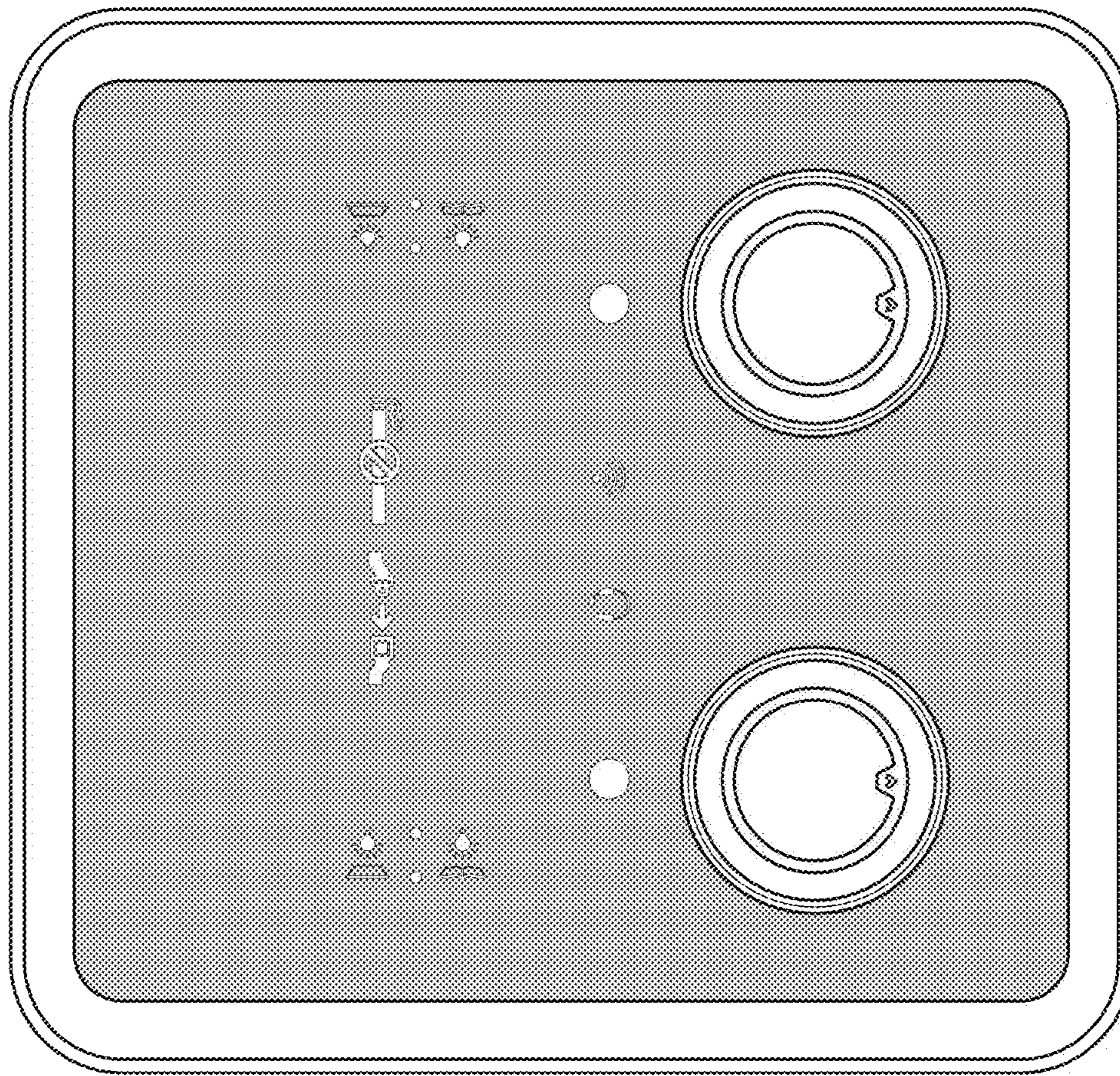

FIG. 7