



US00D915633S

(12) **United States Design Patent** (10) **Patent No.:** **US D915,633 S**  
**Patterson** (45) **Date of Patent:** **\*\* Apr. 6, 2021**

(54) **BAFFLE**

(56) **References Cited**

(71) Applicant: **3FORM, LLC**, Salt Lake City, UT (US)

U.S. PATENT DOCUMENTS

(72) Inventor: **Caleb Patterson**, Seattle, WA (US)

D97,213 S	11/1869	Stone	
D101,033 S	3/1870	Glatthar et al.	
D101,034 S	3/1870	Glatthar et al.	
D136,518 S	3/1873	Hofstetter	
D166,671 S	8/1875	Jernigan	
1,335,613 A	3/1920	Selle	
1,963,218 A	6/1934	Wakefield	
D123,049 S	10/1940	Doane	
2,506,728 A	5/1950	McGrath	
2,525,556 A	10/1950	Marchisio	
2,715,449 A	8/1955	Lemmerman et al.	
2,759,093 A	8/1956	Ferar et al.	
2,951,001 A	8/1960	Rubenstein	
3,367,581 A	2/1968	Kizilos et al.	
3,385,963 A	5/1968	Washick	
3,420,023 A	1/1969	Werner	
D232,257 S *	7/1974	Paulson .....	D26/80
D239,780 S *	5/1976	Paulson .....	D26/102
3,967,823 A	7/1976	Yount	
D264,136 S	4/1982	Castiglioni	
4,437,287 A	3/1984	Halfaker	
4,555,114 A	11/1985	Dozier	
4,716,671 A	1/1988	Gross	
4,726,781 A	2/1988	Bernhart	
4,738,066 A *	4/1988	Reed .....	E04B 9/34 52/506.07
4,799,526 A	1/1989	Reeves	
5,226,724 A	7/1993	Kanarek	
D338,620 S	8/1993	Brozowski	
5,282,600 A	2/1994	Weiss	
D361,398 S *	8/1995	Neall, III .....	D26/109
5,532,073 A	7/1996	Hirata	
5,532,912 A	7/1996	Bendit	
5,658,066 A	8/1997	Hirsch	
5,662,412 A	9/1997	Glendmyer	
D387,459 S	12/1997	Cool	
5,702,180 A	12/1997	Huang	
D391,881 S	3/1998	Youseph	
D392,119 S *	3/1998	Montoya .....	D3/273
5,758,588 A	6/1998	Orfali	
D409,869 S	5/1999	Marusak	
5,947,786 A	9/1999	Glick	
D416,103 S	11/1999	Hashmi	
5,989,015 A	11/1999	Guerin	
6,025,549 A	2/2000	Harris	
D431,187 S	9/2000	Davis	
D432,868 S	10/2000	Tan	
D438,858 S	3/2001	del Castillo	
6,302,566 B1	10/2001	Cohon	

(73) Assignee: **3FORM, LLC**, Salt Lake City, UT (US)

(\* ) Notice: This patent is subject to a terminal disclaimer.

(\*\*) Term: **15 Years**

(21) Appl. No.: **29/660,967**

(22) Filed: **Aug. 23, 2018**

**Related U.S. Application Data**

(63) Continuation of application No. 15/902,731, filed on Feb. 22, 2018, now Pat. No. 10,889,987, which is a continuation-in-part of application No. 29/560,681, filed on Apr. 8, 2016, now Pat. No. Des. 819,860, which is a continuation-in-part of application No. 14/646,232, said application No. 29/560,681 is a continuation-in-part of application No. 14/767,890, filed on Aug. 13, 2015, now abandoned, said application No. 29/560,681 is a continuation-in-part of application No. 14/912,396, filed on Feb. 16, 2016, now Pat. No. 10,072,827.

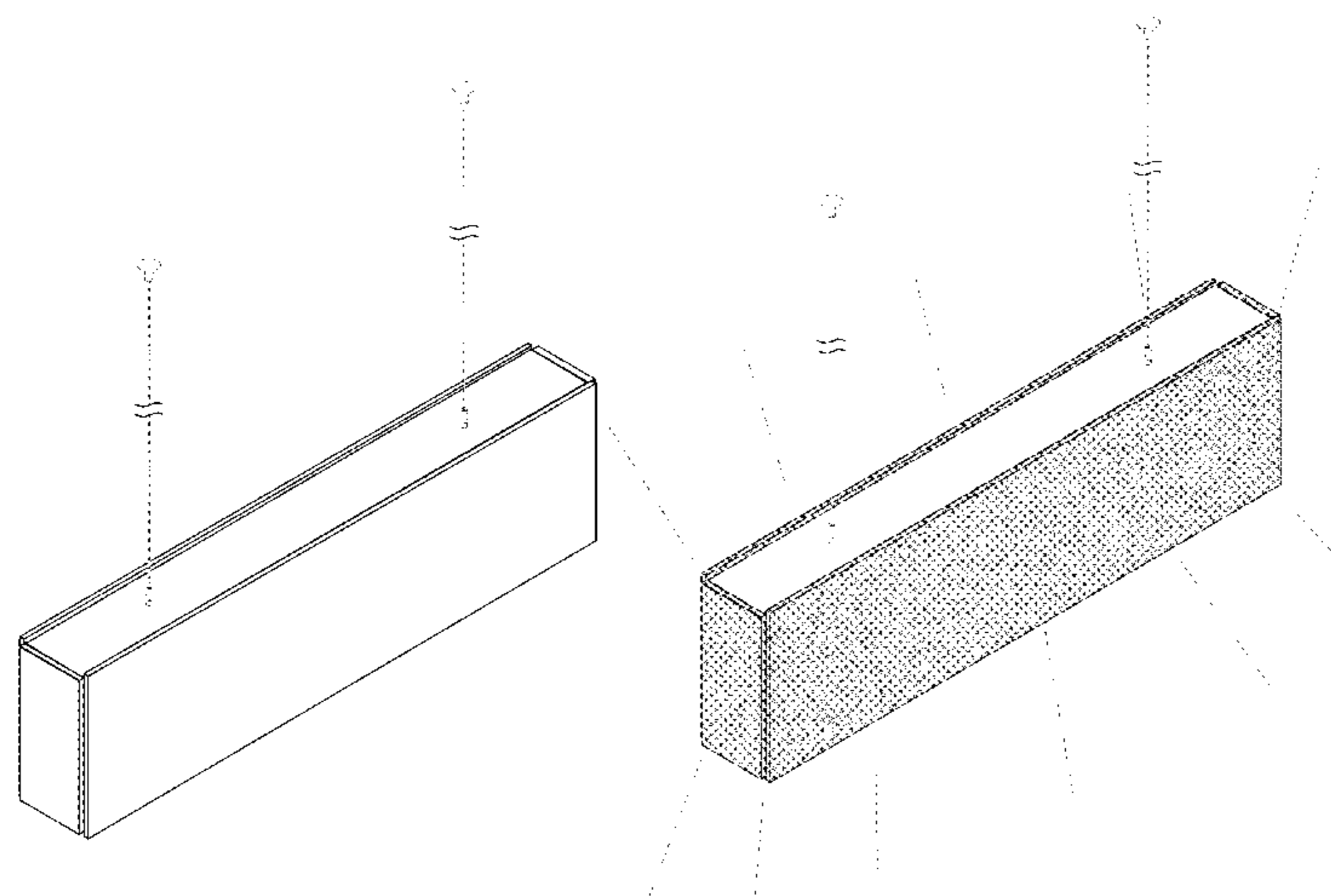
(51) **LOC (13) Cl.** ..... **25-01**

(52) **U.S. Cl.**  
USPC ..... **D25/138; D26/72**

(58) **Field of Classification Search**  
USPC ..... D9/432; D25/118, 136, 138, 144, 148, D25/152, 156-162, 164, 199; D26/72, D26/76, 88-90, 118

CPC ..... E04B 9/30; E04B 9/34; E04B 9/36; E04B 9/001; E04B 9/363; E04B 1/84; E04B 1/86; E04B 1/8404; F21S 8/06; F21S 8/061; F21S 8/063

See application file for complete search history.



# US D915,633 S

6,341,880 B1	1/2002	Hsu	D702,390 S	4/2014	Clark
6,367,581 B1	4/2002	Marler et al.	D702,391 S	4/2014	Clark
D468,474 S	1/2003	Poulton	8,714,775 B2	5/2014	Bracher
6,530,674 B2	3/2003	Grierson	D708,391 S	7/2014	Coury
D482,140 S	11/2003	Hughes et al.	D709,235 S	7/2014	Chu
D508,580 S	8/2005	Norris et al.	RE45,162 E	9/2014	Hierzer
6,964,507 B2	11/2005	Mohacsi	D716,486 S	10/2014	Martin
6,984,055 B2	1/2006	McCarthy	8,888,314 B2	11/2014	Gill
D514,364 S	2/2006	Hsu	8,953,926 B1	2/2015	Kelly
D523,328 S	6/2006	Ramos	8,967,823 B2	3/2015	D'Antonio
D523,771 S	6/2006	Kwan	D727,550 S	4/2015	Clark
D525,384 S	7/2006	Waycaster	D727,551 S	4/2015	Clark et al.
D525,738 S	7/2006	Waycaster	D727,554 S	4/2015	Clark
D536,468 S	2/2007	Crosby	D728,145 S	4/2015	Shiqiang
D541,970 S	5/2007	Blackman	9,004,713 B2	4/2015	Mandy et al.
D544,006 S	6/2007	Pinchot	D729,437 S	5/2015	Hillstrom
D553,788 S	10/2007	Holmes	9,028,114 B2	5/2015	Smith
D559,994 S	1/2008	Nagakubo	9,147,390 B2	8/2015	Swinkels et al.
D566,320 S	4/2008	Kim	D740,479 S	10/2015	Beno et al.
D566,882 S	4/2008	Min	D744,132 S	11/2015	Hollingworth
D570,026 S	5/2008	Waldmann	9,194,124 B2	11/2015	Johnson et al.
7,380,957 B2	6/2008	Lancy	D745,206 S	12/2015	Clark
7,431,489 B2	10/2008	Yeo et al.	D747,539 S *	1/2016	Santoro ..... D26/120
D584,446 S	1/2009	Sabernig	D751,237 S	3/2016	Ferrier
D584,848 S	1/2009	Menke	9,279,558 B2	3/2016	Gnasienco
7,504,159 B1	3/2009	Suare	D760,420 S	6/2016	Tomlinson
D591,444 S	4/2009	Beno et al.	D761,478 S	7/2016	Ng
D592,793 S	5/2009	Chandler	D761,990 S	7/2016	Ng
D595,887 S	7/2009	Blom	D761,991 S	7/2016	Clark
D595,888 S	7/2009	Sabernig	D761,992 S	7/2016	Ng
D595,891 S	7/2009	Sabernig	D764,095 S	8/2016	Clark
D596,452 S	7/2009	Komorski	9,404,646 B2	8/2016	Clark et al.
D599,037 S *	8/2009	Henriquez ..... D25/138	9,406,594 B2	8/2016	Blakely et al.
D599,945 S	9/2009	Pfund	D766,536 S	9/2016	Karatas
D600,394 S	9/2009	Ambruster	9,441,807 B2	9/2016	Smith
D603,083 S	10/2009	Trumble	D768,905 S	10/2016	Sonneman
D605,333 S	12/2009	Miranda	D768,906 S	10/2016	Sonneman
D613,897 S	4/2010	Thun	9,459,399 B2	10/2016	Krijn et al.
D620,189 S	7/2010	Hill et al.	D773,098 S	11/2016	Czech
D621,989 S *	8/2010	Proner ..... D26/76	D773,099 S	11/2016	Sonneman
7,766,536 B2	8/2010	Peifer	D774,239 S	12/2016	Pardo
7,789,544 B1	9/2010	Roach et al.	D774,679 S	12/2016	Huyghe
D626,278 S	10/2010	Sabernig	D774,682 S	12/2016	Chen
D628,218 S	11/2010	Tommassini	D776,855 S	1/2017	Rashid
D629,553 S	12/2010	Gielen	D780,364 S	2/2017	Czech et al.
D629,554 S	12/2010	Gielen	D780,976 S	3/2017	Czech et al.
D630,365 S	1/2011	Sabernig	D783,197 S	4/2017	Amdt
D632,004 S	2/2011	Waldmann	9,618,171 B2	4/2017	Sepkhanov et al.
D641,520 S	7/2011	Grajcar	D786,481 S	5/2017	Wiedemer
7,971,680 B2	7/2011	Morgan, III et al.	D786,483 S	5/2017	Sonneman
D650,509 S	12/2011	Wegger	9,644,820 B2	5/2017	Clark
D653,794 S	2/2012	Friedman	D790,103 S	6/2017	Czech et al.
D654,703 S	2/2012	Lemay	9,683,721 B2	6/2017	Clark et al.
D656,629 S	3/2012	Hauberg	D791,385 S	7/2017	Sonneman
D657,487 S	4/2012	Sabernig	D791,401 S	7/2017	Sonneman
D664,282 S	7/2012	Santoro et al.	D792,006 S	7/2017	Sonneman
D665,525 S	8/2012	Patterson	D792,632 S	7/2017	Amato
D666,354 S	8/2012	Bracher	D792,633 S	7/2017	Sonneman
D666,757 S	9/2012	Fisher et al.	D794,241 S	8/2017	Huyghe
D667,986 S	9/2012	Decq	D797,977 S	9/2017	Farzan
D668,371 S	10/2012	Alpasian	D797,982 S	9/2017	Sonneman
D669,759 S	10/2012	Catilleja	D799,097 S	10/2017	Sonneman
8,287,146 B2	10/2012	Hysky	D800,368 S	10/2017	Czech et al.
D671,676 S	11/2012	Komarov	9,792,891 B2	10/2017	Swinkels et al.
D676,587 S	2/2013	Fisher	D802,819 S	11/2017	Czech et al.
D676,996 S	2/2013	Gismondi	9,822,938 B2	11/2017	De Gier
D677,423 S	3/2013	Reddy	9,851,094 B2	12/2017	Gommans et al.
D684,294 S	6/2013	Goodson	D806,927 S	1/2018	Rashid
D684,307 S	6/2013	Teller	D806,929 S	1/2018	Clark
D686,363 S	7/2013	Smith	D810,993 S	2/2018	Genovese
D687,589 S	8/2013	Wick	9,920,525 B1 *	3/2018	Underkofler ..... E04B 9/366
8,517,845 B2	8/2013	Shin	D817,537 S	5/2018	Clark
D689,647 S	9/2013	Brott et al.	9,964,692 B2	5/2018	SanFacon et al.
D692,391 S	10/2013	Kim	D819,860 S	6/2018	Clark
D693,045 S	11/2013	Kirshhoffer et al.	9,995,466 B2	6/2018	SanFacon et al.
8,613,526 B1	12/2013	Li et al.	10,024,522 B2	7/2018	Clark et al.
D697,662 S	1/2014	Patterson	10,030,850 B2	7/2018	Vissenberg et al.
D698,983 S	2/2014	Rampolla	D825,811 S	8/2018	Clark
D700,732 S	3/2014	Clark	D826,450 S	8/2018	Clark

D827,908 S	9/2018	Silver et al.	
D828,612 S	9/2018	Silver et al.	
D835,333 S	12/2018	Silver	
D836,238 S	12/2018	Ericson, Jr. et al.	
10,151,454 B2	12/2018	Farrell et al.	
D847,395 S	4/2019	Tremaine et al.	
10,274,664 B2	4/2019	Wang et al.	
D848,047 S	5/2019	Santoro et al.	
10,359,163 B1 *	7/2019	Hettwer .....	E04B 9/32
D858,853 S	9/2019	Anastasiades	
D860,507 S	9/2019	Greenberg et al.	
D861,960 S *	10/2019	Ng .....	D26/90
D880,043 S *	3/2020	Guerra .....	D26/76
10,598,355 B2	3/2020	Ross et al.	
D880,754 S	4/2020	Ross et al.	
10,672,376 B1 *	6/2020	Pickens .....	F21V 23/023
D889,732 S	7/2020	Silver	
10,718,476 B2	7/2020	Santos et al.	
10,725,231 B2	7/2020	Ross et al.	
D896,429 S	9/2020	Velez	
10,782,005 B2	9/2020	Guerra et al.	
D898,979 S	10/2020	Silver	
D899,668 S	10/2020	Arni et al.	
2001/0046621 A1	11/2001	Colli	
2002/0071281 A1	6/2002	Dickson	
2004/0027830 A1	2/2004	Chen	
2004/0226230 A1	11/2004	Ritzer	
2006/0146531 A1	6/2006	Reo et al.	
2007/0058377 A1	3/2007	Zampini, II et al.	
2007/0247842 A1	10/2007	Zampini et al.	
2008/0266842 A1	10/2008	Skidmore et al.	
2008/0314944 A1	12/2008	Tsai	
2009/0126139 A1	5/2009	Batti et al.	
2010/0149791 A1	7/2010	McCane et al.	
2011/0170294 A1	7/2011	Mier-Langner	
2012/0081919 A1	4/2012	Parker	
2013/0016847 A1	1/2013	Steiner	
2013/0094225 A1	4/2013	Leichner	
2013/0148357 A1	6/2013	Johnson et al.	
2014/0009927 A1	1/2014	Gnasienco	
2014/0022759 A1	1/2014	Li	
2014/0024249 A1	1/2014	Adams et al.	
2014/0063803 A1	3/2014	Yaphe	
2014/0133150 A1	5/2014	Pardikes et al.	
2014/0153257 A1	6/2014	Smith	
2014/0198494 A1	7/2014	Lextar	
2014/0334178 A1	11/2014	Zharov	
2015/0226384 A1 *	8/2015	Park .....	F21V 21/34 362/223
2015/0300605 A1	10/2015	Clark	
2015/0300610 A1	10/2015	DeCarr et al.	
2016/0061429 A1	3/2016	Waalkes	
2016/0245488 A1	8/2016	Clark	
2016/0281940 A1	9/2016	Kim	
2017/0138561 A1	5/2017	Van Strander	
2017/0159928 A1 *	6/2017	Gommans .....	E04B 9/32
2017/0268752 A1 *	9/2017	Horvath .....	F21V 23/005
2017/0370098 A1	12/2017	Honji et al.	
2018/0127975 A1 *	5/2018	Gillette .....	E04B 9/045
2018/0180233 A1	6/2018	Mellor	
2018/0226003 A1	8/2018	Szekely	
2018/0245334 A1	8/2018	Udagawa et al.	
2018/0266668 A1	9/2018	Myers et al.	
2018/0267228 A1	9/2018	Epstein et al.	
2018/0334804 A1 *	11/2018	Patterson .....	E04F 13/0801
2018/0336875 A1	11/2018	Patterson et al.	
2019/0017260 A1	1/2019	Bou Harb et al.	
2019/0035376 A1	1/2019	Pilaar	
2019/0041570 A1	2/2019	Yeo et al.	
2019/0088241 A1	3/2019	Czech et al.	
2019/0096954 A1	3/2019	Cromptvoets et al.	
2019/0106883 A1	4/2019	Moore et al.	
2019/0162369 A1	5/2019	Sonneman et al.	
2019/0186132 A1	6/2019	Knoblauch et al.	
2019/0234595 A1	8/2019	Beland et al.	
2019/0309937 A1	10/2019	Chen et al.	
2020/0053967 A1 *	2/2020	Murphy .....	F21S 8/061

FOREIGN PATENT DOCUMENTS

DE	2349401	9/1973
DE	102008026504	3/2009
DE	202009013052	3/2011
DE	102012110575	5/2014
EP	2375151	4/2011
EP	2813630	5/2013
EP	2864559	4/2015
EP	2990559	8/2015
GB	2556679	6/2018
JP	2003217332	7/2003
JP	2011159472	8/2011
KR	2020100007653	7/2010
KR	2020120007760	11/2012
KR	101454180	10/2014
WO	2013006790	1/2013
WO	2013058961	4/2013
WO	2013/190447 A2	12/2013
WO	2014/073907 A1	5/2014
WO	2014081621	5/2014
WO	2014/184156 A1	11/2014
WO	2015073907	5/2015
WO	2015184156	12/2015

OTHER PUBLICATIONS

Highly Effective Acoustic Baffles (available online) Retrieved from the internet Aug. 3, 2020 from URL: [www.soundsorba.com/acoustic-products/sound-absorption/bafflesorba/](http://www.soundsorba.com/acoustic-products/sound-absorption/bafflesorba/).\*

Non-Final Office Action for U.S. Appl. No. 29/647,681 dated Nov. 4, 2019.

Search Report for application No. GB1715859.3 dated Oct. 2, 2018.

Non-Final Office Action for U.S. Appl. No. 16/577,636 dated Feb. 21, 2020.

Notice of Allowance for U.S. Appl. No. 15/902,731 dated Feb. 26, 2020.

Office Action in U.S. Appl. No. 15/076,852 dated Jun. 2, 2017.

Office Action in U.S. Appl. No. 29/560,673 dated May 10, 2017.

Light art (available online Oct. 21, 2013) Retrieved from the internet Mar. 16, 2017, retrieved from the internet URL: [www.youtube.com](http://www.youtube.com) (search "Lightart.com").

Tin eye reference (available online Oct. 8, 2014) Retrieved from the internet Mar. 23, 2017, retrieved from the internet URL: <https://tineye.com/search/cb9bd08581564e1b2247fa8b78f73b92f57cc422/> Reference internet site URL: <https://www.architonic.com/en/product/henge-light-ring-medium/1149533>.

Ring shade 32 LED Pendant (available online Mar. 28, 2015) Retrieved from the internet Apr. 8, 2017, retrieved from the internet URL: <https://web-beta.archive.org/web/20150328234600/http://www.sonnemanawayofflight.com/ringshade32ledpendant-p-922.html>.

Light In The Box (available online Dec. 30, 2014) Retrieved from the internet Mar. 16, 2017, retrieved from the internet URL: [https://www.amazon.com/LightInTheBox-RingHome-Chandeliers-Lighting-110-120V/dp/B00RL1N79W/ref=pd\\_bxgy\\_60\\_img\\_3?\\_encoding=UTF8&pd\\_rd\\_i=B00RL1N79W&pd\\_rd\\_r=0K15VB464BCF6J7RV59C&pd\\_rd\\_w=3rhz3&pd\\_rd\\_wg=r7IJv&pvc=1&refRID=0K15VB4](https://www.amazon.com/LightInTheBox-RingHome-Chandeliers-Lighting-110-120V/dp/B00RL1N79W/ref=pd_bxgy_60_img_3?_encoding=UTF8&pd_rd_i=B00RL1N79W&pd_rd_r=0K15VB464BCF6J7RV59C&pd_rd_w=3rhz3&pd_rd_wg=r7IJv&pvc=1&refRID=0K15VB4).

International Search Report & Written Opinion for application No. PCT/US14/65816 dated Feb. 19, 2015.

International Search Report & Written Opinion for application No. PCT/US2015/033014 dated Sep. 8, 2015.

International Search Report & Written Opinion for application No. PCT/US2013/070236 dated Mar. 11, 2014.

Office Action in U.S. Appl. No. 14/767,890 dated May 12, 2017.

Office Action in U.S. Appl. No. 14/646,232 dated Dec. 15, 2016.

Ex Parte Quayle Action for U.S. Appl. No. 29/481,765 dated May 9, 2016.

Ex Parte Quayle Action for U.S. Appl. No. 29/545,539 dated May 23, 2016.

Office Action for U.S. Appl. No. 29/481,765 dated Oct. 16, 2015.

Requirement for Restriction for U.S. Appl. No. 29/530,073 dated May 30, 2017.

- Office Action for U.S. Appl. No. 14/646,232 dated May 2, 2016.
- Office Action for U.S. Appl. No. 29/560,681 dated Jun. 15, 2017.
- Modern Square LED Chandelier Lighting (available online Sep. 22, 2015) Retrieved from the internet Jun. 2, 2017, retrieved from the internet URL: [https://www.amazon.com/VONN-VMC31620AL-Chandelier-Lighting-Adjustable/dp/B0150G45GE/ref=sr\\_1\\_2?ie=UTF8&qid=1498172914&sr=8-2&keywords=Modern+Square+LED+Chandelier+Lighting](https://www.amazon.com/VONN-VMC31620AL-Chandelier-Lighting-Adjustable/dp/B0150G45GE/ref=sr_1_2?ie=UTF8&qid=1498172914&sr=8-2&keywords=Modern+Square+LED+Chandelier+Lighting).
- Modern Two-Tier LED Chandelier (available online Sep. 22, 2015) Retrieved from the internet Jun. 2, 2017, retrieved from the Internet URL: [https://www.amazon.com/VONN-VMC31710SW-Two-Tier-Chandelier-Adjustable/dp/B0150G4J8S/ref=pd\\_sbs\\_60?\\_encoding=UTF8&pd\\_rd\\_i=B0150G4J8S&pd\\_rd\\_r=9GZ57EM9VFSJZMQW1ERC&pd\\_rd\\_w=XsCRS&pd\\_rd\\_wg=VbWDy&pvc=1&refRID=9GS7CM9VFSJZ](https://www.amazon.com/VONN-VMC31710SW-Two-Tier-Chandelier-Adjustable/dp/B0150G4J8S/ref=pd_sbs_60?_encoding=UTF8&pd_rd_i=B0150G4J8S&pd_rd_r=9GZ57EM9VFSJZMQW1ERC&pd_rd_w=XsCRS&pd_rd_wg=VbWDy&pvc=1&refRID=9GS7CM9VFSJZ).
- Astro D-Light wall Light (available online) Retrieved from the internet Jun. 2, 2017, retrieved from the internet URL: <https://www.lovelights.co.uk/led-lighting-c17/astro-d-light-led-wall-light-p22295>.
- Notice of Allowance for U.S. Appl. No. 15/076,852 dated Oct. 11, 2017.
- Non-Final Office Action for U.S. Appl. No. 29/530,073 dated Sep. 1, 2017.
- Notice of Allowance for U.S. Appl. No. 29/560,673 dated Nov. 13, 2017.
- Non-Final Office Action for U.S. Appl. No. 14/912,396 dated Dec. 29, 2017.
- Final Office Action for U.S. Appl. No. 14/767,890 dated Dec. 29, 2017.
- Non-Final Office Action for U.S. Appl. No. 29/560,686 dated Jan. 9, 2018.
- The807, (Feb. 5, 2014), [online], [site visited Jan. 4, 2018]. Available from internet <URL: Retrieved from <https://www.etsy.com/uk/listing/176582577/triangle-shadow-box-set-of-3?ref=related-2>>.
- Non-Final Office Action for U.S. Appl. No. 29/560,688 dated Jan. 9, 2018.
- EONeyeofnature. (Jan. 5, 2015), [online], [site visited Jan. 4, 2018]. Available from internet, <URL: Retrieved from [https://www.etsy.com/uk/listing/217343723/set-of-four-hexagon-honeycomb-shelves-in?show\\_sold\\_out\\_detail=1](https://www.etsy.com/uk/listing/217343723/set-of-four-hexagon-honeycomb-shelves-in?show_sold_out_detail=1)>.
- Search Report for application No. GB1715859.3 dated Mar. 8, 2018.
- Non-Final Office Action for U.S. Appl. No. 14/767,890 dated Jun. 4, 2018.
- Search Report for application No. 18162643.3-1015, dated Jul. 13, 2018.
- “Mounted Lighting LED Linear Trunking Light (available online) Retrieved from the internet Sep. 27, 2018 from URL: <https://hkenrich.en.made-in-china.com/productimage/JNrxlIEKuYha2flj00gaYGPSmBbqoC/China-3-UYears-Warranty-Ceiling-Mounted-Lighting-LED-Linear-Trunking-L>”.
- “Mumu LED Linear Suspension Pendant Light (available online) Retrieved from the internet Sep. 27, 2018 from URL: <https://www.ylighting.com/mumu-led-linear-suspension-pendant-light-by-seed-design-SEDP149479.html#cgid=%DAYLLIG%0A&&VtileIndex=14>”.
- Non-Final Office Action for U.S. Appl. No. 29/647,681 dated Jun. 4, 2018.
- Search Report for application No. GB1804368.7 dated Sep. 17, 2018.
- Final Office Action for U.S. Appl. No. 15/719,070 dated Feb. 3, 2020.
- Office Action dated Aug. 23, 2019 from U.S. Appl. No. 15/719,070, filed Sep. 28, 2017.
- Non-Final Office Action for U.S. Appl. No. 15/902,731 dated Jul. 29, 2019.
- Acoshape+ Modell Barcode Acoustic Submitted to U.S. Appl. No. 15/973,054.
- Acoshape+ Modell Barcode Down Submitted to U.S. Appl. No. 15/973,054.
- Acoshape+ Modell Barcode Down/Up Submitted to U.S. Appl. No. 15/973,054.
- Acoshape+ Modell Morse 3 Submitted to U.S. Appl. No. 15/973,054.
- Acoshape+ Modell Morse 4 Submitted to U.S. Appl. No. 15/973,054.
- Ringo Star Acoustic-P6/G6 Submitted to U.S. Appl. No. 15/973,054.
- Spectral Blade Light and Acoustic Baffles Submitted to U.S. Appl. No. 15/973,054.
- Architonic light ring Tin Eye search result Oct 28th 2014 (available online Oct. 28, 2014) Retrieved from the internet Aug. 11, 2020 from URL: <https://tineye.com/search/8ef4cda898fab73fd1d06a6d7262af01589cc18b?sort=score&order=desc&page=1>.
- Artemide Edge 30 (registered) Pendant Light (available Apr. 24, 2015) Retrieved Oct. 29, 2019 from URL: <https://web.archive.org/web/20150424054229/https://www.stardust.com/EDGE30.html>.
- Corrected Notice of Allowability from U.S. Appl. No. 29/560,686 dated Jul. 11, 2018.
- Cube LED Lamp (available Sep. 19, 2011) Retrieved Oct. 29, 2019 from URL: <https://www.amazon.com/SMART-GREEN-814495012024-Cube-Lamp/dp/B00500PG10>.
- Exam Report from GB Application No. 1508387 dated Aug. 15, 2019.
- Final Office Action for U.S. Appl. No. 29/647,681 dated Apr. 2, 2019.
- Final Office Action from U.S. Appl. No. 14/767,890 dated May 17, 2019.
- Foyer Pendant (available online Mar. 2, 2015) Retrieved from the internet Aug. 17, 2020 from URL: <https://www.fergusonshowrooms.com/product/et2-EE22405-bronze-870257?tb=>.
- IPRP from PCT App. No. PCT/US2015/033014 dated Nov. 29, 2016.
- IPRP from PCT Application No. PCT/US2013/070236 dated May 26, 2015.
- IPRP from PCT Application No. PCT/US2014/065816 dated May 17, 2016.
- Light Ring Medium designer furniture Architonic (available online Oct. 28, 2014) Retrieved from the internet Aug. 11, 2020 from URL: <https://www.architonic.com/en>.
- Matric Ready Square 2in Suspension G3/R4 (available online) Retrieved from the internet Aug. 17, 2020 from URL: <https://www.lightformshop.com/Brands-lights/matric-ready-square-2in-suspension-g3-r4>.
- Modell Slab 150 Submitted to U.S. Appl. No. 15/973,054.
- Morfi Small (available online) Retrieved from the internet Aug. 14, 2020 from URL: <https://www.architonic.com/en/product/petridis-s-a-morfi-small/20103072>.
- Notice of Allowance for U.S. Appl. No. 14/912,396 dated May 2, 2018.
- Notice of Allowance from U.S. Appl. No. 14/646,232 dated Mar. 24, 2017.
- Notice of Allowance from U.S. Appl. No. 15/076,852 dated Jan. 16, 2018.
- Notice of Allowance from U.S. Appl. No. 29/481,765 dated Jun. 7, 2016.
- Notice of Allowance from U.S. Appl. No. 29/545,539 dated Jul. 1, 2016.
- Notice of Allowance from U.S. Appl. No. 29/560,281 dated Mar. 26, 2018.
- Notice of Allowance from U.S. Appl. No. 29/560,686 dated May 22, 2018.
- Notice of Allowance from U.S. Appl. No. 29/560,688 dated May 22, 2018.
- Notice of Allowance received for U.S. Appl. No. 15/902,731, dated Aug. 21, 2020, 5 pages.
- Notice of Allowance received for U.S. Appl. No. 15/902,731, dated Jun. 9, 2020, 7 pages.
- Notice of Allowance received for U.S. Appl. No. 16/577,636, dated Aug. 21, 2020, 5 pages.
- Notice of Allowance received for U.S. Appl. No. 16/577,636, dated Jul. 21, 2020, 5 pages.
- Office Action in U.S. Appl. No. 29/560,688 dated Jun. 2, 2017.
- Restriction Requirement for U.S. Appl. No. 16/577,636 dated Nov. 5, 2019.
- Restriction Requirement from U.S. Appl. No. 15/719,070 dated May 6, 2019.
- Restriction Requirement from U.S. Appl. No. 29/481,765 dated Jun. 18, 2015.

Shop.ferguson Foyer Pendant tineye reference (available online Mar. 2, 2015) Retrieved from the internet Aug. 17, 2020 from URL: [https://tineye.com/search/9ae3a7322908e09d1d83fcc3df9d473b18a90f1c?sort=crawl\\_date&order=asc&page=1](https://tineye.com/search/9ae3a7322908e09d1d83fcc3df9d473b18a90f1c?sort=crawl_date&order=asc&page=1) 1.

Supplemental Notice of Allowability for U.S. Appl. No. 14/912,396 dated Jul. 9, 2018.

Triangle Pendantlampjavailalbe online Dec. 29, 2017) Retrieved from the internet Aug. 16, 2020 from URL: [https://www.archiproducts.com/en/products/hollis-morris/led-indirect-light-pendant-lamp-triangle-pendant-lamp\\_265978](https://www.archiproducts.com/en/products/hollis-morris/led-indirect-light-pendant-lamp-triangle-pendant-lamp_265978).

White Hanging Lamp (available May 15, 2014) Retrieved Oct. 29, 2019 from URL: <https://www.tineye.com/search/35381e6751046292c6cf07131bcc7d37a42e0fa7?page=1>.

Notice of Allowance received for U.S. Appl. No. 16/577,636, dated Oct. 9, 2020, 2 pages.

ABL3-LED Modern Lighting (on-line), dated Sep. 30, 2020. Retrieved from Internet Dec. 9, 2020, URL: <https://web.archive.org/web/20200930005620/https://www.mobem.com/products/ab13-led> (2 pages) (Year: 2020).

Acoustic Baffle and Lighting System—Arktura SoundBar (on-line), dated Aug. 08, 2020. Retrieved from Internet Dec. 9, 2020, URL: <https://web.archive.org/web/20200808002745/https://arktura.com/product/soundbar1> (1 pages) (Year: 2020).

Blade Silent Light—Architecture Today (on-line), no date available. Retrieved from Internet Dec. 9, 2020, URL: <https://architecturetoday.co.uk/blade-silent-light/> (5 pages).

LSI—STFU Series (on-line), dated Jun. 20, 2019. Retrieved from Internet Dec. 7, 2020, URL: <https://web.archive.org/web/20190620155204/https://coronetled.com/Is1-sffu/> (2 pages) (Year: 2019).

Product Monday—Seem 1 Acoustic by Focal Point-LightNOW (on-line), dated May 20, 2019. Retrieved from Internet Dec. 9, 2020, URL: <https://www.lightnowblog.com/2019/05/product-monday-seem-1-acoustic-by-focal-point/> (2 pages) (Year: 2019).

\* cited by examiner

*Primary Examiner* — Kevin K Rudzinski

*Assistant Examiner* — Richard Kearney

(74) *Attorney, Agent, or Firm* — Workman Nydegger

(57)

**CLAIM**

The ornamental design for a baffle, as shown and described.

**DESCRIPTION**

FIG. 1 is a top front left perspective view of a baffle including my design;

FIG. 2 is a front elevation view thereof;

FIG. 3 is a rear elevation view thereof;

FIG. 4 is a left elevation view thereof;

FIG. 5 is a right elevation view thereof;

FIG. 6 is a top plan view thereof;

FIG. 7 is a bottom plan view thereof;

FIG. 8 is a top front left perspective view of an alternative embodiment of a baffle in which light is emitted from a top surface and bottom surface thereof including my design;

FIG. 9 is a front elevation view thereof;

FIG. 10 is a rear elevation view thereof;

FIG. 11 is a left elevation view thereof;

FIG. 12 is a right elevation view thereof;

FIG. 13 is a top plan view thereof;

FIG. 14 is a bottom plan view thereof;

FIG. 15 is a top front left perspective view of an alternative embodiment of a baffle in which portions are wrapped in felted polyethylene terephthalate (PET) including my design;

FIG. 16 is a front elevation view thereof;

FIG. 17 is a rear elevation view thereof;

FIG. 18 is a left elevation view thereof;

FIG. 19 is a right elevation view thereof;

FIG. 20 is a top plan view thereof;

FIG. 21 is a bottom plan view thereof;

FIG. 22 is a top front left perspective view of an alternative embodiment of a baffle in which portions are wrapped in felted polyethylene terephthalate (PET) and in which light is emitted from a top surface and bottom surface thereof including my design;

FIG. 23 is a front elevation view thereof;

FIG. 24 is a rear elevation view thereof;

FIG. 25 is a left elevation view thereof;

FIG. 26 is a right elevation view thereof;

FIG. 27 is a top plan view thereof; and,

FIG. 28 is a bottom plan view thereof.

The broken lines are included for the purpose of showing environmental portions of the baffle and form no part of the claimed design.

**1 Claim, 12 Drawing Sheets**

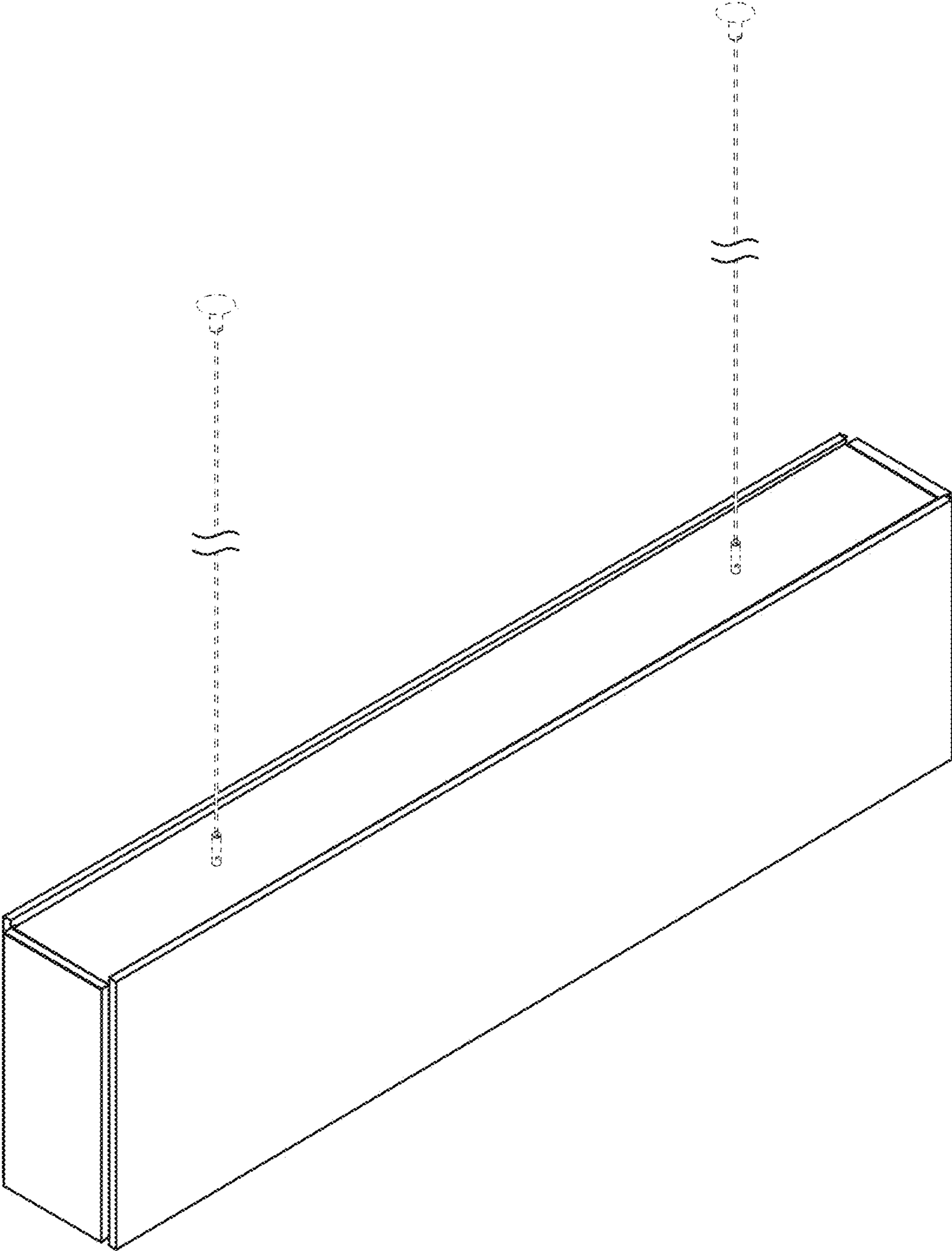


FIG. 1

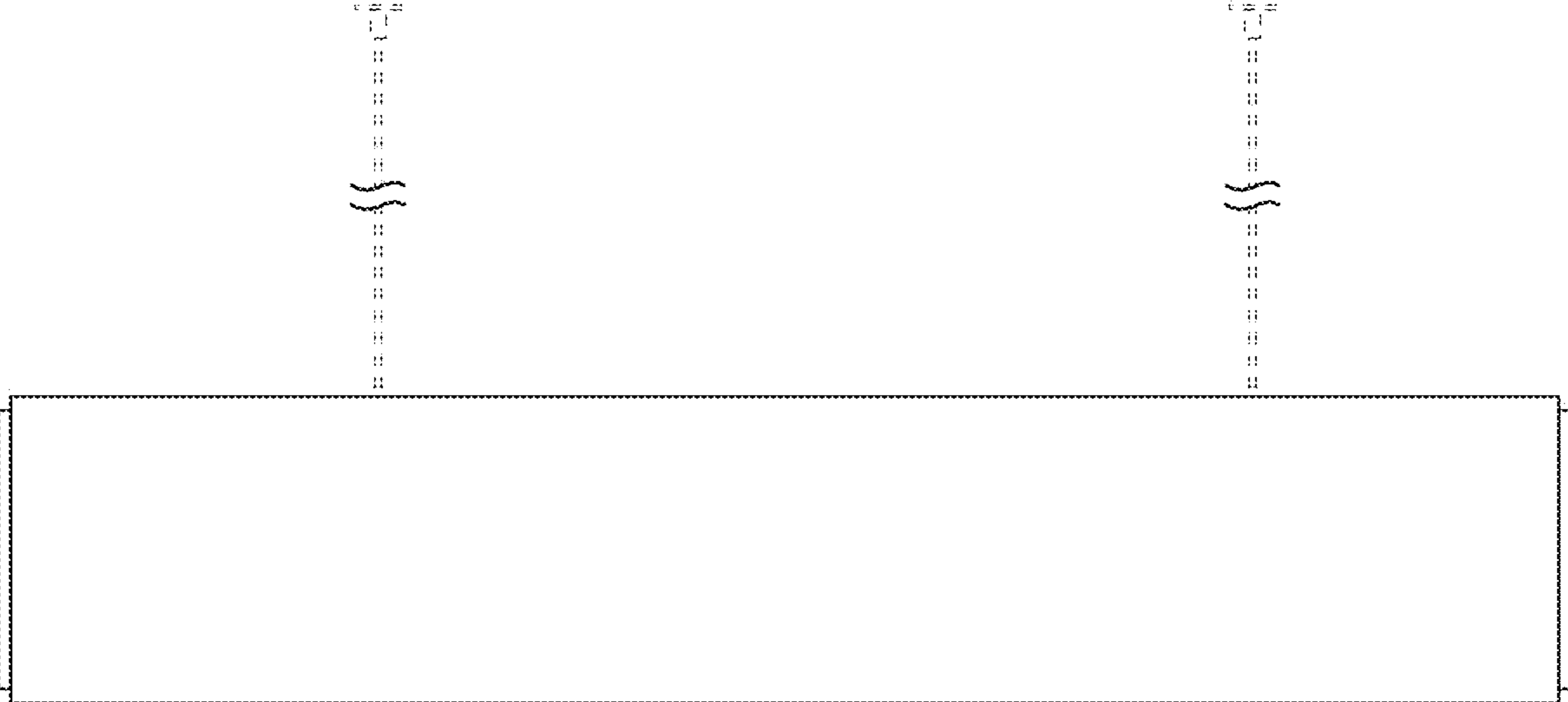


FIG. 2

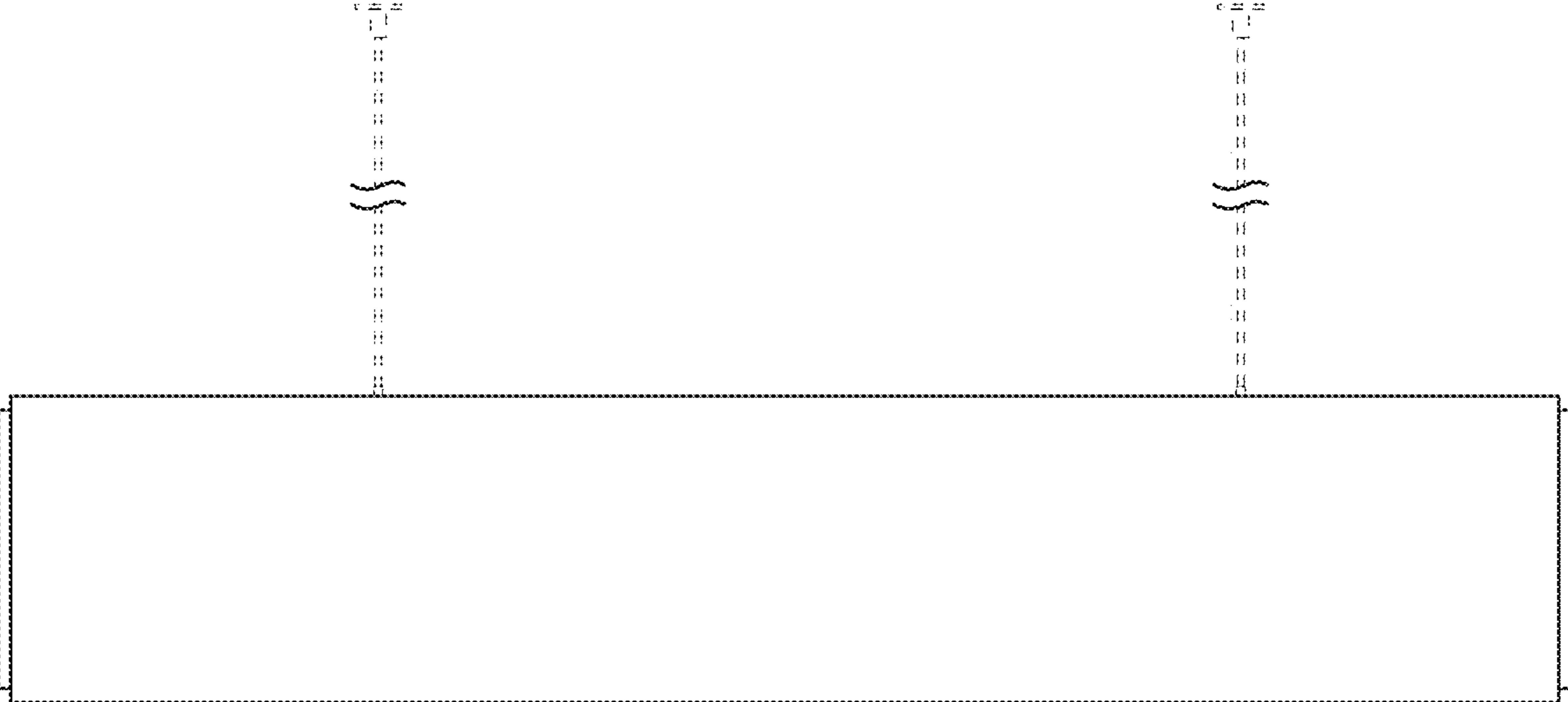
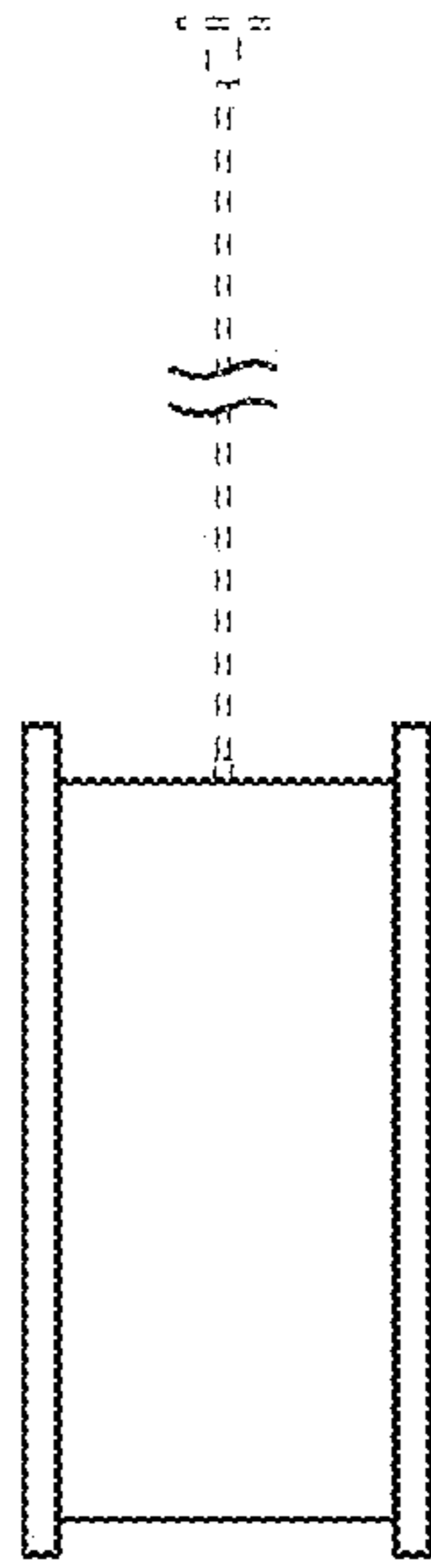
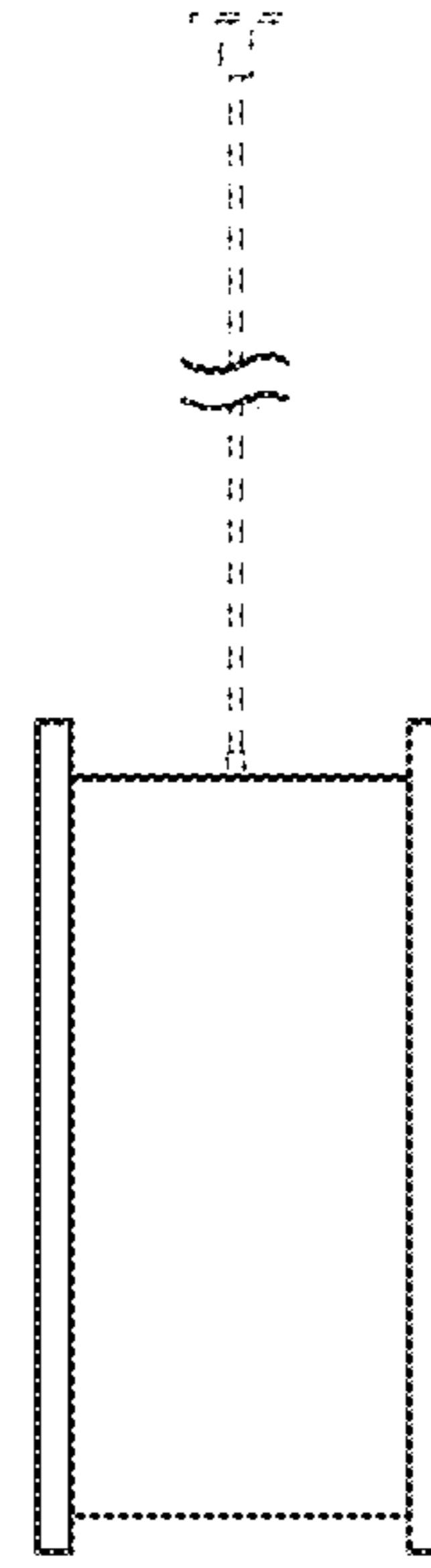


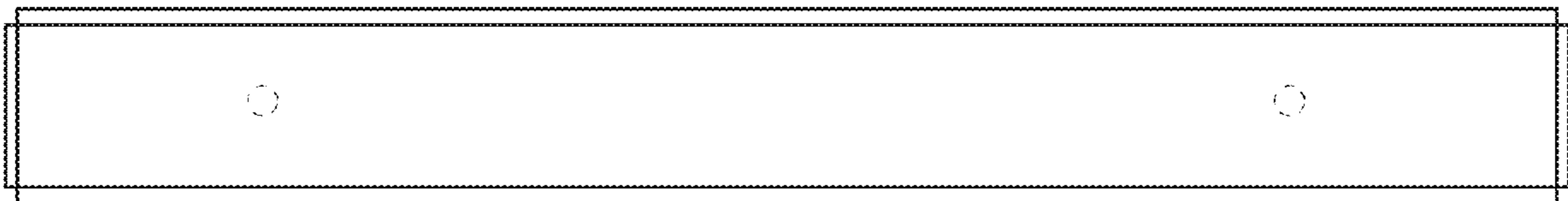
FIG. 3



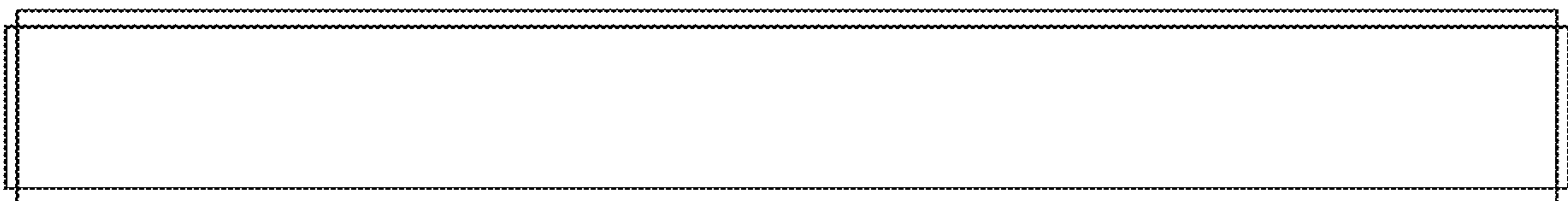
**FIG. 4**



**FIG. 5**

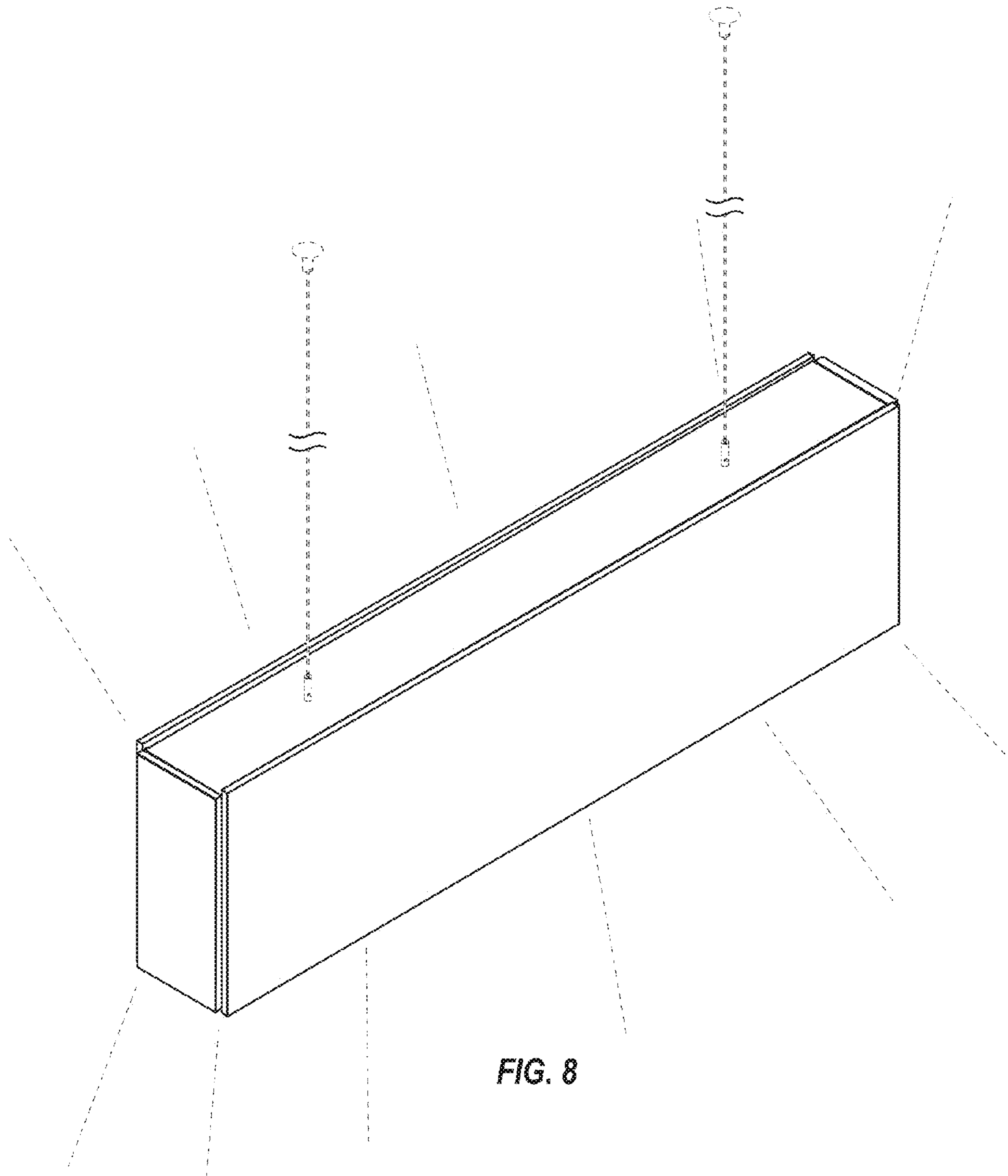


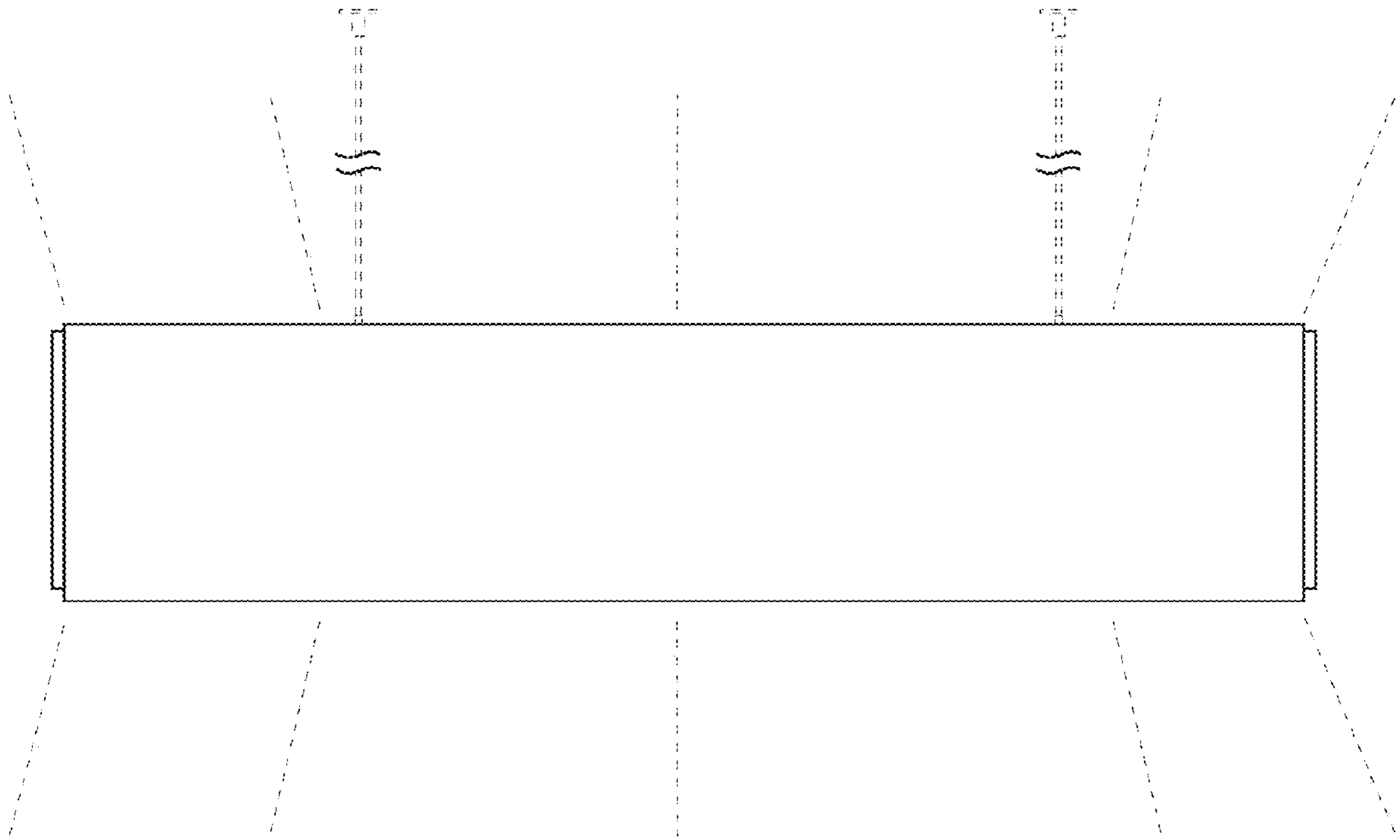
**FIG. 6**



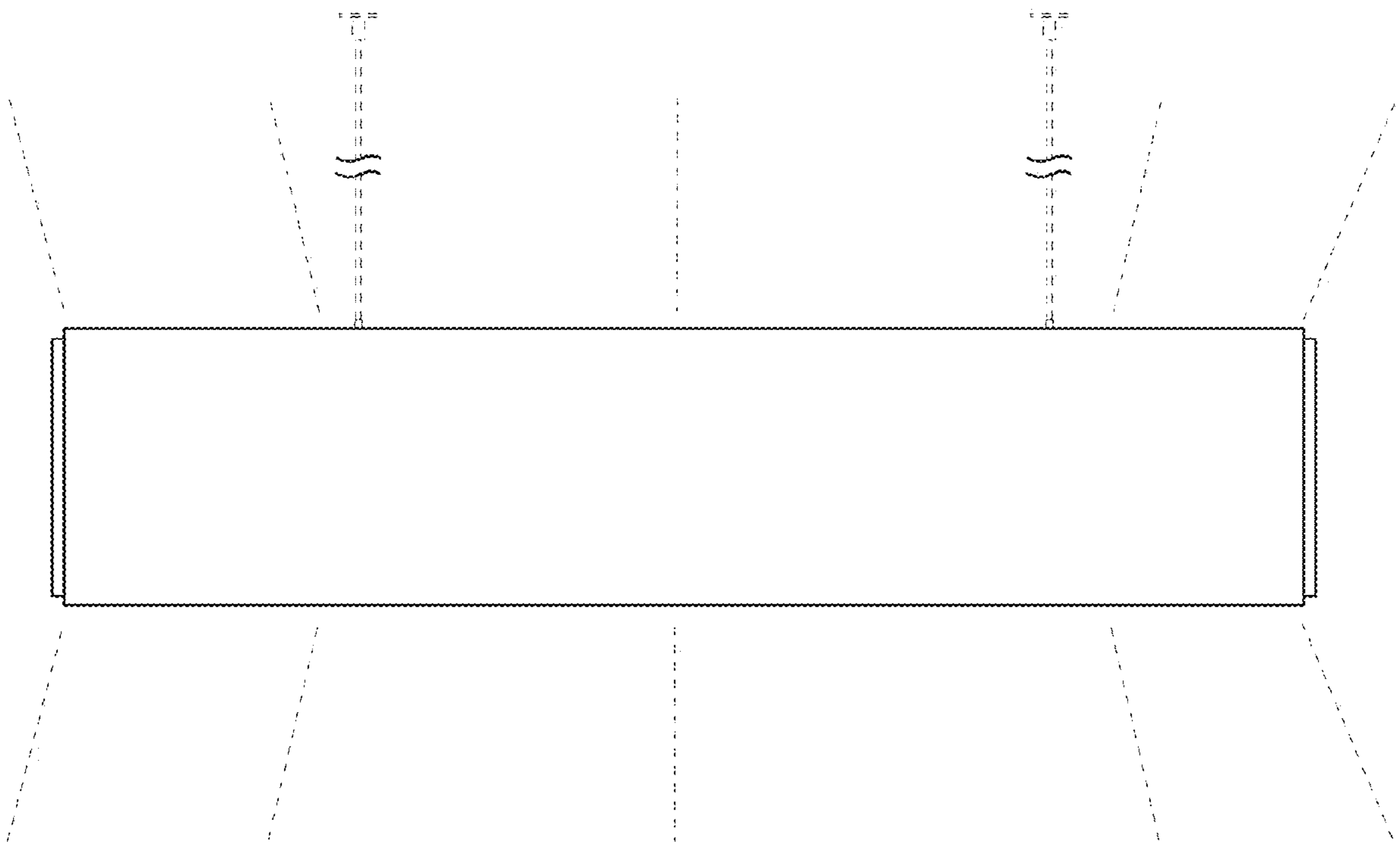
**FIG. 7**



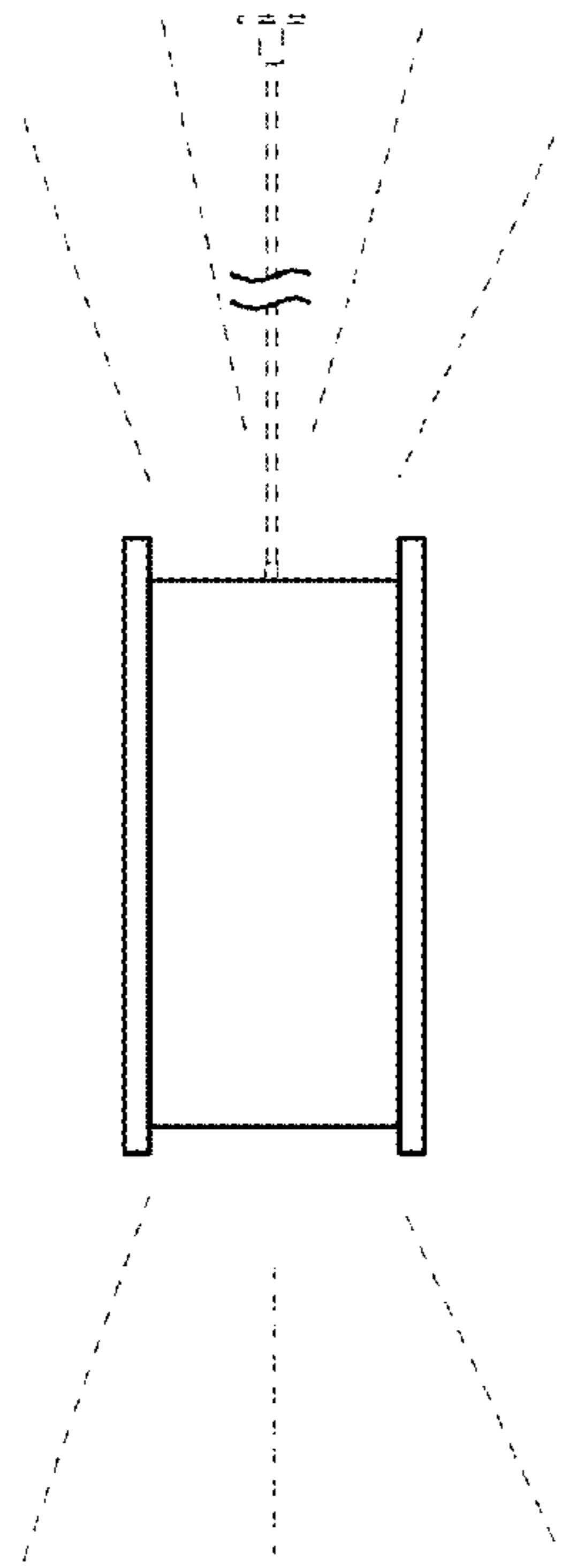




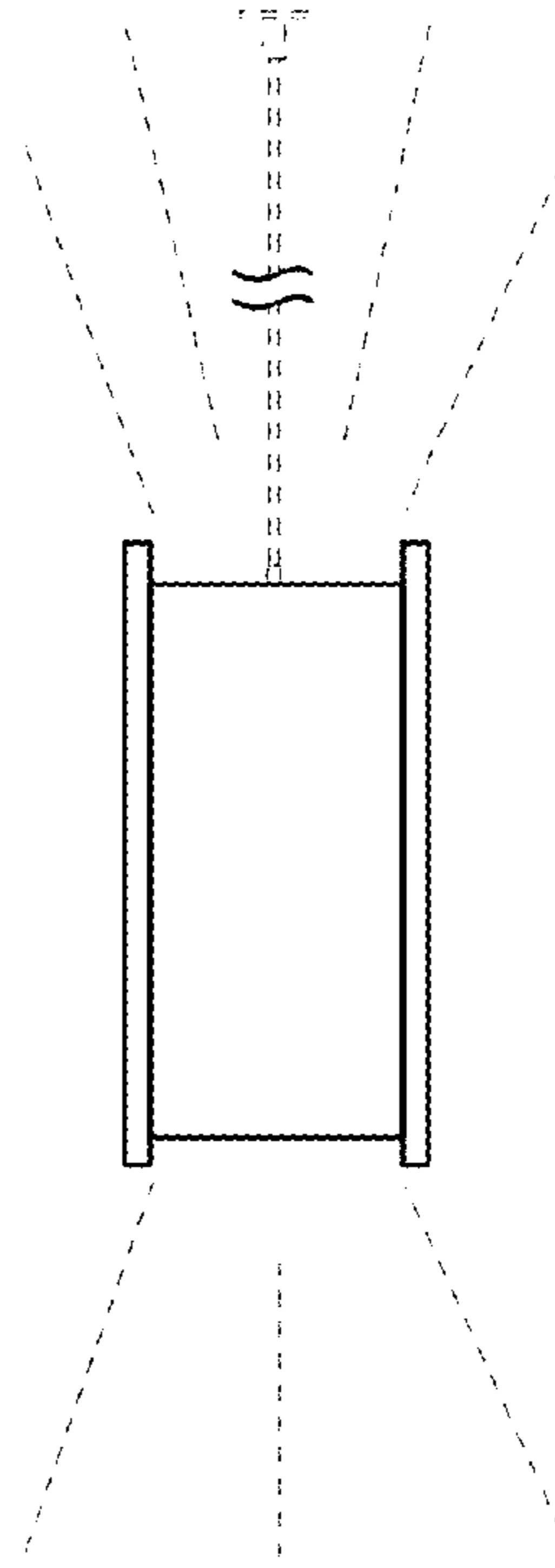
**FIG. 9**



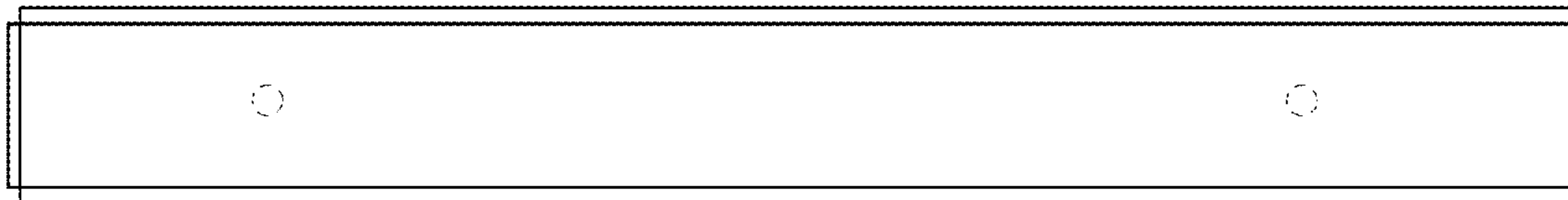
**FIG. 10**



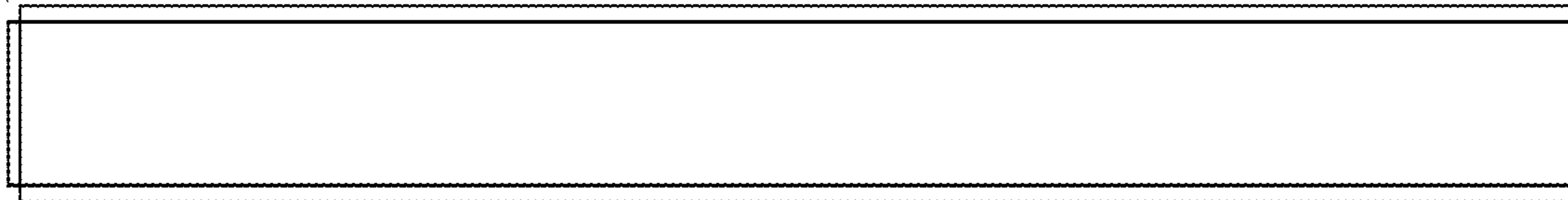
**FIG. 11**



**FIG. 12**



**FIG. 13**



**FIG. 14**

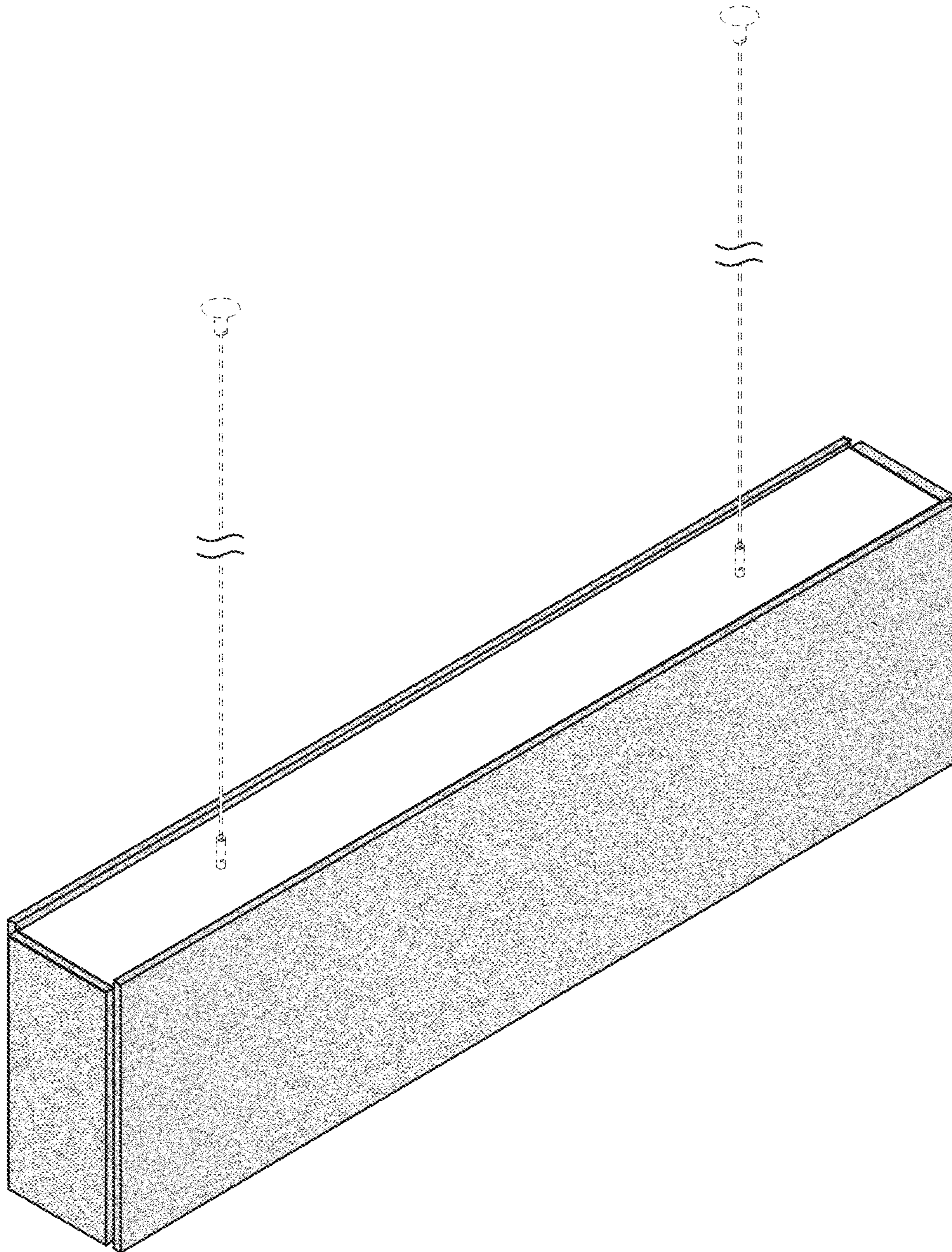
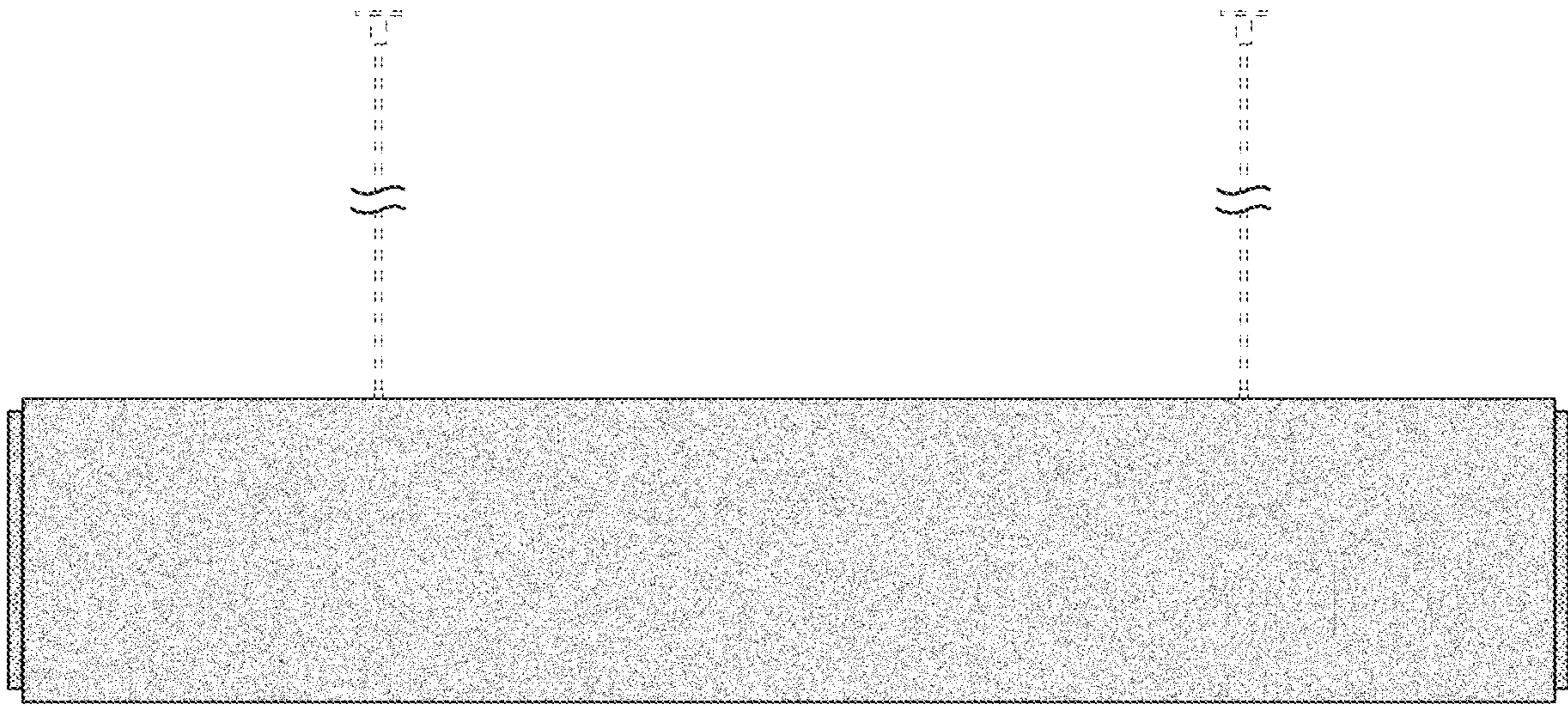
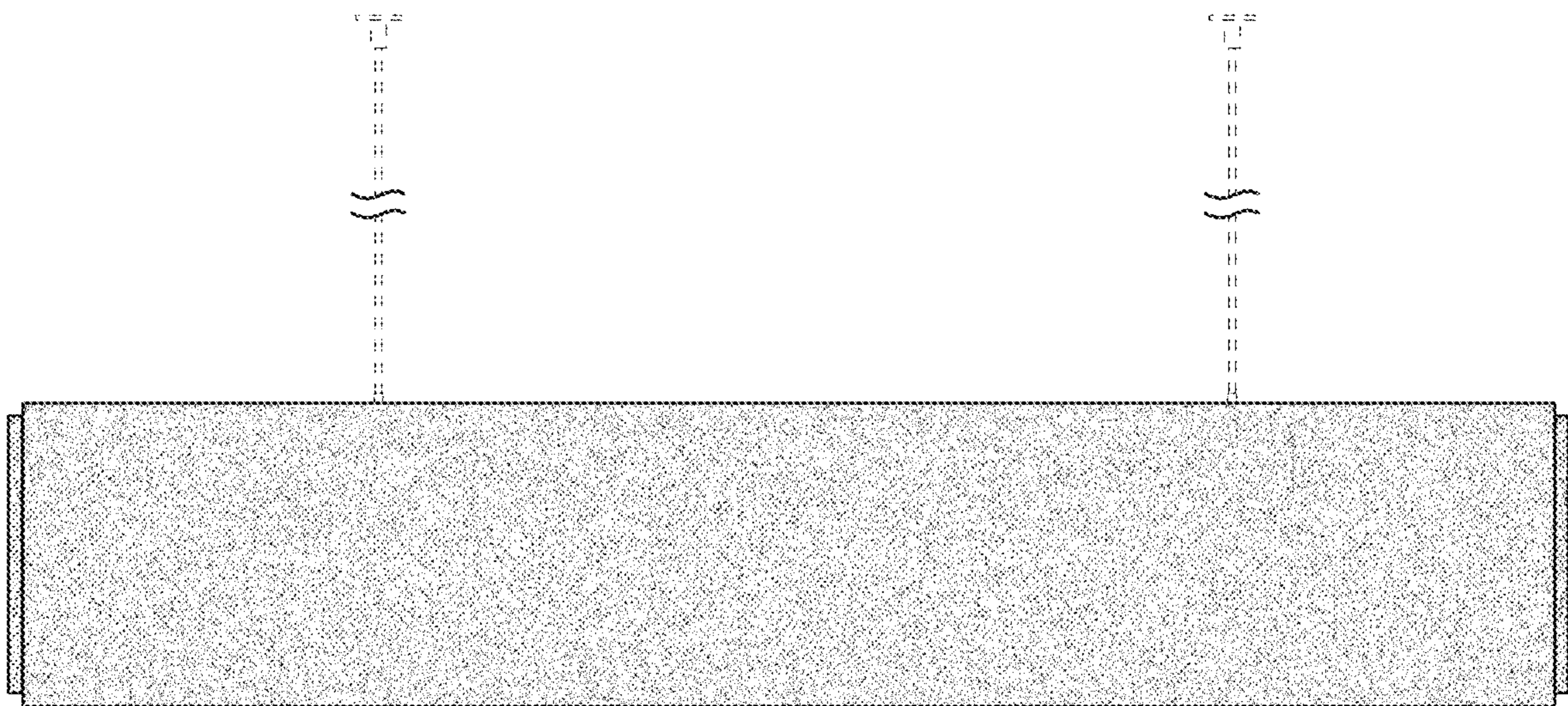


FIG. 15



**FIG. 16**



**FIG. 17**

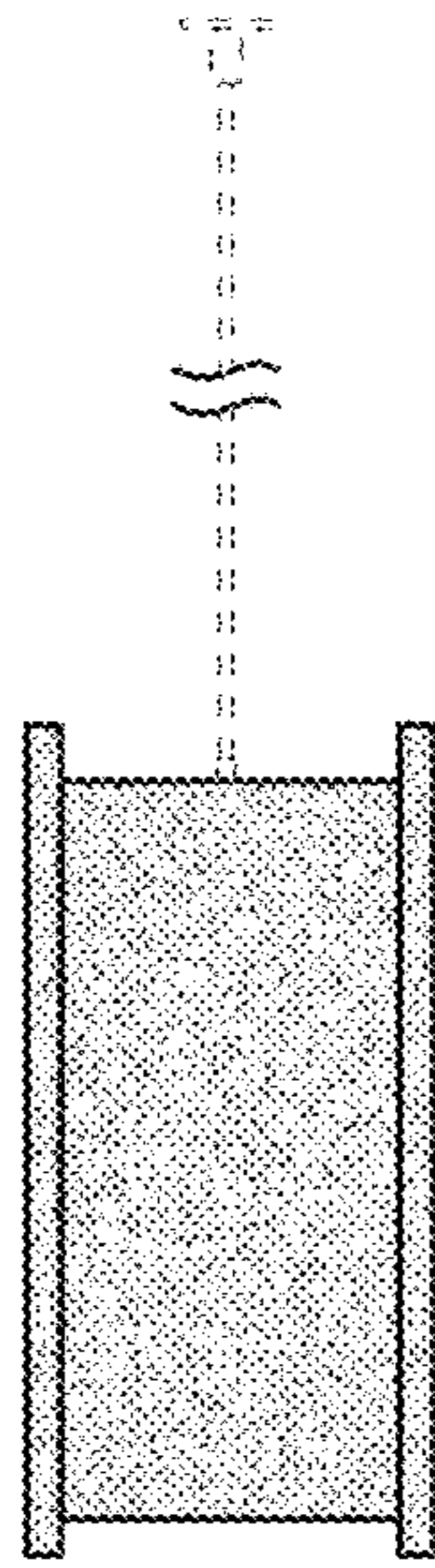


FIG. 18

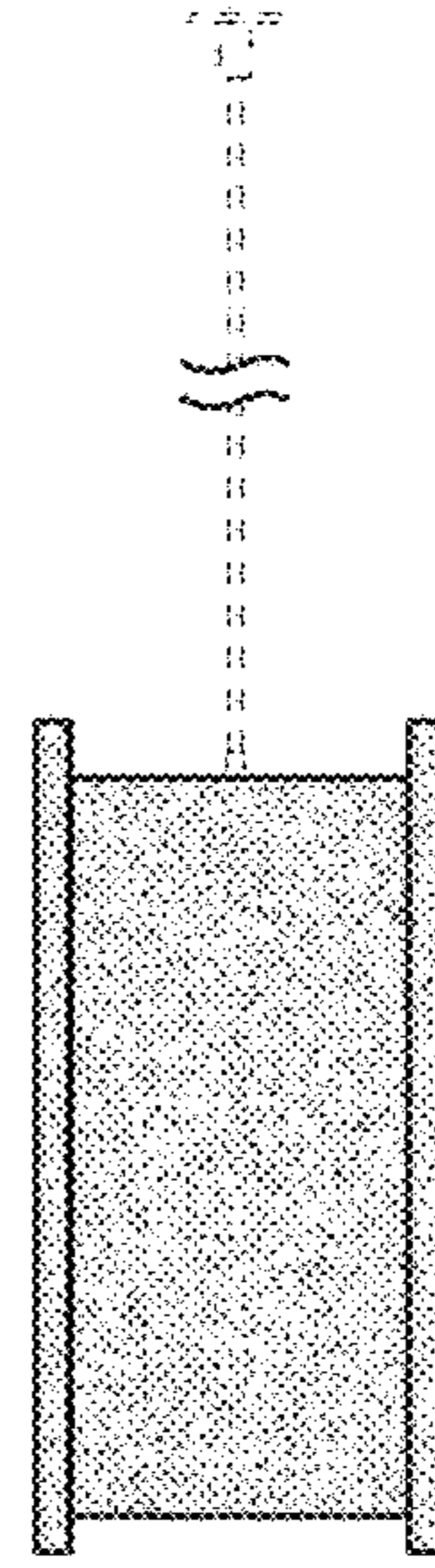


FIG. 19

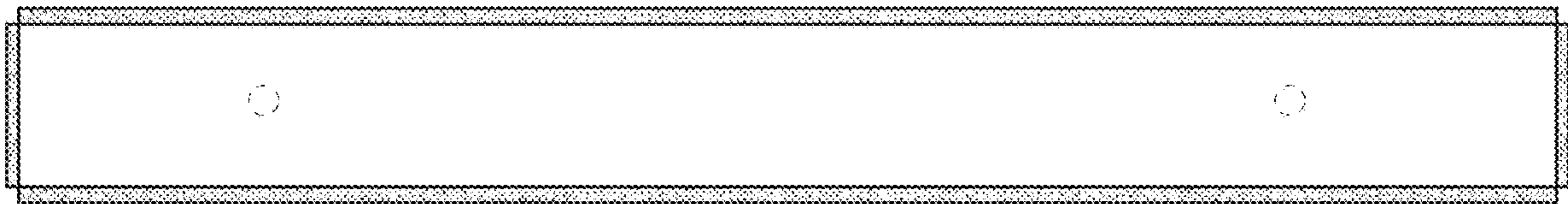


FIG. 20

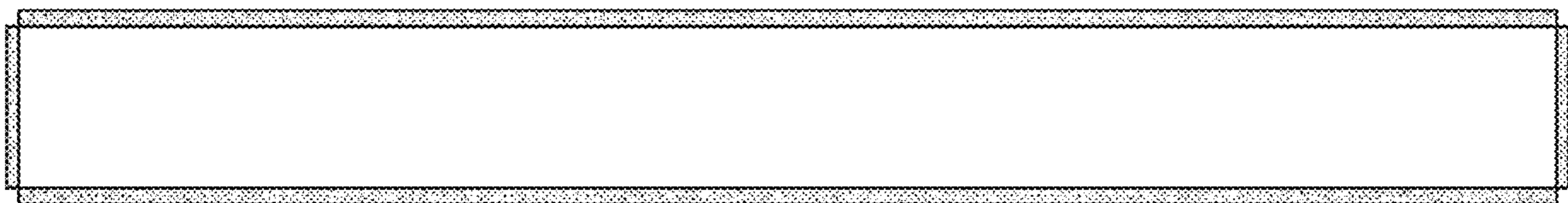


FIG. 21

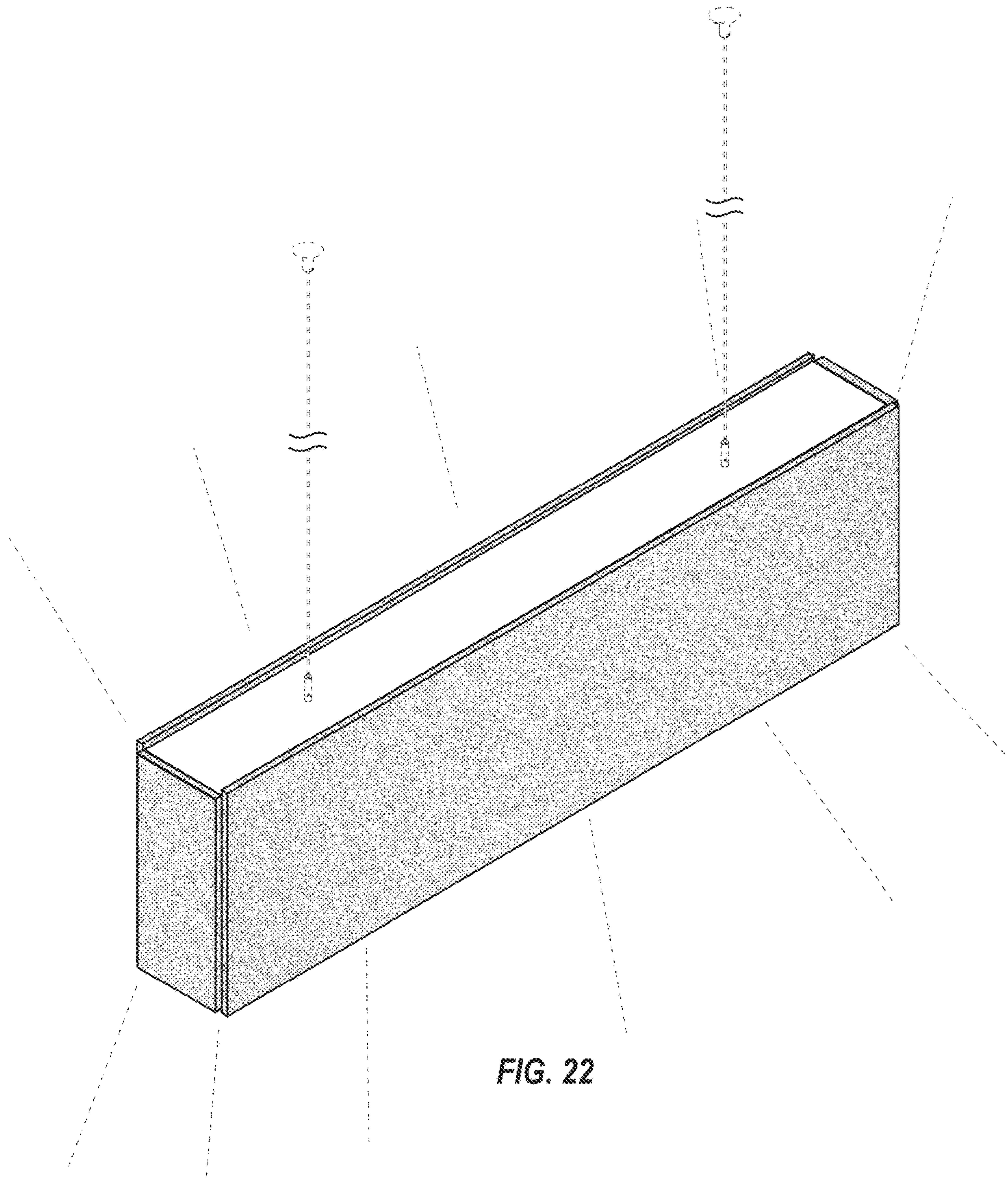


FIG. 22

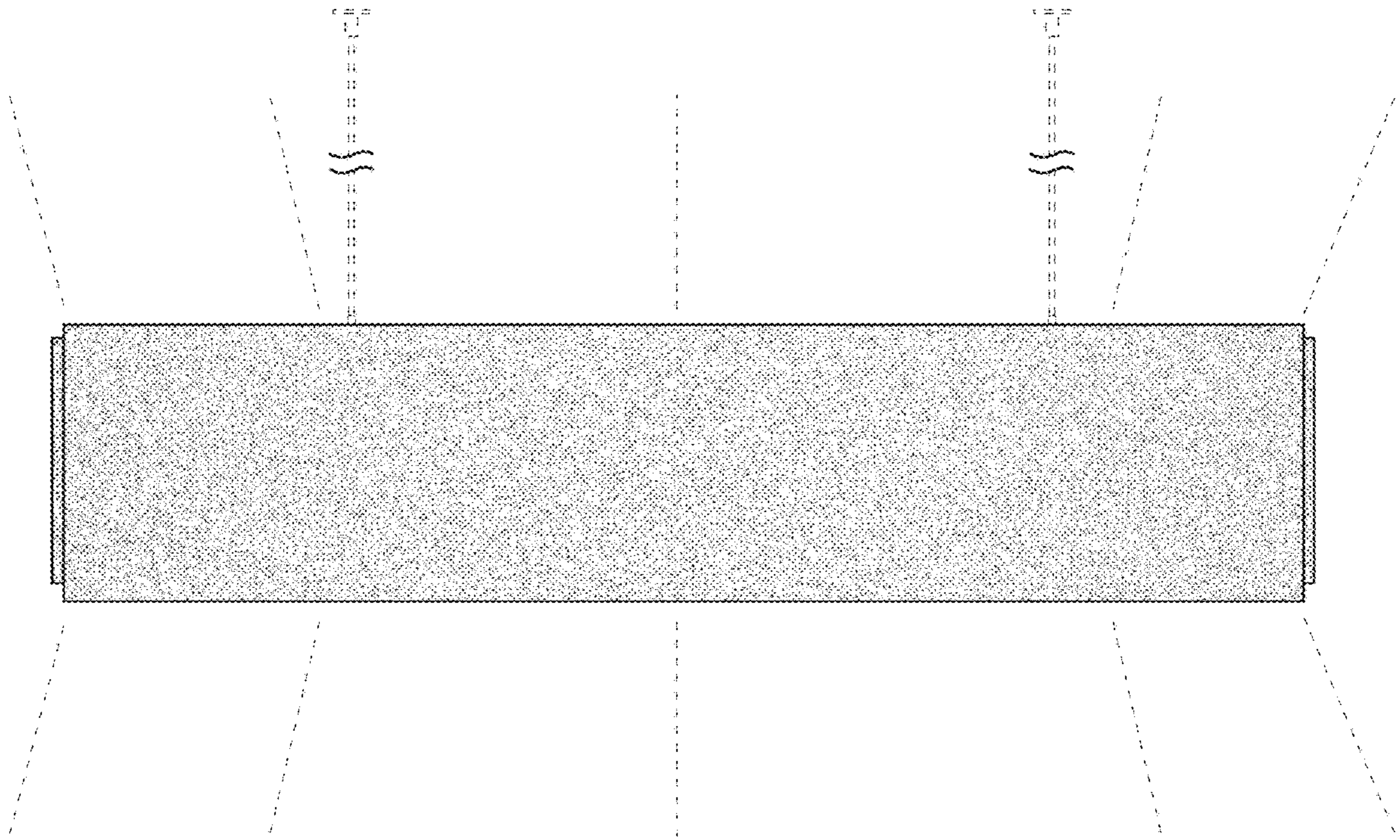


FIG. 23

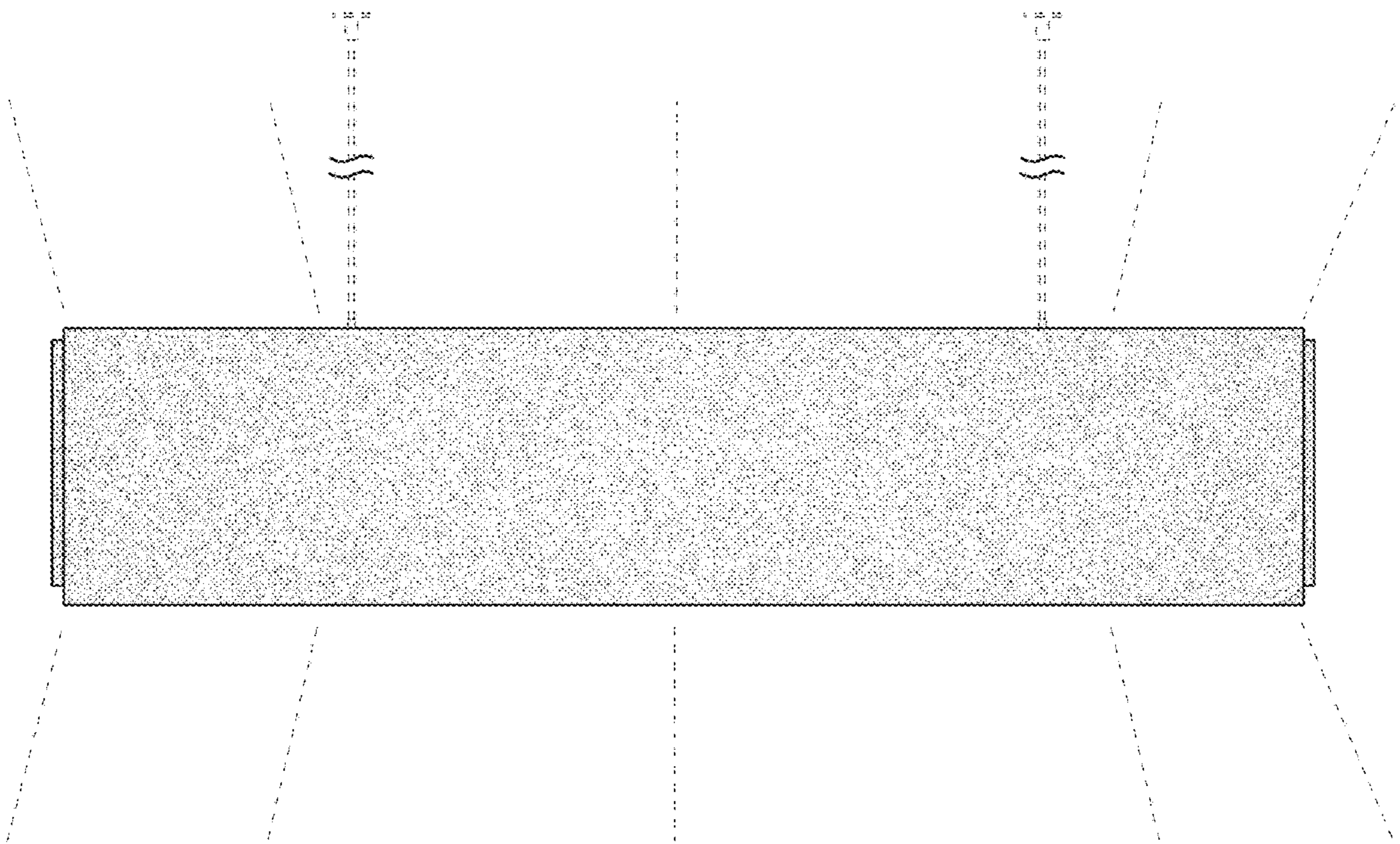


FIG. 24



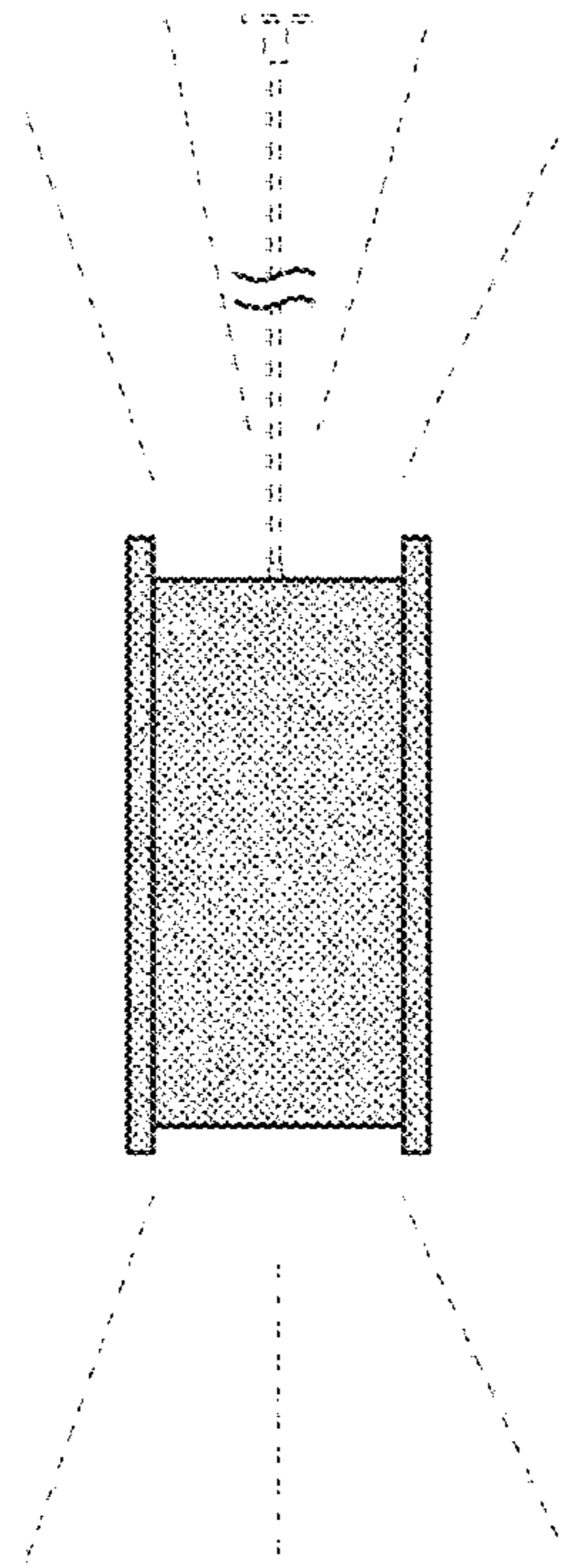


FIG. 25

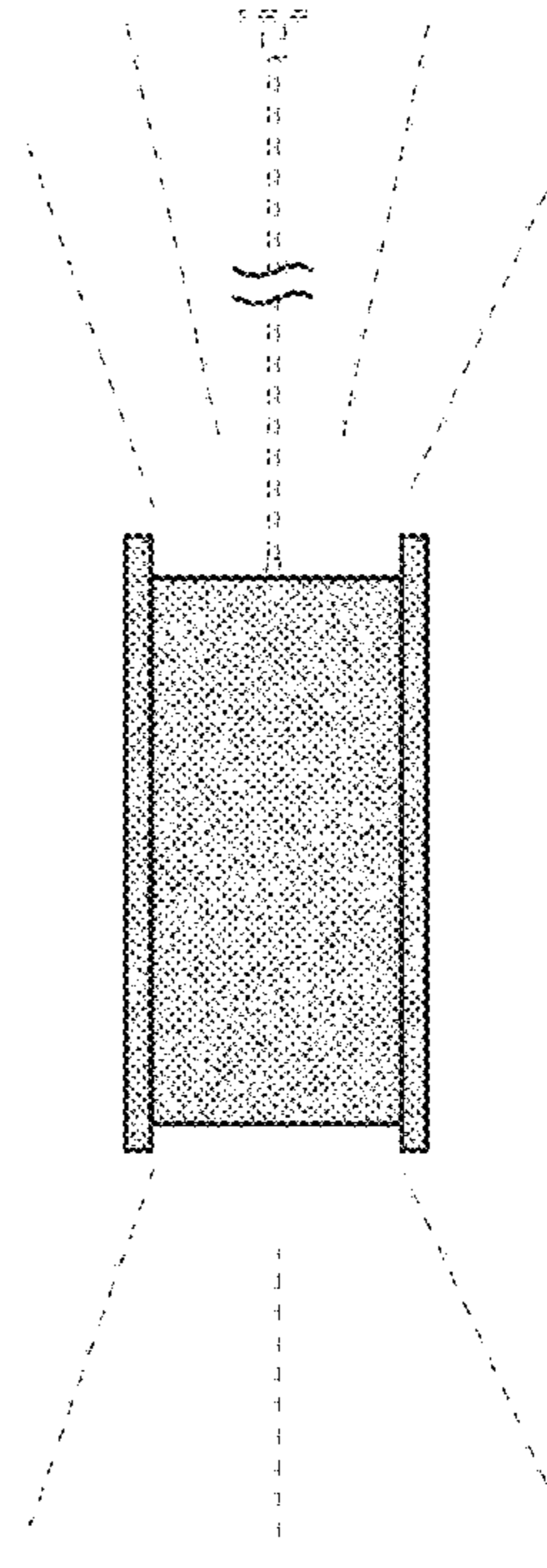


FIG. 26

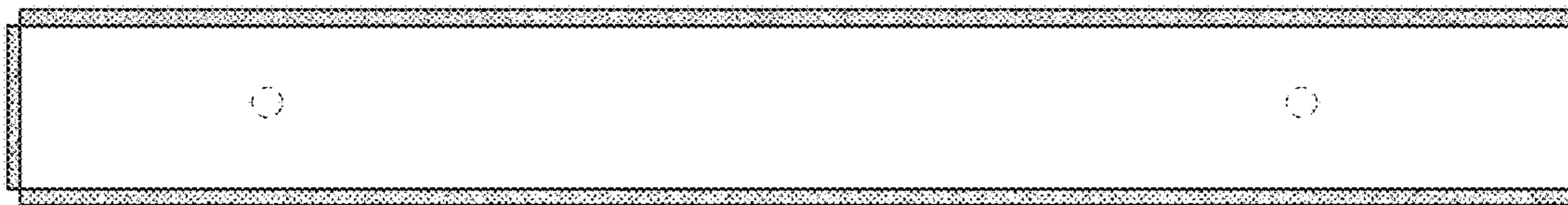


FIG. 27

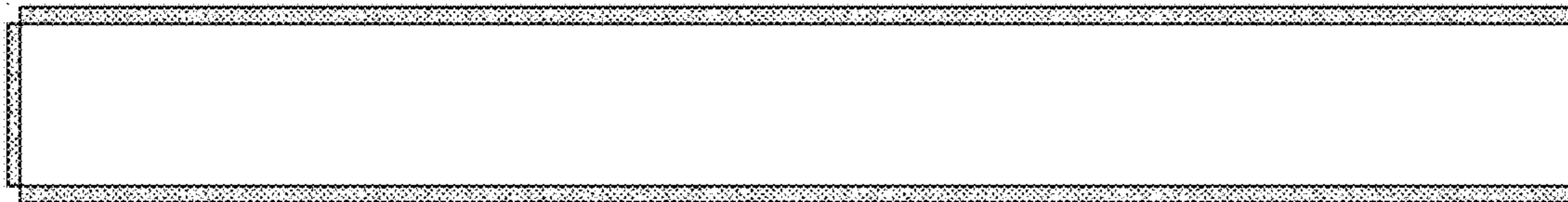


FIG. 28