

US00D914878S

(12) **United States Design Patent** (10) **Patent No.:** **US D914,878 S**
Shelton, IV et al. (45) **Date of Patent:** **** Mar. 30, 2021**

(54) **SURGICAL INSTRUMENT ANVIL**

(71) Applicant: **Ethicon LLC**, Guaynabo, PR (US)

(72) Inventors: **Frederick E. Shelton, IV**, Hillsboro, OH (US); **Jason L. Harris**, Lebanon, OH (US); **Chester O. Baxter, III**, Loveland, OH (US); **Gregory J. Bakos**, Mason, OH (US); **Jerome R. Morgan**, Cincinnati, OH (US)

(73) Assignee: **Ethicon LLC**, Guaynabo, PR (US)

(**) Term: **15 Years**

(21) Appl. No.: **29/660,252**

(22) Filed: **Aug. 20, 2018**

(51) **LOC (13) Cl.** **24-02**

(52) **U.S. Cl.**
 USPC **D24/145**

(58) **Field of Classification Search**
 USPC D24/145-146, 127
 CPC ... A61B 17/10; A61B 17/068; A61B 17/0682;
 A61B 17/072; A61B 17/07207; A61B
 17/105; A61B 17/115; A61B 17/064
 See application file for complete search history.

(56) **References Cited**

U.S. PATENT DOCUMENTS

66,052 A	6/1867	Smith
662,587 A	11/1900	Blake
670,748 A	3/1901	Weddeler
719,487 A	2/1903	Minor
804,229 A	11/1905	Hutchinson
951,393 A	3/1910	Hahn
1,188,721 A	6/1916	Bittner
1,306,107 A	6/1919	Elliott
1,314,601 A	9/1919	McCaskey
1,677,337 A	7/1928	Grove
1,794,907 A	3/1931	Kelly
1,849,427 A	3/1932	Hook
1,944,116 A	1/1934	Stratman
1,954,048 A	4/1934	Jeffrey et al.
2,028,635 A	1/1936	Wappler

2,037,727 A	4/1936	La Chapelle
2,132,295 A	10/1938	Hawkins
2,161,632 A	6/1939	Nattenheimer
D120,434 S	5/1940	Gold
2,211,117 A	8/1940	Hess
2,214,870 A	9/1940	West
2,224,882 A	12/1940	Peck
2,318,379 A	5/1943	Davis et al.
2,329,440 A	9/1943	La Place
2,377,581 A	6/1945	Shaffrey
2,406,389 A	8/1946	Lee
2,441,096 A	5/1948	Happe
2,448,741 A	9/1948	Scott et al.
2,450,527 A	10/1948	Smith
2,491,872 A	12/1949	Neuman
2,507,872 A	5/1950	Unsinger
2,526,902 A	10/1950	Ruble
2,527,256 A	10/1950	Jackson
2,578,686 A	12/1951	Fish
2,638,901 A	5/1953	Sugarbaker
2,674,149 A	4/1954	Benson
2,701,489 A	2/1955	Osborn
2,711,461 A	6/1955	Happe
2,742,955 A	4/1956	Dominguez
2,804,848 A	9/1957	O'Farrell et al.
2,808,482 A	10/1957	Zanichkowsky et al.
2,853,074 A	9/1958	Olson
2,856,192 A	10/1958	Schuster
2,887,004 A	5/1959	Stewart
2,957,353 A	10/1960	Lewis
2,959,974 A	11/1960	Emrick
3,032,769 A	5/1962	Palmer
3,060,972 A	10/1962	Sheldon
3,075,062 A	1/1963	Iaccarino
3,078,465 A	2/1963	Bobrov
3,079,606 A	3/1963	Bobrov et al.
3,080,564 A	3/1963	Strekopitov et al.
3,166,072 A	1/1965	Sullivan, Jr.
3,180,236 A	4/1965	Beckett
3,196,869 A	7/1965	Scholl
3,204,731 A	9/1965	Bent et al.
3,266,494 A	8/1966	Brownrigg et al.
3,269,630 A	8/1966	Fleischer
3,269,631 A	8/1966	Takaro
3,275,211 A	9/1966	Hirsch et al.
3,317,103 A	5/1967	Cullen et al.
3,317,105 A	5/1967	Astafjev et al.
3,357,296 A	12/1967	Lefever
3,359,978 A	12/1967	Smith, Jr.
3,377,893 A	4/1968	Shorb
3,480,193 A	11/1969	Ralston
3,490,675 A	1/1970	Green et al.
3,494,533 A	2/1970	Green et al.

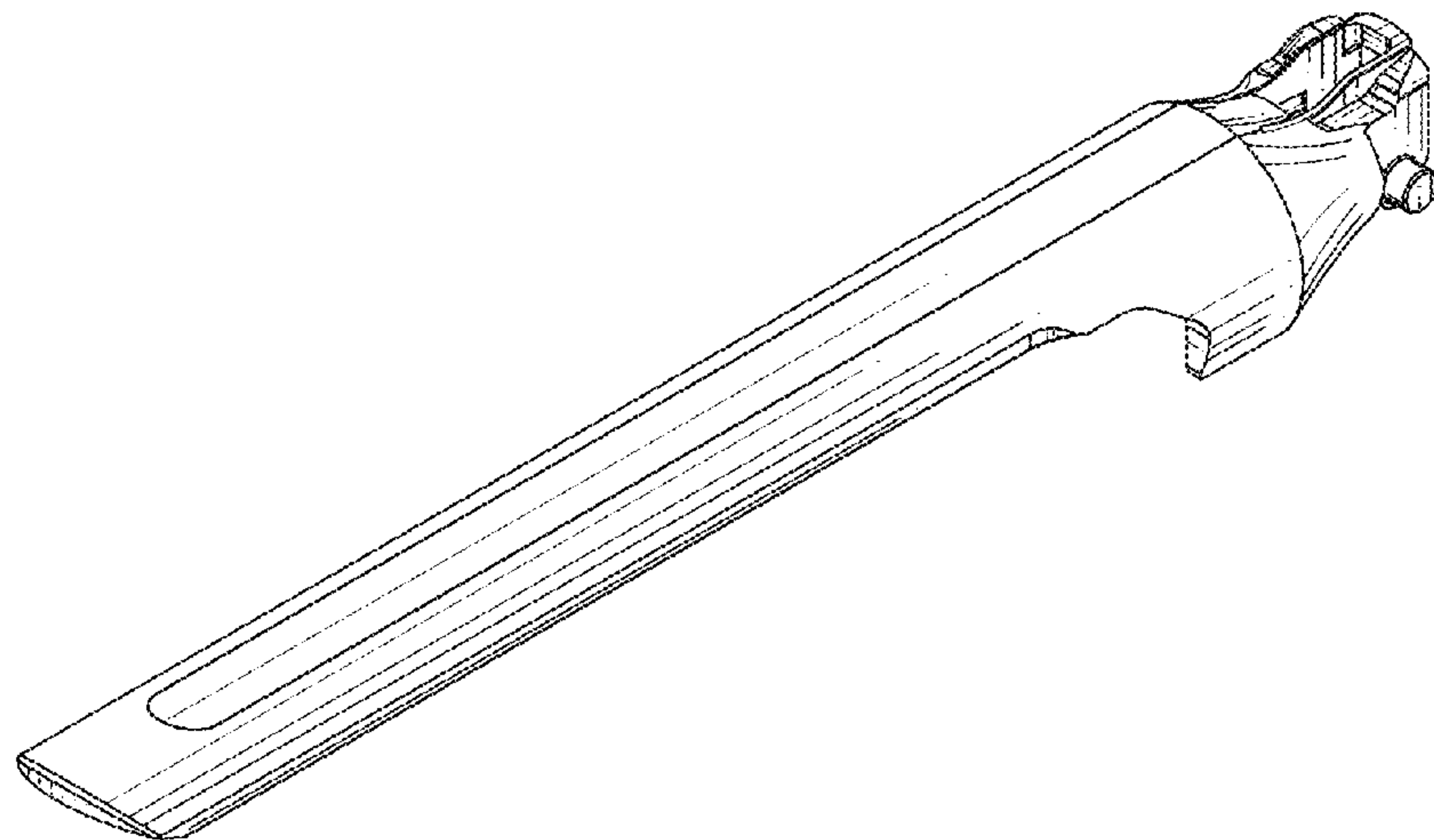

US D914,878 S

3,499,591 A	3/1970	Green	4,198,734 A	4/1980	Brumlik
3,503,396 A	3/1970	Pierie et al.	4,198,982 A	4/1980	Fortner et al.
3,509,629 A	5/1970	Kidokoro	4,207,898 A	6/1980	Becht
3,551,987 A	1/1971	Wilkinson	4,213,562 A	7/1980	Garrett et al.
3,568,675 A	3/1971	Harvey	4,226,242 A	10/1980	Jarvik
3,572,159 A	3/1971	Tschanz	4,239,431 A	12/1980	Davini
3,583,393 A	6/1971	Takahashi	4,241,861 A	12/1980	Fleischer
3,589,589 A	6/1971	Akopov	4,244,372 A	1/1981	Kapitanov et al.
3,598,943 A	8/1971	Barrett	4,250,436 A	2/1981	Weissman
3,608,549 A	9/1971	Merrill	4,261,244 A	4/1981	Becht et al.
3,618,842 A	11/1971	Bryan	4,272,002 A	6/1981	Moshofsky
3,638,652 A	2/1972	Kelley	4,272,662 A	6/1981	Simpson
3,640,317 A	2/1972	Panfili	4,274,304 A	6/1981	Curtiss
3,643,851 A	2/1972	Green et al.	4,274,398 A	6/1981	Scott, Jr.
3,650,453 A	3/1972	Smith, Jr.	4,275,813 A	6/1981	Noiles
3,661,666 A	5/1972	Foster et al.	4,278,091 A	7/1981	Borzone
3,662,939 A	5/1972	Bryan	4,282,573 A	8/1981	Imai et al.
3,688,966 A	9/1972	Perkins et al.	4,289,131 A	9/1981	Mueller
3,695,646 A	10/1972	Mommsen	4,289,133 A	9/1981	Rothfuss
3,709,221 A	1/1973	Riely	4,290,542 A	9/1981	Fedotov et al.
3,717,294 A	2/1973	Green	D261,356 S	10/1981	Robinson
3,726,755 A	4/1973	Shannon	4,293,604 A	10/1981	Campbell
3,727,904 A	4/1973	Gabbey	4,296,654 A	10/1981	Mercer
3,734,207 A	5/1973	Fishbein	4,296,881 A	10/1981	Lee
3,740,994 A	6/1973	De Carlo, Jr.	4,304,236 A	12/1981	Conta et al.
3,744,495 A	7/1973	Johnson	4,305,539 A	12/1981	Korolkov et al.
3,746,002 A	7/1973	Haller	4,312,363 A	1/1982	Rothfuss et al.
3,747,603 A	7/1973	Adler	4,312,685 A	1/1982	Riedl
3,747,692 A	7/1973	Davidson	4,317,451 A	3/1982	Cerwin et al.
3,751,902 A	8/1973	Kingsbury et al.	4,319,576 A	3/1982	Rothfuss
3,752,161 A	8/1973	Bent	4,321,002 A	3/1982	Froehlich
3,799,151 A	3/1974	Fukaumi et al.	4,321,746 A	3/1982	Grinage
3,808,452 A	4/1974	Hutchinson	4,328,839 A	5/1982	Lyons et al.
3,815,476 A	6/1974	Green et al.	4,331,277 A	5/1982	Green
3,819,100 A	6/1974	Noiles et al.	4,340,331 A	7/1982	Savino
3,821,919 A	7/1974	Knohl	4,347,450 A	8/1982	Colligan
3,826,978 A	7/1974	Kelly	4,348,603 A	9/1982	Huber
3,836,171 A	9/1974	Hayashi et al.	4,349,028 A	9/1982	Green
3,837,555 A	9/1974	Green	4,350,151 A	9/1982	Scott
3,841,474 A	10/1974	Maier	4,353,371 A	10/1982	Cosman
3,851,196 A	11/1974	Hinds	4,357,940 A	11/1982	Muller
3,863,639 A	2/1975	Kleaveland	4,361,057 A	11/1982	Kochera
3,863,940 A	2/1975	Cummings	4,366,544 A	12/1982	Shima et al.
3,883,624 A	5/1975	McKenzie et al.	4,369,013 A	1/1983	Abildgaard et al.
3,885,491 A	5/1975	Curtis	4,373,147 A	2/1983	Carlson, Jr.
3,892,228 A	7/1975	Mitsui	4,376,380 A	3/1983	Burgess
3,894,174 A	7/1975	Cartun	4,379,457 A	4/1983	Gravener et al.
3,902,247 A	9/1975	Fleer et al.	4,380,312 A	4/1983	Landrus
3,940,844 A	3/1976	Colby et al.	4,382,326 A	5/1983	Rabuse
3,944,163 A	3/1976	Hayashi et al.	4,383,634 A	5/1983	Green
3,950,686 A	4/1976	Randall	4,393,728 A	7/1983	Larson et al.
3,952,747 A	4/1976	Kimmell, Jr.	4,394,613 A	7/1983	Cole
3,955,581 A	5/1976	Spasiano et al.	4,396,139 A	8/1983	Hall et al.
3,959,879 A	6/1976	Sellers	4,397,311 A	8/1983	Kanshin et al.
RE28,932 E	8/1976	Noiles et al.	4,402,445 A	9/1983	Green
3,972,734 A	8/1976	King	4,406,621 A	9/1983	Bailey
3,981,051 A	9/1976	Brumlik	4,408,692 A	10/1983	Sigel et al.
4,025,216 A	5/1977	Hives	4,409,057 A	10/1983	Molenda et al.
4,027,746 A	6/1977	Kine	4,415,112 A	11/1983	Green
4,034,143 A	7/1977	Sweet	4,416,276 A	11/1983	Newton et al.
4,038,987 A	8/1977	Komiya	4,417,890 A	11/1983	Dennehey et al.
4,054,108 A	10/1977	Gill	4,423,456 A	12/1983	Zaidenweber
4,060,089 A	11/1977	Noiles	4,428,376 A	1/1984	Mericle
4,066,133 A	1/1978	Voss	4,429,695 A	2/1984	Green
4,085,337 A	4/1978	Moeller	4,430,997 A	2/1984	DiGiovanni et al.
4,100,820 A	7/1978	Evet	4,434,796 A	3/1984	Karapetian et al.
4,106,446 A	8/1978	Yamada et al.	4,438,659 A	3/1984	Desplats
4,106,620 A	8/1978	Brimmer et al.	4,442,964 A	4/1984	Becht
4,108,211 A	8/1978	Tanaka	4,448,194 A	5/1984	DiGiovanni et al.
4,111,206 A	9/1978	Vishnevsky et al.	4,451,743 A	5/1984	Suzuki et al.
4,127,227 A	11/1978	Green	4,452,376 A	6/1984	Klieman et al.
4,129,059 A	12/1978	Van Eck	4,454,887 A	6/1984	Kruger
4,132,146 A	1/1979	Uhlig	4,459,519 A	7/1984	Erdman
4,135,517 A	1/1979	Reale	4,461,305 A	7/1984	Cibley
4,154,122 A	5/1979	Severin	4,467,805 A	8/1984	Fukuda
4,169,990 A	10/1979	Lerdman	4,468,597 A	8/1984	Baumard et al.
4,180,285 A	12/1979	Reneau	4,469,481 A	9/1984	Kobayashi
4,185,701 A	1/1980	Boys	4,470,414 A	9/1984	Imagawa et al.
4,190,042 A	2/1980	Sinnreich	4,471,780 A	9/1984	Menges et al.

US D914,878 S

Page 3

4,471,781 A	9/1984	Di Giovanni et al.	4,634,419 A	1/1987	Kreizman et al.
4,473,077 A	9/1984	Noiles et al.	4,635,638 A	1/1987	Weintraub et al.
4,475,679 A	10/1984	Fleury, Jr.	4,641,076 A	2/1987	Linden
4,478,220 A	10/1984	Di Giovanni et al.	4,642,618 A	2/1987	Johnson et al.
4,480,641 A	11/1984	Failla et al.	4,643,173 A	2/1987	Bell et al.
4,483,562 A	11/1984	Schoolman	4,643,731 A	2/1987	Eckenhoff
4,485,816 A	12/1984	Krumme	4,646,722 A	3/1987	Silverstein et al.
4,485,817 A	12/1984	Swiggett	4,646,745 A	3/1987	Noiles
4,486,928 A	12/1984	Tucker et al.	4,651,734 A	3/1987	Doss et al.
4,488,523 A	12/1984	Shichman	4,652,820 A	3/1987	Maresca
4,489,875 A	12/1984	Crawford et al.	4,654,028 A	3/1987	Suma
4,493,983 A	1/1985	Taggart	4,655,222 A	4/1987	Florez et al.
4,494,057 A	1/1985	Hotta	4,662,555 A	5/1987	Thornton
4,499,895 A	2/1985	Takayama	4,663,874 A	5/1987	Sano et al.
4,500,024 A	2/1985	DiGiovanni et al.	4,664,305 A	5/1987	Blake, III et al.
D278,081 S	3/1985	Green	4,665,916 A	5/1987	Green
4,503,842 A	3/1985	Takayama	4,667,674 A	5/1987	Korthoff et al.
4,505,272 A	3/1985	Utyamyshev et al.	4,669,647 A	6/1987	Storace
4,505,273 A	3/1985	Braun et al.	4,671,278 A	6/1987	Chin
4,505,414 A	3/1985	Filipi	4,671,280 A	6/1987	Dorband et al.
4,506,671 A	3/1985	Green	4,671,445 A	6/1987	Barker et al.
4,512,038 A	4/1985	Alexander et al.	4,672,964 A	6/1987	Dee et al.
4,520,817 A	6/1985	Green	4,675,944 A	6/1987	Wells
4,522,327 A	6/1985	Korthoff et al.	4,676,245 A	6/1987	Fukuda
4,526,174 A	7/1985	Froehlich	4,679,460 A	7/1987	Yoshigai
4,527,724 A	7/1985	Chow et al.	4,679,719 A	7/1987	Kramer
4,530,357 A	7/1985	Pawloski et al.	4,684,051 A	8/1987	Akopov et al.
4,530,453 A	7/1985	Green	4,688,555 A	8/1987	Wardle
4,531,522 A	7/1985	Bedi et al.	4,691,703 A	9/1987	Auth et al.
4,532,927 A	8/1985	Miksza, Jr.	4,693,248 A	9/1987	Failla
4,540,202 A	9/1985	Amphoux et al.	4,698,579 A	10/1987	Richter et al.
4,548,202 A	10/1985	Duncan	4,700,703 A	10/1987	Resnick et al.
4,556,058 A	12/1985	Green	4,705,038 A	11/1987	Sjostrom et al.
4,560,915 A	12/1985	Soultanian	4,708,141 A	11/1987	Inoue et al.
4,565,109 A	1/1986	Tsay	4,709,120 A	11/1987	Pearson
4,565,189 A	1/1986	Mabuchi	4,715,520 A	12/1987	Roehr, Jr. et al.
4,566,620 A	1/1986	Green et al.	4,719,917 A	1/1988	Barrows et al.
4,569,346 A	2/1986	Poirier	4,721,099 A	1/1988	Chikama
4,569,469 A	2/1986	Mongeon et al.	4,722,340 A	2/1988	Takayama et al.
4,571,213 A	2/1986	Ishimoto	4,724,840 A	2/1988	McVay et al.
4,573,468 A	3/1986	Conta et al.	4,727,308 A	2/1988	Huljak et al.
4,573,469 A	3/1986	Golden et al.	4,728,020 A	3/1988	Green et al.
4,573,622 A	3/1986	Green et al.	4,728,876 A	3/1988	Mongeon et al.
4,576,165 A	3/1986	Green et al.	4,729,260 A	3/1988	Dudden
4,576,167 A	3/1986	Noiles	4,730,726 A	3/1988	Holzwarth
4,580,712 A	4/1986	Green	4,741,336 A	5/1988	Failla et al.
4,585,153 A	4/1986	Failla et al.	4,743,214 A	5/1988	Tai-Cheng
4,586,501 A	5/1986	Claracq	4,744,363 A	5/1988	Hasson
4,586,502 A	5/1986	Bedi et al.	4,747,820 A	5/1988	Hornlein et al.
4,589,416 A	5/1986	Green	4,750,902 A	6/1988	Wuchinich et al.
4,589,582 A	5/1986	Bilotti	4,752,024 A	6/1988	Green et al.
4,589,870 A	5/1986	Citrin et al.	4,754,909 A	7/1988	Barker et al.
4,591,085 A	5/1986	Di Giovanni	4,755,070 A	7/1988	Cerutti
RE32,214 E	7/1986	Schramm	4,761,326 A	8/1988	Barnes et al.
4,597,753 A	7/1986	Turley	4,763,669 A	8/1988	Jaeger
4,600,037 A	7/1986	Hatten	4,767,044 A	8/1988	Green
4,604,786 A	8/1986	Howie, Jr.	D297,764 S	9/1988	Hunt et al.
4,605,001 A	8/1986	Rothfuss et al.	4,773,420 A	9/1988	Green
4,605,004 A	8/1986	Di Giovanni et al.	4,777,780 A	10/1988	Holzwarth
4,606,343 A	8/1986	Conta et al.	4,781,186 A	11/1988	Simpson et al.
4,607,636 A	8/1986	Kula et al.	4,784,137 A	11/1988	Kulik et al.
4,607,638 A	8/1986	Crainich	4,787,387 A	11/1988	Burbank, III et al.
4,608,981 A	9/1986	Rothfuss et al.	4,788,485 A	11/1988	Kawagishi et al.
4,610,250 A	9/1986	Green	D298,967 S	12/1988	Hunt
4,610,383 A	9/1986	Rothfuss et al.	4,790,225 A	12/1988	Moody et al.
4,612,933 A	9/1986	Brinkerhoff et al.	4,790,314 A	12/1988	Weaver
D286,180 S	10/1986	Korthoff	4,805,617 A	2/1989	Bedi et al.
D286,442 S	10/1986	Korthoff et al.	4,805,823 A	2/1989	Rothfuss
4,617,893 A	10/1986	Donner et al.	4,807,628 A	2/1989	Peters et al.
4,617,914 A	10/1986	Ueda	4,809,695 A	3/1989	Gwathmey et al.
4,619,262 A	10/1986	Taylor	4,815,460 A	3/1989	Porat et al.
4,619,391 A	10/1986	Sharkany et al.	4,817,643 A	4/1989	Olson
D287,278 S	12/1986	Spreckelmeier	4,817,847 A	4/1989	Redtenbacher et al.
4,628,459 A	12/1986	Shinohara et al.	4,819,853 A	4/1989	Green
4,628,636 A	12/1986	Folger	4,821,939 A	4/1989	Green
4,629,107 A	12/1986	Fedotov et al.	4,827,911 A	5/1989	Broadwin et al.
4,632,290 A	12/1986	Green et al.	4,828,542 A	5/1989	Hermann
4,633,861 A	1/1987	Chow et al.	4,828,944 A	5/1989	Yabe et al.
4,633,874 A	1/1987	Chow et al.	4,830,855 A	5/1989	Stewart

US D914,878 S

4,832,158 A	5/1989	Farrar et al.	5,018,657 A	5/1991	Pedlick et al.
4,833,937 A	5/1989	Nagano	5,024,652 A	6/1991	Dumeneq et al.
4,834,096 A	5/1989	Oh et al.	5,024,671 A	6/1991	Tu et al.
4,834,720 A	5/1989	Blinkhorn	5,025,559 A	6/1991	McCullough
4,838,859 A	6/1989	Strassmann	5,027,834 A	7/1991	Pruitt
4,844,068 A	7/1989	Arata et al.	5,030,226 A	7/1991	Green et al.
4,848,637 A	7/1989	Pruitt	5,031,814 A	7/1991	Tompkins et al.
4,856,078 A	8/1989	Konopka	5,035,040 A	7/1991	Kerrigan et al.
4,860,644 A	8/1989	Kohl et al.	5,037,018 A	8/1991	Matsuda et al.
4,862,891 A	9/1989	Smith	5,038,109 A	8/1991	Goble et al.
4,863,423 A	9/1989	Wallace	5,038,247 A	8/1991	Kelley et al.
4,865,030 A	9/1989	Polyak	5,040,715 A	8/1991	Green et al.
4,868,530 A	9/1989	Ahs	5,042,707 A	8/1991	Taheri
4,869,414 A	9/1989	Green et al.	5,060,658 A	10/1991	Dejter, Jr. et al.
4,869,415 A	9/1989	Fox	5,061,269 A	10/1991	Muller
4,873,977 A	10/1989	Avant et al.	5,062,491 A	11/1991	Takeshima et al.
4,875,486 A	10/1989	Rapoport et al.	5,062,563 A	11/1991	Green et al.
4,880,015 A	11/1989	Nierman	5,065,929 A	11/1991	Schulze et al.
4,890,613 A	1/1990	Golden et al.	5,071,052 A	12/1991	Rodak et al.
4,892,244 A	1/1990	Fox et al.	5,071,430 A	12/1991	de Salis et al.
4,893,622 A	1/1990	Green et al.	5,074,454 A	12/1991	Peters
4,894,051 A	1/1990	Shiber	5,077,506 A	12/1991	Krause
4,896,584 A	1/1990	Stoll et al.	5,079,006 A	1/1992	Urquhart
4,896,678 A	1/1990	Ogawa	5,080,556 A	1/1992	Carreno
4,900,303 A	2/1990	Lemelson	5,083,695 A	1/1992	Foslien et al.
4,903,697 A	2/1990	Resnick et al.	5,084,057 A	1/1992	Green et al.
4,909,789 A	3/1990	Taguchi et al.	5,088,979 A	2/1992	Filipi et al.
4,915,100 A	4/1990	Green	5,088,997 A	2/1992	Delahuerge et al.
4,919,679 A	4/1990	Averill et al.	5,089,606 A	2/1992	Cole et al.
4,921,479 A	5/1990	Grayzel	5,094,247 A	3/1992	Hernandez et al.
4,925,082 A	5/1990	Kim	5,098,004 A	3/1992	Kerrigan
4,928,699 A	5/1990	Sasai	5,098,360 A	3/1992	Hirota
4,930,503 A	6/1990	Pruitt	5,100,042 A	3/1992	Gravener et al.
4,930,674 A	6/1990	Barak	5,100,420 A	3/1992	Green et al.
4,931,047 A	6/1990	Broadwin et al.	5,104,025 A	4/1992	Main et al.
4,931,737 A	6/1990	Hishiki	5,104,397 A	4/1992	Vasconcelos et al.
4,932,960 A	6/1990	Green et al.	5,104,400 A	4/1992	Berguer et al.
4,933,800 A	6/1990	Yang	5,106,008 A	4/1992	Tompkins et al.
4,933,843 A	6/1990	Scheller et al.	5,108,368 A	4/1992	Hammerslag et al.
D309,350 S	7/1990	Sutherland et al.	5,109,722 A	5/1992	Hufnagle et al.
4,938,408 A	7/1990	Bedi et al.	5,111,987 A	5/1992	Moeinzadeh et al.
4,941,623 A	7/1990	Pruitt	5,116,349 A	5/1992	Aranyi
4,943,182 A	7/1990	Hoblingre	D327,323 S	6/1992	Hunt
4,944,443 A	7/1990	Odds et al.	5,119,009 A	6/1992	McCaleb et al.
4,946,067 A	8/1990	Kelsall	5,122,156 A	6/1992	Granger et al.
4,948,327 A	8/1990	Crupi, Jr.	5,124,990 A	6/1992	Williamson
4,949,707 A	8/1990	Levahn et al.	5,129,570 A	7/1992	Schulze et al.
4,951,860 A	8/1990	Peters et al.	5,129,570 A	8/1992	Nobis et al.
4,951,861 A	8/1990	Schulze et al.	5,137,198 A	8/1992	Nobis et al.
4,954,960 A	9/1990	Lo et al.	5,139,513 A	8/1992	Segato
4,955,959 A	9/1990	Tompkins et al.	5,141,144 A	8/1992	Foslien et al.
4,957,212 A	9/1990	Duck et al.	5,142,932 A	9/1992	Moya et al.
4,962,877 A	10/1990	Hervas	5,151,102 A	9/1992	Kamiyama et al.
4,964,559 A	10/1990	Deniega et al.	5,155,941 A	10/1992	Takahashi et al.
4,964,863 A	10/1990	Kanshin et al.	5,156,315 A	10/1992	Green et al.
4,965,709 A	10/1990	Ngo	5,156,609 A	10/1992	Nakao et al.
4,970,656 A	11/1990	Lo et al.	5,156,614 A	10/1992	Green et al.
4,973,274 A	11/1990	Hirukawa	5,158,222 A	10/1992	Green et al.
4,973,302 A	11/1990	Armour et al.	5,158,567 A	10/1992	Green
4,978,049 A	12/1990	Green	D330,699 S	11/1992	Gill
4,978,333 A	12/1990	Broadwin et al.	5,163,598 A	11/1992	Peters et al.
4,979,952 A	12/1990	Kubota et al.	5,168,605 A	12/1992	Bartlett
4,984,564 A	1/1991	Yuen	5,170,925 A	12/1992	Madden et al.
4,986,808 A	1/1991	Broadwin et al.	5,171,247 A	12/1992	Hughett et al.
4,987,049 A	1/1991	Komamura et al.	5,171,249 A	12/1992	Stefanchik et al.
4,988,334 A	1/1991	Hornlein et al.	5,171,253 A	12/1992	Klieman
4,995,877 A	2/1991	Ams et al.	5,173,053 A	12/1992	Swanson et al.
4,995,959 A	2/1991	Metzner	5,173,133 A	12/1992	Morin et al.
4,996,975 A	3/1991	Nakamura	5,176,677 A	1/1993	Wuchinich
5,001,649 A	3/1991	Lo et al.	5,176,688 A	1/1993	Narayan et al.
5,002,543 A	3/1991	Bradshaw et al.	5,181,514 A	1/1993	Solomon et al.
5,002,553 A	3/1991	Shiber	5,187,422 A	2/1993	Izenbaard et al.
5,005,754 A	4/1991	Van Overloop	5,188,102 A	2/1993	Idemoto et al.
5,009,661 A	4/1991	Michelson	5,188,111 A	2/1993	Yates et al.
5,012,411 A	4/1991	Policastro et al.	5,190,517 A	3/1993	Zieve et al.
5,014,898 A	5/1991	Heidrich	5,190,544 A	3/1993	Chapman et al.
5,014,899 A	5/1991	Presty et al.	5,190,560 A	3/1993	Woods et al.
5,015,227 A	5/1991	Broadwin et al.	5,190,657 A	3/1993	Heagle et al.
5,018,515 A	5/1991	Gilman	5,192,288 A	3/1993	Thompson et al.
			5,193,731 A	3/1993	Aranyi

US D914,878 S

5,195,505 A	3/1993	Josefsen	5,308,576 A	5/1994	Green et al.
5,195,968 A	3/1993	Lundquist et al.	5,309,387 A	5/1994	Mori et al.
5,197,648 A	3/1993	Gingold	5,309,927 A	5/1994	Welch
5,197,649 A	3/1993	Bessler et al.	5,312,023 A	5/1994	Green et al.
5,197,966 A	3/1993	Sommerkamp	5,312,024 A	5/1994	Grant et al.
5,197,970 A	3/1993	Green et al.	5,312,329 A	5/1994	Beaty et al.
5,200,280 A	4/1993	Karasa	5,313,935 A	5/1994	Kortenbach et al.
5,201,750 A	4/1993	Hocherl et al.	5,313,967 A	5/1994	Lieber et al.
5,205,459 A	4/1993	Brinkerhoff et al.	5,314,424 A	5/1994	Nicholas
5,207,672 A	5/1993	Roth et al.	5,314,445 A	5/1994	Heidmueller nee Degwitz et al.
5,207,697 A	5/1993	Carusillo et al.	5,314,466 A	5/1994	Stern et al.
5,209,747 A	5/1993	Knoepfler	5,318,221 A	6/1994	Green et al.
5,209,756 A	5/1993	Seedhom et al.	5,320,627 A	6/1994	Sorensen et al.
5,211,649 A	5/1993	Kohler et al.	D348,930 S	7/1994	Olson
5,211,655 A	5/1993	Hasson	5,326,013 A	7/1994	Green et al.
5,217,457 A	6/1993	Delahuerga et al.	5,329,923 A	7/1994	Lundquist
5,217,478 A	6/1993	Rexroth	5,330,487 A	7/1994	Thornton et al.
5,219,111 A	6/1993	Bilotti et al.	5,330,502 A	7/1994	Hassler et al.
5,220,269 A	6/1993	Chen et al.	5,331,971 A	7/1994	Bales et al.
5,221,036 A	6/1993	Takase	5,332,142 A	7/1994	Robinson et al.
5,221,281 A	6/1993	Klicek	5,333,422 A	8/1994	Warren et al.
5,222,945 A	6/1993	Basnight	5,333,772 A	8/1994	Rothfuss et al.
5,222,963 A	6/1993	Brinkerhoff et al.	5,333,773 A	8/1994	Main et al.
5,222,975 A	6/1993	Crainich	5,334,183 A	8/1994	Wuchinich
5,222,976 A	6/1993	Yoon	5,336,130 A	8/1994	Ray
5,223,675 A	6/1993	Taft	5,336,229 A	8/1994	Noda
D338,729 S	8/1993	Sprecklemeier et al.	5,336,232 A	8/1994	Green et al.
5,234,447 A	8/1993	Kaster et al.	5,338,317 A	8/1994	Hasson et al.
5,236,269 A	8/1993	Handy	5,339,799 A	8/1994	Kami et al.
5,236,424 A	8/1993	Imran	5,341,724 A	8/1994	Vatel
5,236,440 A	8/1993	Hlavacek	5,341,807 A	8/1994	Nardella
5,239,981 A	8/1993	Anaplotis	5,341,810 A	8/1994	Dardel
5,240,163 A	8/1993	Stein et al.	5,342,380 A	8/1994	Hood
5,242,456 A	9/1993	Nash et al.	5,342,381 A	8/1994	Tidemand
5,242,457 A	9/1993	Akopov et al.	5,342,385 A	8/1994	Norelli et al.
5,244,462 A	9/1993	Delahuerga et al.	5,342,395 A	8/1994	Jarrett et al.
5,246,156 A	9/1993	Rothfuss et al.	5,342,396 A	8/1994	Cook
5,246,443 A	9/1993	Mai	5,343,382 A	8/1994	Hale et al.
5,253,793 A	10/1993	Green et al.	5,343,391 A	8/1994	Mushabac
5,258,007 A	11/1993	Spetzler et al.	5,344,059 A	9/1994	Green et al.
5,258,008 A	11/1993	Wilk	5,344,060 A	9/1994	Gravener et al.
5,258,009 A	11/1993	Connors	5,344,454 A	9/1994	Clarke et al.
5,258,010 A	11/1993	Green et al.	5,346,504 A	9/1994	Ortiz et al.
5,258,012 A	11/1993	Luscombe et al.	5,348,259 A	9/1994	Blanco et al.
5,259,366 A	11/1993	Reydel et al.	5,350,355 A	9/1994	Sklar
5,259,835 A	11/1993	Clark et al.	5,350,388 A	9/1994	Epstein
5,260,637 A	11/1993	Pizzi	5,350,391 A	9/1994	Iacovelli
5,261,135 A	11/1993	Mitchell	5,350,400 A	9/1994	Esposito et al.
5,261,877 A	11/1993	Fine et al.	5,352,229 A	10/1994	Goble et al.
5,261,922 A	11/1993	Hood	5,352,235 A	10/1994	Koros et al.
5,263,629 A	11/1993	Trumbull et al.	5,352,238 A	10/1994	Green et al.
5,263,937 A	11/1993	Shipp	5,353,798 A	10/1994	Sieben
5,263,973 A	11/1993	Cook	5,354,250 A	10/1994	Christensen
5,264,218 A	11/1993	Rogozinski	5,354,303 A	10/1994	Spaeth et al.
5,268,622 A	12/1993	Philipp	5,356,006 A	10/1994	Alpern et al.
5,271,543 A	12/1993	Grant et al.	5,356,064 A	10/1994	Green et al.
5,271,544 A	12/1993	Fox et al.	5,358,506 A	10/1994	Green et al.
RE34,519 E	1/1994	Fox et al.	5,358,510 A	10/1994	Luscombe et al.
5,275,322 A	1/1994	Brinkerhoff et al.	5,359,231 A	10/1994	Flowers et al.
5,275,323 A	1/1994	Schulze et al.	D352,780 S	11/1994	Glaeser et al.
5,275,608 A	1/1994	Forman et al.	5,359,993 A	11/1994	Slater et al.
5,279,416 A	1/1994	Malec et al.	5,360,305 A	11/1994	Kerrigan
5,281,216 A	1/1994	Klicek	5,360,428 A	11/1994	Hutchinson, Jr.
5,282,806 A	2/1994	Haber et al.	5,361,902 A	11/1994	Abidin et al.
5,282,826 A	2/1994	Quadri	5,364,001 A	11/1994	Bryan
5,282,829 A	2/1994	Hermes	5,364,002 A	11/1994	Green et al.
5,284,128 A	2/1994	Hart	5,364,003 A	11/1994	Williamson, IV
5,285,381 A	2/1994	Iskarous et al.	5,366,133 A	11/1994	Geiste
5,285,945 A	2/1994	Brinkerhoff et al.	5,366,134 A	11/1994	Green et al.
5,286,253 A	2/1994	Fucci	5,366,479 A	11/1994	McGarry et al.
5,289,963 A	3/1994	McGarry et al.	5,368,015 A	11/1994	Wilk
5,290,271 A	3/1994	Jernberg	5,368,592 A	11/1994	Stern et al.
5,290,310 A	3/1994	Makower et al.	5,369,565 A	11/1994	Chen et al.
5,292,053 A	3/1994	Bilotti et al.	5,370,645 A	12/1994	Klicek et al.
5,293,024 A	3/1994	Sugahara et al.	5,372,124 A	12/1994	Takayama et al.
5,297,714 A	3/1994	Kramer	5,372,596 A	12/1994	Klicek et al.
5,304,204 A	4/1994	Bregen	5,372,602 A	12/1994	Burke
D347,474 S	5/1994	Olson	5,374,277 A	12/1994	Hassler
5,307,976 A	5/1994	Olson et al.	5,375,588 A	12/1994	Yoon

US D914,878 S

5,376,095 A	12/1994	Ortiz	5,443,463 A	8/1995	Stern et al.
5,379,933 A	1/1995	Green et al.	5,444,113 A	8/1995	Sinclair et al.
5,381,649 A	1/1995	Webb	5,445,155 A	8/1995	Sieben
5,381,782 A	1/1995	DeLaRama et al.	5,445,304 A	8/1995	Plyley et al.
5,381,943 A	1/1995	Allen et al.	5,445,604 A	8/1995	Lang
5,382,247 A	1/1995	Cimino et al.	5,445,644 A	8/1995	Pietrafitta et al.
5,383,460 A	1/1995	Jang et al.	5,446,646 A	8/1995	Miyazaki
5,383,874 A	1/1995	Jackson et al.	5,447,265 A	9/1995	Vidal et al.
5,383,880 A	1/1995	Hooven	5,447,417 A	9/1995	Kuhl et al.
5,383,881 A	1/1995	Green et al.	5,447,513 A	9/1995	Davison et al.
5,383,882 A	1/1995	Buess et al.	5,449,355 A	9/1995	Rhum et al.
5,383,888 A	1/1995	Zvenyatsky et al.	5,449,365 A	9/1995	Green et al.
5,383,895 A	1/1995	Holmes et al.	5,449,370 A	9/1995	Vaitekunas
5,388,568 A	2/1995	van der Heide	5,452,836 A	9/1995	Huitema et al.
5,389,098 A	2/1995	Tsuruta et al.	5,452,837 A	9/1995	Williamson, IV et al.
5,389,102 A	2/1995	Green et al.	5,454,378 A	10/1995	Palmer et al.
5,389,104 A	2/1995	Hahnen et al.	5,454,822 A	10/1995	Schob et al.
5,391,180 A	2/1995	Tovey et al.	5,454,827 A	10/1995	Aust et al.
5,392,979 A	2/1995	Green et al.	5,456,401 A	10/1995	Green et al.
5,395,030 A	3/1995	Kuramoto et al.	5,456,917 A	10/1995	Wise et al.
5,395,033 A	3/1995	Byrne et al.	5,458,279 A	10/1995	Plyley
5,395,034 A	3/1995	Allen et al.	5,458,579 A	10/1995	Chodorow et al.
5,395,312 A	3/1995	Desai	5,462,215 A	10/1995	Viola et al.
5,395,384 A	3/1995	Duthoit et al.	5,464,013 A	11/1995	Lemelson
5,397,046 A	3/1995	Savage et al.	5,464,144 A	11/1995	Guy et al.
5,397,324 A	3/1995	Carroll et al.	5,464,300 A	11/1995	Crainich
5,400,267 A	3/1995	Denen et al.	5,465,819 A	11/1995	Weilant et al.
5,403,276 A	4/1995	Schechter et al.	5,465,894 A	11/1995	Clark et al.
5,403,312 A	4/1995	Yates et al.	5,465,895 A	11/1995	Knodel et al.
5,404,106 A	4/1995	Matsuda	5,465,896 A	11/1995	Allen et al.
5,404,870 A	4/1995	Brinkerhoff et al.	5,466,020 A	11/1995	Page et al.
5,404,960 A	4/1995	Wada et al.	5,467,911 A	11/1995	Tsuruta et al.
5,405,072 A	4/1995	Zlock et al.	5,468,253 A	11/1995	Bezwada et al.
5,405,073 A	4/1995	Porter	5,470,006 A	11/1995	Rodak
5,405,344 A	4/1995	Williamson et al.	5,470,007 A	11/1995	Plyley et al.
5,405,360 A	4/1995	Tovey	5,470,008 A	11/1995	Rodak
5,407,293 A	4/1995	Crainich	5,470,009 A	11/1995	Rodak
5,408,409 A	4/1995	Glassman et al.	5,470,010 A	11/1995	Rothfuss et al.
5,409,498 A	4/1995	Braddock et al.	5,471,129 A	11/1995	Mann
5,409,703 A	4/1995	McAnalley et al.	5,472,132 A	12/1995	Savage et al.
D357,981 S	5/1995	Green et al.	5,472,442 A	12/1995	Klicek
5,411,481 A	5/1995	Allen et al.	5,473,204 A	12/1995	Temple
5,411,508 A	5/1995	Bessler et al.	5,474,057 A	12/1995	Makower et al.
5,413,107 A	5/1995	Oakley et al.	5,474,223 A	12/1995	Viola et al.
5,413,267 A	5/1995	Solyntjes et al.	5,474,566 A	12/1995	Alesi et al.
5,413,268 A	5/1995	Green et al.	5,474,570 A	12/1995	Kockerling et al.
5,413,272 A	5/1995	Green et al.	5,476,206 A	12/1995	Green et al.
5,413,573 A	5/1995	Koivukangas	5,476,479 A	12/1995	Green et al.
5,415,334 A	5/1995	Williamson et al.	5,476,481 A	12/1995	Schondorf
5,415,335 A	5/1995	Knodell, Jr.	5,478,003 A	12/1995	Green et al.
5,417,203 A	5/1995	Tovey et al.	5,478,354 A	12/1995	Tovey et al.
5,417,361 A	5/1995	Williamson, IV	5,480,089 A	1/1996	Blewett
5,419,766 A	5/1995	Chang et al.	5,480,409 A	1/1996	Riza
5,421,829 A	6/1995	Olichney et al.	5,482,197 A	1/1996	Green et al.
5,422,567 A	6/1995	Matsunaga	5,483,952 A	1/1996	Aranyi
5,423,471 A	6/1995	Mastri et al.	5,484,095 A	1/1996	Green et al.
5,423,809 A	6/1995	Klicek	5,484,398 A	1/1996	Stoddard
5,423,835 A	6/1995	Green et al.	5,484,451 A	1/1996	Akopov et al.
5,425,355 A	6/1995	Kulick	5,485,947 A	1/1996	Olson et al.
5,425,745 A	6/1995	Green et al.	5,485,952 A	1/1996	Fontayne
5,427,298 A	6/1995	Tegtmeier	5,487,499 A	1/1996	Sorrentino et al.
5,431,322 A	7/1995	Green et al.	5,487,500 A	1/1996	Knodel et al.
5,431,323 A	7/1995	Smith et al.	5,489,058 A	2/1996	Plyley et al.
5,431,654 A	7/1995	Nic	5,489,256 A	2/1996	Adair
5,431,668 A	7/1995	Burbank, III et al.	5,489,290 A	2/1996	Furnish
5,433,721 A	7/1995	Hooven et al.	5,490,819 A	2/1996	Nicholas et al.
5,437,681 A	8/1995	Meade et al.	5,492,671 A	2/1996	Krafft
5,438,302 A	8/1995	Goble	5,496,312 A	3/1996	Klicek
5,438,997 A	8/1995	Sieben et al.	5,496,317 A	3/1996	Goble et al.
5,439,155 A	8/1995	Viola	5,497,933 A	3/1996	DeFonzo et al.
5,439,156 A	8/1995	Grant et al.	5,498,164 A	3/1996	Ward et al.
5,439,479 A	8/1995	Shichman et al.	5,498,838 A	3/1996	Furman
5,441,191 A	8/1995	Linden	5,501,654 A	3/1996	Failla et al.
5,441,193 A	8/1995	Gravener	5,503,320 A	4/1996	Webster et al.
5,441,483 A	8/1995	Avitall	5,503,635 A	4/1996	Sauer et al.
5,441,494 A	8/1995	Ortiz	5,503,638 A	4/1996	Cooper et al.
5,441,499 A	8/1995	Fritzschn	5,505,363 A	4/1996	Green et al.
5,443,197 A	8/1995	Malis et al.	5,507,425 A	4/1996	Ziglioli
5,443,198 A	8/1995	Viola et al.	5,507,426 A	4/1996	Young et al.

US D914,878 S

5,509,596 A	4/1996	Green et al.	5,575,803 A	11/1996	Cooper et al.
5,509,916 A	4/1996	Taylor	5,575,805 A	11/1996	Li
5,511,564 A	4/1996	Wilk	5,577,654 A	11/1996	Bishop
5,514,129 A	5/1996	Smith	5,578,052 A	11/1996	Koros et al.
5,514,149 A	5/1996	Green et al.	5,579,978 A	12/1996	Green et al.
5,514,157 A	5/1996	Nicholas et al.	5,580,067 A	12/1996	Hamblin et al.
5,518,163 A	5/1996	Hooven	5,582,611 A	12/1996	Tsuruta et al.
5,518,164 A	5/1996	Hooven	5,582,617 A	12/1996	Klieman et al.
5,520,609 A	5/1996	Moll et al.	5,582,907 A	12/1996	Pall
5,520,634 A	5/1996	Fox et al.	5,583,114 A	12/1996	Barrows et al.
5,520,678 A	5/1996	Heckele et al.	5,584,425 A	12/1996	Savage et al.
5,520,700 A	5/1996	Beyar et al.	5,586,711 A	12/1996	Plyley et al.
5,522,817 A	6/1996	Sander et al.	5,588,579 A	12/1996	Schnut et al.
5,522,831 A	6/1996	Sleister et al.	5,588,580 A	12/1996	Paul et al.
5,527,264 A	6/1996	Moll et al.	5,588,581 A	12/1996	Conlon et al.
5,527,320 A	6/1996	Carruthers et al.	5,591,170 A	1/1997	Spievack et al.
5,529,235 A	6/1996	Boiarski et al.	5,591,187 A	1/1997	Dekel
D372,086 S	7/1996	Grasso et al.	5,597,107 A	1/1997	Knodel et al.
5,531,305 A	7/1996	Roberts et al.	5,599,151 A	2/1997	Daum et al.
5,531,744 A	7/1996	Nardella et al.	5,599,279 A	2/1997	Slotman et al.
5,531,856 A	7/1996	Moll et al.	5,599,344 A	2/1997	Paterson
5,533,521 A	7/1996	Granger	5,599,350 A	2/1997	Schulze et al.
5,533,581 A	7/1996	Barth et al.	5,599,852 A	2/1997	Scopelianos et al.
5,533,661 A	7/1996	Main et al.	5,601,224 A	2/1997	Bishop et al.
5,535,934 A	7/1996	Boiarski et al.	5,601,573 A	2/1997	Fogelberg et al.
5,535,935 A	7/1996	Vidal et al.	5,601,604 A	2/1997	Vincent
5,535,937 A	7/1996	Boiarski et al.	5,602,449 A	2/1997	Krause et al.
5,540,375 A	7/1996	Bolanos et al.	5,603,443 A	2/1997	Clark et al.
5,540,705 A	7/1996	Meade et al.	5,605,272 A	2/1997	Witt et al.
5,541,376 A	7/1996	Ladtkow et al.	5,605,273 A	2/1997	Hamblin et al.
5,541,489 A	7/1996	Dunstan	5,607,094 A	3/1997	Clark et al.
5,542,594 A	8/1996	McKean et al.	5,607,095 A	3/1997	Smith et al.
5,542,945 A	8/1996	Fritzsich	5,607,433 A	3/1997	Polla et al.
5,542,949 A	8/1996	Yoon	5,607,450 A	3/1997	Zvenyatsky et al.
5,543,119 A	8/1996	Sutter et al.	5,607,474 A	3/1997	Athanasidou et al.
5,543,695 A	8/1996	Culp et al.	5,609,285 A	3/1997	Grant et al.
5,544,802 A	8/1996	Crainich	5,609,601 A	3/1997	Kolesa et al.
5,547,117 A	8/1996	Hamblin et al.	5,611,709 A	3/1997	McAnulty
5,549,583 A	8/1996	Sanford et al.	5,613,499 A	3/1997	Palmer et al.
5,549,621 A	8/1996	Bessler et al.	5,613,937 A	3/1997	Garrison et al.
5,549,627 A	8/1996	Kieturakis	5,613,966 A	3/1997	Makower et al.
5,549,628 A	8/1996	Cooper et al.	5,614,887 A	3/1997	Buchbinder
5,549,637 A	8/1996	Crainich	5,615,820 A	4/1997	Viola
5,551,622 A	9/1996	Yoon	5,618,294 A	4/1997	Aust et al.
5,553,624 A	9/1996	Francese et al.	5,618,303 A	4/1997	Marlow et al.
5,553,675 A	9/1996	Pitzen et al.	5,618,307 A	4/1997	Donlon et al.
5,553,765 A	9/1996	Knodel et al.	5,619,992 A	4/1997	Guthrie et al.
5,554,148 A	9/1996	Aebischer et al.	5,620,289 A	4/1997	Curry
5,554,169 A	9/1996	Green et al.	5,620,326 A	4/1997	Younker
5,556,020 A	9/1996	Hou	5,620,452 A	4/1997	Yoon
5,556,416 A	9/1996	Clark et al.	5,624,398 A	4/1997	Smith et al.
5,558,533 A	9/1996	Hashizawa et al.	5,624,452 A	4/1997	Yates
5,558,665 A	9/1996	Kieturakis	5,626,587 A	5/1997	Bishop et al.
5,558,671 A	9/1996	Yates	5,626,595 A	5/1997	Sklar et al.
5,560,530 A	10/1996	Bolanos et al.	5,628,446 A	5/1997	Geiste et al.
5,560,532 A	10/1996	DeFonzo et al.	5,628,743 A	5/1997	Cimino
5,561,881 A	10/1996	Klinger et al.	5,628,745 A	5/1997	Bek
5,562,239 A	10/1996	Boiarski et al.	5,630,539 A	5/1997	Plyley et al.
5,562,241 A	10/1996	Knodel et al.	5,630,540 A	5/1997	Blewett
5,562,682 A	10/1996	Oberlin et al.	5,630,541 A	5/1997	Williamson, IV et al.
5,562,690 A	10/1996	Green et al.	5,630,782 A	5/1997	Adair
5,562,701 A	10/1996	Huitema et al.	5,631,973 A	5/1997	Green
5,562,702 A	10/1996	Huitema et al.	5,632,432 A	5/1997	Schulze et al.
5,563,481 A	10/1996	Krause	5,632,433 A	5/1997	Grant et al.
5,564,615 A	10/1996	Bishop et al.	5,633,374 A	5/1997	Humphrey et al.
5,569,161 A	10/1996	Ebling et al.	5,634,584 A	6/1997	Okorochoa et al.
5,569,270 A	10/1996	Weng	5,636,779 A	6/1997	Palmer
5,569,284 A	10/1996	Young et al.	5,636,780 A	6/1997	Green et al.
5,571,090 A	11/1996	Sherts	5,638,582 A	6/1997	Klatt et al.
5,571,100 A	11/1996	Goble et al.	5,639,008 A	6/1997	Gallagher et al.
5,571,116 A	11/1996	Bolanos et al.	D381,077 S	7/1997	Hunt
5,571,285 A	11/1996	Chow et al.	5,643,291 A	7/1997	Pier et al.
5,571,488 A	11/1996	Beerstecher et al.	5,643,293 A	7/1997	Kogasaka et al.
5,573,169 A	11/1996	Green et al.	5,643,294 A	7/1997	Tovey et al.
5,573,543 A	11/1996	Akopov et al.	5,643,319 A	7/1997	Green et al.
5,574,431 A	11/1996	McKeown et al.	5,645,209 A	7/1997	Green et al.
5,575,054 A	11/1996	Klinzing et al.	5,647,526 A	7/1997	Green et al.
5,575,789 A	11/1996	Bell et al.	5,647,869 A	7/1997	Goble et al.
5,575,799 A	11/1996	Bolanos et al.	5,649,937 A	7/1997	Bitto et al.

US D914,878 S

5,649,956 A	7/1997	Jensen et al.	5,713,895 A	2/1998	Lontine et al.
5,651,491 A	7/1997	Heaton et al.	5,713,896 A	2/1998	Nardella
5,651,762 A	7/1997	Bridges	5,713,920 A	2/1998	Bezwada et al.
5,651,821 A	7/1997	Uchida	5,715,604 A	2/1998	Lanzoni
5,653,373 A	8/1997	Green et al.	5,715,987 A	2/1998	Kelley et al.
5,653,374 A	8/1997	Young et al.	5,715,988 A	2/1998	Palmer
5,653,677 A	8/1997	Okada et al.	5,716,366 A	2/1998	Yates
5,653,721 A	8/1997	Knodel et al.	5,718,359 A	2/1998	Palmer et al.
5,653,748 A	8/1997	Strecker	5,718,360 A	2/1998	Green et al.
5,655,698 A	8/1997	Yoon	5,718,548 A	2/1998	Cotellessa
5,657,417 A	8/1997	Di Troia	5,718,714 A	2/1998	Livneh
5,657,429 A	8/1997	Wang et al.	5,720,744 A	2/1998	Eggleston et al.
5,657,921 A	8/1997	Young et al.	D393,067 S	3/1998	Geary et al.
5,658,238 A	8/1997	Suzuki et al.	5,724,025 A	3/1998	Tavori
5,658,281 A	8/1997	Heard	5,725,536 A	3/1998	Oberlin et al.
5,658,298 A	8/1997	Vincent et al.	5,725,554 A	3/1998	Simon et al.
5,658,300 A	8/1997	Bito et al.	5,728,110 A	3/1998	Vidal et al.
5,658,307 A	8/1997	Exconde	5,728,113 A	3/1998	Sherts
5,662,258 A	9/1997	Knodel et al.	5,728,121 A	3/1998	Bimbo et al.
5,662,260 A	9/1997	Yoon	5,730,758 A	3/1998	Allgeyer
5,662,662 A	9/1997	Bishop et al.	5,732,821 A	3/1998	Stone et al.
5,662,667 A	9/1997	Knodel	5,732,871 A	3/1998	Clark et al.
5,665,085 A	9/1997	Nardella	5,732,872 A	3/1998	Bolduc et al.
5,667,517 A	9/1997	Hooven	5,733,308 A	3/1998	Daugherty et al.
5,667,526 A	9/1997	Levin	5,735,445 A	4/1998	Vidal et al.
5,667,527 A	9/1997	Cook	5,735,848 A	4/1998	Yates et al.
5,667,864 A	9/1997	Landoll	5,735,874 A	4/1998	Measamer et al.
5,669,544 A	9/1997	Schulze et al.	5,738,474 A	4/1998	Blewett
5,669,904 A	9/1997	Platt, Jr. et al.	5,738,629 A	4/1998	Moll et al.
5,669,907 A	9/1997	Platt, Jr. et al.	5,738,648 A	4/1998	Lands et al.
5,669,918 A	9/1997	Balazs et al.	5,741,271 A	4/1998	Nakao et al.
5,672,945 A	9/1997	Krause	5,743,456 A	4/1998	Jones et al.
5,673,840 A	10/1997	Schulze et al.	5,747,953 A	5/1998	Philipp
5,673,841 A	10/1997	Schulze et al.	5,749,889 A	5/1998	Bacich et al.
5,673,842 A	10/1997	Bittner et al.	5,749,893 A	5/1998	Vidal et al.
5,674,184 A	10/1997	Hassler, Jr.	5,749,896 A	5/1998	Cook
5,674,286 A	10/1997	D'Alessio et al.	5,749,968 A	5/1998	Melanson et al.
5,678,748 A	10/1997	Plyley et al.	5,752,644 A	5/1998	Bolanos et al.
5,680,981 A	10/1997	Mililli et al.	5,752,965 A	5/1998	Francis et al.
5,680,982 A	10/1997	Schulze et al.	5,752,970 A	5/1998	Yoon
5,680,983 A	10/1997	Plyley et al.	5,752,973 A	5/1998	Kieturakis
5,681,341 A	10/1997	Lunsford et al.	5,755,717 A	5/1998	Yates et al.
5,683,349 A	11/1997	Makower et al.	5,758,814 A	6/1998	Gallagher et al.
5,685,474 A	11/1997	Seeber	5,762,255 A	6/1998	Chrisman et al.
5,686,090 A	11/1997	Schilder et al.	5,762,256 A	6/1998	Mastri et al.
5,688,270 A	11/1997	Yates et al.	5,765,565 A	6/1998	Adair
5,690,269 A	11/1997	Bolanos et al.	5,766,188 A	6/1998	Igaki
5,690,675 A	11/1997	Sawyer et al.	5,766,205 A	6/1998	Zvenyatsky et al.
5,692,668 A	12/1997	Schulze et al.	5,769,303 A	6/1998	Knodel et al.
5,693,020 A	12/1997	Rauh	5,769,748 A	6/1998	Eyerly et al.
5,693,042 A	12/1997	Boiarski et al.	5,769,791 A	6/1998	Benaron et al.
5,693,051 A	12/1997	Schulze et al.	5,769,892 A	6/1998	Kingwell
5,695,494 A	12/1997	Becker	5,772,379 A	6/1998	Evensen
5,695,502 A	12/1997	Pier et al.	5,772,578 A	6/1998	Heimberger et al.
5,695,504 A	12/1997	Gifford, III et al.	5,772,659 A	6/1998	Becker et al.
5,695,524 A	12/1997	Kelley et al.	5,773,991 A	6/1998	Chen
5,697,542 A	12/1997	Knodel et al.	5,776,130 A	7/1998	Buysse et al.
5,697,543 A	12/1997	Burdorff	5,778,939 A	7/1998	Hok-Yin
5,697,909 A	12/1997	Eggers et al.	5,779,130 A	7/1998	Alesi et al.
5,697,943 A	12/1997	Sauer et al.	5,779,131 A	7/1998	Knodel et al.
5,700,270 A	12/1997	Peyser et al.	5,779,132 A	7/1998	Knodel et al.
5,700,276 A	12/1997	Benecke	5,782,396 A	7/1998	Mastri et al.
5,702,387 A	12/1997	Arts et al.	5,782,397 A	7/1998	Koukline
5,702,408 A	12/1997	Wales et al.	5,782,748 A	7/1998	Palmer et al.
5,702,409 A	12/1997	Rayburn et al.	5,782,749 A	7/1998	Riza
5,704,087 A	1/1998	Strub	5,782,859 A	7/1998	Nicholas et al.
5,704,534 A	1/1998	Huitema et al.	5,784,934 A	7/1998	Izumisawa
5,706,997 A	1/1998	Green et al.	5,785,232 A	7/1998	Vidal et al.
5,706,998 A	1/1998	Plyley et al.	5,785,647 A	7/1998	Tompkins et al.
5,707,392 A	1/1998	Kortenbach	5,787,897 A	8/1998	Kieturakis
5,709,334 A	1/1998	Sorrentino et al.	5,791,231 A	8/1998	Cohn et al.
5,709,335 A	1/1998	Heck	5,792,135 A	8/1998	Madhani et al.
5,709,680 A	1/1998	Yates et al.	5,792,162 A	8/1998	Jolly et al.
5,709,706 A	1/1998	Kienzle et al.	5,792,165 A	8/1998	Klieman et al.
5,711,472 A	1/1998	Bryan	5,792,573 A	8/1998	Pitzen et al.
5,711,960 A	1/1998	Shikinami	5,794,834 A	8/1998	Hamblin et al.
5,712,460 A	1/1998	Carr et al.	5,796,188 A	8/1998	Bays
5,713,128 A	2/1998	Schrenk et al.	5,797,536 A	8/1998	Smith et al.
5,713,505 A	2/1998	Huitema	5,797,537 A	8/1998	Oberlin et al.

US D914,878 S

5,797,538 A	8/1998	Heaton et al.	5,891,094 A	4/1999	Masterson et al.
5,797,637 A	8/1998	Ervin	5,891,160 A	4/1999	Williamson, IV et al.
5,797,900 A	8/1998	Madhani et al.	5,891,558 A	4/1999	Bell et al.
5,797,906 A	8/1998	Rhum et al.	5,893,506 A	4/1999	Powell
5,797,927 A	8/1998	Yoon	5,893,835 A	4/1999	Witt et al.
5,797,941 A	8/1998	Schulze et al.	5,893,878 A	4/1999	Pierce
5,797,959 A	8/1998	Castro et al.	5,894,979 A	4/1999	Powell
5,799,857 A	9/1998	Robertson et al.	5,897,552 A	4/1999	Edwards et al.
5,800,379 A	9/1998	Edwards	5,897,562 A	4/1999	Bolanos et al.
5,800,423 A	9/1998	Jensen	5,899,824 A	5/1999	Kurtz et al.
5,804,726 A	9/1998	Geib et al.	5,899,914 A	5/1999	Zirps et al.
5,804,936 A	9/1998	Brodsky et al.	5,901,895 A	5/1999	Heaton et al.
5,806,676 A	9/1998	Wasgien	5,902,312 A	5/1999	Frater et al.
5,807,376 A	9/1998	Viola et al.	5,903,117 A	5/1999	Gregory
5,807,378 A	9/1998	Jensen et al.	5,904,647 A	5/1999	Ouchi
5,807,393 A	9/1998	Williamson, IV et al.	5,904,693 A	5/1999	Dicesare et al.
5,809,441 A	9/1998	McKee	5,904,702 A	5/1999	Ek et al.
5,810,721 A	9/1998	Mueller et al.	5,906,577 A	5/1999	Beane et al.
5,810,811 A	9/1998	Yates et al.	5,906,625 A	5/1999	Bito et al.
5,810,846 A	9/1998	Virnich et al.	5,907,211 A	5/1999	Hall et al.
5,810,855 A	9/1998	Rayburn et al.	5,908,402 A	6/1999	Blythe
5,812,188 A	9/1998	Adair	5,908,427 A	6/1999	McKean et al.
5,813,813 A	9/1998	Daum et al.	5,909,062 A	6/1999	Krietzman
5,814,055 A	9/1998	Knodel et al.	5,911,353 A	6/1999	Bolanos et al.
5,814,057 A	9/1998	Oi et al.	5,915,616 A	6/1999	Viola et al.
5,816,471 A	10/1998	Plyley et al.	5,916,225 A	6/1999	Kugel
5,817,084 A	10/1998	Jensen	5,918,791 A	7/1999	Sorrentino et al.
5,817,091 A	10/1998	Nardella et al.	5,919,198 A	7/1999	Graves, Jr. et al.
5,817,093 A	10/1998	Williamson, IV et al.	5,921,956 A	7/1999	Grinberg et al.
5,817,109 A	10/1998	McGarry et al.	5,924,864 A	7/1999	Loge et al.
5,817,119 A	10/1998	Klieman et al.	5,928,137 A	7/1999	Green
5,820,009 A	10/1998	Melling et al.	5,928,256 A	7/1999	Riza
5,823,066 A	10/1998	Huitema et al.	5,931,847 A	8/1999	Bittner et al.
5,824,333 A	10/1998	Scopelianos et al.	5,931,853 A	8/1999	McEwen et al.
5,826,776 A	10/1998	Schulze et al.	5,937,951 A	8/1999	Izuchukwu et al.
5,827,271 A	10/1998	Buysse et al.	5,938,667 A	8/1999	Peysen et al.
5,827,298 A	10/1998	Hart et al.	5,941,442 A	8/1999	Geiste et al.
5,827,323 A	10/1998	Klieman et al.	5,941,890 A	8/1999	Voegele et al.
5,829,662 A	11/1998	Allen et al.	5,944,172 A	8/1999	Hannula
5,830,598 A	11/1998	Patterson	5,944,715 A	8/1999	Goble et al.
5,833,690 A	11/1998	Yates et al.	5,946,978 A	9/1999	Yamashita
5,833,695 A	11/1998	Yoon	5,947,984 A	9/1999	Whipple
5,833,696 A	11/1998	Whitfield et al.	5,947,996 A	9/1999	Logeman
5,836,503 A	11/1998	Ehrenfels et al.	5,948,030 A	9/1999	Miller et al.
5,836,960 A	11/1998	Kolesa et al.	5,948,429 A	9/1999	Bell et al.
5,839,369 A	11/1998	Chatterjee et al.	5,951,301 A	9/1999	Younker
5,839,639 A	11/1998	Sauer et al.	5,951,516 A	9/1999	Bunyan
5,841,284 A	11/1998	Takahashi	5,951,552 A	9/1999	Long et al.
5,843,021 A	12/1998	Edwards et al.	5,951,574 A	9/1999	Stefanchik et al.
5,843,096 A	12/1998	Igaki et al.	5,951,575 A	9/1999	Bolduc et al.
5,843,097 A	12/1998	Mayenberger et al.	5,951,581 A	9/1999	Saadat et al.
5,843,122 A	12/1998	Riza	5,954,259 A	9/1999	Viola et al.
5,843,132 A	12/1998	Ilvento	5,957,831 A	9/1999	Adair
5,843,169 A	12/1998	Taheri	5,964,394 A	10/1999	Robertson
5,846,254 A	12/1998	Schulze et al.	5,964,774 A	10/1999	McKean et al.
5,847,566 A	12/1998	Marritt et al.	5,966,126 A	10/1999	Szabo
5,849,011 A	12/1998	Jones et al.	5,971,916 A	10/1999	Koren
5,849,020 A	12/1998	Long et al.	5,973,221 A	10/1999	Collyer et al.
5,849,023 A	12/1998	Mericle	D416,089 S	11/1999	Barton et al.
5,851,179 A	12/1998	Ritson et al.	5,976,122 A	11/1999	Madhani et al.
5,851,212 A	12/1998	Zirps et al.	5,977,746 A	11/1999	Hershberger et al.
5,853,366 A	12/1998	Dowlatshahi	5,980,248 A	11/1999	Kusakabe et al.
5,855,311 A	1/1999	Hamblin et al.	5,984,949 A	11/1999	Levin
5,855,583 A	1/1999	Wang et al.	5,988,479 A	11/1999	Palmer
5,860,581 A	1/1999	Robertson et al.	5,990,379 A	11/1999	Gregory
5,860,975 A	1/1999	Goble et al.	5,993,466 A	11/1999	Yoon
5,865,361 A	2/1999	Milliman et al.	5,997,528 A	12/1999	Bisch et al.
5,865,638 A	2/1999	Trafton	5,997,552 A	12/1999	Person et al.
5,868,361 A	2/1999	Rinderer	6,001,108 A	12/1999	Wang et al.
5,868,760 A	2/1999	McGuckin, Jr.	6,003,517 A	12/1999	Sheffield et al.
5,868,790 A	2/1999	Vincent et al.	6,004,319 A	12/1999	Goble et al.
5,871,135 A	2/1999	Williamson, IV et al.	6,004,335 A	12/1999	Vaitekunas et al.
5,873,885 A	2/1999	Weidenbenner	6,007,521 A	12/1999	Bidwell et al.
5,876,401 A	3/1999	Schulze et al.	6,010,054 A	1/2000	Johnson et al.
5,878,193 A	3/1999	Wang et al.	6,010,513 A	1/2000	Tormala et al.
5,878,607 A	3/1999	Nunes et al.	6,010,520 A	1/2000	Pattison
5,878,937 A	3/1999	Green et al.	6,012,494 A	1/2000	Balazs
5,878,938 A	3/1999	Bittner et al.	6,013,076 A	1/2000	Goble et al.
5,881,777 A	3/1999	Bassi et al.	6,015,406 A	1/2000	Goble et al.

US D914,878 S

Page 10

6,015,417 A	1/2000	Reynolds, Jr.	6,099,551 A	8/2000	Gabbay
6,017,322 A	1/2000	Snoke et al.	6,102,271 A	8/2000	Longo et al.
6,017,354 A	1/2000	Culp et al.	6,102,926 A	8/2000	Tartaglia et al.
6,017,356 A	1/2000	Frederick et al.	6,104,162 A	8/2000	Sainsbury et al.
6,018,227 A	1/2000	Kumar et al.	6,104,304 A	8/2000	Clark et al.
6,019,745 A	2/2000	Gray	6,106,511 A	8/2000	Jensen
6,022,352 A	2/2000	Vandewalle	6,109,500 A	8/2000	Alli et al.
6,023,641 A	2/2000	Thompson	6,110,187 A	8/2000	Donlon
6,024,708 A	2/2000	Bales et al.	6,113,618 A	9/2000	Nic
6,024,741 A	2/2000	Williamson, IV et al.	6,117,148 A	9/2000	Ravo et al.
6,024,748 A	2/2000	Manzo et al.	6,117,158 A	9/2000	Measamer et al.
6,024,750 A	2/2000	Mastri et al.	6,119,913 A	9/2000	Adams et al.
6,024,764 A	2/2000	Schroepfel	6,120,433 A	9/2000	Mizuno et al.
6,027,501 A	2/2000	Goble et al.	6,120,462 A	9/2000	Hibner et al.
6,030,384 A	2/2000	Nezhat	6,123,241 A	9/2000	Walter et al.
6,032,849 A	3/2000	Mastri et al.	6,123,701 A	9/2000	Nezhat
6,033,105 A	3/2000	Barker et al.	H1904 H	10/2000	Yates et al.
6,033,378 A	3/2000	Lundquist et al.	6,126,058 A	10/2000	Adams et al.
6,033,399 A	3/2000	Gines	6,126,359 A	10/2000	Dittrich et al.
6,033,427 A	3/2000	Lee	6,126,670 A	10/2000	Walker et al.
6,036,641 A	3/2000	Taylor et al.	6,131,789 A	10/2000	Schulze et al.
6,036,667 A	3/2000	Manna et al.	6,131,790 A	10/2000	Piraka
6,037,724 A	3/2000	Buss et al.	6,132,368 A	10/2000	Cooper
6,037,927 A	3/2000	Rosenberg	6,134,962 A	10/2000	Sugitani
6,039,733 A	3/2000	Buyse et al.	6,139,546 A	10/2000	Koenig et al.
6,039,734 A	3/2000	Goble	6,142,149 A	11/2000	Steen
6,042,601 A	3/2000	Smith	6,142,933 A	11/2000	Longo et al.
6,042,607 A	3/2000	Williamson, IV et al.	6,147,135 A	11/2000	Yuan et al.
6,043,626 A	3/2000	Snyder et al.	6,149,660 A	11/2000	Laufer et al.
6,045,560 A	4/2000	McKean et al.	6,151,323 A	11/2000	O'Connell et al.
6,047,861 A	4/2000	Vidal et al.	6,152,935 A	11/2000	Kammerer et al.
6,049,145 A	4/2000	Austin et al.	6,155,473 A	12/2000	Tompkins et al.
6,050,172 A	4/2000	Corves et al.	6,156,056 A	12/2000	Kearns et al.
6,050,472 A	4/2000	Shibata	6,157,169 A	12/2000	Lee
6,050,989 A	4/2000	Fox et al.	6,159,146 A	12/2000	El Gazayerli
6,050,990 A	4/2000	Tankovich et al.	6,159,200 A	12/2000	Verdura et al.
6,050,996 A	4/2000	Schmaltz et al.	6,159,224 A	12/2000	Yoon
6,053,390 A	4/2000	Green et al.	6,162,208 A	12/2000	Hipps
6,053,899 A	4/2000	Slanda et al.	6,162,220 A	12/2000	Nezhat
6,053,922 A	4/2000	Krause et al.	6,162,537 A	12/2000	Martin et al.
6,054,142 A	4/2000	Li et al.	6,165,175 A	12/2000	Wampler et al.
6,055,062 A	4/2000	Dina et al.	6,165,184 A	12/2000	Verdura et al.
RE36,720 E	5/2000	Green et al.	6,165,188 A	12/2000	Saadat et al.
6,056,735 A	5/2000	Okada et al.	6,167,185 A	12/2000	Smiley et al.
6,056,746 A	5/2000	Goble et al.	6,168,605 B1	1/2001	Measamer et al.
6,059,806 A	5/2000	Hoegerle	6,171,305 B1	1/2001	Sherman
6,062,360 A	5/2000	Shields	6,171,316 B1	1/2001	Kovac et al.
6,063,020 A	5/2000	Jones et al.	6,171,330 B1	1/2001	Benchetrit
6,063,025 A	5/2000	Bridges et al.	6,173,074 B1	1/2001	Russo
6,063,050 A	5/2000	Manna et al.	6,174,308 B1	1/2001	Goble et al.
6,063,095 A	5/2000	Wang et al.	6,174,309 B1	1/2001	Wrublewski et al.
6,063,097 A	5/2000	Oi et al.	6,174,318 B1	1/2001	Bates et al.
6,063,098 A	5/2000	Houser et al.	6,175,290 B1	1/2001	Forsythe et al.
6,065,679 A	5/2000	Levie et al.	6,179,195 B1	1/2001	Adams et al.
6,065,919 A	5/2000	Peck	6,179,776 B1	1/2001	Adams et al.
6,066,132 A	5/2000	Chen et al.	6,181,105 B1	1/2001	Cutolo et al.
6,066,151 A	5/2000	Miyawaki et al.	6,182,673 B1	2/2001	Kindermann et al.
6,068,627 A	5/2000	Orszulak et al.	6,185,356 B1	2/2001	Parker et al.
6,071,233 A	6/2000	Ishikawa et al.	6,186,142 B1	2/2001	Schmidt et al.
6,072,299 A	6/2000	Kurle et al.	6,186,957 B1	2/2001	Milam
6,074,386 A	6/2000	Goble et al.	6,187,003 B1	2/2001	Buyse et al.
6,074,401 A	6/2000	Gardiner et al.	6,190,386 B1	2/2001	Rydell
6,075,441 A	6/2000	Maloney	6,193,129 B1	2/2001	Bittner et al.
6,077,280 A	6/2000	Fossum	6,197,042 B1	3/2001	Ginn et al.
6,077,286 A	6/2000	Cuschieri et al.	6,200,311 B1	3/2001	Danek et al.
6,077,290 A	6/2000	Marini	6,200,330 B1	3/2001	Benderev et al.
6,079,606 A	6/2000	Milliman et al.	6,202,914 B1	3/2001	Geiste et al.
6,080,181 A	6/2000	Jensen et al.	6,206,894 B1	3/2001	Thompson et al.
6,082,577 A	7/2000	Coates et al.	6,206,897 B1	3/2001	Jamiolkowski et al.
6,083,191 A	7/2000	Rose	6,206,903 B1	3/2001	Ramans
6,083,223 A	7/2000	Baker	6,206,904 B1	3/2001	Ouchi
6,083,234 A	7/2000	Nicholas et al.	6,209,414 B1	4/2001	Uneme
6,083,242 A	7/2000	Cook	6,210,403 B1	4/2001	Klicek
6,086,544 A	7/2000	Hibner et al.	6,211,626 B1	4/2001	Lys et al.
6,086,600 A	7/2000	Kortenbach	6,213,999 B1	4/2001	Platt, Jr. et al.
6,090,106 A	7/2000	Goble et al.	6,214,028 B1	4/2001	Yoon et al.
6,093,186 A	7/2000	Goble	6,220,368 B1	4/2001	Ark et al.
D429,252 S	8/2000	Haitani et al.	6,221,007 B1	4/2001	Green
6,099,537 A	8/2000	Sugai et al.	6,221,023 B1	4/2001	Matsuba et al.

US D914,878 S

Page 11

6,223,100 B1	4/2001	Green	6,352,532 B1	3/2002	Kramer et al.
6,223,835 B1	5/2001	Habedank et al.	6,355,699 B1	3/2002	Vyakarnam et al.
6,224,617 B1	5/2001	Saadat et al.	6,356,072 B1	3/2002	Chass
6,228,080 B1	5/2001	Gines	6,358,224 B1	3/2002	Tims et al.
6,228,081 B1	5/2001	Goble	6,358,263 B2	3/2002	Mark et al.
6,228,083 B1	5/2001	Lands et al.	6,358,459 B1	3/2002	Ziegler et al.
6,228,084 B1	5/2001	Kirwan, Jr.	6,364,877 B1	4/2002	Goble et al.
6,228,089 B1	5/2001	Wahrburg	6,364,888 B1	4/2002	Niemeyer et al.
6,228,098 B1	5/2001	Kayan et al.	6,366,441 B1	4/2002	Ozawa et al.
6,231,565 B1	5/2001	Tovey et al.	6,370,981 B2	4/2002	Watarai
6,234,178 B1	5/2001	Goble et al.	6,371,114 B1	4/2002	Schmidt et al.
6,237,604 B1	5/2001	Burnside et al.	6,373,152 B1	4/2002	Wang et al.
6,238,384 B1	5/2001	Peer	6,377,011 B1	4/2002	Ben-Ur
6,241,139 B1	6/2001	Milliman et al.	6,383,201 B1	5/2002	Dong
6,241,140 B1	6/2001	Adams et al.	6,387,092 B1	5/2002	Burnside et al.
6,241,723 B1	6/2001	Heim et al.	6,387,113 B1	5/2002	Hawkins et al.
6,245,084 B1	6/2001	Mark et al.	6,387,114 B2	5/2002	Adams
6,248,116 B1	6/2001	Chevillon et al.	6,391,038 B2	5/2002	Vargas et al.
6,248,117 B1	6/2001	Blatter	6,392,854 B1	5/2002	O'Gorman
6,249,076 B1	6/2001	Madden et al.	6,394,998 B1	5/2002	Wallace et al.
6,249,105 B1	6/2001	Andrews et al.	6,398,779 B1	6/2002	Buysse et al.
6,250,532 B1	6/2001	Green et al.	6,398,781 B1	6/2002	Goble et al.
6,251,485 B1	6/2001	Harris et al.	6,398,797 B2	6/2002	Bombard et al.
D445,745 S	7/2001	Norman	6,402,766 B2	6/2002	Bowman et al.
6,254,534 B1	7/2001	Butler et al.	6,406,440 B1	6/2002	Stefanchik
6,254,619 B1	7/2001	Garabet et al.	6,406,472 B1	6/2002	Jensen
6,254,642 B1	7/2001	Taylor	6,409,724 B1	6/2002	Penny et al.
6,258,107 B1	7/2001	Balazs et al.	H2037 H	7/2002	Yates et al.
6,261,246 B1	7/2001	Pantages et al.	6,412,639 B1	7/2002	Hickey
6,261,286 B1	7/2001	Goble et al.	6,413,274 B1	7/2002	Pedros
6,261,679 B1	7/2001	Chen et al.	6,415,542 B1	7/2002	Bates et al.
6,264,086 B1	7/2001	McGuckin, Jr.	6,416,486 B1	7/2002	Wampler
6,264,087 B1	7/2001	Whitman	6,416,509 B1	7/2002	Goble et al.
6,264,617 B1	7/2001	Bales et al.	6,419,695 B1	7/2002	Gabbay
6,269,997 B1	8/2001	Balazs et al.	6,423,079 B1	7/2002	Blake, III
6,270,508 B1	8/2001	Klieman et al.	6,424,885 B1	7/2002	Niemeyer et al.
6,270,916 B1	8/2001	Sink et al.	RE37,814 E	8/2002	Allgeyer
6,273,252 B1	8/2001	Mitchell	6,428,070 B1	8/2002	Takanashi et al.
6,273,876 B1	8/2001	Klima et al.	6,428,487 B1	8/2002	Burdorff et al.
6,273,897 B1	8/2001	Dalessandro et al.	6,429,611 B1	8/2002	Li
6,277,114 B1	8/2001	Bullivant et al.	6,430,298 B1	8/2002	Kettl et al.
6,280,407 B1	8/2001	Manna et al.	6,432,065 B1	8/2002	Burdorff et al.
6,283,981 B1	9/2001	Beaupre	6,436,097 B1	8/2002	Nardella
6,293,927 B1	9/2001	McGuckin, Jr.	6,436,107 B1	8/2002	Wang et al.
6,293,942 B1	9/2001	Goble et al.	6,436,110 B2	8/2002	Bowman et al.
6,296,640 B1	10/2001	Wampler et al.	6,436,115 B1	8/2002	Beaupre
6,302,311 B1	10/2001	Adams et al.	6,436,122 B1	8/2002	Frank et al.
6,302,743 B1	10/2001	Chiu et al.	6,439,439 B1	8/2002	Rickard et al.
6,305,891 B1	10/2001	Burlingame	6,439,446 B1	8/2002	Perry et al.
6,306,134 B1	10/2001	Goble et al.	6,440,146 B2	8/2002	Nicholas et al.
6,306,149 B1	10/2001	Meade	6,441,577 B2	8/2002	Blumenkranz et al.
6,306,424 B1	10/2001	Vyakarnam et al.	D462,758 S	9/2002	Epstein et al.
6,309,397 B1	10/2001	Julian et al.	6,443,973 B1	9/2002	Whitman
6,309,400 B2	10/2001	Beaupre	6,445,530 B1	9/2002	Baker
6,309,403 B1	10/2001	Minor et al.	6,447,518 B1	9/2002	Krause et al.
6,312,435 B1	11/2001	Wallace et al.	6,447,523 B1	9/2002	Middleman et al.
6,315,184 B1	11/2001	Whitman	6,447,799 B1	9/2002	Ullman
6,319,510 B1	11/2001	Yates	6,447,864 B2	9/2002	Johnson et al.
6,320,123 B1	11/2001	Reimers	6,450,391 B1	9/2002	Kayan et al.
6,322,494 B1	11/2001	Bullivant et al.	6,450,989 B2	9/2002	Dubrul et al.
6,324,339 B1	11/2001	Hudson et al.	6,454,781 B1	9/2002	Witt et al.
6,325,799 B1	12/2001	Goble	6,457,625 B1	10/2002	Tormala et al.
6,325,805 B1	12/2001	Ogilvie et al.	6,458,077 B1	10/2002	Boebel et al.
6,325,810 B1	12/2001	Hamilton et al.	6,458,142 B1	10/2002	Faller et al.
6,328,498 B1	12/2001	Mersch	6,458,147 B1	10/2002	Cruise et al.
6,330,965 B1	12/2001	Milliman et al.	6,460,627 B1	10/2002	Below et al.
6,331,181 B1	12/2001	Tierney et al.	6,468,275 B1	10/2002	Wampler et al.
6,331,761 B1	12/2001	Kumar et al.	6,468,286 B2	10/2002	Mastri et al.
6,333,029 B1	12/2001	Vyakarnam et al.	6,471,106 B1	10/2002	Reining
6,334,860 B1	1/2002	Dorn	6,471,659 B2	10/2002	Eggers et al.
6,334,861 B1	1/2002	Chandler et al.	6,478,210 B2	11/2002	Adams et al.
6,336,926 B1	1/2002	Goble	6,482,200 B2	11/2002	Shippert
6,338,737 B1	1/2002	Toledano	6,482,217 B1	11/2002	Pintor et al.
6,343,731 B1	2/2002	Adams et al.	6,485,490 B2	11/2002	Wampler et al.
6,346,077 B1	2/2002	Taylor et al.	6,485,503 B2	11/2002	Jacobs et al.
6,348,061 B1	2/2002	Whitman	6,485,667 B1	11/2002	Tan
6,349,868 B1	2/2002	Mattingly et al.	6,486,286 B1	11/2002	McGall et al.
D454,951 S	3/2002	Bon	6,488,196 B1	12/2002	Fenton, Jr.
6,352,503 B1	3/2002	Matsui et al.	6,488,197 B1	12/2002	Whitman

US D914,878 S

Page 12

6,488,659 B1	12/2002	Rosenman	6,596,296 B1	7/2003	Nelson et al.
6,491,201 B1	12/2002	Whitman	6,596,304 B1	7/2003	Bayon et al.
6,491,690 B1	12/2002	Goble et al.	6,596,432 B2	7/2003	Kawakami et al.
6,491,701 B2	12/2002	Tierney et al.	6,599,295 B1	7/2003	Tornier et al.
6,491,702 B2	12/2002	Heilbrun et al.	6,599,323 B2	7/2003	Melican et al.
6,492,785 B1	12/2002	Kasten et al.	D478,665 S	8/2003	Isaacs et al.
6,494,882 B1	12/2002	Lebouitz et al.	D478,986 S	8/2003	Johnston et al.
6,494,885 B1	12/2002	Dhindsa	6,601,749 B2	8/2003	Sullivan et al.
6,494,888 B1	12/2002	Laufer et al.	6,602,252 B2	8/2003	Mollenauer
6,494,896 B1	12/2002	D'Alessio et al.	6,602,262 B2	8/2003	Griego et al.
6,498,480 B1	12/2002	Manara	6,603,050 B2	8/2003	Heaton
6,500,176 B1	12/2002	Truckai et al.	6,605,078 B2	8/2003	Adams
6,500,194 B2	12/2002	Benderev et al.	6,605,669 B2	8/2003	Awokola et al.
D468,749 S	1/2003	Friedman	6,605,911 B1	8/2003	Klesing
6,503,139 B2	1/2003	Coral	6,607,475 B2	8/2003	Doyle et al.
6,503,257 B2	1/2003	Grant et al.	6,611,793 B1	8/2003	Burnside et al.
6,503,259 B2	1/2003	Huxel et al.	6,613,069 B2	9/2003	Boyd et al.
6,505,768 B2	1/2003	Whitman	6,616,686 B2	9/2003	Coleman et al.
6,506,197 B1	1/2003	Rollero et al.	6,619,529 B2	9/2003	Green et al.
6,510,854 B2	1/2003	Goble	6,620,111 B2	9/2003	Stephens et al.
6,511,468 B1	1/2003	Cragg et al.	6,620,161 B2	9/2003	Schulze et al.
6,512,360 B1	1/2003	Goto et al.	6,620,166 B1	9/2003	Wenstrom, Jr. et al.
6,514,252 B2	2/2003	Nezhat et al.	6,625,517 B1	9/2003	Bogdanov et al.
6,516,073 B1	2/2003	Schulz et al.	6,626,834 B2	9/2003	Dunne et al.
6,517,528 B1	2/2003	Pantages et al.	H2086 H	10/2003	Amsler
6,517,535 B2	2/2003	Edwards	6,629,630 B2	10/2003	Adams
6,517,565 B1	2/2003	Whitman et al.	6,629,974 B2	10/2003	Penny et al.
6,517,566 B1	2/2003	Hovland et al.	6,629,988 B2	10/2003	Weadock
6,520,971 B1	2/2003	Perry et al.	6,635,838 B1	10/2003	Kornelson
6,520,972 B2	2/2003	Peters	6,636,412 B2	10/2003	Smith
6,522,101 B2	2/2003	Malackowski	6,638,108 B2	10/2003	Tachi
6,524,180 B1	2/2003	Simms et al.	6,638,285 B2	10/2003	Gabbay
6,525,499 B2	2/2003	Naganuma	6,638,297 B1	10/2003	Huitema
D471,206 S	3/2003	Buzzard et al.	RE38,335 E	11/2003	Aust et al.
6,527,782 B2	3/2003	Hogg et al.	6,641,528 B2	11/2003	Torii
6,527,785 B2	3/2003	Sancoff et al.	6,644,532 B2	11/2003	Green et al.
6,530,942 B2	3/2003	Fogarty et al.	6,645,201 B1	11/2003	Utley et al.
6,532,958 B1	3/2003	Buan et al.	6,646,307 B1	11/2003	Yu et al.
6,533,157 B1	3/2003	Whitman	6,648,816 B2	11/2003	Irion et al.
6,533,723 B1	3/2003	Lockery et al.	6,648,901 B2	11/2003	Fleischman et al.
6,533,784 B2	3/2003	Truckai et al.	6,652,595 B1	11/2003	Nicolo
6,535,764 B2	3/2003	Imran et al.	D484,243 S	12/2003	Ryan et al.
6,539,297 B2	3/2003	Weiberle et al.	D484,595 S	12/2003	Ryan et al.
D473,239 S	4/2003	Cockerill	D484,596 S	12/2003	Ryan et al.
6,539,816 B2	4/2003	Kogiso et al.	6,656,177 B2	12/2003	Truckai et al.
6,540,737 B2	4/2003	Bacher et al.	6,656,193 B2	12/2003	Grant et al.
6,543,456 B1	4/2003	Freeman	6,659,940 B2	12/2003	Adler
6,545,384 B1	4/2003	Pelrine et al.	6,660,008 B1	12/2003	Foerster et al.
6,547,786 B1	4/2003	Goble	6,663,623 B1	12/2003	Oyama et al.
6,550,546 B2	4/2003	Thurler et al.	6,663,641 B1	12/2003	Kovac et al.
6,551,333 B2	4/2003	Kuhns et al.	6,666,854 B1	12/2003	Lange
6,554,861 B2	4/2003	Knox et al.	6,666,860 B1	12/2003	Takahashi
6,555,770 B2	4/2003	Kawase	6,666,875 B1	12/2003	Sakurai et al.
6,558,378 B2	5/2003	Sherman et al.	6,667,825 B2	12/2003	Lu et al.
6,558,379 B1	5/2003	Batchelor et al.	6,669,073 B2	12/2003	Milliman et al.
6,558,429 B2	5/2003	Taylor	6,670,806 B2	12/2003	Wendt et al.
6,561,187 B2	5/2003	Schmidt et al.	6,671,185 B2	12/2003	Duval
6,565,560 B1	5/2003	Goble et al.	D484,977 S	1/2004	Ryan et al.
6,566,619 B2	5/2003	Gillman et al.	6,676,660 B2	1/2004	Wampler et al.
6,569,085 B2	5/2003	Kortenbach et al.	6,677,687 B2	1/2004	Ho et al.
6,569,171 B2	5/2003	DeGuillebon et al.	6,679,269 B2	1/2004	Swanson
6,578,751 B2	6/2003	Hartwick	6,679,410 B2	1/2004	Wursch et al.
6,582,364 B2	6/2003	Butler et al.	6,681,978 B2	1/2004	Geiste et al.
6,582,427 B1	6/2003	Goble et al.	6,681,979 B2	1/2004	Whitman
6,582,441 B1	6/2003	He et al.	6,682,527 B2	1/2004	Strul
6,583,533 B2	6/2003	Pelrine et al.	6,682,528 B2	1/2004	Frazier et al.
6,585,144 B2	7/2003	Adams et al.	6,682,544 B2	1/2004	Mastri et al.
6,585,664 B2	7/2003	Burdorff et al.	6,685,698 B2	2/2004	Morley et al.
6,586,898 B2	7/2003	King et al.	6,685,727 B2	2/2004	Fisher et al.
6,587,750 B2	7/2003	Gerbi et al.	6,689,153 B1	2/2004	Skiba
6,588,277 B2	7/2003	Giordano et al.	6,692,507 B2	2/2004	Pugsley et al.
6,588,643 B2	7/2003	Bolduc et al.	6,692,692 B2	2/2004	Stetzel
6,588,931 B2	7/2003	Betzner et al.	6,695,198 B2	2/2004	Adams et al.
6,589,118 B1	7/2003	Soma et al.	6,695,199 B2	2/2004	Whitman
6,589,164 B1	7/2003	Flaherty	6,695,774 B2	2/2004	Hale et al.
6,592,538 B1	7/2003	Hotchkiss et al.	6,695,849 B2	2/2004	Michelson
6,592,572 B1	7/2003	Suzuta	6,696,814 B2	2/2004	Henderson et al.
6,592,597 B2	7/2003	Grant et al.	6,697,048 B2	2/2004	Rosenberg et al.
6,594,552 B1	7/2003	Nowlin et al.	6,698,643 B2	3/2004	Whitman

US D914,878 S

6,699,177	B1	3/2004	Wang et al.	6,806,808	B1	10/2004	Watters et al.
6,699,214	B2	3/2004	Gellman	6,806,867	B1	10/2004	Arruda et al.
6,699,235	B2	3/2004	Wallace et al.	6,808,525	B2	10/2004	Latterell et al.
6,704,210	B1	3/2004	Myers	6,810,359	B2	10/2004	Sakaguchi
6,705,503	B1	3/2004	Pedicini et al.	6,814,154	B2	11/2004	Chou
6,709,445	B2	3/2004	Boebel et al.	6,814,741	B2	11/2004	Bowman et al.
6,712,773	B1	3/2004	Viola	6,817,508	B1	11/2004	Racenet et al.
6,716,215	B1	4/2004	David et al.	6,817,509	B2	11/2004	Geiste et al.
6,716,223	B2	4/2004	Leopold et al.	6,817,974	B2	11/2004	Cooper et al.
6,716,232	B1	4/2004	Vidal et al.	6,818,018	B1	11/2004	Sawhney
6,716,233	B1	4/2004	Whitman	6,820,791	B2	11/2004	Adams
6,720,734	B2	4/2004	Norris	6,821,273	B2	11/2004	Mollenauer
6,722,550	B1	4/2004	Ricordi et al.	6,821,282	B2	11/2004	Perry et al.
6,722,552	B2	4/2004	Fenton, Jr.	6,821,284	B2	11/2004	Sturtz et al.
6,723,087	B2	4/2004	O'Neill et al.	6,827,246	B2	12/2004	Sullivan et al.
6,723,091	B2	4/2004	Goble et al.	6,827,712	B2	12/2004	Tovey et al.
6,723,106	B1	4/2004	Charles et al.	6,827,725	B2	12/2004	Batchelor et al.
6,723,109	B2	4/2004	Solingen	6,828,902	B2	12/2004	Casden
6,726,651	B1	4/2004	Robinson et al.	6,830,174	B2	12/2004	Hillstead et al.
6,726,697	B2	4/2004	Nicholas et al.	6,831,629	B2	12/2004	Nishino et al.
6,726,706	B2	4/2004	Dominguez	6,832,998	B2	12/2004	Goble
6,729,119	B2	5/2004	Schnipke et al.	6,834,001	B2	12/2004	Myono
6,731,976	B2	5/2004	Penn et al.	6,835,173	B2	12/2004	Couvillon, Jr.
6,736,810	B2	5/2004	Hoey et al.	6,835,199	B2	12/2004	McGuckin, Jr. et al.
6,736,825	B2	5/2004	Blatter et al.	6,835,336	B2	12/2004	Watt
6,736,854	B2	5/2004	Vadurro et al.	6,836,611	B2	12/2004	Popovic et al.
6,740,030	B2	5/2004	Martone et al.	6,837,846	B2	1/2005	Jaffe et al.
6,743,230	B2	6/2004	Lutze et al.	6,837,883	B2	1/2005	Moll et al.
6,744,385	B2	6/2004	Kazuya et al.	6,838,493	B2	1/2005	Williams et al.
6,747,121	B2	6/2004	Gogolewski	6,840,423	B2	1/2005	Adams et al.
6,747,300	B2	6/2004	Nadd et al.	6,840,938	B1	1/2005	Morley et al.
6,749,560	B1	6/2004	Konstorum et al.	6,841,967	B2	1/2005	Kim et al.
6,749,600	B1	6/2004	Levy	6,843,403	B2	1/2005	Whitman
6,752,768	B2	6/2004	Burdorff et al.	6,843,789	B2	1/2005	Goble
6,752,816	B2	6/2004	Culp et al.	6,843,793	B2	1/2005	Brock et al.
6,754,959	B1	6/2004	Guiette, III et al.	6,846,307	B2	1/2005	Whitman et al.
6,755,195	B1	6/2004	Lemke et al.	6,846,308	B2	1/2005	Whitman et al.
6,755,338	B2	6/2004	Hahnen et al.	6,846,309	B2	1/2005	Whitman et al.
6,755,843	B2	6/2004	Chung et al.	6,847,190	B2	1/2005	Schaefer et al.
6,756,705	B2	6/2004	Pulford, Jr.	6,849,071	B2	2/2005	Whitman et al.
6,758,846	B2	7/2004	Goble et al.	6,850,817	B1	2/2005	Green
6,761,685	B2	7/2004	Adams et al.	6,852,122	B2	2/2005	Rush
6,762,339	B1	7/2004	Klun et al.	6,852,330	B2	2/2005	Bowman et al.
6,763,307	B2	7/2004	Berg et al.	6,853,879	B2	2/2005	Sunaoshi
6,764,445	B2	7/2004	Ramans et al.	6,858,005	B2	2/2005	Ohline et al.
6,766,957	B2	7/2004	Matsuura et al.	6,859,882	B2	2/2005	Fung
6,767,352	B2	7/2004	Field et al.	RE38,708	E	3/2005	Bolanos et al.
6,767,356	B2	7/2004	Kanner et al.	D502,994	S	3/2005	Blake, III
6,769,590	B2	8/2004	Vresh et al.	6,861,142	B1	3/2005	Wilkie et al.
6,769,594	B2	8/2004	Orban, III	6,861,954	B2	3/2005	Levin
6,770,027	B2	8/2004	Banik et al.	6,863,668	B2	3/2005	Gillespie et al.
6,770,070	B1	8/2004	Balbierz	6,863,694	B1	3/2005	Boyce et al.
6,770,072	B1	8/2004	Truckai et al.	6,863,924	B2	3/2005	Ranganathan et al.
6,770,078	B2	8/2004	Bonutti	6,866,178	B2	3/2005	Adams et al.
6,773,409	B2	8/2004	Truckai et al.	6,866,668	B2	3/2005	Giannetti et al.
6,773,437	B2	8/2004	Ogilvie et al.	6,866,671	B2	3/2005	Tierney et al.
6,773,438	B1	8/2004	Knodel et al.	6,867,248	B1	3/2005	Martin et al.
6,775,575	B2	8/2004	Bommannan et al.	6,869,430	B2	3/2005	Balbierz et al.
6,777,838	B2	8/2004	Miekka et al.	6,869,435	B2	3/2005	Blake, III
6,778,846	B1	8/2004	Martinez et al.	6,872,214	B2	3/2005	Sonnenschein et al.
6,780,151	B2	8/2004	Grabover et al.	6,874,669	B2	4/2005	Adams et al.
6,780,180	B1	8/2004	Goble et al.	6,876,850	B2	4/2005	Maeshima et al.
6,783,524	B2	8/2004	Anderson et al.	6,877,647	B2	4/2005	Green et al.
6,784,775	B2	8/2004	Mandell et al.	6,878,106	B1	4/2005	Herrmann
6,786,382	B1	9/2004	Hoffman	6,882,127	B2	4/2005	Konigbauer
6,786,864	B2	9/2004	Matsuura et al.	6,883,199	B1	4/2005	Lundell et al.
6,786,896	B1	9/2004	Madhani et al.	6,884,392	B2	4/2005	Malkin et al.
6,788,018	B1	9/2004	Blumenkranz	6,884,428	B2	4/2005	Binette et al.
6,790,173	B2	9/2004	Saadat et al.	6,886,730	B2	5/2005	Fujisawa et al.
6,793,652	B1	9/2004	Whitman et al.	6,887,710	B2	5/2005	Call et al.
6,793,661	B2	9/2004	Hamilton et al.	6,889,116	B2	5/2005	Jinno
6,793,663	B2	9/2004	Kneifel et al.	6,893,435	B2	5/2005	Goble
6,793,669	B2	9/2004	Nakamura et al.	6,894,140	B2	5/2005	Roby
6,796,921	B1	9/2004	Buck et al.	6,895,176	B2	5/2005	Archer et al.
6,799,669	B2	10/2004	Fukumura et al.	6,899,538	B2	5/2005	Matoba
6,802,822	B1	10/2004	Dodge	6,899,593	B1	5/2005	Moeller et al.
6,802,843	B2	10/2004	Truckai et al.	6,899,705	B2	5/2005	Niemeyer
6,802,844	B2	10/2004	Ferree	6,899,915	B2	5/2005	Yelick et al.
6,805,273	B2	10/2004	Bilotti et al.	6,905,057	B2	6/2005	Swayze et al.

US D914,878 S

Page 14

6,905,497 B2	6/2005	Truckai et al.	7,000,818 B2	2/2006	Shelton, IV et al.
6,905,498 B2	6/2005	Hooven	7,000,819 B2	2/2006	Swayze et al.
6,908,472 B2	6/2005	Wiener et al.	7,000,911 B2	2/2006	McCormick et al.
6,911,033 B2	6/2005	de Guillebon et al.	7,001,380 B2	2/2006	Goble
6,911,916 B1	6/2005	Wang et al.	7,001,408 B2	2/2006	Knodel et al.
6,913,579 B2	7/2005	Truckai et al.	7,004,174 B2	2/2006	Eggers et al.
6,913,608 B2	7/2005	Liddicoat et al.	7,007,176 B2	2/2006	Goodfellow et al.
6,913,613 B2	7/2005	Schwarz et al.	7,008,433 B2	3/2006	Voellmicke et al.
6,921,397 B2	7/2005	Corcoran et al.	7,008,435 B2	3/2006	Cummins
6,921,412 B1	7/2005	Black et al.	7,009,039 B2	3/2006	Yayon et al.
6,923,093 B2	8/2005	Ullah	7,011,213 B2	3/2006	Clark et al.
6,923,803 B2	8/2005	Goble	7,011,657 B2	3/2006	Truckai et al.
6,923,819 B2	8/2005	Meade et al.	7,014,640 B2	3/2006	Kemppainen et al.
6,925,849 B2	8/2005	Jairam	7,018,357 B2	3/2006	Emmons
6,926,716 B2	8/2005	Baker et al.	7,018,390 B2	3/2006	Turovskiy et al.
6,928,902 B1	8/2005	Eyssalenne	7,021,669 B1	4/2006	Lindermeir et al.
6,929,641 B2	8/2005	Goble et al.	7,022,131 B1	4/2006	Derowe et al.
6,929,644 B2	8/2005	Truckai et al.	7,023,159 B2	4/2006	Gorti et al.
6,931,830 B2	8/2005	Liao	7,025,064 B2	4/2006	Wang et al.
6,932,218 B2	8/2005	Kosann et al.	7,025,732 B2	4/2006	Thompson et al.
6,932,810 B2	8/2005	Ryan	7,025,743 B2	4/2006	Mann et al.
6,936,042 B2	8/2005	Wallace et al.	7,025,774 B2	4/2006	Freeman et al.
6,936,948 B2	8/2005	Bell et al.	7,025,775 B2	4/2006	Gadberry et al.
D509,297 S	9/2005	Wells	7,028,570 B2	4/2006	Ohta et al.
D509,589 S	9/2005	Wells	7,029,435 B2	4/2006	Nakao
6,938,706 B2	9/2005	Ng	7,029,439 B2	4/2006	Roberts et al.
6,939,358 B2	9/2005	Palacios et al.	7,030,904 B2	4/2006	Adair et al.
6,942,662 B2	9/2005	Goble et al.	7,032,798 B2	4/2006	Whitman et al.
6,942,674 B2	9/2005	Belef et al.	7,032,799 B2	4/2006	Viola et al.
6,945,444 B2	9/2005	Gresham et al.	7,033,356 B2	4/2006	Latterell et al.
6,945,981 B2	9/2005	Donofrio et al.	7,033,378 B2	4/2006	Smith et al.
6,951,562 B2	10/2005	Zwirnmann	7,035,716 B2	4/2006	Harris et al.
6,953,138 B1	10/2005	Dworak et al.	7,035,762 B2	4/2006	Menard et al.
6,953,139 B2	10/2005	Milliman et al.	7,036,680 B1	5/2006	Flannery
6,953,461 B2	10/2005	McClurken et al.	7,037,314 B2	5/2006	Armstrong
6,957,758 B2	10/2005	Aranyi	7,037,344 B2	5/2006	Kagan et al.
6,958,035 B2	10/2005	Friedman et al.	7,041,088 B2	5/2006	Nawrocki et al.
D511,525 S	11/2005	Hernandez et al.	7,041,102 B2	5/2006	Truckai et al.
6,959,851 B2	11/2005	Heinrich	7,041,868 B2	5/2006	Greene et al.
6,959,852 B2	11/2005	Shelton, IV et al.	7,043,852 B2	5/2006	Hayashida et al.
6,960,107 B1	11/2005	Schaub et al.	7,044,350 B2	5/2006	Kameyama et al.
6,960,163 B2	11/2005	Ewers et al.	7,044,352 B2	5/2006	Shelton, IV et al.
6,960,220 B2	11/2005	Marino et al.	7,044,353 B2	5/2006	Mastri et al.
6,962,587 B2	11/2005	Johnson et al.	7,046,082 B2	5/2006	Komiya et al.
6,963,792 B1	11/2005	Green	7,048,165 B2	5/2006	Haramiishi
6,964,363 B2	11/2005	Wales et al.	7,048,687 B1	5/2006	Reuss et al.
6,966,907 B2	11/2005	Goble	7,048,716 B1	5/2006	Kucharczyk et al.
6,966,909 B2	11/2005	Marshall et al.	7,048,745 B2	5/2006	Tierney et al.
6,968,908 B2	11/2005	Tokunaga et al.	7,052,454 B2	5/2006	Taylor
6,969,385 B2	11/2005	Moreyra	7,052,494 B2	5/2006	Goble et al.
6,969,395 B2	11/2005	Eskuri	7,052,499 B2	5/2006	Steger et al.
6,971,988 B2	12/2005	Orban, III	7,055,730 B2	6/2006	Ehrenfels et al.
6,972,199 B2	12/2005	Lebouitz et al.	7,055,731 B2	6/2006	Shelton, IV et al.
6,974,435 B2	12/2005	Daw et al.	7,056,123 B2	6/2006	Gregorio et al.
6,974,462 B2	12/2005	Sater	7,056,284 B2	6/2006	Martone et al.
6,978,921 B2	12/2005	Shelton, IV et al.	7,056,330 B2	6/2006	Gayton
6,978,922 B2	12/2005	Bilotti et al.	7,059,331 B2	6/2006	Adams et al.
6,981,628 B2	1/2006	Wales	7,059,508 B2	6/2006	Shelton, IV et al.
6,981,941 B2	1/2006	Whitman et al.	7,063,671 B2	6/2006	Couvillon, Jr.
6,981,978 B2	1/2006	Gannoe	7,063,712 B2	6/2006	Vargas et al.
6,984,203 B2	1/2006	Tartaglia et al.	7,064,509 B1	6/2006	Fu et al.
6,984,231 B2	1/2006	Goble et al.	7,066,879 B2	6/2006	Fowler et al.
6,986,451 B1	1/2006	Mastri et al.	7,066,944 B2	6/2006	Laufer et al.
6,988,649 B2	1/2006	Shelton, IV et al.	7,067,038 B2	6/2006	Trokhon et al.
6,988,650 B2	1/2006	Schwemberger et al.	7,070,083 B2	7/2006	Jankowski
6,989,034 B2	1/2006	Hammer et al.	7,070,559 B2	7/2006	Adams et al.
6,990,731 B2	1/2006	Haytayan	7,070,597 B2	7/2006	Truckai et al.
6,990,796 B2	1/2006	Schnipke et al.	7,071,287 B2	7/2006	Rhine et al.
6,991,146 B2	1/2006	Sinisi et al.	7,075,770 B1	7/2006	Smith
6,993,200 B2	1/2006	Tastl et al.	7,077,856 B2	7/2006	Whitman
6,993,413 B2	1/2006	Sunaoshi	7,080,769 B2	7/2006	Vresh et al.
6,994,708 B2	2/2006	Manzo	7,081,114 B2	7/2006	Rashidi
6,995,729 B2	2/2006	Govari et al.	7,083,073 B2	8/2006	Yoshie et al.
6,996,433 B2	2/2006	Burbank et al.	7,083,075 B2	8/2006	Swayze et al.
6,997,931 B2	2/2006	Sauer et al.	7,083,571 B2	8/2006	Wang et al.
6,997,935 B2	2/2006	Anderson et al.	7,083,615 B2	8/2006	Peterson et al.
6,998,736 B2	2/2006	Lee et al.	7,083,619 B2	8/2006	Truckai et al.
6,998,816 B2	2/2006	Wieck et al.	7,083,620 B2	8/2006	Jahns et al.
6,999,821 B2	2/2006	Jenney et al.	7,083,626 B2	8/2006	Hart et al.

US D914,878 S

7,086,267 B2	8/2006	Dworak et al.	7,161,036 B2	1/2007	Oikawa et al.
7,087,049 B2	8/2006	Nowlin et al.	7,161,580 B2	1/2007	Bailey et al.
7,087,054 B2	8/2006	Truckai et al.	7,162,758 B2	1/2007	Skinner
7,087,071 B2	8/2006	Nicholas et al.	7,163,563 B2	1/2007	Schwartz et al.
7,090,637 B2	8/2006	Danitz et al.	7,166,117 B2	1/2007	Hellenkamp
7,090,673 B2	8/2006	Dycus et al.	7,166,133 B2	1/2007	Evans et al.
7,090,683 B2	8/2006	Brock et al.	7,168,604 B2	1/2007	Milliman et al.
7,090,684 B2	8/2006	McGuckin, Jr. et al.	7,170,910 B2	1/2007	Chen et al.
7,091,191 B2	8/2006	Laredo et al.	7,171,279 B2	1/2007	Buckingham et al.
7,091,412 B2	8/2006	Wang et al.	7,172,104 B2	2/2007	Scirica et al.
7,093,492 B2	8/2006	Treiber et al.	7,172,593 B2	2/2007	Trieu et al.
7,094,202 B2	8/2006	Nobis et al.	7,172,615 B2	2/2007	Morriss et al.
7,094,247 B2	8/2006	Monassevitch et al.	7,174,202 B2	2/2007	Bladen et al.
7,094,916 B2	8/2006	DeLuca et al.	7,174,636 B2	2/2007	Lowe
7,096,972 B2	8/2006	Orozco, Jr.	7,177,533 B2	2/2007	McFarlin et al.
7,097,089 B2	8/2006	Marczyk	7,179,223 B2	2/2007	Motoki et al.
7,097,644 B2	8/2006	Long	7,179,267 B2	2/2007	Nolan et al.
7,097,650 B2	8/2006	Weller et al.	7,182,239 B1	2/2007	Myers
7,098,794 B2	8/2006	Lindsay et al.	7,182,763 B2	2/2007	Nardella
7,100,949 B2	9/2006	Williams et al.	7,183,737 B2	2/2007	Kitagawa
7,101,187 B1	9/2006	Deconinck et al.	7,187,960 B2	3/2007	Abreu
7,101,371 B2	9/2006	Dycus et al.	7,188,758 B2	3/2007	Viola et al.
7,101,394 B2	9/2006	Hamm et al.	7,189,207 B2	3/2007	Viola
7,104,741 B2	9/2006	Krohn	7,190,147 B2	3/2007	Gileff et al.
7,108,695 B2	9/2006	Witt et al.	7,193,199 B2	3/2007	Jang
7,108,701 B2	9/2006	Evens et al.	7,195,627 B2	3/2007	Amoah et al.
7,108,709 B2	9/2006	Cummins	7,196,911 B2	3/2007	Takano et al.
7,111,768 B2	9/2006	Cummins et al.	D541,418 S	4/2007	Schechter et al.
7,111,769 B2	9/2006	Wales et al.	7,199,537 B2	4/2007	Okamura et al.
7,112,214 B2	9/2006	Peterson et al.	7,199,545 B2	4/2007	Oleynikov et al.
RE39,358 E	10/2006	Goble	7,202,576 B1	4/2007	Dechene et al.
D530,339 S	10/2006	Hernandez et al.	7,202,653 B2	4/2007	Pai
7,114,642 B2	10/2006	Whitman	7,204,404 B2	4/2007	Nguyen et al.
7,116,100 B1	10/2006	Mock et al.	7,204,835 B2	4/2007	Latterell et al.
7,118,020 B2	10/2006	Lee et al.	7,206,626 B2	4/2007	Quaid, III
7,118,528 B1	10/2006	Piskun	7,207,233 B2	4/2007	Wadge
7,118,563 B2	10/2006	Weckwerth et al.	7,207,471 B2	4/2007	Heinrich et al.
7,118,582 B1	10/2006	Wang et al.	7,207,472 B2	4/2007	Wukusick et al.
7,119,534 B2	10/2006	Butzmann	7,207,556 B2	4/2007	Saitoh et al.
7,121,446 B2	10/2006	Arad et al.	7,208,005 B2	4/2007	Frecker et al.
7,121,773 B2	10/2006	Mikiya et al.	7,210,609 B2	5/2007	Leiboff et al.
7,122,028 B2	10/2006	Looper et al.	7,211,081 B2	5/2007	Goble
7,125,403 B2	10/2006	Julian et al.	7,211,084 B2	5/2007	Goble et al.
7,125,409 B2	10/2006	Truckai et al.	7,211,092 B2	5/2007	Hughett
7,126,303 B2	10/2006	Farritor et al.	7,211,979 B2	5/2007	Khatib et al.
7,126,879 B2	10/2006	Snyder	7,213,736 B2	5/2007	Wales et al.
7,128,253 B2	10/2006	Mastri et al.	7,214,224 B2	5/2007	Goble
7,128,254 B2	10/2006	Shelton, IV et al.	7,215,517 B2	5/2007	Takamatsu
7,128,748 B2	10/2006	Mooradian et al.	7,217,285 B2	5/2007	Vargas et al.
7,131,445 B2	11/2006	Amoah	7,220,260 B2	5/2007	Fleming et al.
7,133,601 B2	11/2006	Phillips et al.	7,220,272 B2	5/2007	Weadock
7,134,364 B2	11/2006	Kageler et al.	7,225,959 B2	6/2007	Patton et al.
7,134,587 B2	11/2006	Schwemberger et al.	7,225,963 B2	6/2007	Scirica
7,135,027 B2	11/2006	Delmotte	7,225,964 B2	6/2007	Mastri et al.
7,137,980 B2	11/2006	Buysse et al.	7,226,450 B2	6/2007	Athanasidou et al.
7,137,981 B2	11/2006	Long	7,228,505 B2	6/2007	Shimazu et al.
7,139,016 B2	11/2006	Squilla et al.	7,229,408 B2	6/2007	Douglas et al.
7,140,527 B2	11/2006	Ehrenfels et al.	7,234,624 B2	6/2007	Gresham et al.
7,140,528 B2	11/2006	Shelton, IV	7,235,072 B2	6/2007	Sartor et al.
7,141,055 B2	11/2006	Abrams et al.	7,235,089 B1	6/2007	McGuckin, Jr.
7,143,923 B2	12/2006	Shelton, IV et al.	7,235,302 B2	6/2007	Jing et al.
7,143,924 B2	12/2006	Scirica et al.	7,237,708 B1	7/2007	Guy et al.
7,143,925 B2	12/2006	Shelton, IV et al.	7,238,195 B2	7/2007	Viola
7,143,926 B2	12/2006	Shelton, IV et al.	7,238,901 B2	7/2007	Kim et al.
7,146,191 B2	12/2006	Kerner et al.	7,239,657 B1	7/2007	Gunnarsson
7,147,138 B2	12/2006	Shelton, IV	7,241,288 B2	7/2007	Braun
7,147,139 B2	12/2006	Schwemberger et al.	7,241,289 B2	7/2007	Braun
7,147,140 B2	12/2006	Wukusick et al.	7,246,734 B2	7/2007	Shelton, IV
7,147,637 B2	12/2006	Goble	7,247,161 B2	7/2007	Johnston et al.
7,147,648 B2	12/2006	Lin	7,249,267 B2	7/2007	Chapuis
7,147,650 B2	12/2006	Lee	7,252,641 B2	8/2007	Thompson et al.
7,150,748 B2	12/2006	Ebbutt et al.	7,252,660 B2	8/2007	Kunz
7,153,300 B2	12/2006	Goble	7,255,012 B2	8/2007	Hedtke
7,153,314 B2	12/2006	Laufer et al.	7,255,696 B2	8/2007	Goble et al.
7,155,316 B2	12/2006	Sutherland et al.	7,256,695 B2	8/2007	Hamel et al.
7,156,863 B2	1/2007	Sonnenschein et al.	7,258,262 B2	8/2007	Mastri et al.
7,159,750 B2	1/2007	Racenet et al.	7,258,546 B2	8/2007	Beier et al.
7,160,296 B2	1/2007	Pearson et al.	7,260,431 B2	8/2007	Libbus et al.
7,160,299 B2	1/2007	Baily	7,265,374 B2	9/2007	Lee et al.

US D914,878 S

7,267,677 B2	9/2007	Johnson et al.	7,364,060 B2	4/2008	Milliman
7,267,679 B2	9/2007	McGuckin, Jr. et al.	7,364,061 B2	4/2008	Swayze et al.
7,272,002 B2	9/2007	Drapeau	7,367,485 B2	5/2008	Shelton, IV et al.
7,273,483 B2	9/2007	Wiener et al.	7,368,124 B2	5/2008	Chun et al.
D552,623 S	10/2007	Vong et al.	7,371,210 B2	5/2008	Brock et al.
7,275,674 B2	10/2007	Racenet et al.	7,371,403 B2	5/2008	McCarthy et al.
7,276,044 B2	10/2007	Ferry et al.	7,375,493 B2	5/2008	Calhoon et al.
7,276,068 B2	10/2007	Johnson et al.	7,377,918 B2	5/2008	Amoah
7,278,562 B2	10/2007	Mastri et al.	7,377,928 B2	5/2008	Zubik et al.
7,278,563 B1	10/2007	Green	7,378,817 B2	5/2008	Calhoon et al.
7,278,949 B2	10/2007	Bader	RE40,388 E	6/2008	Gines
7,278,994 B2	10/2007	Goble	D570,868 S	6/2008	Hosokawa et al.
7,282,048 B2	10/2007	Goble et al.	7,380,695 B2	6/2008	Doll et al.
7,283,096 B2	10/2007	Geisheimer et al.	7,380,696 B2	6/2008	Shelton, IV et al.
7,286,850 B2	10/2007	Frielink et al.	7,384,403 B2	6/2008	Sherman
7,287,682 B1	10/2007	Ezzat et al.	7,384,417 B2	6/2008	Cucin
7,289,139 B2	10/2007	Amling et al.	7,386,365 B2	6/2008	Nixon
7,293,685 B2	11/2007	Ehrenfels et al.	7,386,730 B2	6/2008	Uchikubo
7,295,893 B2	11/2007	Sunaoshi	7,388,217 B2	6/2008	Buschbeck et al.
7,295,907 B2	11/2007	Lu et al.	7,388,484 B2	6/2008	Hsu
7,296,722 B2	11/2007	Ivanko	7,391,173 B2	6/2008	Schena
7,296,724 B2	11/2007	Green et al.	7,394,190 B2	7/2008	Huang
7,297,149 B2	11/2007	Vitali et al.	7,396,356 B2	7/2008	Mollenauer
7,300,373 B2	11/2007	Jinno et al.	7,397,364 B2	7/2008	Govari
7,300,431 B2	11/2007	Dubrovsky	7,398,707 B2	7/2008	Morley et al.
7,300,450 B2	11/2007	Vleugels et al.	7,398,907 B2	7/2008	Racenet et al.
7,303,106 B2	12/2007	Milliman et al.	7,398,908 B2	7/2008	Holsten et al.
7,303,107 B2	12/2007	Milliman et al.	7,400,107 B2	7/2008	Schneider et al.
7,303,108 B2	12/2007	Shelton, IV	7,400,752 B2	7/2008	Zacharias
7,303,502 B2	12/2007	Thompson	7,401,000 B2	7/2008	Nakamura
7,303,556 B2	12/2007	Metzger	7,401,721 B2	7/2008	Holsten et al.
7,306,597 B2	12/2007	Manzo	7,404,449 B2	7/2008	Birmingham et al.
7,308,998 B2	12/2007	Mastri et al.	7,404,508 B2	7/2008	Smith et al.
7,311,238 B2	12/2007	Liu	7,404,509 B2	7/2008	Ortiz et al.
7,313,430 B2	12/2007	Urquhart et al.	7,404,822 B2	7/2008	Viart et al.
7,314,473 B2	1/2008	Jinno et al.	D575,793 S	8/2008	Ording
7,322,859 B2	1/2008	Evans	7,407,074 B2	8/2008	Ortiz et al.
7,322,975 B2	1/2008	Goble et al.	7,407,075 B2	8/2008	Holsten et al.
7,322,994 B2	1/2008	Nicholas et al.	7,407,076 B2	8/2008	Racenet et al.
7,324,572 B2	1/2008	Chang	7,407,077 B2	8/2008	Ortiz et al.
7,326,203 B2	2/2008	Papineau et al.	7,407,078 B2	8/2008	Shelton, IV et al.
7,326,213 B2	2/2008	Benderev et al.	7,408,310 B2	8/2008	Hong et al.
7,328,828 B2	2/2008	Ortiz et al.	7,410,085 B2	8/2008	Wolf et al.
7,328,829 B2	2/2008	Arad et al.	7,410,086 B2	8/2008	Ortiz et al.
7,330,004 B2	2/2008	Dejonge et al.	7,410,483 B2	8/2008	Danitz et al.
7,331,340 B2	2/2008	Barney	7,413,563 B2	8/2008	Corcoran et al.
7,331,343 B2	2/2008	Schmidt et al.	7,416,101 B2	8/2008	Shelton, IV et al.
7,331,403 B2	2/2008	Berry et al.	7,418,078 B2	8/2008	Blanz et al.
7,331,406 B2	2/2008	Wottreng, Jr. et al.	RE40,514 E	9/2008	Mastri et al.
7,331,969 B1	2/2008	Ingas et al.	7,419,080 B2	9/2008	Smith et al.
7,334,717 B2	2/2008	Rethy et al.	7,419,081 B2	9/2008	Ehrenfels et al.
7,334,718 B2	2/2008	McAlister et al.	7,419,321 B2	9/2008	Tereschouk
7,335,199 B2	2/2008	Goble et al.	7,419,495 B2	9/2008	Menn et al.
7,335,401 B2	2/2008	Finke et al.	7,422,136 B1	9/2008	Marczyk
7,336,045 B2	2/2008	Clermonts	7,422,138 B2	9/2008	Bilotti et al.
7,336,048 B2	2/2008	Lohr	7,422,139 B2	9/2008	Shelton, IV et al.
7,336,184 B2	2/2008	Smith et al.	7,424,965 B2	9/2008	Racenet et al.
7,337,774 B2	3/2008	Webb	7,427,607 B2	9/2008	Suzuki
7,338,505 B2	3/2008	Belson	D578,644 S	10/2008	Shumer et al.
7,338,513 B2	3/2008	Lee et al.	7,430,772 B2	10/2008	Van Es
7,341,554 B2	3/2008	Sekine et al.	7,431,188 B1	10/2008	Marczyk
7,341,555 B2	3/2008	Ootawara et al.	7,431,189 B2	10/2008	Shelton, IV et al.
7,341,591 B2	3/2008	Grinberg	7,431,230 B2	10/2008	McPherson et al.
7,343,920 B2	3/2008	Toby et al.	7,431,694 B2	10/2008	Stefanchik et al.
7,344,532 B2	3/2008	Goble et al.	7,431,730 B2	10/2008	Viola
7,344,533 B2	3/2008	Pearson et al.	7,434,715 B2	10/2008	Shelton, IV et al.
7,346,344 B2	3/2008	Fontaine	7,434,717 B2	10/2008	Shelton, IV et al.
7,346,406 B2	3/2008	Brotto et al.	7,435,249 B2	10/2008	Buysse et al.
7,348,763 B1	3/2008	Reinhart et al.	7,438,209 B1	10/2008	Hess et al.
7,348,875 B2	3/2008	Hughes et al.	7,438,718 B2	10/2008	Milliman et al.
RE40,237 E	4/2008	Bilotti et al.	7,439,354 B2	10/2008	Lenges et al.
7,351,258 B2	4/2008	Ricotta et al.	7,441,684 B2	10/2008	Shelton, IV et al.
7,354,447 B2	4/2008	Shelton, IV et al.	7,441,685 B1	10/2008	Boudreaux
7,354,502 B2	4/2008	Polat et al.	7,442,201 B2	10/2008	Pugsley et al.
7,357,287 B2	4/2008	Shelton, IV et al.	7,443,547 B2	10/2008	Moreno et al.
7,357,806 B2	4/2008	Rivera et al.	7,446,131 B1	11/2008	Liu et al.
7,361,168 B2	4/2008	Makower et al.	7,448,525 B2	11/2008	Shelton, IV et al.
7,361,195 B2	4/2008	Schwartz et al.	7,450,010 B1	11/2008	Gravelle et al.
7,362,062 B2	4/2008	Schneider et al.	7,450,991 B2	11/2008	Smith et al.

US D914,878 S

Page 17

7,451,904 B2	11/2008	Shelton, IV	7,559,937 B2	7/2009	de la Torre et al.
7,455,208 B2	11/2008	Wales et al.	7,561,637 B2	7/2009	Jonsson et al.
7,455,676 B2	11/2008	Holsten et al.	7,562,910 B2	7/2009	Kertesz et al.
7,455,682 B2	11/2008	Viola	7,563,269 B2	7/2009	Hashiguchi
7,455,687 B2	11/2008	Saunders et al.	7,563,862 B2	7/2009	Sieg et al.
D582,934 S	12/2008	Byeon	7,565,993 B2	7/2009	Milliman et al.
7,461,767 B2	12/2008	Viola et al.	7,566,300 B2	7/2009	Devierre et al.
7,462,187 B2	12/2008	Johnston et al.	7,567,045 B2	7/2009	Fristedt
7,464,845 B2	12/2008	Chou	7,568,603 B2	8/2009	Shelton, IV et al.
7,464,846 B2	12/2008	Shelton, IV et al.	7,568,604 B2	8/2009	Ehrenfels et al.
7,464,847 B2	12/2008	Viola et al.	7,568,619 B2	8/2009	Todd et al.
7,464,848 B2	12/2008	Green et al.	7,572,285 B2	8/2009	Frey et al.
7,464,849 B2	12/2008	Shelton, IV et al.	7,575,144 B2	8/2009	Ortiz et al.
7,467,740 B2	12/2008	Shelton, IV et al.	7,578,825 B2	8/2009	Huebner
7,467,849 B2	12/2008	Silverbrook et al.	D600,712 S	9/2009	LaManna et al.
7,472,814 B2	1/2009	Mastri et al.	7,583,063 B2	9/2009	Dooley
7,472,815 B2	1/2009	Shelton, IV et al.	7,584,880 B2	9/2009	Racenet et al.
7,472,816 B2	1/2009	Holsten et al.	7,586,289 B2	9/2009	Andruk et al.
7,473,221 B2	1/2009	Ewers et al.	7,588,174 B2	9/2009	Holsten et al.
7,473,253 B2	1/2009	Dycus et al.	7,588,175 B2	9/2009	Timm et al.
7,473,263 B2	1/2009	Johnston et al.	7,588,176 B2	9/2009	Timm et al.
7,476,237 B2	1/2009	Taniguchi et al.	7,588,177 B2	9/2009	Racenet
7,479,147 B2	1/2009	Honeycutt et al.	7,591,783 B2	9/2009	Boulais et al.
7,479,608 B2	1/2009	Smith	7,591,818 B2	9/2009	Bertolero et al.
7,481,347 B2	1/2009	Roy	7,593,766 B2	9/2009	Faber et al.
7,481,348 B2	1/2009	Marczyk	7,595,642 B2	9/2009	Doyle
7,481,349 B2	1/2009	Holsten et al.	7,597,229 B2	10/2009	Boudreaux et al.
7,481,824 B2	1/2009	Boudreaux et al.	7,597,230 B2	10/2009	Racenet et al.
7,485,124 B2	2/2009	Kuhns et al.	7,597,693 B2	10/2009	Garrison
7,485,133 B2	2/2009	Cannon et al.	7,597,699 B2	10/2009	Rogers
7,485,142 B2	2/2009	Milo	7,598,972 B2	10/2009	Tomita
7,487,899 B2	2/2009	Shelton, IV et al.	7,600,663 B2	10/2009	Green
7,489,055 B2	2/2009	Jeong et al.	7,604,118 B2	10/2009	Iio et al.
7,490,749 B2	2/2009	Schall et al.	7,604,150 B2	10/2009	Boudreaux
7,491,232 B2	2/2009	Bolduc et al.	7,604,151 B2	10/2009	Hess et al.
7,494,039 B2	2/2009	Racenet et al.	7,604,668 B2	10/2009	Farnsworth et al.
7,494,460 B2	2/2009	Haarstad et al.	7,607,557 B2	10/2009	Shelton, IV et al.
7,494,499 B2	2/2009	Nagase et al.	7,608,091 B2	10/2009	Goldfarb et al.
7,494,501 B2	2/2009	Ahlberg et al.	D604,325 S	11/2009	Ebeling et al.
7,500,979 B2	3/2009	Hueil et al.	7,611,038 B2	11/2009	Racenet et al.
7,501,198 B2	3/2009	Barlev et al.	7,611,474 B2	11/2009	Hibner et al.
7,503,474 B2	3/2009	Hillstead et al.	7,615,003 B2	11/2009	Stefanchik et al.
7,506,790 B2	3/2009	Shelton, IV	7,615,006 B2	11/2009	Abe
7,506,791 B2	3/2009	Omaits et al.	7,615,067 B2	11/2009	Lee et al.
7,507,202 B2	3/2009	Schoellhorn	7,617,961 B2	11/2009	Viola
7,510,107 B2	3/2009	Timm et al.	D605,201 S	12/2009	Lorenz et al.
7,510,534 B2	3/2009	Burdorff et al.	D606,992 S	12/2009	Liu et al.
7,510,566 B2	3/2009	Jacobs et al.	D607,010 S	12/2009	Kocmick
7,513,407 B1	4/2009	Chang	7,624,902 B2	12/2009	Marczyk et al.
7,513,408 B2	4/2009	Shelton, IV et al.	7,624,903 B2	12/2009	Green et al.
7,517,356 B2	4/2009	Heinrich	7,625,370 B2	12/2009	Hart et al.
7,524,320 B2	4/2009	Tierney et al.	7,625,388 B2	12/2009	Boukhny et al.
7,527,632 B2	5/2009	Houghton et al.	7,630,841 B2	12/2009	Comisky et al.
7,530,984 B2	5/2009	Sonnenschein et al.	7,631,793 B2	12/2009	Rethy et al.
7,530,985 B2	5/2009	Takemoto et al.	7,631,794 B2	12/2009	Rethy et al.
7,533,906 B2	5/2009	Luetzgen et al.	7,635,074 B2	12/2009	Olson et al.
7,534,259 B2	5/2009	Lashinski et al.	7,635,922 B2	12/2009	Becker
7,540,867 B2	6/2009	Jinno et al.	7,637,409 B2	12/2009	Marczyk
7,540,872 B2	6/2009	Schechter et al.	7,637,410 B2	12/2009	Marczyk
7,542,807 B2	6/2009	Bertolero et al.	7,638,958 B2	12/2009	Philipp et al.
7,543,730 B1	6/2009	Marczyk	7,641,091 B2	1/2010	Olson et al.
7,544,197 B2	6/2009	Kelsch et al.	7,641,092 B2	1/2010	Kruszynski et al.
7,546,939 B2	6/2009	Adams et al.	7,641,093 B2	1/2010	Doll et al.
7,546,940 B2	6/2009	Milliman et al.	7,641,095 B2	1/2010	Viola
7,547,287 B2	6/2009	Boecker et al.	7,641,671 B2	1/2010	Crainich
7,547,312 B2	6/2009	Bauman et al.	7,644,783 B2	1/2010	Roberts et al.
7,549,563 B2	6/2009	Mather et al.	7,644,848 B2	1/2010	Swayze et al.
7,549,564 B2	6/2009	Boudreaux	7,645,230 B2	1/2010	Mikkaichi et al.
7,549,998 B2	6/2009	Braun	7,648,055 B2	1/2010	Marczyk
7,552,854 B2	6/2009	Wixey et al.	7,648,457 B2	1/2010	Stefanchik et al.
7,553,173 B2	6/2009	Kowalick	7,648,519 B2	1/2010	Lee et al.
7,553,275 B2	6/2009	Padget et al.	7,650,185 B2	1/2010	Maile et al.
7,554,343 B2	6/2009	Bromfield	7,651,017 B2	1/2010	Ortiz et al.
7,556,185 B2	7/2009	Viola	7,651,498 B2	1/2010	Shifrin et al.
7,556,186 B2	7/2009	Milliman	7,654,431 B2	2/2010	Hueil et al.
7,556,647 B2	7/2009	Drews et al.	7,655,003 B2	2/2010	Lorang et al.
7,559,449 B2	7/2009	Viola	7,655,004 B2	2/2010	Long
7,559,450 B2	7/2009	Wales et al.	7,655,288 B2	2/2010	Bauman et al.
7,559,452 B2	7/2009	Wales et al.	7,655,584 B2	2/2010	Biran et al.

US D914,878 S

Page 18

7,656,131 B2	2/2010	Embrey et al.	7,727,954 B2	6/2010	McKay
7,658,311 B2	2/2010	Boudreaux	7,728,553 B2	6/2010	Carrier et al.
7,658,312 B2	2/2010	Vidal et al.	7,729,742 B2	6/2010	Govari
7,658,705 B2	2/2010	Melvin et al.	7,731,072 B2	6/2010	Timm et al.
7,659,219 B2	2/2010	Biran et al.	7,731,073 B2	6/2010	Wixey et al.
7,661,448 B2	2/2010	Kim et al.	7,731,724 B2	6/2010	Huitema et al.
7,662,161 B2	2/2010	Briganti et al.	7,735,703 B2	6/2010	Morgan et al.
7,665,646 B2	2/2010	Prommersberger	7,736,254 B2	6/2010	Schena
7,665,647 B2	2/2010	Shelton, IV et al.	7,736,306 B2	6/2010	Brustad et al.
7,666,195 B2	2/2010	Kelleher et al.	7,736,374 B2	6/2010	Vaughan et al.
7,669,746 B2	3/2010	Shelton, IV	7,738,971 B2	6/2010	Swayze et al.
7,669,747 B2	3/2010	Weisenburgh, II et al.	7,740,159 B2	6/2010	Shelton, IV et al.
7,670,334 B2	3/2010	Hueil et al.	7,742,036 B2	6/2010	Grant et al.
7,673,780 B2	3/2010	Shelton, IV et al.	7,743,960 B2	6/2010	Whitman et al.
7,673,781 B2	3/2010	Swayze et al.	7,744,624 B2	6/2010	Bettuchi
7,673,782 B2	3/2010	Hess et al.	7,744,627 B2	6/2010	Orban, III et al.
7,673,783 B2	3/2010	Morgan et al.	7,744,628 B2	6/2010	Viola
7,674,253 B2	3/2010	Fisher et al.	7,747,146 B2	6/2010	Milano et al.
7,674,255 B2	3/2010	Braun	7,748,587 B2	7/2010	Haramiishi et al.
7,674,263 B2	3/2010	Ryan	7,748,632 B2	7/2010	Coleman et al.
7,674,270 B2	3/2010	Layer	7,749,204 B2	7/2010	Dhanaraj et al.
7,678,121 B1	3/2010	Knodel	7,749,240 B2	7/2010	Takahashi et al.
7,682,307 B2	3/2010	Danitz et al.	7,751,870 B2	7/2010	Whitman
7,682,367 B2	3/2010	Shah et al.	7,753,245 B2	7/2010	Boudreaux et al.
7,682,686 B2	3/2010	Curro et al.	7,753,246 B2	7/2010	Scirica
7,686,201 B2	3/2010	Csiky	7,753,904 B2	7/2010	Shelton, IV et al.
7,686,804 B2	3/2010	Johnson et al.	7,757,924 B2	7/2010	Gerbi et al.
7,686,826 B2	3/2010	Lee et al.	7,758,594 B2	7/2010	Lamson et al.
7,688,028 B2	3/2010	Phillips et al.	7,758,612 B2	7/2010	Shipp
7,690,547 B2	4/2010	Racenet et al.	7,758,613 B2	7/2010	Whitman
7,691,098 B2	4/2010	Wallace et al.	7,762,462 B2	7/2010	Gelbman
7,691,103 B2	4/2010	Fernandez et al.	7,762,998 B2	7/2010	Birk et al.
7,691,106 B2	4/2010	Schenberger et al.	D622,286 S	8/2010	Umezawa
7,694,864 B2	4/2010	Okada et al.	7,766,207 B2	8/2010	Mather et al.
7,694,865 B2	4/2010	Scirica	7,766,209 B2	8/2010	Baxter, III et al.
7,695,485 B2	4/2010	Whitman et al.	7,766,210 B2	8/2010	Shelton, IV et al.
7,695,493 B2	4/2010	Saadat et al.	7,766,821 B2	8/2010	Brunnen et al.
7,699,204 B2	4/2010	Viola	7,766,894 B2	8/2010	Weitzner et al.
7,699,835 B2	4/2010	Lee et al.	7,770,658 B2	8/2010	Ito et al.
7,699,844 B2	4/2010	Utley et al.	7,770,773 B2	8/2010	Whitman et al.
7,699,846 B2	4/2010	Ryan	7,770,774 B2	8/2010	Mastri et al.
7,699,856 B2	4/2010	Van Wyk et al.	7,770,775 B2	8/2010	Shelton, IV et al.
7,699,859 B2	4/2010	Bombard et al.	7,770,776 B2	8/2010	Chen et al.
7,699,860 B2	4/2010	Huitema et al.	7,771,396 B2	8/2010	Stefanchik et al.
7,699,868 B2	4/2010	Frank et al.	7,772,720 B2	8/2010	McGee et al.
7,703,653 B2	4/2010	Shah et al.	7,772,725 B2	8/2010	Siman-Tov
7,705,559 B2	4/2010	Powell et al.	7,775,972 B2	8/2010	Brock et al.
7,708,180 B2	5/2010	Murray et al.	7,776,037 B2	8/2010	Odom
7,708,181 B2	5/2010	Cole et al.	7,776,060 B2	8/2010	Mooradian et al.
7,708,182 B2	5/2010	Viola	7,776,065 B2	8/2010	Griffiths et al.
7,708,758 B2	5/2010	Lee et al.	7,778,004 B2	8/2010	Nerheim et al.
7,708,768 B2	5/2010	Danek et al.	7,779,737 B2	8/2010	Newman, Jr. et al.
7,712,182 B2	5/2010	Zeiler et al.	7,780,054 B2	8/2010	Wales
7,713,190 B2	5/2010	Brock et al.	7,780,055 B2	8/2010	Scirica et al.
7,713,542 B2	5/2010	Xu et al.	7,780,309 B2	8/2010	McMillan et al.
7,714,239 B2	5/2010	Smith	7,780,651 B2	8/2010	Madhani et al.
7,714,334 B2	5/2010	Lin	7,780,663 B2	8/2010	Yates et al.
7,717,312 B2	5/2010	Beetel	7,780,685 B2	8/2010	Hunt et al.
7,717,313 B2	5/2010	Criscuolo et al.	7,784,662 B2	8/2010	Wales et al.
7,717,846 B2	5/2010	Zirps et al.	7,784,663 B2	8/2010	Shelton, IV
7,717,873 B2	5/2010	Swick	7,787,256 B2	8/2010	Chan et al.
7,717,915 B2	5/2010	Miyazawa	7,789,283 B2	9/2010	Shah
7,717,926 B2	5/2010	Whitfield et al.	7,789,875 B2	9/2010	Brock et al.
7,718,180 B2	5/2010	Karp	7,789,883 B2	9/2010	Takashino et al.
7,718,556 B2	5/2010	Matsuda et al.	7,789,889 B2	9/2010	Zubik et al.
7,721,930 B2	5/2010	McKenna et al.	7,793,812 B2	9/2010	Moore et al.
7,721,931 B2	5/2010	Shelton, IV et al.	7,794,475 B2	9/2010	Hess et al.
7,721,932 B2	5/2010	Cole et al.	7,798,386 B2	9/2010	Schall et al.
7,721,933 B2	5/2010	Ehrenfels et al.	7,799,039 B2	9/2010	Shelton, IV et al.
7,721,934 B2	5/2010	Shelton, IV et al.	7,799,044 B2	9/2010	Johnston et al.
7,721,936 B2	5/2010	Shalton, IV et al.	7,799,965 B2	9/2010	Patel et al.
7,722,527 B2	5/2010	Bouchier et al.	7,803,151 B2	9/2010	Whitman
7,722,607 B2	5/2010	Dumbauld et al.	7,806,871 B2	10/2010	Li et al.
7,722,610 B2	5/2010	Viola et al.	7,806,891 B2	10/2010	Nowlin et al.
7,725,214 B2	5/2010	Diolaiti	7,810,690 B2	10/2010	Bilotti et al.
7,726,171 B2	6/2010	Langlotz et al.	7,810,691 B2	10/2010	Boyden et al.
7,726,537 B2	6/2010	Olson et al.	7,810,692 B2	10/2010	Hall et al.
7,726,538 B2	6/2010	Holsten et al.	7,810,693 B2	10/2010	Broehl et al.
7,726,539 B2	6/2010	Holsten et al.	7,811,275 B2	10/2010	Birk et al.

US D914,878 S

7,814,816 B2	10/2010	Alberti et al.	7,886,951 B2	2/2011	Hessler
7,815,092 B2	10/2010	Whitman et al.	7,886,952 B2	2/2011	Scirica et al.
7,815,565 B2	10/2010	Stefanchik et al.	7,887,530 B2	2/2011	Zemlok et al.
7,815,662 B2	10/2010	Spivey et al.	7,887,535 B2	2/2011	Lands et al.
7,819,296 B2	10/2010	Hueil et al.	7,887,536 B2	2/2011	Johnson et al.
7,819,297 B2	10/2010	Doll et al.	7,887,563 B2	2/2011	Cummins
7,819,298 B2	10/2010	Hall et al.	7,891,531 B1	2/2011	Ward
7,819,299 B2	10/2010	Shelton, IV et al.	7,891,532 B2	2/2011	Mastri et al.
7,819,799 B2	10/2010	Merril et al.	7,892,200 B2	2/2011	Birk et al.
7,819,884 B2	10/2010	Lee et al.	7,892,245 B2	2/2011	Liddicoat et al.
7,819,885 B2	10/2010	Cooper	7,893,586 B2	2/2011	West et al.
7,819,886 B2	10/2010	Whitfield et al.	7,896,214 B2	3/2011	Farascioni
7,823,592 B2	11/2010	Bettuchi et al.	7,896,215 B2	3/2011	Adams et al.
7,823,760 B2	11/2010	Zemlok et al.	7,896,671 B2	3/2011	Kim et al.
7,824,401 B2	11/2010	Manzo et al.	7,896,869 B2	3/2011	DiSilvestro et al.
7,824,422 B2	11/2010	Benchetrit	7,896,877 B2	3/2011	Hall et al.
7,824,426 B2	11/2010	Racenet et al.	7,896,895 B2	3/2011	Boudreaux et al.
7,828,189 B2	11/2010	Holsten et al.	7,896,897 B2	3/2011	Gresham et al.
7,828,794 B2	11/2010	Sartor	7,896,900 B2	3/2011	Frank et al.
7,828,808 B2	11/2010	Hinman et al.	7,898,198 B2	3/2011	Murphree
7,829,416 B2	11/2010	Kudou et al.	7,900,805 B2	3/2011	Shelton, IV et al.
7,831,292 B2	11/2010	Quaid et al.	7,900,806 B2	3/2011	Chen et al.
7,832,408 B2	11/2010	Shelton, IV et al.	7,901,381 B2	3/2011	Birk et al.
7,832,611 B2	11/2010	Boyden et al.	7,905,380 B2	3/2011	Shelton, IV et al.
7,832,612 B2	11/2010	Baxter et al.	7,905,381 B2	3/2011	Baxter, III et al.
7,833,234 B2	11/2010	Bailly et al.	7,905,881 B2	3/2011	Masuda et al.
7,835,823 B2	11/2010	Sillman et al.	7,905,889 B2	3/2011	Catanese, III et al.
7,836,400 B2	11/2010	May et al.	7,905,890 B2	3/2011	Whitfield et al.
7,837,079 B2	11/2010	Holsten et al.	7,905,902 B2	3/2011	Huitema et al.
7,837,080 B2	11/2010	Schwemberger	7,909,039 B2	3/2011	Hur
7,837,081 B2	11/2010	Holsten et al.	7,909,191 B2	3/2011	Baker et al.
7,837,425 B2	11/2010	Saeki et al.	7,909,220 B2	3/2011	Viola
7,837,685 B2	11/2010	Weinberg et al.	7,909,221 B2	3/2011	Viola et al.
7,837,687 B2	11/2010	Harp	7,909,224 B2	3/2011	Prommersberger
7,837,694 B2	11/2010	Tethrake et al.	7,913,891 B2	3/2011	Doll et al.
7,838,789 B2	11/2010	Stoffers et al.	7,913,893 B2	3/2011	Mastri et al.
7,839,109 B2	11/2010	Carmen, Jr. et al.	7,914,521 B2	3/2011	Wang et al.
7,840,253 B2	11/2010	Tremblay et al.	7,914,543 B2	3/2011	Roth et al.
7,841,503 B2	11/2010	Sonnenschein et al.	7,914,551 B2	3/2011	Ortiz et al.
7,842,025 B2	11/2010	Coleman et al.	7,918,230 B2	4/2011	Whitman et al.
7,842,028 B2	11/2010	Lee	7,918,376 B1	4/2011	Knodel et al.
7,843,158 B2	11/2010	Prisco	7,918,377 B2	4/2011	Measamer et al.
7,845,533 B2	12/2010	Marczyk et al.	7,918,845 B2	4/2011	Saadat et al.
7,845,534 B2	12/2010	Viola et al.	7,918,848 B2	4/2011	Lau et al.
7,845,535 B2	12/2010	Scircia	7,918,861 B2	4/2011	Brock et al.
7,845,536 B2	12/2010	Viola et al.	7,918,867 B2	4/2011	Dana et al.
7,845,537 B2	12/2010	Shelton, IV et al.	7,922,061 B2	4/2011	Shelton, IV et al.
7,845,538 B2	12/2010	Whitman	7,922,063 B2	4/2011	Zemlok et al.
7,846,085 B2	12/2010	Silverman et al.	7,922,743 B2	4/2011	Heinrich et al.
7,846,149 B2	12/2010	Jankowski	7,923,144 B2	4/2011	Kohn et al.
7,846,161 B2	12/2010	Dumbauld et al.	7,926,691 B2	4/2011	Viola et al.
7,848,066 B2	12/2010	Yanagishima	7,926,692 B2	4/2011	Racenet et al.
7,850,623 B2	12/2010	Griffin et al.	7,927,328 B2	4/2011	Orszulak et al.
7,850,642 B2	12/2010	Moll et al.	7,928,281 B2	4/2011	Augustine
7,850,982 B2	12/2010	Stopek et al.	7,930,040 B1	4/2011	Kelsch et al.
7,853,813 B2	12/2010	Lee	7,930,065 B2	4/2011	Larkin et al.
7,854,735 B2	12/2010	Houser et al.	7,931,660 B2	4/2011	Aranyi et al.
7,854,736 B2	12/2010	Ryan	7,931,695 B2	4/2011	Ringeisen
7,857,183 B2	12/2010	Shelton, IV	7,931,877 B2	4/2011	Steffens et al.
7,857,184 B2	12/2010	Viola	7,934,630 B2	5/2011	Shelton, IV et al.
7,857,185 B2	12/2010	Swayze et al.	7,934,631 B2	5/2011	Balbierz et al.
7,857,186 B2	12/2010	Baxter, III et al.	7,934,896 B2	5/2011	Schnier
7,857,813 B2	12/2010	Schmitz et al.	7,935,130 B2	5/2011	Williams
7,861,906 B2	1/2011	Doll et al.	7,935,773 B2	5/2011	Hadba et al.
7,862,502 B2	1/2011	Pool et al.	7,936,142 B2	5/2011	Otsuka et al.
7,862,546 B2	1/2011	Conlon et al.	7,938,307 B2	5/2011	Bettuchi
7,862,579 B2	1/2011	Ortiz et al.	7,939,152 B2	5/2011	Haskin et al.
7,866,525 B2	1/2011	Scirica	7,941,865 B2	5/2011	Seman, Jr. et al.
7,866,527 B2	1/2011	Hall et al.	7,942,303 B2	5/2011	Shah
7,866,528 B2	1/2011	Olson et al.	7,942,890 B2	5/2011	D'Agostino et al.
7,870,989 B2	1/2011	Viola et al.	7,944,175 B2	5/2011	Mori et al.
7,871,418 B2	1/2011	Thompson et al.	7,945,792 B2	5/2011	Cherpantier
7,871,440 B2	1/2011	Schwartz et al.	7,945,798 B2	5/2011	Carlson et al.
7,875,055 B2	1/2011	Cichocki, Jr.	7,946,453 B2	5/2011	Voegele et al.
7,879,063 B2	2/2011	Khosravi	7,947,011 B2	5/2011	Birk et al.
7,879,070 B2	2/2011	Ortiz et al.	7,950,560 B2	5/2011	Zemlok et al.
7,883,461 B2	2/2011	Albrecht et al.	7,950,561 B2	5/2011	Aranyi
7,883,465 B2	2/2011	Donofrio et al.	7,950,562 B2	5/2011	Beardsley et al.
7,883,540 B2	2/2011	Niwa et al.	7,951,071 B2	5/2011	Whitman et al.

US D914,878 S

7,951,166 B2	5/2011	Orban, III et al.	8,025,199 B2	9/2011	Whitman et al.
7,954,682 B2	6/2011	Giordano et al.	8,025,896 B2	9/2011	Malaviya et al.
7,954,684 B2	6/2011	Boudreaux	8,028,882 B2	10/2011	Viola
7,954,685 B2	6/2011	Viola	8,028,883 B2	10/2011	Stopek
7,954,686 B2	6/2011	Baxter, III et al.	8,028,884 B2	10/2011	Sniffin et al.
7,954,687 B2	6/2011	Zemlok et al.	8,028,885 B2	10/2011	Smith et al.
7,954,688 B2	6/2011	Argentine et al.	8,029,510 B2	10/2011	Hoegerle
7,955,253 B2	6/2011	Ewers et al.	8,031,069 B2	10/2011	Cohn et al.
7,955,257 B2	6/2011	Frasier et al.	8,033,438 B2	10/2011	Scirica
7,955,322 B2	6/2011	Devengenzo et al.	8,033,439 B2	10/2011	Racenet et al.
7,955,327 B2	6/2011	Sartor et al.	8,033,440 B2	10/2011	Wenchell et al.
7,955,380 B2	6/2011	Chu et al.	8,033,442 B2	10/2011	Racenet et al.
7,959,050 B2	6/2011	Smith et al.	8,034,077 B2	10/2011	Smith et al.
7,959,051 B2	6/2011	Smith et al.	8,034,337 B2	10/2011	Simard
7,959,052 B2	6/2011	Sonnenschein et al.	8,034,363 B2	10/2011	Li et al.
7,963,432 B2	6/2011	Knodel et al.	8,035,487 B2	10/2011	Malackowski
7,963,433 B2	6/2011	Whitman et al.	8,037,591 B2	10/2011	Spivey et al.
7,963,913 B2	6/2011	Devengenzo et al.	8,038,045 B2	10/2011	Bettuchi et al.
7,963,963 B2	6/2011	Francischelli et al.	8,038,046 B2	10/2011	Smith et al.
7,963,964 B2	6/2011	Santilli et al.	8,038,686 B2	10/2011	Huitema et al.
7,964,206 B2	6/2011	Suokas et al.	8,043,207 B2	10/2011	Adams
7,966,236 B2	6/2011	Noriega et al.	8,043,328 B2	10/2011	Hahnen et al.
7,966,269 B2	6/2011	Bauer et al.	8,044,536 B2	10/2011	Nguyen et al.
7,966,799 B2	6/2011	Morgan et al.	8,044,604 B2	10/2011	Hagino et al.
7,967,178 B2	6/2011	Scirica et al.	8,047,236 B2	11/2011	Perry
7,967,179 B2	6/2011	Olson et al.	8,048,503 B2	11/2011	Farnsworth et al.
7,967,180 B2	6/2011	Scirica	8,052,636 B2	11/2011	Moll et al.
7,967,181 B2	6/2011	Viola et al.	8,056,787 B2	11/2011	Boudreaux et al.
7,967,791 B2	6/2011	Franer et al.	8,056,788 B2	11/2011	Mastri et al.
7,967,839 B2	6/2011	Flock et al.	8,056,789 B1	11/2011	White et al.
7,972,298 B2	7/2011	Wallace et al.	8,057,508 B2	11/2011	Shelton, IV
7,972,315 B2	7/2011	Birk et al.	8,058,771 B2	11/2011	Giordano et al.
7,976,213 B2	7/2011	Bertolotti et al.	8,060,250 B2	11/2011	Reiland et al.
7,976,563 B2	7/2011	Summerer	8,061,014 B2	11/2011	Smith et al.
7,979,137 B2	7/2011	Tracey et al.	8,061,576 B2	11/2011	Cappola
7,980,443 B2	7/2011	Scheib et al.	8,062,236 B2	11/2011	Soltz
7,981,102 B2	7/2011	Patel et al.	8,062,306 B2	11/2011	Nobis et al.
7,981,132 B2	7/2011	Dubrul et al.	8,062,330 B2	11/2011	Prommersberger et al.
7,987,405 B2	7/2011	Turner et al.	8,063,619 B2	11/2011	Zhu et al.
7,988,015 B2	8/2011	Mason, II et al.	8,066,158 B2	11/2011	Vogel et al.
7,988,026 B2	8/2011	Knodel et al.	8,066,166 B2	11/2011	Demmy et al.
7,988,027 B2	8/2011	Olson et al.	8,066,167 B2	11/2011	Measamer et al.
7,988,028 B2	8/2011	Farascioni et al.	8,066,168 B2	11/2011	Vidal et al.
7,988,779 B2	8/2011	Disalvo et al.	8,066,720 B2	11/2011	Knodel et al.
7,992,757 B2	8/2011	Wheeler et al.	D650,074 S	12/2011	Hunt et al.
7,993,360 B2	8/2011	Hacker et al.	D650,789 S	12/2011	Arnold
7,994,670 B2	8/2011	Ji	8,070,033 B2	12/2011	Milliman et al.
7,997,054 B2	8/2011	Bertsch et al.	8,070,034 B1	12/2011	Knodel
7,997,468 B2	8/2011	Farascioni	8,070,035 B2	12/2011	Holsten et al.
7,997,469 B2	8/2011	Olson et al.	8,070,743 B2	12/2011	Kagan et al.
8,002,696 B2	8/2011	Suzuki	8,074,858 B2	12/2011	Marczyk
8,002,784 B2	8/2011	Jinno et al.	8,074,859 B2	12/2011	Kostrzewski
8,002,785 B2	8/2011	Weiss et al.	8,074,861 B2	12/2011	Ehrenfels et al.
8,002,795 B2	8/2011	Beetel	8,075,476 B2	12/2011	Vargas
8,006,365 B2	8/2011	Levin et al.	8,075,571 B2	12/2011	Vitali et al.
8,006,885 B2	8/2011	Marczyk	8,079,950 B2	12/2011	Stern et al.
8,006,889 B2	8/2011	Adams et al.	8,079,989 B2	12/2011	Birk et al.
8,007,370 B2	8/2011	Hirsch et al.	8,080,004 B2	12/2011	Downey et al.
8,007,465 B2	8/2011	Birk et al.	8,083,118 B2	12/2011	Milliman et al.
8,007,479 B2	8/2011	Birk et al.	8,083,119 B2	12/2011	Prommersberger
8,007,511 B2	8/2011	Brock et al.	8,083,120 B2	12/2011	Shelton, IV et al.
8,007,513 B2	8/2011	Nalagatla et al.	8,084,001 B2	12/2011	Burns et al.
8,008,598 B2	8/2011	Whitman et al.	8,084,969 B2	12/2011	David et al.
8,010,180 B2	8/2011	Quaid et al.	8,085,013 B2	12/2011	Wei et al.
8,011,550 B2	9/2011	Aranyi et al.	8,087,562 B1	1/2012	Manoux et al.
8,011,551 B2	9/2011	Marczyk et al.	8,087,563 B2	1/2012	Milliman et al.
8,011,553 B2	9/2011	Mastri et al.	8,089,509 B2	1/2012	Chatenever et al.
8,011,555 B2	9/2011	Tarinelli et al.	8,091,753 B2	1/2012	Viola
8,012,170 B2	9/2011	Whitman et al.	8,091,756 B2	1/2012	Viola
8,016,176 B2	9/2011	Kasvikis et al.	8,092,443 B2	1/2012	Bischoff
8,016,177 B2	9/2011	Bettuchi et al.	8,092,932 B2	1/2012	Phillips et al.
8,016,178 B2	9/2011	Olson et al.	8,093,572 B2	1/2012	Kuduvalli
8,016,849 B2	9/2011	Wenchell	8,096,458 B2	1/2012	Hessler
8,016,855 B2	9/2011	Whitman et al.	8,096,459 B2	1/2012	Ortiz et al.
8,016,858 B2	9/2011	Whitman	8,097,017 B2	1/2012	Viola
8,016,881 B2	9/2011	Furst	8,100,310 B2	1/2012	Zemlok
8,020,742 B2	9/2011	Marczyk	8,100,824 B2	1/2012	Hegeman et al.
8,020,743 B2	9/2011	Shelton, IV	8,100,872 B2	1/2012	Patel
8,021,375 B2	9/2011	Aldrich et al.	8,102,138 B2	1/2012	Sekine et al.

US D914,878 S

8,102,278 B2	1/2012	Deck et al.	8,181,840 B2	5/2012	Milliman
8,105,320 B2	1/2012	Manzo	8,182,422 B2	5/2012	Bayer et al.
8,105,350 B2	1/2012	Lee et al.	8,182,444 B2	5/2012	Uber, III et al.
8,107,925 B2	1/2012	Natsuno et al.	8,183,807 B2	5/2012	Tsai et al.
8,108,033 B2	1/2012	Drew et al.	8,186,555 B2	5/2012	Shelton, IV et al.
8,108,072 B2	1/2012	Zhao et al.	8,186,556 B2	5/2012	Viola
8,109,426 B2	2/2012	Milliman et al.	8,186,558 B2	5/2012	Sapienza
8,110,208 B1	2/2012	Hen	8,186,560 B2	5/2012	Hess et al.
8,113,405 B2	2/2012	Milliman	8,190,238 B2	5/2012	Moll et al.
8,113,407 B2	2/2012	Holsten et al.	8,191,752 B2	6/2012	Scirica
8,113,408 B2	2/2012	Wenchell et al.	8,192,350 B2	6/2012	Ortiz et al.
8,113,410 B2	2/2012	Hall et al.	8,192,460 B2	6/2012	Orban, III et al.
8,114,017 B2	2/2012	Bacher	8,192,651 B2	6/2012	Young et al.
8,114,100 B2	2/2012	Smith et al.	8,193,129 B2	6/2012	Tagawa et al.
8,118,206 B2	2/2012	Zand et al.	8,196,795 B2	6/2012	Moore et al.
8,118,207 B2	2/2012	Racenet et al.	8,196,796 B2	6/2012	Shelton, IV et al.
8,120,301 B2	2/2012	Goldberg et al.	8,197,501 B2	6/2012	Shadeck et al.
8,122,128 B2	2/2012	Burke, II et al.	8,197,502 B2	6/2012	Smith et al.
8,123,103 B2	2/2012	Milliman	8,197,837 B2	6/2012	Jamiolkowski et al.
8,123,523 B2	2/2012	Carron et al.	8,201,720 B2	6/2012	Hessler
8,123,766 B2	2/2012	Bauman et al.	8,201,721 B2	6/2012	Zemlok et al.
8,123,767 B2	2/2012	Bauman et al.	8,202,549 B2	6/2012	Stucky et al.
8,125,168 B2	2/2012	Johnson et al.	8,205,779 B2	6/2012	Ma et al.
8,127,975 B2	3/2012	Olson et al.	8,205,780 B2	6/2012	Sorrentino et al.
8,127,976 B2	3/2012	Scirica et al.	8,205,781 B2	6/2012	Baxter, III et al.
8,128,624 B2	3/2012	Couture et al.	8,210,411 B2	7/2012	Yates et al.
8,128,643 B2	3/2012	Aranyi et al.	8,210,414 B2	7/2012	Bettuchi et al.
8,128,645 B2	3/2012	Sonnenschein et al.	8,210,415 B2	7/2012	Ward
8,128,662 B2	3/2012	Altarac et al.	8,210,416 B2	7/2012	Milliman et al.
8,132,703 B2	3/2012	Milliman et al.	8,210,721 B2	7/2012	Chen et al.
8,132,705 B2	3/2012	Viola et al.	8,211,125 B2	7/2012	Spivey
8,132,706 B2	3/2012	Marczyk et al.	8,214,019 B2	7/2012	Govari et al.
8,133,500 B2	3/2012	Ringeisen et al.	8,215,531 B2	7/2012	Shelton, IV et al.
8,134,306 B2	3/2012	Drader et al.	8,215,532 B2	7/2012	Marczyk
8,136,711 B2	3/2012	Beardsley et al.	8,215,533 B2	7/2012	Viola et al.
8,136,712 B2	3/2012	Zingman	8,220,468 B2	7/2012	Cooper et al.
8,136,713 B2	3/2012	Hathaway et al.	8,220,688 B2	7/2012	Laurent et al.
8,137,339 B2	3/2012	Jinno et al.	8,220,690 B2	7/2012	Hess et al.
8,140,417 B2	3/2012	Shibata	8,221,402 B2	7/2012	Francischelli et al.
8,141,762 B2	3/2012	Bedi et al.	8,221,424 B2	7/2012	Cha
8,141,763 B2	3/2012	Milliman	8,221,433 B2	7/2012	Lozier et al.
8,142,200 B2	3/2012	Crunkilton et al.	8,225,799 B2	7/2012	Bettuchi
8,142,425 B2	3/2012	Eggers	8,225,979 B2	7/2012	Farascioni et al.
8,142,461 B2	3/2012	Houser et al.	8,226,553 B2	7/2012	Shelton, IV et al.
8,142,515 B2	3/2012	Therin et al.	8,226,635 B2	7/2012	Petrie et al.
8,143,520 B2	3/2012	Cutler	8,226,675 B2	7/2012	Houser et al.
8,146,790 B2	4/2012	Milliman	8,226,715 B2	7/2012	Hwang et al.
8,147,421 B2	4/2012	Farquhar et al.	8,227,946 B2	7/2012	Kim
8,147,456 B2	4/2012	Fisher et al.	8,228,020 B2	7/2012	Shin et al.
8,147,485 B2	4/2012	Wham et al.	8,228,048 B2	7/2012	Spencer
8,152,041 B2	4/2012	Kostrzewski	8,229,549 B2	7/2012	Whitman et al.
8,152,756 B2	4/2012	Webster et al.	8,231,040 B2	7/2012	Zemlok et al.
8,154,239 B2	4/2012	Katsuki et al.	8,231,042 B2	7/2012	Hessler et al.
8,157,145 B2	4/2012	Shelton, IV et al.	8,231,043 B2	7/2012	Tarinelli et al.
8,157,148 B2	4/2012	Scirica	8,235,272 B2	8/2012	Nicholas et al.
8,157,151 B2	4/2012	Ingmanson et al.	8,236,010 B2	8/2012	Ortiz et al.
8,157,152 B2	4/2012	Holsten et al.	8,236,011 B2	8/2012	Harris et al.
8,157,153 B2	4/2012	Shelton, IV et al.	8,236,020 B2	8/2012	Smith et al.
8,157,793 B2	4/2012	Omori et al.	8,237,388 B2	8/2012	Jinno et al.
8,161,977 B2	4/2012	Shelton, IV et al.	8,240,537 B2	8/2012	Marczyk
8,162,138 B2	4/2012	Bettenhausen et al.	8,241,271 B2	8/2012	Millman et al.
8,162,197 B2	4/2012	Mastri et al.	8,241,284 B2	8/2012	Dycus et al.
8,162,668 B2	4/2012	Toly	8,241,308 B2	8/2012	Kortenbach et al.
8,162,933 B2	4/2012	Francischelli et al.	8,241,322 B2	8/2012	Whitman et al.
8,162,965 B2	4/2012	Reschke et al.	8,245,594 B2	8/2012	Rogers et al.
8,167,185 B2	5/2012	Shelton, IV et al.	8,245,898 B2	8/2012	Smith et al.
8,167,622 B2	5/2012	Zhou	8,245,899 B2	8/2012	Swensgard et al.
8,167,895 B2	5/2012	D'Agostino et al.	8,245,900 B2	8/2012	Scirica
8,167,898 B1	5/2012	Schaller et al.	8,245,901 B2	8/2012	Stopek
8,170,241 B2	5/2012	Roe et al.	8,246,608 B2	8/2012	Omori et al.
8,172,004 B2	5/2012	Ho	8,246,637 B2	8/2012	Viola et al.
8,172,120 B2	5/2012	Boyden et al.	8,252,009 B2	8/2012	Weller et al.
8,172,122 B2	5/2012	Kasvikis et al.	8,256,654 B2	9/2012	Bettuchi et al.
8,172,124 B2	5/2012	Shelton, IV et al.	8,256,655 B2	9/2012	Sniffin et al.
8,177,776 B2	5/2012	Humayun et al.	8,256,656 B2	9/2012	Milliman et al.
8,177,797 B2	5/2012	Shimoji et al.	8,257,251 B2	9/2012	Shelton, IV et al.
8,179,705 B2	5/2012	Chapuis	8,257,356 B2	9/2012	Bleich et al.
8,180,458 B2	5/2012	Kane et al.	8,257,386 B2	9/2012	Lee et al.
8,181,839 B2	5/2012	Beetel	8,257,391 B2	9/2012	Orban, III et al.

US D914,878 S

Page 22

8,257,634 B2	9/2012	Scirica	8,324,585 B2	12/2012	McBroom et al.
8,258,745 B2	9/2012	Smith et al.	8,328,061 B2	12/2012	Kasvikis
8,261,958 B1	9/2012	Knodel	8,328,062 B2	12/2012	Viola
8,262,560 B2	9/2012	Whitman	8,328,063 B2	12/2012	Milliman et al.
8,262,655 B2	9/2012	Ghabrial et al.	8,328,064 B2	12/2012	Racenet et al.
8,266,232 B2	9/2012	Piper et al.	8,328,802 B2	12/2012	Deville et al.
8,267,300 B2	9/2012	Boudreaux	8,328,823 B2	12/2012	Aranyi et al.
8,267,849 B2	9/2012	Wazer et al.	8,333,313 B2	12/2012	Boudreaux et al.
8,267,924 B2	9/2012	Zemlok et al.	8,333,691 B2	12/2012	Schaaf
8,267,946 B2	9/2012	Whitfield et al.	8,333,764 B2	12/2012	Francischelli et al.
8,267,951 B2	9/2012	Whayne et al.	8,333,779 B2	12/2012	Smith et al.
8,268,344 B2	9/2012	Ma et al.	8,334,468 B2	12/2012	Palmer et al.
8,269,121 B2	9/2012	Smith	8,336,753 B2	12/2012	Olson et al.
8,272,553 B2	9/2012	Mastri et al.	8,336,754 B2	12/2012	Cappola et al.
8,272,554 B2	9/2012	Whitman et al.	8,342,377 B2	1/2013	Milliman et al.
8,272,918 B2	9/2012	Lam	8,342,378 B2	1/2013	Marczyk et al.
8,273,404 B2	9/2012	Dave et al.	8,342,379 B2	1/2013	Whitman et al.
8,276,594 B2	10/2012	Shah	8,342,380 B2	1/2013	Viola
8,276,801 B2	10/2012	Zemlok et al.	8,343,150 B2	1/2013	Artale
8,276,802 B2	10/2012	Kostrzewski	8,347,978 B2	1/2013	Forster et al.
8,277,473 B2	10/2012	Sunaoshi et al.	8,348,118 B2	1/2013	Segura
8,281,446 B2	10/2012	Moskovich	8,348,123 B2	1/2013	Scirica et al.
8,281,973 B2	10/2012	Wenchell et al.	8,348,124 B2	1/2013	Scirica
8,281,974 B2	10/2012	Hessler et al.	8,348,125 B2	1/2013	Viola et al.
8,282,654 B2	10/2012	Ferrari et al.	8,348,126 B2	1/2013	Olson et al.
8,285,367 B2	10/2012	Hyde et al.	8,348,127 B2	1/2013	Marczyk
8,286,723 B2	10/2012	Puzio et al.	8,348,129 B2	1/2013	Bedi et al.
8,286,845 B2	10/2012	Perry et al.	8,348,130 B2	1/2013	Shah et al.
8,286,846 B2	10/2012	Smith et al.	8,348,131 B2	1/2013	Omaits et al.
8,286,847 B2	10/2012	Taylor	8,348,837 B2	1/2013	Wenchell
8,287,487 B2	10/2012	Estes	8,348,959 B2	1/2013	Wolford et al.
8,287,522 B2	10/2012	Moses et al.	8,348,972 B2	1/2013	Soltz et al.
8,287,561 B2	10/2012	Nunez et al.	8,349,987 B2	1/2013	Kapiamba et al.
8,288,984 B2	10/2012	Yang	8,352,004 B2	1/2013	Mannheimer et al.
8,289,403 B2	10/2012	Dobashi et al.	8,353,437 B2	1/2013	Boudreaux
8,290,883 B2	10/2012	Takeuchi et al.	8,353,438 B2	1/2013	Baxter, III et al.
8,292,147 B2	10/2012	Viola	8,353,439 B2	1/2013	Baxter, III et al.
8,292,148 B2	10/2012	Viola	8,356,740 B1	1/2013	Knodel
8,292,150 B2	10/2012	Bryant	8,357,144 B2	1/2013	Whitman et al.
8,292,151 B2	10/2012	Viola	8,357,158 B2	1/2013	McKenna et al.
8,292,152 B2	10/2012	Milliman et al.	8,357,161 B2	1/2013	Mueller
8,292,155 B2	10/2012	Shelton, IV et al.	8,359,174 B2	1/2013	Nakashima et al.
8,292,157 B2	10/2012	Smith et al.	8,360,296 B2	1/2013	Zingman
8,292,158 B2	10/2012	Sapienza	8,360,297 B2	1/2013	Shelton, IV et al.
8,292,801 B2	10/2012	Dejima et al.	8,360,298 B2	1/2013	Farascioni et al.
8,292,888 B2	10/2012	Whitman	8,360,299 B2	1/2013	Zemlok et al.
8,292,906 B2	10/2012	Taylor et al.	8,361,501 B2	1/2013	DiTizio et al.
8,294,399 B2	10/2012	Suzuki et al.	D676,866 S	2/2013	Chaudhri
8,298,161 B2	10/2012	Vargas	8,365,972 B2	2/2013	Aranyi et al.
8,298,189 B2	10/2012	Fisher et al.	8,365,973 B1	2/2013	White et al.
8,298,233 B2	10/2012	Mueller	8,365,975 B1	2/2013	Manoux et al.
8,298,677 B2	10/2012	Wiesner et al.	8,365,976 B2	2/2013	Hess et al.
8,302,323 B2	11/2012	Fortier et al.	8,366,559 B2	2/2013	Papenfuss et al.
8,303,621 B2	11/2012	Miyamoto et al.	8,366,719 B2	2/2013	Markey et al.
8,308,040 B2	11/2012	Huang et al.	8,366,787 B2	2/2013	Brown et al.
8,308,041 B2	11/2012	Kostrzewski	8,368,327 B2	2/2013	Benning et al.
8,308,042 B2	11/2012	Aranyi	8,369,056 B2	2/2013	Senriuchi et al.
8,308,043 B2	11/2012	Bindra et al.	8,371,393 B2	2/2013	Higuchi et al.
8,308,046 B2	11/2012	Prommersberger	8,371,491 B2	2/2013	Huitema et al.
8,308,659 B2	11/2012	Scheibe et al.	8,371,492 B2	2/2013	Aranyi et al.
8,308,725 B2	11/2012	Bell et al.	8,371,493 B2	2/2013	Aranyi et al.
8,310,188 B2	11/2012	Nakai	8,371,494 B2	2/2013	Racenet et al.
8,313,496 B2	11/2012	Sauer et al.	8,372,094 B2	2/2013	Bettuchi et al.
8,313,499 B2	11/2012	Magnusson et al.	8,374,723 B2	2/2013	Zhao et al.
8,313,509 B2	11/2012	Kostrzewski	8,376,865 B2	2/2013	Forster et al.
8,317,070 B2	11/2012	Hueil et al.	8,377,029 B2	2/2013	Nagao et al.
8,317,071 B1	11/2012	Knodel	8,377,044 B2	2/2013	Coe et al.
8,317,074 B2	11/2012	Ortiz et al.	8,381,828 B2	2/2013	Whitman et al.
8,317,437 B2	11/2012	Merkley et al.	8,382,773 B2	2/2013	Whitfield et al.
8,317,744 B2	11/2012	Kirschenman	8,382,790 B2	2/2013	Uenohara et al.
8,317,790 B2	11/2012	Bell et al.	D677,273 S	3/2013	Randall et al.
8,319,002 B2	11/2012	Daniels et al.	8,387,848 B2	3/2013	Johnson et al.
D672,784 S	12/2012	Clanton et al.	8,388,633 B2	3/2013	Rousseau et al.
8,322,455 B2	12/2012	Shelton, IV et al.	8,389,588 B2	3/2013	Ringeisen et al.
8,322,589 B2	12/2012	Boudreaux	8,393,513 B2	3/2013	Jankowski
8,322,590 B2	12/2012	Patel et al.	8,393,514 B2	3/2013	Shelton, IV et al.
8,322,901 B2	12/2012	Michelotti	8,393,516 B2	3/2013	Kostrzewski
8,323,271 B2	12/2012	Humayun et al.	8,397,832 B2	3/2013	Blickle et al.
8,323,789 B2	12/2012	Rozhin et al.	8,397,971 B2	3/2013	Yates et al.

US D914,878 S

8,397,972 B2	3/2013	Kostrzewski	8,465,475 B2	6/2013	Isbell, Jr.
8,397,973 B1	3/2013	Hausen	8,465,502 B2	6/2013	Zergiebel
8,398,633 B2	3/2013	Mueller	8,465,515 B2	6/2013	Drew et al.
8,398,669 B2	3/2013	Kim	8,469,254 B2	6/2013	Czernik et al.
8,398,673 B2	3/2013	Hinchliffe et al.	8,469,946 B2	6/2013	Sugita
8,398,674 B2	3/2013	Prestel	8,469,973 B2	6/2013	Meade et al.
8,400,851 B2	3/2013	Byun	8,470,355 B2	6/2013	Skalla et al.
8,403,138 B2	3/2013	Weisshaupt et al.	D686,240 S	7/2013	Lin
8,403,195 B2	3/2013	Beardsley et al.	D686,244 S	7/2013	Moriya et al.
8,403,196 B2	3/2013	Beardsley et al.	8,474,677 B2	7/2013	Woodard, Jr. et al.
8,403,198 B2	3/2013	Sorrentino et al.	8,475,453 B2	7/2013	Marczyk et al.
8,403,832 B2	3/2013	Cunningham et al.	8,475,454 B1	7/2013	Alshemari
8,403,926 B2	3/2013	Nobis et al.	8,475,474 B2	7/2013	Bombard et al.
8,403,945 B2	3/2013	Whitfield et al.	8,479,968 B2	7/2013	Hodgkinson et al.
8,403,946 B2	3/2013	Whitfield et al.	8,479,969 B2	7/2013	Shelton, IV
8,403,950 B2	3/2013	Palmer et al.	8,480,703 B2	7/2013	Nicholas et al.
D680,646 S	4/2013	Hunt et al.	8,483,509 B2	7/2013	Matsuzaka
8,408,439 B2	4/2013	Huang et al.	8,485,412 B2	7/2013	Shelton, IV et al.
8,408,442 B2	4/2013	Racenet et al.	8,485,413 B2	7/2013	Scheib et al.
8,409,079 B2	4/2013	Okamoto et al.	8,485,970 B2	7/2013	Widenhouse et al.
8,409,174 B2	4/2013	Omori	8,487,199 B2	7/2013	Palmer et al.
8,409,175 B2	4/2013	Lee et al.	8,487,487 B2	7/2013	Dietz et al.
8,409,211 B2	4/2013	Baroud	8,490,851 B2	7/2013	Blier et al.
8,409,222 B2	4/2013	Whitfield et al.	8,490,852 B2	7/2013	Viola
8,409,223 B2	4/2013	Sorrentino et al.	8,490,853 B2	7/2013	Criscuolo et al.
8,411,500 B2	4/2013	Gapihan et al.	8,491,581 B2	7/2013	Deville et al.
8,413,661 B2	4/2013	Rousseau et al.	8,491,603 B2	7/2013	Yeung et al.
8,413,870 B2	4/2013	Pastorelli et al.	8,496,153 B2	7/2013	Demmy et al.
8,413,871 B2	4/2013	Racenet et al.	8,496,154 B2	7/2013	Marczyk et al.
8,413,872 B2	4/2013	Patel	8,496,156 B2	7/2013	Sniffin et al.
8,414,469 B2	4/2013	Diolaiti	8,496,683 B2	7/2013	Prommersberger et al.
8,414,577 B2	4/2013	Boudreaux et al.	8,498,691 B2	7/2013	Moll et al.
8,414,598 B2	4/2013	Brock et al.	8,499,673 B2	8/2013	Keller
8,418,073 B2	4/2013	Mohr et al.	8,499,992 B2	8/2013	Whitman et al.
8,418,906 B2	4/2013	Farascioni et al.	8,499,993 B2	8/2013	Shelton, IV et al.
8,418,907 B2	4/2013	Johnson et al.	8,500,721 B2	8/2013	Jinno
8,418,908 B1	4/2013	Beardsley	8,500,762 B2	8/2013	Sholev et al.
8,418,909 B2	4/2013	Kostrzewski	8,502,091 B2	8/2013	Palmer et al.
8,419,635 B2	4/2013	Shelton, IV et al.	8,505,799 B2	8/2013	Viola et al.
8,419,717 B2	4/2013	Diolaiti et al.	8,505,801 B2	8/2013	Ehrenfels et al.
8,419,747 B2	4/2013	Hinman et al.	8,506,555 B2	8/2013	Ruiz Morales
8,419,754 B2	4/2013	Laby et al.	8,506,557 B2	8/2013	Zemlok et al.
8,419,755 B2	4/2013	Deem et al.	8,506,580 B2	8/2013	Zergiebel et al.
8,423,182 B2	4/2013	Robinson et al.	8,506,581 B2	8/2013	Wingardner, III et al.
8,424,737 B2	4/2013	Scirica	8,511,308 B2	8/2013	Hecox et al.
8,424,739 B2	4/2013	Racenet et al.	8,512,359 B2	8/2013	Whitman et al.
8,424,740 B2	4/2013	Shelton, IV et al.	8,512,402 B2	8/2013	Marczyk et al.
8,424,741 B2	4/2013	McGuckin, Jr. et al.	8,517,239 B2	8/2013	Scheib et al.
8,425,600 B2	4/2013	Maxwell	8,517,241 B2	8/2013	Nicholas et al.
8,427,430 B2	4/2013	Lee et al.	8,517,243 B2	8/2013	Giordano et al.
8,430,292 B2	4/2013	Patel et al.	8,517,244 B2	8/2013	Shelton, IV et al.
8,430,892 B2	4/2013	Bindra et al.	8,518,024 B2	8/2013	Williams et al.
8,430,898 B2	4/2013	Wiener et al.	8,521,273 B2	8/2013	Kliman
8,435,257 B2	5/2013	Smith et al.	8,523,042 B2	9/2013	Masiakos et al.
8,439,246 B1	5/2013	Knodel	8,523,043 B2	9/2013	Ullrich et al.
8,444,036 B2	5/2013	Shelton, IV	8,523,787 B2	9/2013	Ludwin et al.
8,444,037 B2	5/2013	Nicholas et al.	8,523,881 B2	9/2013	Cabiri et al.
8,444,549 B2	5/2013	Viola et al.	8,523,900 B2	9/2013	Jinno et al.
8,449,536 B2	5/2013	Selig	8,529,588 B2	9/2013	Ahlberg et al.
8,449,560 B2	5/2013	Roth et al.	8,529,600 B2	9/2013	Woodard, Jr. et al.
8,453,904 B2	6/2013	Eskaros et al.	8,529,819 B2	9/2013	Ostapoff et al.
8,453,906 B2	6/2013	Huang et al.	8,532,747 B2	9/2013	Nock et al.
8,453,907 B2	6/2013	Laurent et al.	8,534,527 B2	9/2013	Brendel et al.
8,453,908 B2	6/2013	Bedi et al.	8,534,528 B2	9/2013	Shelton, IV
8,453,912 B2	6/2013	Mastri et al.	8,535,304 B2	9/2013	Sklar et al.
8,453,914 B2	6/2013	Laurent et al.	8,535,340 B2	9/2013	Allen
8,454,495 B2	6/2013	Kawano et al.	8,539,866 B2	9/2013	Nayak et al.
8,454,551 B2	6/2013	Allen et al.	8,540,128 B2	9/2013	Shelton, IV et al.
8,454,628 B2	6/2013	Smith et al.	8,540,129 B2	9/2013	Baxter, III et al.
8,454,640 B2	6/2013	Johnston et al.	8,540,130 B2	9/2013	Moore et al.
8,457,757 B2	6/2013	Cauller et al.	8,540,131 B2	9/2013	Swayze
8,459,520 B2	6/2013	Giordano et al.	8,540,133 B2	9/2013	Bedi et al.
8,459,521 B2	6/2013	Zemlok et al.	8,540,646 B2	9/2013	Mendez-Coll
8,459,524 B2	6/2013	Pribanic et al.	8,540,733 B2	9/2013	Whitman et al.
8,459,525 B2	6/2013	Yates et al.	8,540,735 B2	9/2013	Mitelberg et al.
8,464,922 B2	6/2013	Marczyk	8,550,984 B2	10/2013	Takemoto
8,464,923 B2	6/2013	Shelton, IV	8,551,076 B2	10/2013	Duval et al.
8,464,924 B2	6/2013	Gresham et al.	8,555,660 B2	10/2013	Takenaka et al.
8,464,925 B2	6/2013	Hull et al.	8,556,151 B2	10/2013	Viola

US D914,878 S

Page 24

8,556,918 B2	10/2013	Bauman et al.	8,652,155 B2	2/2014	Houser et al.
8,556,935 B1	10/2013	Knodel et al.	8,657,174 B2	2/2014	Yates et al.
8,560,147 B2	10/2013	Taylor et al.	8,657,175 B2	2/2014	Sonnenschein et al.
8,561,617 B2	10/2013	Lindh et al.	8,657,176 B2	2/2014	Shelton, IV et al.
8,561,870 B2	10/2013	Baxter, III et al.	8,657,177 B2	2/2014	Scirica et al.
8,561,871 B2	10/2013	Rajappa et al.	8,657,178 B2	2/2014	Hueil et al.
8,561,873 B2	10/2013	Ingmanson et al.	8,657,482 B2	2/2014	Malackowski et al.
8,562,592 B2	10/2013	Conlon et al.	8,657,808 B2	2/2014	McPherson et al.
8,562,598 B2	10/2013	Falkenstein et al.	8,657,814 B2	2/2014	Werneth et al.
8,567,656 B2	10/2013	Shelton, IV et al.	8,657,821 B2	2/2014	Palermo
8,568,416 B2	10/2013	Schmitz et al.	D701,238 S	3/2014	Lai et al.
8,568,425 B2	10/2013	Ross et al.	8,662,370 B2	3/2014	Takei
D692,916 S	11/2013	Granchi et al.	8,663,106 B2	3/2014	Stivoric et al.
8,573,459 B2	11/2013	Smith et al.	8,663,192 B2	3/2014	Hester et al.
8,573,461 B2	11/2013	Shelton, IV et al.	8,663,245 B2	3/2014	Francischelli et al.
8,573,462 B2	11/2013	Smith et al.	8,663,262 B2	3/2014	Smith et al.
8,573,465 B2	11/2013	Shelton, IV	8,663,270 B2	3/2014	Donnigan et al.
8,574,199 B2	11/2013	von Bulow et al.	8,664,792 B2	3/2014	Rebsdorf
8,574,263 B2	11/2013	Mueller	8,668,129 B2	3/2014	Olson
8,575,880 B2	11/2013	Grantz	8,668,130 B2	3/2014	Hess et al.
8,575,895 B2	11/2013	Garrastacho et al.	8,672,206 B2	3/2014	Aranyi et al.
8,579,176 B2	11/2013	Smith et al.	8,672,207 B2	3/2014	Shelton, IV et al.
8,579,178 B2	11/2013	Holsten et al.	8,672,208 B2	3/2014	Hess et al.
8,579,897 B2	11/2013	Vakharia et al.	8,672,922 B2	3/2014	Loh et al.
8,579,937 B2	11/2013	Gresham	8,672,935 B2	3/2014	Okada et al.
8,584,919 B2	11/2013	Hueil et al.	8,672,951 B2	3/2014	Smith et al.
8,584,920 B2	11/2013	Hodgkinson	8,673,210 B2	3/2014	Deshays
8,584,921 B2	11/2013	Scirica	8,675,820 B2	3/2014	Baic et al.
8,585,583 B2	11/2013	Sakaguchi et al.	8,678,263 B2	3/2014	Viola
8,585,721 B2	11/2013	Kirsch	8,678,994 B2	3/2014	Sonnenschein et al.
8,590,760 B2	11/2013	Cummins et al.	8,679,093 B2	3/2014	Farra
8,590,762 B2	11/2013	Hess et al.	8,679,098 B2	3/2014	Hart
8,590,764 B2	11/2013	Hartwick et al.	8,679,137 B2	3/2014	Bauman et al.
8,596,515 B2	12/2013	Okoniewski	8,679,154 B2	3/2014	Smith et al.
8,597,745 B2	12/2013	Farnsworth et al.	8,679,156 B2	3/2014	Smith et al.
8,599,450 B2	12/2013	Kubo et al.	8,679,454 B2	3/2014	Guire et al.
8,602,125 B2	12/2013	King	8,684,248 B2	4/2014	Milliman
8,602,287 B2	12/2013	Yates et al.	8,684,249 B2	4/2014	Racenet et al.
8,602,288 B2	12/2013	Shelton, IV et al.	8,684,250 B2	4/2014	Bettuchi et al.
8,603,077 B2	12/2013	Cooper et al.	8,684,253 B2	4/2014	Giordano et al.
8,603,089 B2	12/2013	Viola	8,684,962 B2	4/2014	Kirschenman et al.
8,603,110 B2	12/2013	Maruyama et al.	8,685,004 B2	4/2014	Zemlock et al.
8,603,135 B2	12/2013	Mueller	8,685,020 B2	4/2014	Weizman et al.
8,608,043 B2	12/2013	Scirica	8,690,893 B2	4/2014	Deitch et al.
8,608,044 B2	12/2013	Hueil et al.	8,695,866 B2	4/2014	Leimbach et al.
8,608,045 B2	12/2013	Smith et al.	8,696,665 B2	4/2014	Hunt et al.
8,608,046 B2	12/2013	Laurent et al.	8,701,958 B2	4/2014	Shelton, IV et al.
8,608,745 B2	12/2013	Guzman et al.	8,701,959 B2	4/2014	Shah
8,613,383 B2	12/2013	Beckman et al.	8,706,316 B1	4/2014	Hoevenaer
8,616,427 B2	12/2013	Viola	8,708,210 B2	4/2014	Zemlok et al.
8,616,431 B2	12/2013	Timm et al.	8,708,211 B2	4/2014	Zemlok et al.
8,622,274 B2	1/2014	Yates et al.	8,708,212 B2	4/2014	Williams
8,622,275 B2	1/2014	Baxter, III et al.	8,708,213 B2	4/2014	Shelton, IV et al.
8,627,993 B2	1/2014	Smith et al.	8,714,352 B2	5/2014	Farascioni et al.
8,627,994 B2	1/2014	Zemlok et al.	8,714,429 B2	5/2014	Demmy
8,627,995 B2	1/2014	Smith et al.	8,714,430 B2	5/2014	Natarajan et al.
8,628,518 B2	1/2014	Blumenkranz et al.	8,715,256 B2	5/2014	Greener
8,628,544 B2	1/2014	Farascioni	8,715,302 B2	5/2014	Ibrahim et al.
8,628,545 B2	1/2014	Cabrera et al.	8,720,766 B2	5/2014	Hess et al.
8,631,987 B2	1/2014	Shelton, IV et al.	8,721,630 B2	5/2014	Ortiz et al.
8,631,992 B1	1/2014	Hausen et al.	8,721,666 B2	5/2014	Schroeder et al.
8,631,993 B2	1/2014	Kostrzewski	8,727,197 B2	5/2014	Hess et al.
8,632,462 B2	1/2014	Yoo et al.	8,727,199 B2	5/2014	Wenchell
8,632,525 B2	1/2014	Kerr et al.	8,727,200 B2	5/2014	Roy
8,632,535 B2	1/2014	Shelton, IV et al.	8,727,961 B2	5/2014	Ziv
8,632,539 B2	1/2014	Twomey et al.	8,728,099 B2	5/2014	Cohn et al.
8,632,563 B2	1/2014	Nagase et al.	8,728,119 B2	5/2014	Cummins
8,636,187 B2	1/2014	Hueil et al.	8,733,470 B2	5/2014	Matthias et al.
8,636,190 B2	1/2014	Zemlok et al.	8,733,611 B2	5/2014	Milliman
8,636,191 B2	1/2014	Meagher	8,733,612 B2	5/2014	Ma
8,636,193 B2	1/2014	Whitman et al.	8,733,613 B2	5/2014	Huitema et al.
8,636,736 B2	1/2014	Yates et al.	8,733,614 B2	5/2014	Ross et al.
8,636,766 B2	1/2014	Milliman et al.	8,734,336 B2	5/2014	Bonadio et al.
8,639,936 B2	1/2014	Hu et al.	8,734,359 B2	5/2014	Ibanez et al.
8,640,788 B2	2/2014	Dachs, II et al.	8,734,478 B2	5/2014	Widenhouse et al.
8,646,674 B2	2/2014	Schulte et al.	8,734,831 B2	5/2014	Kim et al.
8,647,258 B2	2/2014	Aranyi et al.	8,739,033 B2	5/2014	Rosenberg
8,652,120 B2	2/2014	Giordano et al.	8,739,417 B2	6/2014	Tokunaga et al.
8,652,151 B2	2/2014	Lehman et al.	8,740,034 B2	6/2014	Morgan et al.

US D914,878 S

8,740,037 B2	6/2014	Shelton, IV et al.	8,814,025 B2	8/2014	Miller et al.
8,740,038 B2	6/2014	Shelton, IV et al.	8,814,836 B2	8/2014	Ignon et al.
8,740,987 B2	6/2014	Geremakis et al.	8,815,594 B2	8/2014	Harris et al.
8,746,529 B2	6/2014	Shelton, IV et al.	8,818,523 B2	8/2014	Olson et al.
8,746,530 B2	6/2014	Giordano et al.	8,820,603 B2	9/2014	Shelton, IV et al.
8,746,533 B2	6/2014	Whitman et al.	8,820,605 B2	9/2014	Shelton, IV
8,746,535 B2	6/2014	Shelton, IV et al.	8,820,606 B2	9/2014	Hodgkinson
8,747,238 B2	6/2014	Shelton, IV et al.	8,820,607 B2	9/2014	Marczyk
8,747,441 B2	6/2014	Konieczynski et al.	8,820,608 B2	9/2014	Miyamoto
8,752,264 B2	6/2014	Ackley et al.	8,821,514 B2	9/2014	Aranyi
8,752,699 B2	6/2014	Morgan et al.	8,822,934 B2	9/2014	Sayeh et al.
8,752,747 B2	6/2014	Shelton, IV et al.	8,825,164 B2	9/2014	Tweden et al.
8,752,748 B2	6/2014	Whitman et al.	8,827,133 B2	9/2014	Shelton, IV et al.
8,752,749 B2	6/2014	Moore et al.	8,827,134 B2	9/2014	Viola et al.
8,753,664 B2	6/2014	Dao et al.	8,827,903 B2	9/2014	Shelton, IV et al.
8,757,287 B2	6/2014	Mak et al.	8,831,779 B2	9/2014	Ortmaier et al.
8,757,465 B2	6/2014	Woodard, Jr. et al.	8,833,219 B2	9/2014	Pierce
8,758,235 B2	6/2014	Jaworek	8,833,630 B2	9/2014	Milliman
8,758,366 B2	6/2014	McLean et al.	8,833,632 B2	9/2014	Swensgard
8,758,391 B2	6/2014	Swayze et al.	8,834,353 B2	9/2014	Dejima et al.
8,758,438 B2	6/2014	Boyce et al.	8,834,465 B2	9/2014	Ramstein et al.
8,763,875 B2	7/2014	Morgan et al.	8,834,498 B2	9/2014	Byrum et al.
8,763,876 B2	7/2014	Kostrzewski	8,834,518 B2	9/2014	Faller et al.
8,763,877 B2	7/2014	Schall et al.	8,840,003 B2	9/2014	Morgan et al.
8,763,879 B2	7/2014	Shelton, IV et al.	8,840,603 B2	9/2014	Shelton, IV et al.
8,764,732 B2	7/2014	Hartwell	8,840,609 B2	9/2014	Stuebe
8,765,942 B2	7/2014	Feraud et al.	8,840,876 B2	9/2014	Eemeta et al.
8,770,458 B2	7/2014	Scirica	8,844,789 B2	9/2014	Shelton, IV et al.
8,770,459 B2	7/2014	Racenet et al.	8,844,790 B2	9/2014	Demmy et al.
8,770,460 B2	7/2014	Belzer	8,851,215 B2	10/2014	Goto
8,771,169 B2	7/2014	Whitman et al.	8,851,354 B2	10/2014	Swensgard et al.
8,771,260 B2	7/2014	Conlon et al.	8,852,174 B2	10/2014	Burbank
8,777,004 B2	7/2014	Shelton, IV et al.	8,852,185 B2	10/2014	Twomey
8,777,082 B2	7/2014	Scirica	8,852,199 B2	10/2014	Deslauriers et al.
8,777,083 B2	7/2014	Racenet et al.	8,852,218 B2	10/2014	Hughett, Sr. et al.
8,777,898 B2	7/2014	Suon et al.	8,857,693 B2	10/2014	Schuckmann et al.
8,783,541 B2	7/2014	Shelton, IV et al.	8,857,694 B2	10/2014	Shelton, IV et al.
8,783,542 B2	7/2014	Riesterberg et al.	8,858,538 B2	10/2014	Belson et al.
8,783,543 B2	7/2014	Shelton, IV et al.	8,858,571 B2	10/2014	Shelton, IV et al.
8,784,304 B2	7/2014	Mikkaichi et al.	8,858,590 B2	10/2014	Shelton, IV et al.
8,784,404 B2	7/2014	Doyle et al.	8,864,007 B2	10/2014	Widenhouse et al.
8,784,415 B2	7/2014	Malackowski et al.	8,864,009 B2	10/2014	Shelton, IV et al.
8,789,737 B2	7/2014	Hodgkinson et al.	8,864,010 B2	10/2014	Williams
8,789,739 B2	7/2014	Swensgard	8,864,750 B2	10/2014	Ross et al.
8,789,740 B2	7/2014	Baxter, III et al.	8,870,050 B2	10/2014	Hodgkinson
8,789,741 B2	7/2014	Baxter, III et al.	8,870,867 B2	10/2014	Walberg et al.
8,790,658 B2	7/2014	Cigarini et al.	8,870,912 B2	10/2014	Brisson et al.
8,790,684 B2	7/2014	Dave et al.	8,875,971 B2	11/2014	Hall et al.
D711,905 S	8/2014	Morrison et al.	8,875,972 B2	11/2014	Weisenburgh, II et al.
8,794,496 B2	8/2014	Scirica	8,876,857 B2	11/2014	Burbank
8,794,497 B2	8/2014	Zingman	8,876,858 B2	11/2014	Braun
8,795,276 B2	8/2014	Dietz et al.	8,887,979 B2	11/2014	Mastri et al.
8,795,308 B2	8/2014	Valin	8,888,688 B2	11/2014	Julian et al.
8,795,324 B2	8/2014	Kawai et al.	8,888,695 B2	11/2014	Piskun et al.
8,796,995 B2	8/2014	Cunanan et al.	8,888,792 B2	11/2014	Harris et al.
8,800,681 B2	8/2014	Rousson et al.	8,888,809 B2	11/2014	Davison et al.
8,800,837 B2	8/2014	Zemlok	8,893,946 B2	11/2014	Boudreaux et al.
8,800,838 B2	8/2014	Shelton, IV	8,893,949 B2	11/2014	Shelton, IV et al.
8,800,839 B2	8/2014	Beetel	8,894,647 B2	11/2014	Beardsley et al.
8,800,840 B2	8/2014	Jankowski	8,894,654 B2	11/2014	Anderson
8,800,841 B2	8/2014	Ellerhorst et al.	8,899,460 B2	12/2014	Wojcicki
8,801,710 B2	8/2014	Ullrich et al.	8,899,461 B2	12/2014	Farascioni
8,801,734 B2	8/2014	Shelton, IV et al.	8,899,462 B2	12/2014	Kostrzewski et al.
8,801,735 B2	8/2014	Shelton, IV et al.	8,899,463 B2	12/2014	Schall et al.
8,801,752 B2	8/2014	Fortier et al.	8,899,464 B2	12/2014	Hueil et al.
8,801,801 B2	8/2014	Datta et al.	8,899,465 B2	12/2014	Shelton, IV et al.
8,806,973 B2	8/2014	Ross et al.	8,899,466 B2	12/2014	Baxter, III et al.
8,807,414 B2	8/2014	Ross et al.	8,900,267 B2	12/2014	Woolfson et al.
8,808,161 B2	8/2014	Gregg et al.	8,905,287 B2	12/2014	Racenet et al.
8,808,164 B2	8/2014	Hoffman et al.	8,905,977 B2	12/2014	Shelton et al.
8,808,274 B2	8/2014	Hartwell	8,910,846 B2	12/2014	Viola
8,808,294 B2	8/2014	Fox et al.	8,911,426 B2	12/2014	Coppeta et al.
8,808,308 B2	8/2014	Boukhny et al.	8,911,448 B2	12/2014	Stein
8,808,311 B2	8/2014	Heinrich et al.	8,911,460 B2	12/2014	Neurohr et al.
8,808,325 B2	8/2014	Hess et al.	8,911,471 B2	12/2014	Spivey et al.
8,810,197 B2	8/2014	Juergens	8,912,746 B2	12/2014	Reid et al.
8,811,017 B2	8/2014	Fujii et al.	8,920,368 B2	12/2014	Sandhu et al.
8,813,866 B2	8/2014	Suzuki	8,920,433 B2	12/2014	Barrier et al.
8,814,024 B2	8/2014	Woodard, Jr. et al.	8,920,435 B2	12/2014	Smith et al.

US D914,878 S

8,920,438 B2	12/2014	Aranyi et al.	9,011,437 B2	4/2015	Woodruff et al.
8,920,443 B2	12/2014	Hiles et al.	9,011,439 B2	4/2015	Shalaby et al.
8,920,444 B2	12/2014	Hiles et al.	9,011,471 B2	4/2015	Timm et al.
8,922,163 B2	12/2014	Macdonald	9,016,539 B2	4/2015	Kostrzewski et al.
8,925,782 B2	1/2015	Shelton, IV	9,016,540 B2	4/2015	Whitman et al.
8,925,783 B2	1/2015	Zemlok et al.	9,016,541 B2	4/2015	Viola et al.
8,925,788 B2	1/2015	Hess et al.	9,016,542 B2	4/2015	Shelton, IV et al.
8,926,506 B2	1/2015	Widenhouse et al.	9,016,545 B2	4/2015	Aranyi et al.
8,926,598 B2	1/2015	Mollere et al.	9,017,331 B2	4/2015	Fox
8,931,576 B2	1/2015	Iwata	9,017,355 B2	4/2015	Smith et al.
8,931,679 B2	1/2015	Kostrzewski	9,017,369 B2	4/2015	Renger et al.
8,931,680 B2	1/2015	Milliman	9,017,371 B2	4/2015	Whitman et al.
8,931,682 B2	1/2015	Timm et al.	D729,274 S	5/2015	Clement et al.
8,936,614 B2	1/2015	Allen, IV	9,021,684 B2	5/2015	Lenker et al.
8,939,343 B2	1/2015	Milliman et al.	9,023,014 B2	5/2015	Chowaniec et al.
8,939,344 B2	1/2015	Olson et al.	9,023,069 B2	5/2015	Kasvikis et al.
8,944,069 B2	2/2015	Miller et al.	9,023,071 B2	5/2015	Miller et al.
8,945,095 B2	2/2015	Blumenkranz et al.	9,026,347 B2	5/2015	Gadh et al.
8,945,163 B2	2/2015	Voegele et al.	9,027,817 B2	5/2015	Milliman et al.
8,955,732 B2	2/2015	Zemlok et al.	9,028,494 B2	5/2015	Shelton, IV et al.
8,956,342 B1	2/2015	Russo et al.	9,028,495 B2	5/2015	Mueller et al.
8,956,390 B2	2/2015	Shah et al.	9,028,510 B2	5/2015	Miyamoto et al.
8,958,860 B2	2/2015	Banerjee et al.	9,028,511 B2	5/2015	Weller et al.
8,960,519 B2	2/2015	Whitman et al.	9,028,519 B2	5/2015	Yates et al.
8,960,520 B2	2/2015	McCuen	9,030,166 B2	5/2015	Kano
8,960,521 B2	2/2015	Kostrzewski	9,030,169 B2	5/2015	Christensen et al.
8,961,191 B2	2/2015	Hanshew	9,033,203 B2	5/2015	Woodard, Jr. et al.
8,961,504 B2	2/2015	Hoarau et al.	9,033,204 B2	5/2015	Shelton, IV et al.
8,963,714 B2	2/2015	Medhal et al.	9,034,505 B2	5/2015	Detry et al.
D725,674 S	3/2015	Jung et al.	9,038,881 B1	5/2015	Schaller et al.
8,967,443 B2	3/2015	McCuen	9,039,690 B2	5/2015	Kersten et al.
8,967,444 B2	3/2015	Beetel	9,039,694 B2	5/2015	Ross et al.
8,967,446 B2	3/2015	Beardsley et al.	9,039,720 B2	5/2015	Madan
8,967,448 B2	3/2015	Carter et al.	9,043,027 B2	5/2015	Durant et al.
8,968,276 B2	3/2015	Zemlok et al.	9,044,227 B2	6/2015	Shelton, IV et al.
8,968,308 B2	3/2015	Horner et al.	9,044,228 B2	6/2015	Woodard, Jr. et al.
8,968,312 B2	3/2015	Marczyk et al.	9,044,229 B2	6/2015	Scheib et al.
8,968,337 B2	3/2015	Whitfield et al.	9,044,230 B2	6/2015	Morgan et al.
8,968,340 B2	3/2015	Chowaniec et al.	9,044,241 B2	6/2015	Barner et al.
8,968,355 B2	3/2015	Malkowski et al.	9,044,261 B2	6/2015	Houser
8,968,358 B2	3/2015	Reschke	9,044,281 B2	6/2015	Pool et al.
8,970,507 B2	3/2015	Holbein et al.	9,050,083 B2	6/2015	Yates et al.
8,973,803 B2	3/2015	Hall et al.	9,050,084 B2	6/2015	Schmid et al.
8,973,804 B2	3/2015	Hess et al.	9,050,100 B2	6/2015	Yates et al.
8,973,805 B2	3/2015	Scirica et al.	9,050,120 B2	6/2015	Swarup et al.
8,974,440 B2	3/2015	Farritor et al.	9,050,123 B2	6/2015	Krause et al.
8,974,542 B2	3/2015	Fujimoto et al.	9,050,176 B2	6/2015	Datta et al.
8,974,932 B2	3/2015	McGahan et al.	9,050,192 B2	6/2015	Mansmann
8,978,954 B2	3/2015	Shelton, IV et al.	9,055,941 B2	6/2015	Schmid et al.
8,978,955 B2	3/2015	Aronhalt et al.	9,055,942 B2	6/2015	Balbierz et al.
8,978,956 B2	3/2015	Schall et al.	9,055,943 B2	6/2015	Zemlok et al.
8,979,843 B2	3/2015	Timm et al.	9,055,944 B2	6/2015	Hodgkinson et al.
8,979,890 B2	3/2015	Boudreaux	9,055,961 B2	6/2015	Manzo et al.
8,982,195 B2	3/2015	Claus et al.	9,060,770 B2	6/2015	Shelton, IV et al.
8,985,240 B2	3/2015	Winnard	9,060,776 B2	6/2015	Yates et al.
8,985,429 B2	3/2015	Balek et al.	9,060,794 B2	6/2015	Kang et al.
8,986,302 B2	3/2015	Aldridge et al.	9,060,894 B2	6/2015	Wubbeling
8,989,903 B2	3/2015	Weir et al.	9,061,392 B2	6/2015	Forgues et al.
8,991,676 B2	3/2015	Hess et al.	9,072,515 B2	7/2015	Hall et al.
8,991,677 B2	3/2015	Moore et al.	9,072,523 B2	7/2015	Houser et al.
8,991,678 B2	3/2015	Wellman et al.	9,072,535 B2	7/2015	Shelton, IV et al.
8,992,042 B2	3/2015	Eichenholz	9,072,536 B2	7/2015	Shelton, IV et al.
8,992,422 B2	3/2015	Spivey et al.	9,078,653 B2	7/2015	Leimbach et al.
8,992,565 B2	3/2015	Brisson et al.	9,078,654 B2	7/2015	Whitman et al.
8,996,165 B2	3/2015	Wang et al.	9,084,601 B2	7/2015	Moore et al.
8,998,058 B2	4/2015	Moore et al.	9,084,602 B2	7/2015	Gleiman
8,998,059 B2	4/2015	Smith et al.	9,086,875 B2	7/2015	Harrat et al.
8,998,060 B2	4/2015	Bruewer et al.	9,089,326 B2	7/2015	Krumanaker et al.
8,998,061 B2	4/2015	Williams et al.	9,089,330 B2	7/2015	Widenhouse et al.
8,998,939 B2	4/2015	Price et al.	9,089,338 B2	7/2015	Smith et al.
9,000,720 B2	4/2015	Stulen et al.	9,089,352 B2	7/2015	Jeong
9,002,518 B2	4/2015	Manzo et al.	9,089,360 B2	7/2015	Messerly et al.
9,004,339 B1	4/2015	Park	9,091,588 B2	7/2015	Lefler
9,005,230 B2	4/2015	Yates et al.	D736,792 S	8/2015	Brinda et al.
9,005,238 B2	4/2015	DeSantis et al.	9,095,339 B2	8/2015	Moore et al.
9,005,243 B2	4/2015	Stopek et al.	9,095,346 B2	8/2015	Houser et al.
9,010,606 B2	4/2015	Aranyi et al.	9,095,362 B2	8/2015	Dachs, II et al.
9,010,608 B2	4/2015	Casasanta, Jr. et al.	9,095,367 B2	8/2015	Olson et al.
9,010,611 B2	4/2015	Ross et al.	9,096,033 B2	8/2015	Holop et al.

US D914,878 S

9,098,153 B2	8/2015	Shen et al.	9,198,644 B2	12/2015	Balek et al.
9,099,863 B2	8/2015	Smith et al.	9,198,661 B2	12/2015	Swensgard
9,099,877 B2	8/2015	Banos et al.	9,198,662 B2	12/2015	Barton et al.
9,101,358 B2	8/2015	Kerr et al.	9,198,683 B2	12/2015	Friedman et al.
9,101,385 B2	8/2015	Shelton, IV et al.	9,204,830 B2	12/2015	Zand et al.
9,101,475 B2	8/2015	Wei et al.	9,204,877 B2	12/2015	Whitman et al.
9,101,621 B2	8/2015	Zeldis	9,204,878 B2	12/2015	Hall et al.
9,107,663 B2	8/2015	Swensgard	9,204,879 B2	12/2015	Shelton, IV
9,107,667 B2	8/2015	Hodgkinson	9,204,880 B2	12/2015	Baxter, III et al.
9,107,690 B2	8/2015	Bales, Jr. et al.	9,204,881 B2	12/2015	Penna
9,110,587 B2	8/2015	Kim et al.	9,204,923 B2	12/2015	Manzo et al.
9,113,862 B2	8/2015	Morgan et al.	9,204,924 B2	12/2015	Marczyk et al.
9,113,864 B2	8/2015	Morgan et al.	9,211,120 B2	12/2015	Scheib et al.
9,113,865 B2	8/2015	Shelton, IV et al.	9,211,121 B2	12/2015	Hall et al.
9,113,868 B2	8/2015	Felder et al.	9,211,122 B2	12/2015	Hagerty et al.
9,113,873 B2	8/2015	Marczyk et al.	9,216,013 B2	12/2015	Scirica et al.
9,113,874 B2	8/2015	Shelton, IV et al.	9,216,019 B2	12/2015	Schmid et al.
9,113,876 B2	8/2015	Zemlok et al.	9,216,020 B2	12/2015	Zhang et al.
9,113,879 B2	8/2015	Felder et al.	9,216,030 B2	12/2015	Fan et al.
9,113,880 B2	8/2015	Zemlok et al.	9,216,062 B2	12/2015	Duque et al.
9,113,881 B2	8/2015	Scirica	9,220,500 B2	12/2015	Swayze et al.
9,113,883 B2	8/2015	Aronhalt et al.	9,220,501 B2	12/2015	Baxter, III et al.
9,113,884 B2	8/2015	Shelton, IV et al.	9,220,502 B2	12/2015	Zemlok et al.
9,113,887 B2	8/2015	Behnke, II et al.	9,220,508 B2	12/2015	Dannaher
9,119,615 B2	9/2015	Felder et al.	9,220,559 B2	12/2015	Worrell et al.
9,119,657 B2	9/2015	Shelton, IV et al.	9,220,570 B2	12/2015	Kim et al.
9,119,898 B2	9/2015	Bayon et al.	D746,854 S	1/2016	Shardlow et al.
9,119,957 B2	9/2015	Gantz et al.	9,226,750 B2	1/2016	Weir et al.
9,123,286 B2	9/2015	Park	9,226,751 B2	1/2016	Shelton, IV et al.
9,124,097 B2	9/2015	Cruz	9,226,754 B2	1/2016	D'Agostino et al.
9,125,651 B2	9/2015	Mandakolathur Vasudevan et al.	9,226,761 B2	1/2016	Burbank
9,125,654 B2	9/2015	Aronhalt et al.	9,226,767 B2	1/2016	Stulen et al.
9,125,662 B2	9/2015	Shelton, IV	9,232,941 B2	1/2016	Mandakolathur Vasudevan et al.
9,126,317 B2	9/2015	Lawton et al.	9,232,945 B2	1/2016	Zingman
9,131,835 B2	9/2015	Widenhouse et al.	9,232,979 B2	1/2016	Parihar et al.
9,131,940 B2	9/2015	Huitema et al.	9,233,610 B2	1/2016	Kim et al.
9,131,950 B2	9/2015	Matthew	9,237,891 B2	1/2016	Shelton, IV
9,131,957 B2	9/2015	Skarbnik et al.	9,237,892 B2	1/2016	Hodgkinson
9,138,225 B2	9/2015	Huang et al.	9,237,895 B2	1/2016	McCarthy et al.
9,138,226 B2	9/2015	Racenet et al.	9,237,900 B2	1/2016	Boudreaux et al.
9,144,455 B2	9/2015	Kennedy et al.	9,237,921 B2	1/2016	Messerly et al.
D740,414 S	10/2015	Katsura	9,239,064 B2	1/2016	Helbig et al.
D741,882 S	10/2015	Shmilov et al.	9,240,740 B2	1/2016	Zeng et al.
9,149,274 B2	10/2015	Spivey et al.	9,241,711 B2	1/2016	Ivanko
9,149,324 B2	10/2015	Huang et al.	9,241,712 B2	1/2016	Zemlok et al.
9,149,325 B2	10/2015	Worrell et al.	9,241,714 B2	1/2016	Timm et al.
9,153,994 B2	10/2015	Wood et al.	9,241,716 B2	1/2016	Whitman
9,161,753 B2	10/2015	Prior	9,241,731 B2	1/2016	Boudreaux et al.
9,161,769 B2	10/2015	Stoddard et al.	9,244,524 B2	1/2016	Inoue et al.
9,161,803 B2	10/2015	Yates et al.	D748,668 S	2/2016	Kim et al.
9,161,807 B2	10/2015	Garrison	D749,128 S	2/2016	Perez et al.
9,161,855 B2	10/2015	Rousseau et al.	D749,623 S	2/2016	Gray et al.
9,164,271 B2	10/2015	Ebata et al.	D750,122 S	2/2016	Shardlow et al.
9,168,038 B2	10/2015	Shelton, IV et al.	D750,129 S	2/2016	Kwon
9,168,039 B1	10/2015	Knodel	9,254,131 B2	2/2016	Soltz et al.
9,168,042 B2	10/2015	Milliman	9,254,170 B2	2/2016	Parihar et al.
9,168,054 B2	10/2015	Turner et al.	9,259,265 B2	2/2016	Harris et al.
9,168,144 B2	10/2015	Rivin et al.	9,259,274 B2	2/2016	Prisco
9,171,244 B2	10/2015	Endou et al.	9,259,275 B2	2/2016	Burbank
9,179,911 B2	11/2015	Morgan et al.	9,261,172 B2	2/2016	Solomon et al.
9,179,912 B2	11/2015	Yates et al.	9,265,500 B2	2/2016	Sorrentino et al.
9,180,223 B2	11/2015	Yu et al.	9,265,516 B2	2/2016	Casey et al.
9,182,244 B2	11/2015	Luke et al.	9,265,585 B2	2/2016	Wingardner et al.
9,186,046 B2	11/2015	Ramamurthy et al.	9,271,718 B2	3/2016	Milad et al.
9,186,137 B2	11/2015	Farascioni et al.	9,271,727 B2	3/2016	McGuckin, Jr. et al.
9,186,140 B2	11/2015	Hiles et al.	9,271,753 B2	3/2016	Butler et al.
9,186,142 B2	11/2015	Fanelli et al.	9,271,799 B2	3/2016	Shelton, IV et al.
9,186,143 B2	11/2015	Timm et al.	9,272,406 B2	3/2016	Aronhalt et al.
9,186,148 B2	11/2015	Felder et al.	9,274,095 B2	3/2016	Humayun et al.
9,186,221 B2	11/2015	Burbank	9,277,919 B2	3/2016	Timmer et al.
9,192,376 B2	11/2015	Almodovar	9,277,922 B2	3/2016	Carter et al.
9,192,380 B2	11/2015	(Tarinelli) Racenet et al.	9,277,969 B2	3/2016	Brannan et al.
9,192,384 B2	11/2015	Bettuchi	9,282,962 B2	3/2016	Schmid et al.
9,192,430 B2	11/2015	Rachlin et al.	9,282,963 B2	3/2016	Bryant
9,192,434 B2	11/2015	Twomey et al.	9,282,966 B2	3/2016	Shelton, IV et al.
9,193,045 B2	11/2015	Saur et al.	9,282,974 B2	3/2016	Shelton, IV
9,197,079 B2	11/2015	Yip et al.	9,283,028 B2	3/2016	Johnson
D744,528 S	12/2015	Agrawal	9,283,045 B2	3/2016	Rhee et al.
9,198,642 B2	12/2015	Storz	9,283,054 B2	3/2016	Morgan et al.

US D914,878 S

Page 28

9,289,206 B2	3/2016	Hess et al.	9,358,004 B2	6/2016	Sniffin et al.
9,289,207 B2	3/2016	Shelton, IV	9,358,005 B2	6/2016	Shelton, IV et al.
9,289,210 B2	3/2016	Baxter, III et al.	9,358,015 B2	6/2016	Sorrentino et al.
9,289,211 B2	3/2016	Williams et al.	9,358,031 B2	6/2016	Manzo
9,289,212 B2	3/2016	Shelton, IV et al.	9,364,217 B2	6/2016	Kostrzewski et al.
9,289,225 B2	3/2016	Shelton, IV et al.	9,364,219 B2	6/2016	Olson et al.
9,289,256 B2	3/2016	Shelton, IV et al.	9,364,220 B2	6/2016	Williams
9,293,757 B2	3/2016	Toussaint et al.	9,364,226 B2	6/2016	Zemlok et al.
9,295,464 B2	3/2016	Shelton, IV et al.	9,364,229 B2	6/2016	D'Agostino et al.
9,295,465 B2	3/2016	Farascioni	9,364,230 B2	6/2016	Shelton, IV et al.
9,295,466 B2	3/2016	Hodgkinson et al.	9,364,231 B2	6/2016	Wenchell
9,295,467 B2	3/2016	Scirica	9,364,233 B2	6/2016	Alexander, III et al.
9,295,468 B2	3/2016	Heinrich et al.	9,364,279 B2	6/2016	Houser et al.
9,295,514 B2	3/2016	Shelton, IV et al.	9,368,991 B2	6/2016	Qahouq
9,295,522 B2	3/2016	Kostrzewski	9,370,341 B2	6/2016	Ceniccola et al.
9,295,565 B2	3/2016	McLean	9,370,358 B2	6/2016	Shelton, IV et al.
9,295,784 B2	3/2016	Eggert et al.	9,370,362 B2	6/2016	Petty et al.
D753,167 S	4/2016	Yu et al.	9,370,364 B2	6/2016	Smith et al.
9,301,691 B2	4/2016	Hufnagel et al.	9,370,400 B2	6/2016	Parihar
9,301,752 B2	4/2016	Mandakolathur Vasudevan et al.	9,375,206 B2	6/2016	Vidal et al.
9,301,753 B2	4/2016	Aldridge et al.	9,375,218 B2	6/2016	Wheeler et al.
9,301,755 B2	4/2016	Shelton, IV et al.	9,375,230 B2	6/2016	Ross et al.
9,301,759 B2	4/2016	Spivey et al.	9,375,232 B2	6/2016	Hunt et al.
9,307,965 B2	4/2016	Ming et al.	9,375,255 B2	6/2016	Houser et al.
9,307,986 B2	4/2016	Hall et al.	D761,309 S	7/2016	Lee et al.
9,307,987 B2	4/2016	Swensgard et al.	9,381,058 B2	7/2016	Houser et al.
9,307,988 B2	4/2016	Shelton, IV	9,383,881 B2	7/2016	Day et al.
9,307,989 B2	4/2016	Shelton, IV et al.	9,386,983 B2	7/2016	Swensgard et al.
9,307,994 B2	4/2016	Gresham et al.	9,386,984 B2	7/2016	Aronhalt et al.
9,308,009 B2	4/2016	Madan et al.	9,386,985 B2	7/2016	Koch, Jr. et al.
9,308,011 B2	4/2016	Chao et al.	9,386,988 B2	7/2016	Baxter, III et al.
9,308,646 B2	4/2016	Lim et al.	9,387,003 B2	7/2016	Kaercher et al.
9,313,915 B2	4/2016	Niu et al.	9,393,015 B2	7/2016	Laurent et al.
9,314,246 B2	4/2016	Shelton, IV et al.	9,393,017 B2	7/2016	Flanagan et al.
9,314,247 B2	4/2016	Shelton, IV et al.	9,393,018 B2	7/2016	Wang et al.
9,314,261 B2	4/2016	Bales, Jr. et al.	9,396,669 B2	7/2016	Karkanias et al.
9,314,339 B2	4/2016	Mansmann	9,398,911 B2	7/2016	Auld
9,314,908 B2	4/2016	Tanimoto et al.	D763,277 S	8/2016	Ahmed et al.
9,320,518 B2	4/2016	Henderson et al.	D764,498 S	8/2016	Capela et al.
9,320,520 B2	4/2016	Shelton, IV et al.	9,402,604 B2	8/2016	Williams et al.
9,320,521 B2	4/2016	Shelton, IV et al.	9,402,625 B2	8/2016	Coleman et al.
9,320,523 B2	4/2016	Shelton, IV et al.	9,402,626 B2	8/2016	Ortiz et al.
9,325,516 B2	4/2016	Pera et al.	9,402,627 B2	8/2016	Stevenson et al.
D755,196 S	5/2016	Meyers et al.	9,402,629 B2	8/2016	Ehrenfels et al.
D756,373 S	5/2016	Raskin et al.	9,402,679 B2	8/2016	Ginnebaugh et al.
D756,377 S	5/2016	Connolly et al.	9,408,604 B2	8/2016	Shelton, IV et al.
D757,028 S	5/2016	Goldenberg et al.	9,408,606 B2	8/2016	Shelton, IV
9,326,767 B2	5/2016	Koch, Jr. et al.	9,408,622 B2	8/2016	Stulen et al.
9,326,768 B2	5/2016	Shelton, IV	9,411,370 B2	8/2016	Benni et al.
9,326,769 B2	5/2016	Shelton, IV et al.	9,413,128 B2	8/2016	Tien et al.
9,326,770 B2	5/2016	Shelton, IV et al.	9,414,838 B2	8/2016	Shelton, IV et al.
9,326,771 B2	5/2016	Baxter, III et al.	9,414,849 B2	8/2016	Nagashimada
9,326,788 B2	5/2016	Batross et al.	9,414,880 B2	8/2016	Monson et al.
9,326,812 B2	5/2016	Waalder et al.	9,420,967 B2	8/2016	Zand et al.
9,326,824 B2	5/2016	Inoue et al.	9,421,003 B2	8/2016	Williams et al.
9,327,061 B2	5/2016	Govil et al.	9,421,014 B2	8/2016	Ingmanson et al.
9,331,721 B2	5/2016	Martinez Nuevo et al.	9,421,030 B2	8/2016	Cole et al.
9,332,890 B2	5/2016	Ozawa	9,421,060 B2	8/2016	Monson et al.
9,332,974 B2	5/2016	Henderson et al.	9,421,062 B2	8/2016	Houser et al.
9,332,984 B2	5/2016	Weaner et al.	9,427,223 B2	8/2016	Park et al.
9,332,987 B2	5/2016	Leimbach et al.	9,427,231 B2	8/2016	Racenet et al.
9,333,040 B2	5/2016	Shellenberger et al.	D767,624 S	9/2016	Lee et al.
9,333,082 B2	5/2016	Wei et al.	9,433,411 B2	9/2016	Racenet et al.
9,337,668 B2	5/2016	Yip	9,433,414 B2	9/2016	Chen et al.
9,339,226 B2	5/2016	van der Walt et al.	9,433,419 B2	9/2016	Gonzalez et al.
9,345,477 B2	5/2016	Anim et al.	9,433,420 B2	9/2016	Hodgkinson
9,345,479 B2	5/2016	(Tarinelli) Racenet et al.	9,439,649 B2	9/2016	Shelton, IV et al.
9,345,480 B2	5/2016	Hessler et al.	9,439,650 B2	9/2016	McGuckin, Jr. et al.
9,345,481 B2	5/2016	Hall et al.	9,439,651 B2	9/2016	Smith et al.
9,345,503 B2	5/2016	Ishida et al.	9,439,668 B2	9/2016	Timm et al.
9,351,726 B2	5/2016	Leimbach et al.	9,445,808 B2	9/2016	Woodard, Jr. et al.
9,351,727 B2	5/2016	Leimbach et al.	9,445,813 B2	9/2016	Shelton, IV et al.
9,351,728 B2	5/2016	Sniffin et al.	9,445,816 B2	9/2016	Swayze et al.
9,351,730 B2	5/2016	Schmid et al.	9,445,817 B2	9/2016	Bettuchi
9,351,731 B2	5/2016	Carter et al.	9,446,226 B2	9/2016	Zilberman
9,351,732 B2	5/2016	Hodgkinson	9,451,938 B2	9/2016	Overes et al.
D758,433 S	6/2016	Lee et al.	9,451,958 B2	9/2016	Shelton, IV et al.
D759,063 S	6/2016	Chen	D768,152 S	10/2016	Gutierrez et al.
9,358,003 B2	6/2016	Hall et al.	D768,156 S	10/2016	Frincke

US D914,878 S

D768,167 S	10/2016	Jones et al.	9,566,065 B2	2/2017	Knodel
D769,315 S	10/2016	Scotti	9,566,067 B2	2/2017	Milliman et al.
D769,930 S	10/2016	Agrawal	9,572,574 B2	2/2017	Shelton, IV et al.
9,461,340 B2	10/2016	Li et al.	9,572,576 B2	2/2017	Hodgkinson et al.
9,463,040 B2	10/2016	Jeong et al.	9,572,577 B2	2/2017	Lloyd et al.
9,463,260 B2	10/2016	Stopek	9,572,592 B2	2/2017	Price et al.
9,468,438 B2	10/2016	Baber et al.	9,574,644 B2	2/2017	Parihar
9,468,447 B2	10/2016	Aman et al.	9,579,088 B2	2/2017	Farritor et al.
9,470,297 B2	10/2016	Aranyi et al.	9,579,143 B2	2/2017	Ullrich et al.
9,471,969 B2	10/2016	Zeng et al.	9,579,158 B2	2/2017	Brianza et al.
9,474,506 B2	10/2016	Magnin et al.	D780,803 S	3/2017	Gill et al.
9,474,523 B2	10/2016	Meade et al.	D781,879 S	3/2017	Butcher et al.
9,474,540 B2	10/2016	Stokes et al.	D782,530 S	3/2017	Paek et al.
9,475,180 B2	10/2016	Eshleman et al.	9,585,550 B2	3/2017	Abel et al.
D770,476 S	11/2016	Jitkoff et al.	9,585,657 B2	3/2017	Shelton, IV et al.
D770,515 S	11/2016	Cho et al.	9,585,658 B2	3/2017	Shelton, IV
D771,116 S	11/2016	Dellinger et al.	9,585,659 B2	3/2017	Viola et al.
D772,905 S	11/2016	Ingenlath	9,585,660 B2	3/2017	Laurent et al.
9,480,476 B2	11/2016	Aldridge et al.	9,585,662 B2	3/2017	Shelton, IV et al.
9,480,492 B2	11/2016	Aranyi et al.	9,585,663 B2	3/2017	Shelton, IV et al.
9,483,095 B2	11/2016	Tran et al.	9,585,672 B2	3/2017	Bastia
9,486,186 B2	11/2016	Fiebig et al.	9,590,433 B2	3/2017	Li
9,486,213 B2	11/2016	Altman et al.	9,592,050 B2	3/2017	Schmid et al.
9,486,214 B2	11/2016	Shelton, IV	9,592,052 B2	3/2017	Shelton, IV
9,486,302 B2	11/2016	Boey et al.	9,592,053 B2	3/2017	Shelton, IV et al.
9,488,197 B2	11/2016	Wi	9,592,054 B2	3/2017	Schmid et al.
9,492,146 B2	11/2016	Kostrzewski et al.	9,597,073 B2	3/2017	Sorrentino et al.
9,492,167 B2	11/2016	Shelton, IV et al.	9,597,075 B2	3/2017	Shelton, IV et al.
9,492,170 B2	11/2016	Bear et al.	9,597,078 B2	3/2017	Scirica et al.
9,492,189 B2	11/2016	Williams et al.	9,597,080 B2	3/2017	Milliman et al.
9,492,192 B2	11/2016	To et al.	9,597,104 B2	3/2017	Nicholas et al.
9,492,237 B2	11/2016	Kang et al.	9,597,143 B2	3/2017	Madan et al.
9,498,213 B2	11/2016	Marczyk et al.	9,603,595 B2	3/2017	Shelton, IV et al.
9,498,219 B2	11/2016	Moore et al.	9,603,598 B2	3/2017	Shelton, IV et al.
9,498,231 B2	11/2016	Haider et al.	9,603,599 B2	3/2017	Miller et al.
9,504,455 B2	11/2016	Whitman et al.	9,603,991 B2	3/2017	Shelton, IV et al.
9,504,483 B2	11/2016	Houser et al.	D783,658 S	4/2017	Hurst et al.
9,504,521 B2	11/2016	Deutmeyer et al.	9,610,068 B2	4/2017	Kappel et al.
D774,547 S	12/2016	Capela et al.	9,610,079 B2	4/2017	Kamei et al.
D775,336 S	12/2016	Shelton, IV et al.	9,610,080 B2	4/2017	Whitfield et al.
9,510,827 B2	12/2016	Kostrzewski	9,614,258 B2	4/2017	Takahashi et al.
9,510,828 B2	12/2016	Yates et al.	9,615,826 B2	4/2017	Shelton, IV et al.
9,510,830 B2	12/2016	Shelton, IV et al.	9,622,745 B2	4/2017	Ingmanson et al.
9,510,846 B2	12/2016	Sholev et al.	9,622,746 B2	4/2017	Simms et al.
9,510,895 B2	12/2016	Houser et al.	9,629,623 B2	4/2017	Lytle, IV et al.
9,510,925 B2	12/2016	Hotter et al.	9,629,626 B2	4/2017	Soltz et al.
9,517,063 B2	12/2016	Swayze et al.	9,629,627 B2	4/2017	Kostrzewski et al.
9,517,068 B2	12/2016	Shelton, IV et al.	9,629,628 B2	4/2017	Aranyi
9,517,326 B2	12/2016	Hinman et al.	9,629,629 B2	4/2017	Leimbach et al.
9,521,996 B2	12/2016	Armstrong	9,629,632 B2	4/2017	Linder et al.
9,522,003 B2	12/2016	Weir et al.	9,629,652 B2	4/2017	Mumaw et al.
9,522,014 B2	12/2016	Nishizawa et al.	9,629,814 B2	4/2017	Widenhouse et al.
9,522,029 B2	12/2016	Yates et al.	D785,794 S	5/2017	Magno, Jr.
9,526,481 B2	12/2016	Storz et al.	D786,280 S	5/2017	Ma
9,526,499 B2	12/2016	Kostrzewski et al.	D786,896 S	5/2017	Kim et al.
9,526,563 B2	12/2016	Twomey	D787,547 S	5/2017	Basargin et al.
9,526,564 B2	12/2016	Rusin	D788,123 S	5/2017	Shan et al.
D776,683 S	1/2017	Gobinski et al.	D788,140 S	5/2017	Hemsley et al.
D777,773 S	1/2017	Shi	9,636,091 B2	5/2017	Beardsley et al.
9,532,783 B2	1/2017	Swayze et al.	9,636,111 B2	5/2017	Wenchell
9,539,060 B2	1/2017	Lightcap et al.	9,636,113 B2	5/2017	Wenchell
9,539,726 B2	1/2017	Simaan et al.	9,636,850 B2	5/2017	Stopek (nee Prommersberger) et al.
9,545,253 B2	1/2017	Worrell et al.			
9,545,258 B2	1/2017	Smith et al.	9,641,122 B2	5/2017	Romanowich et al.
9,549,732 B2	1/2017	Yates et al.	9,642,620 B2	5/2017	Baxter, III et al.
9,549,735 B2	1/2017	Shelton, IV et al.	9,649,096 B2	5/2017	Sholev
9,554,794 B2	1/2017	Baber et al.	9,649,110 B2	5/2017	Parihar et al.
9,554,796 B2	1/2017	Kostrzewski	9,649,111 B2	5/2017	Shelton, IV et al.
9,554,812 B2	1/2017	Inkpen et al.	9,649,190 B2	5/2017	Mathies
9,559,624 B2	1/2017	Philipp	9,655,613 B2	5/2017	Schaller
9,561,013 B2	2/2017	Tsuchiya	9,655,614 B2	5/2017	Swensgard et al.
9,561,029 B2	2/2017	Scheib et al.	9,655,615 B2	5/2017	Knodel et al.
9,561,030 B2	2/2017	Zhang et al.	9,655,616 B2	5/2017	Aranyi
9,561,031 B2	2/2017	Heinrich et al.	9,655,624 B2	5/2017	Shelton, IV et al.
9,561,032 B2	2/2017	Shelton, IV et al.	9,662,108 B2	5/2017	Williams
9,561,038 B2	2/2017	Shelton, IV et al.	9,662,110 B2	5/2017	Huang et al.
9,561,045 B2	2/2017	Hinman et al.	9,662,116 B2	5/2017	Smith et al.
9,566,061 B2	2/2017	Aronhalt et al.	9,662,131 B2	5/2017	Omori et al.
9,566,062 B2	2/2017	Boudreaux	D788,792 S	6/2017	Alessandri et al.

US D914,878 S

D789,384 S	6/2017	Lin et al.	9,737,365 B2	8/2017	Hegeman et al.
D790,570 S	6/2017	Butcher et al.	9,743,927 B2	8/2017	Whitman
9,668,728 B2	6/2017	Williams et al.	9,743,928 B2	8/2017	Shelton, IV et al.
9,668,729 B2	6/2017	Williams et al.	9,743,929 B2	8/2017	Leimbach et al.
9,668,732 B2	6/2017	Patel et al.	D798,319 S	9/2017	Bergstrand et al.
9,668,733 B2	6/2017	Williams	9,750,498 B2	9/2017	Timm et al.
9,668,734 B2	6/2017	Kostrzewski et al.	9,750,499 B2	9/2017	Leimbach et al.
9,668,735 B2	6/2017	Beetel	9,750,501 B2	9/2017	Shelton, IV et al.
9,675,344 B2	6/2017	Combrowski et al.	9,750,502 B2	9/2017	Scirica et al.
9,675,351 B2	6/2017	Hodgkinson et al.	9,750,639 B2	9/2017	Barnes et al.
9,675,354 B2	6/2017	Weir et al.	9,757,123 B2	9/2017	Giordano et al.
9,675,355 B2	6/2017	Shelton, IV et al.	9,757,124 B2	9/2017	Schellin et al.
9,675,368 B2	6/2017	Guo et al.	9,757,126 B2	9/2017	Cappola
9,675,372 B2	6/2017	Laurent et al.	9,757,128 B2	9/2017	Baber et al.
9,675,375 B2	6/2017	Houser et al.	9,757,129 B2	9/2017	Williams
9,675,405 B2	6/2017	Trees et al.	9,757,130 B2	9/2017	Shelton, IV
9,675,819 B2	6/2017	Dunbar et al.	9,763,662 B2	9/2017	Shelton, IV et al.
9,681,870 B2	6/2017	Baxter, III et al.	9,763,668 B2	9/2017	Whitfield et al.
9,681,873 B2	6/2017	Smith et al.	9,770,245 B2	9/2017	Swayze et al.
9,681,884 B2	6/2017	Clem et al.	9,770,274 B2	9/2017	Pool et al.
9,687,230 B2	6/2017	Leimbach et al.	D798,886 S	10/2017	Prophete et al.
9,687,231 B2	6/2017	Baxter, III et al.	D800,742 S	10/2017	Rhodes
9,687,232 B2	6/2017	Shelton, IV et al.	D800,744 S	10/2017	Jitkoff et al.
9,687,233 B2	6/2017	Fernandez et al.	D800,766 S	10/2017	Park et al.
9,687,236 B2	6/2017	Leimbach et al.	D800,904 S	10/2017	Leimbach et al.
9,687,237 B2	6/2017	Schmid et al.	9,775,608 B2	10/2017	Aronhalt et al.
9,687,253 B2	6/2017	Detry et al.	9,775,609 B2	10/2017	Shelton, IV et al.
9,689,466 B2	6/2017	Kanai et al.	9,775,610 B2	10/2017	Nicholas et al.
9,690,362 B2	6/2017	Leimbach et al.	9,775,611 B2	10/2017	Kostrzewski
9,693,772 B2	7/2017	Ingmanson et al.	9,775,613 B2	10/2017	Shelton, IV et al.
9,693,774 B2	7/2017	Gettinger et al.	9,775,614 B2	10/2017	Shelton, IV et al.
9,693,775 B2	7/2017	Agarwal et al.	9,775,618 B2	10/2017	Bettuchi et al.
9,693,777 B2	7/2017	Schellin et al.	9,775,635 B2	10/2017	Takei
9,700,309 B2	7/2017	Jaworek et al.	9,775,678 B2	10/2017	Lohmeier
9,700,310 B2	7/2017	Morgan et al.	9,782,169 B2	10/2017	Kimsey et al.
9,700,312 B2	7/2017	Kostrzewski et al.	9,782,170 B2	10/2017	Zemlok et al.
9,700,314 B2	7/2017	Marczyk	9,782,180 B2	10/2017	Smith et al.
9,700,317 B2	7/2017	Aronhalt et al.	9,782,187 B2	10/2017	Zergiebel et al.
9,700,318 B2	7/2017	Scirica et al.	9,782,193 B2	10/2017	Thistle
9,700,319 B2	7/2017	Motooka et al.	9,782,214 B2	10/2017	Houser et al.
9,700,320 B2	7/2017	Dinando et al.	9,788,834 B2	10/2017	Schmid et al.
9,700,321 B2	7/2017	Shelton, IV et al.	9,788,835 B2	10/2017	Morgan et al.
9,706,674 B2	7/2017	Collins et al.	9,788,836 B2	10/2017	Overmyer et al.
9,706,981 B2	7/2017	Nicholas et al.	9,788,847 B2	10/2017	Jinno
9,706,991 B2	7/2017	Hess et al.	9,788,851 B2	10/2017	Dannaher et al.
9,706,993 B2	7/2017	Hessler et al.	9,788,902 B2	10/2017	Inoue et al.
9,707,003 B2	7/2017	Hoell, Jr. et al.	9,795,379 B2	10/2017	Leimbach et al.
9,707,005 B2	7/2017	Strobl et al.	9,795,380 B2	10/2017	Shelton, IV et al.
9,707,026 B2	7/2017	Malackowski et al.	9,795,381 B2	10/2017	Shelton, IV
9,707,033 B2	7/2017	Parihar et al.	9,795,382 B2	10/2017	Shelton, IV
9,707,043 B2	7/2017	Bozung	9,795,383 B2	10/2017	Aldridge et al.
9,707,684 B2	7/2017	Ruiz Morales et al.	9,795,384 B2	10/2017	Weaner et al.
9,713,468 B2	7/2017	Harris et al.	9,797,486 B2	10/2017	Zergiebel et al.
9,713,470 B2	7/2017	Scirica et al.	9,801,626 B2	10/2017	Parihar et al.
9,713,474 B2	7/2017	Lorenz	9,801,627 B2	10/2017	Harris et al.
D795,919 S	8/2017	Bischoff et al.	9,801,628 B2	10/2017	Harris et al.
9,717,497 B2	8/2017	Zerkle et al.	9,801,634 B2	10/2017	Shelton, IV et al.
9,717,498 B2	8/2017	Aranyi et al.	9,802,033 B2	10/2017	Hibner et al.
9,718,190 B2	8/2017	Larkin et al.	9,804,618 B2	10/2017	Leimbach et al.
9,722,236 B2	8/2017	Sathrum	D803,234 S	11/2017	Day et al.
9,724,091 B2	8/2017	Shelton, IV et al.	D803,235 S	11/2017	Markson et al.
9,724,092 B2	8/2017	Baxter, III et al.	D803,850 S	11/2017	Chang et al.
9,724,094 B2	8/2017	Baber et al.	9,808,244 B2	11/2017	Leimbach et al.
9,724,095 B2	8/2017	Gupta et al.	9,808,246 B2	11/2017	Shelton, IV et al.
9,724,096 B2	8/2017	Thompson et al.	9,808,247 B2	11/2017	Shelton, IV et al.
9,724,098 B2	8/2017	Baxter, III et al.	9,808,248 B2	11/2017	Hoffman
9,724,118 B2	8/2017	Schulte et al.	9,808,249 B2	11/2017	Shelton, IV
9,724,163 B2	8/2017	Orban	9,814,460 B2	11/2017	Kimsey et al.
9,730,692 B2	8/2017	Shelton, IV et al.	9,814,462 B2	11/2017	Woodard, Jr. et al.
9,730,695 B2	8/2017	Leimbach et al.	9,814,463 B2	11/2017	Williams et al.
9,730,697 B2	8/2017	Morgan et al.	9,814,530 B2	11/2017	Weir et al.
9,730,717 B2	8/2017	Katsuki et al.	9,814,561 B2	11/2017	Forsell
9,731,410 B2	8/2017	Hirabayashi et al.	9,820,445 B2	11/2017	Simpson et al.
9,733,663 B2	8/2017	Leimbach et al.	9,820,737 B2	11/2017	Beardsley et al.
9,737,297 B2	8/2017	Racenet et al.	9,820,738 B2	11/2017	Lytle, IV et al.
9,737,299 B2	8/2017	Yan	9,820,741 B2	11/2017	Kostrzewski
9,737,301 B2	8/2017	Baber et al.	9,820,768 B2	11/2017	Gee et al.
9,737,302 B2	8/2017	Shelton, IV et al.	9,825,455 B2	11/2017	Sandhu et al.
9,737,303 B2	8/2017	Shelton, IV et al.	9,826,976 B2	11/2017	Parihar et al.

US D914,878 S

9,826,977 B2	11/2017	Leimbach et al.	9,913,641 B2	3/2018	Takemoto et al.
9,826,978 B2	11/2017	Shelton, IV et al.	9,913,642 B2	3/2018	Leimbach et al.
9,829,698 B2	11/2017	Haraguchi et al.	9,913,644 B2	3/2018	McCuen
D806,108 S	12/2017	Day	9,913,646 B2	3/2018	Shelton, IV
9,833,236 B2	12/2017	Shelton, IV et al.	9,913,647 B2	3/2018	Weisenburgh, II et al.
9,833,238 B2	12/2017	Baxter, III et al.	9,913,648 B2	3/2018	Shelton, IV et al.
9,833,239 B2	12/2017	Yates et al.	9,913,694 B2	3/2018	Brisson
9,833,241 B2	12/2017	Huitema et al.	9,913,733 B2	3/2018	Piron et al.
9,833,242 B2	12/2017	Baxter, III et al.	9,918,704 B2	3/2018	Shelton, IV et al.
9,839,420 B2	12/2017	Shelton, IV et al.	9,918,714 B2	3/2018	Gibbons, Jr.
9,839,421 B2	12/2017	Zerkle et al.	9,918,715 B2	3/2018	Menn
9,839,422 B2	12/2017	Schellin et al.	9,918,716 B2	3/2018	Baxter, III et al.
9,839,423 B2	12/2017	Vendely et al.	9,918,717 B2	3/2018	Czernik
9,839,427 B2	12/2017	Swayze et al.	9,918,730 B2	3/2018	Trees et al.
9,839,428 B2	12/2017	Baxter, III et al.	9,924,941 B2	3/2018	Burbank
9,839,429 B2	12/2017	Weisenburgh, II et al.	9,924,942 B2	3/2018	Swayze et al.
9,839,480 B2	12/2017	Pribanic et al.	9,924,944 B2	3/2018	Shelton, IV et al.
9,844,368 B2	12/2017	Boudreaux et al.	9,924,945 B2	3/2018	Zheng et al.
9,844,369 B2	12/2017	Huitema et al.	9,924,946 B2	3/2018	Vendely et al.
9,844,372 B2	12/2017	Shelton, IV et al.	9,924,947 B2	3/2018	Shelton, IV et al.
9,844,373 B2	12/2017	Swayze et al.	9,924,961 B2	3/2018	Shelton, IV et al.
9,844,374 B2	12/2017	Lytle, IV et al.	9,931,106 B2	4/2018	Au et al.
9,844,375 B2	12/2017	Overmyer et al.	9,931,116 B2	4/2018	Racenet et al.
9,844,376 B2	12/2017	Baxter, III et al.	9,931,118 B2	4/2018	Shelton, IV et al.
9,844,379 B2	12/2017	Shelton, IV et al.	9,931,120 B2	4/2018	Chen et al.
9,848,871 B2	12/2017	Harris et al.	9,936,949 B2	4/2018	Measamer et al.
9,848,873 B2	12/2017	Shelton, IV	9,936,950 B2	4/2018	Shelton, IV et al.
9,848,875 B2	12/2017	Aronhalt et al.	9,936,951 B2	4/2018	Hufnagel et al.
9,848,877 B2	12/2017	Shelton, IV et al.	9,936,954 B2	4/2018	Shelton, IV et al.
9,850,994 B2	12/2017	Schena	9,937,626 B2	4/2018	Rockrohr
D808,989 S	1/2018	Ayvazian et al.	9,943,309 B2	4/2018	Shelton, IV et al.
9,855,039 B2	1/2018	Racenet et al.	9,943,310 B2	4/2018	Harris et al.
9,855,040 B2	1/2018	Kostrzewski	9,943,312 B2	4/2018	Posada et al.
9,855,662 B2	1/2018	Ruiz Morales et al.	9,953,193 B2	4/2018	Butler et al.
9,861,261 B2	1/2018	Shahinian	D819,072 S	5/2018	Clediere
9,861,359 B2	1/2018	Shelton, IV et al.	9,955,954 B2	5/2018	Destoumieux et al.
9,861,361 B2	1/2018	Aronhalt et al.	9,955,965 B2	5/2018	Chen et al.
9,861,362 B2	1/2018	Whitman et al.	9,955,966 B2	5/2018	Zergiebel
9,861,366 B2	1/2018	Aranyi	9,962,129 B2	5/2018	Jerebko et al.
9,861,382 B2	1/2018	Smith et al.	9,962,157 B2	5/2018	Sapre
9,861,446 B2	1/2018	Lang	9,962,158 B2	5/2018	Hall et al.
9,867,612 B2	1/2018	Parihar et al.	9,962,159 B2	5/2018	Heinrich et al.
9,867,613 B2	1/2018	Marczyk et al.	9,962,161 B2	5/2018	Scheib et al.
9,867,615 B2	1/2018	Fanelli et al.	9,968,354 B2	5/2018	Shelton, IV et al.
9,867,618 B2	1/2018	Hall et al.	9,968,355 B2	5/2018	Shelton, IV et al.
9,867,620 B2	1/2018	Fischvogt et al.	9,968,356 B2	5/2018	Shelton, IV et al.
9,868,198 B2	1/2018	Nicholas et al.	9,968,397 B2	5/2018	Taylor et al.
9,872,682 B2	1/2018	Hess et al.	9,974,529 B2	5/2018	Shelton, IV et al.
9,872,683 B2	1/2018	Hopkins et al.	9,974,538 B2	5/2018	Baxter, III et al.
9,872,684 B2	1/2018	Hall et al.	9,974,539 B2	5/2018	Yates et al.
9,872,722 B2	1/2018	Lech	9,974,541 B2	5/2018	Calderoni
9,877,721 B2	1/2018	Schellin et al.	9,974,542 B2	5/2018	Hodgkinson
9,877,723 B2	1/2018	Hall et al.	9,980,713 B2	5/2018	Aronhalt et al.
9,877,776 B2	1/2018	Boudreaux	9,980,724 B2	5/2018	Farascioni et al.
D810,099 S	2/2018	Riedel	9,980,729 B2	5/2018	Moore et al.
9,883,843 B2	2/2018	Garlow	9,980,769 B2	5/2018	Trees et al.
9,883,860 B2	2/2018	Leimbach et al.	D819,680 S	6/2018	Nguyen
9,883,861 B2	2/2018	Shelton, IV et al.	D819,682 S	6/2018	Howard et al.
9,884,456 B2	2/2018	Schellin et al.	D819,684 S	6/2018	Dart
9,888,919 B2	2/2018	Leimbach et al.	D820,307 S	6/2018	Jian et al.
9,888,921 B2	2/2018	Williams et al.	D820,867 S	6/2018	Dickens et al.
9,888,924 B2	2/2018	Ebersole et al.	9,987,000 B2	6/2018	Shelton, IV et al.
9,889,230 B2	2/2018	Bennett et al.	9,987,003 B2	6/2018	Timm et al.
9,895,147 B2	2/2018	Shelton, IV	9,987,006 B2	6/2018	Morgan et al.
9,895,148 B2	2/2018	Shelton, IV et al.	9,987,095 B2	6/2018	Chowaniec et al.
9,895,813 B2	2/2018	Blumenkranz et al.	9,987,097 B2	6/2018	van der Weide et al.
9,901,339 B2	2/2018	Farascioni	9,987,099 B2	6/2018	Chen et al.
9,901,341 B2	2/2018	Kostrzewski	9,993,248 B2	6/2018	Shelton, IV et al.
9,901,342 B2	2/2018	Shelton, IV et al.	9,993,258 B2	6/2018	Shelton, IV et al.
9,901,344 B2	2/2018	Moore et al.	9,999,408 B2	6/2018	Boudreaux et al.
9,901,345 B2	2/2018	Moore et al.	9,999,423 B2	6/2018	Schuckmann et al.
9,901,346 B2	2/2018	Moore et al.	9,999,426 B2	6/2018	Moore et al.
9,901,406 B2	2/2018	State et al.	9,999,431 B2	6/2018	Shelton, IV et al.
9,901,412 B2	2/2018	Lathrop et al.	9,999,472 B2	6/2018	Weir et al.
D813,899 S	3/2018	Erant et al.	10,004,497 B2	6/2018	Overmyer et al.
9,907,456 B2	3/2018	Miyoshi	10,004,498 B2	6/2018	Morgan et al.
9,907,553 B2	3/2018	Cole et al.	10,004,500 B2	6/2018	Shelton, IV et al.
9,907,600 B2	3/2018	Stulen et al.	10,004,501 B2	6/2018	Shelton, IV et al.
9,907,620 B2	3/2018	Shelton, IV et al.	10,004,505 B2	6/2018	Moore et al.

US D914,878 S

10,004,506 B2	6/2018	Shelton, IV et al.	10,106,932 B2	10/2018	Anderson et al.
D822,206 S	7/2018	Shelton, IV et al.	10,111,657 B2	10/2018	McCuen
10,010,322 B2	7/2018	Shelton, IV et al.	10,111,660 B2	10/2018	Hemmann
10,010,324 B2	7/2018	Huitema et al.	10,111,679 B2	10/2018	Baber et al.
10,013,049 B2	7/2018	Leimbach et al.	10,111,698 B2	10/2018	Scheib et al.
10,016,199 B2	7/2018	Baber et al.	10,111,702 B2	10/2018	Kostrzewski
10,016,656 B2	7/2018	Devor et al.	10,117,649 B2	11/2018	Baxter, III et al.
10,022,125 B2	7/2018	(Prommersberger) Stopek	10,117,650 B2	11/2018	Nicholas et al.
10,024,407 B2	7/2018	Aranyi et al.	10,117,652 B2	11/2018	Schmid et al.
10,028,742 B2	7/2018	Shelton, IV et al.	10,117,653 B2	11/2018	Leimbach et al.
10,028,743 B2	7/2018	Shelton, IV et al.	10,117,654 B2	11/2018	Ingmanson et al.
10,028,744 B2	7/2018	Shelton, IV et al.	10,123,798 B2	11/2018	Baxter, III et al.
10,028,761 B2	7/2018	Leimbach et al.	10,124,493 B2	11/2018	Rothfuss et al.
10,029,108 B2	7/2018	Powers et al.	10,130,352 B2	11/2018	Widenhouse et al.
10,029,125 B2	7/2018	Shapiro et al.	10,130,359 B2	11/2018	Hess et al.
10,034,344 B2	7/2018	Yoshida	10,130,361 B2	11/2018	Yates et al.
10,034,668 B2	7/2018	Ebner	10,130,363 B2	11/2018	Huitema et al.
D826,405 S	8/2018	Shelton, IV et al.	10,130,366 B2	11/2018	Shelton, IV et al.
10,039,440 B2	8/2018	Fenech et al.	10,130,367 B2	11/2018	Cappola et al.
10,039,529 B2	8/2018	Kerr et al.	10,130,738 B2	11/2018	Shelton, IV et al.
10,039,532 B2	8/2018	Srinivas et al.	10,130,830 B2	11/2018	Miret Carceller et al.
10,039,545 B2	8/2018	Sadowski et al.	10,133,248 B2	11/2018	Fitzsimmons et al.
10,041,822 B2	8/2018	Zemlok	10,135,242 B2	11/2018	Baber et al.
10,045,769 B2	8/2018	Aronhalt et al.	10,136,879 B2	11/2018	Ross et al.
10,045,776 B2	8/2018	Shelton, IV et al.	10,136,887 B2	11/2018	Shelton, IV et al.
10,045,778 B2	8/2018	Yates et al.	10,136,889 B2	11/2018	Shelton, IV et al.
10,045,779 B2	8/2018	Savage et al.	10,136,890 B2	11/2018	Shelton, IV et al.
10,045,781 B2	8/2018	Cropper et al.	10,136,891 B2	11/2018	Shelton, IV et al.
10,045,782 B2	8/2018	Murthy Aravalli	D835,659 S	12/2018	Anzures et al.
10,052,044 B2	8/2018	Shelton, IV et al.	D836,124 S	12/2018	Fan
10,052,099 B2	8/2018	Morgan et al.	10,143,474 B2	12/2018	Bucciaglia et al.
10,052,100 B2	8/2018	Morgan et al.	10,149,679 B2	12/2018	Shelton, IV et al.
10,052,102 B2	8/2018	Baxter, III et al.	10,149,680 B2	12/2018	Parihar et al.
10,052,104 B2	8/2018	Shelton, IV et al.	10,149,682 B2	12/2018	Shelton, IV et al.
10,052,164 B2	8/2018	Overmyer	10,149,683 B2	12/2018	Smith et al.
10,058,317 B2	8/2018	Fan et al.	10,149,712 B2	12/2018	Manwaring et al.
10,058,327 B2	8/2018	Weisenburgh, II et al.	10,154,841 B2	12/2018	Weaner et al.
10,058,373 B2	8/2018	Takashino et al.	10,159,481 B2	12/2018	Whitman et al.
10,058,395 B2	8/2018	Devengenzo et al.	10,159,482 B2	12/2018	Swayze et al.
10,058,963 B2	8/2018	Shelton, IV et al.	10,159,483 B2	12/2018	Beckman et al.
10,064,620 B2	9/2018	Gettinger et al.	10,159,506 B2	12/2018	Boudreaux et al.
10,064,621 B2	9/2018	Kerr et al.	10,163,065 B1	12/2018	Koski et al.
10,064,624 B2	9/2018	Shelton, IV et al.	10,163,589 B2	12/2018	Zergiebel et al.
10,064,639 B2	9/2018	Ishida et al.	D837,244 S	1/2019	Kuo et al.
10,064,649 B2	9/2018	Golebieski et al.	D837,245 S	1/2019	Kuo et al.
10,064,688 B2	9/2018	Shelton, IV et al.	10,166,023 B2	1/2019	Vendely et al.
10,070,861 B2	9/2018	Spivey et al.	10,166,025 B2	1/2019	Leimbach et al.
10,070,863 B2	9/2018	Swayze et al.	10,166,026 B2	1/2019	Shelton, IV et al.
10,071,452 B2	9/2018	Shelton, IV et al.	10,172,611 B2	1/2019	Shelton, IV et al.
10,076,325 B2	9/2018	Huang et al.	10,172,615 B2	1/2019	Marczyk et al.
10,076,326 B2	9/2018	Yates et al.	10,172,616 B2	1/2019	Murray et al.
10,076,340 B2	9/2018	Belagali et al.	10,172,617 B2	1/2019	Shelton, IV et al.
D831,209 S	10/2018	Huitema et al.	10,172,619 B2	1/2019	Harris et al.
D831,676 S	10/2018	Park et al.	10,172,620 B2	1/2019	Harris et al.
D832,301 S	10/2018	Smith	10,172,636 B2	1/2019	Stulen et al.
10,085,624 B2	10/2018	Isoda et al.	10,175,127 B2	1/2019	Collins et al.
10,085,643 B2	10/2018	Bandic et al.	10,178,992 B2	1/2019	Wise et al.
10,085,728 B2	10/2018	Jogasaki et al.	10,180,463 B2	1/2019	Beckman et al.
10,085,746 B2	10/2018	Fischvogt	10,182,813 B2	1/2019	Leimbach et al.
10,085,748 B2	10/2018	Morgan et al.	10,182,815 B2	1/2019	Williams et al.
10,085,749 B2	10/2018	Cappola et al.	10,182,816 B2	1/2019	Shelton, IV et al.
10,085,750 B2	10/2018	Zergiebel et al.	10,182,818 B2*	1/2019	Hensel A61B 17/072
10,085,751 B2	10/2018	Overmyer et al.	10,182,819 B2	1/2019	Shelton, IV
10,085,754 B2	10/2018	Sniffin et al.	10,188,385 B2	1/2019	Kerr et al.
10,085,806 B2	10/2018	Hagn et al.	10,188,393 B2	1/2019	Smith et al.
10,092,290 B2	10/2018	Yigit et al.	10,188,394 B2	1/2019	Shelton, IV et al.
10,092,292 B2	10/2018	Boudreaux et al.	D839,900 S	2/2019	Gan
10,098,635 B2	10/2018	Burbank	D841,667 S	2/2019	Coren
10,098,636 B2	10/2018	Shelton, IV et al.	10,194,801 B2	2/2019	Elhawary et al.
10,098,638 B2	10/2018	Viola et al.	10,194,904 B2	2/2019	Viola et al.
10,098,640 B2	10/2018	Bertolero et al.	10,194,907 B2	2/2019	Marczyk et al.
10,098,642 B2	10/2018	Baxter, III et al.	10,194,908 B2	2/2019	Duque et al.
10,099,303 B2	10/2018	Yoshida et al.	10,194,910 B2	2/2019	Shelton, IV et al.
10,101,861 B2	10/2018	Kiyoto	10,194,913 B2	2/2019	Nalagatla et al.
10,105,128 B2	10/2018	Cooper et al.	10,194,976 B2	2/2019	Boudreaux
10,105,136 B2	10/2018	Yates et al.	10,194,992 B2	2/2019	Robinson
10,105,139 B2	10/2018	Yates et al.	10,201,348 B2	2/2019	Scheib et al.
10,105,140 B2	10/2018	Malinouskas et al.	10,201,349 B2	2/2019	Leimbach et al.
10,105,142 B2	10/2018	Baxter, III et al.	10,201,363 B2	2/2019	Shelton, IV

US D914,878 S

10,201,364 B2	2/2019	Leimbach et al.	10,278,703 B2	5/2019	Nativ et al.
10,201,365 B2	2/2019	Boudreaux et al.	10,278,707 B2	5/2019	Thompson et al.
10,201,381 B2	2/2019	Zergiebel et al.	10,278,722 B2	5/2019	Shelton, IV et al.
10,206,605 B2	2/2019	Shelton, IV et al.	10,278,780 B2	5/2019	Shelton, IV
10,206,676 B2	2/2019	Shelton, IV	10,285,694 B2	5/2019	Viola et al.
10,206,677 B2	2/2019	Harris et al.	10,285,695 B2	5/2019	Jaworek et al.
10,206,678 B2	2/2019	Shelton, IV et al.	10,285,699 B2	5/2019	Vendely et al.
10,206,748 B2	2/2019	Burbank	10,285,705 B2	5/2019	Shelton, IV et al.
10,210,244 B1	2/2019	Branavan et al.	10,292,701 B2	5/2019	Scheib et al.
10,211,586 B2	2/2019	Adams et al.	10,292,704 B2	5/2019	Harris et al.
10,213,198 B2	2/2019	Aronhalt et al.	10,292,707 B2	5/2019	Shelton, IV et al.
10,213,201 B2	2/2019	Shelton, IV et al.	10,293,100 B2	5/2019	Shelton, IV et al.
10,213,202 B2	2/2019	Flanagan et al.	10,293,553 B2	5/2019	Racenet et al.
10,213,203 B2	2/2019	Swayze et al.	10,299,787 B2	5/2019	Shelton, IV
10,213,262 B2	2/2019	Shelton, IV et al.	10,299,788 B2	5/2019	Heinrich et al.
D842,328 S	3/2019	Jian et al.	10,299,789 B2	5/2019	Marczyk et al.
10,219,811 B2	3/2019	Haider et al.	10,299,790 B2	5/2019	Beardsley
10,219,832 B2	3/2019	Bagwell et al.	10,299,792 B2	5/2019	Huitema et al.
10,220,522 B2	3/2019	Rockrohr	10,299,817 B2	5/2019	Shelton, IV et al.
10,226,239 B2	3/2019	Nicholas et al.	10,299,818 B2	5/2019	Riva
10,226,249 B2	3/2019	Jaworek et al.	10,299,878 B2	5/2019	Shelton, IV et al.
10,226,250 B2	3/2019	Beckman et al.	D850,617 S	6/2019	Shelton, IV et al.
10,226,251 B2	3/2019	Scheib et al.	D851,676 S	6/2019	Foss et al.
10,226,274 B2	3/2019	Worrell et al.	D851,762 S	6/2019	Shelton, IV et al.
10,231,634 B2	3/2019	Zand et al.	10,307,159 B2	6/2019	Harris et al.
10,231,653 B2	3/2019	Bohm et al.	10,307,160 B2	6/2019	Vendely et al.
10,231,734 B2	3/2019	Thompson et al.	10,307,161 B2	6/2019	Jankowski
10,231,794 B2	3/2019	Shelton, IV et al.	10,307,163 B2	6/2019	Moore et al.
10,238,385 B2	3/2019	Yates et al.	10,307,170 B2	6/2019	Parfett et al.
10,238,386 B2	3/2019	Overmyer et al.	10,307,202 B2	6/2019	Smith et al.
10,238,387 B2	3/2019	Yates et al.	10,314,559 B2	6/2019	Razzaque et al.
10,238,389 B2	3/2019	Yates et al.	10,314,577 B2	6/2019	Laurent et al.
10,238,390 B2	3/2019	Harris et al.	10,314,582 B2	6/2019	Shelton, IV et al.
10,238,391 B2	3/2019	Leimbach et al.	10,314,584 B2	6/2019	Scirica et al.
D844,666 S	4/2019	Espeleta et al.	10,314,587 B2	6/2019	Harris et al.
D844,667 S	4/2019	Espeleta et al.	10,314,588 B2	6/2019	Turner et al.
D845,342 S	4/2019	Espeleta et al.	10,314,589 B2	6/2019	Shelton, IV et al.
D847,199 S	4/2019	Whitmore	10,314,590 B2	6/2019	Shelton, IV et al.
10,244,991 B2	4/2019	Shademan et al.	10,315,566 B2	6/2019	Choi et al.
10,245,027 B2	4/2019	Shelton, IV et al.	10,321,907 B2	6/2019	Shelton, IV et al.
10,245,028 B2	4/2019	Shelton, IV et al.	10,321,909 B2	6/2019	Shelton, IV et al.
10,245,029 B2	4/2019	Hunter et al.	10,321,927 B2	6/2019	Hinman
10,245,030 B2	4/2019	Hunter et al.	10,327,743 B2	6/2019	St. Goar et al.
10,245,032 B2	4/2019	Shelton, IV	10,327,764 B2	6/2019	Harris et al.
10,245,033 B2	4/2019	Overmyer et al.	10,327,765 B2	6/2019	Timm et al.
10,245,034 B2	4/2019	Shelton, IV et al.	10,327,767 B2	6/2019	Shelton, IV et al.
10,245,035 B2	4/2019	Swayze et al.	10,327,769 B2	6/2019	Overmyer et al.
10,245,038 B2	4/2019	Hopkins et al.	10,327,776 B2	6/2019	Harris et al.
10,245,058 B2	4/2019	Omori et al.	10,327,777 B2	6/2019	Harris et al.
10,251,648 B2	4/2019	Harris et al.	D854,032 S	7/2019	Jones et al.
10,251,649 B2	4/2019	Schellin et al.	D854,151 S	7/2019	Shelton, IV et al.
10,251,725 B2	4/2019	Valentine et al.	10,335,144 B2	7/2019	Shelton, IV et al.
10,258,322 B2	4/2019	Fanton et al.	10,335,145 B2	7/2019	Harris et al.
10,258,330 B2	4/2019	Shelton, IV et al.	10,335,147 B2	7/2019	Rector et al.
10,258,331 B2	4/2019	Shelton, IV et al.	10,335,148 B2	7/2019	Shelton, IV et al.
10,258,332 B2	4/2019	Schmid et al.	10,335,149 B2	7/2019	Baxter, III et al.
10,258,333 B2	4/2019	Shelton, IV et al.	10,335,150 B2	7/2019	Shelton, IV
10,258,336 B2	4/2019	Baxter, III et al.	10,335,151 B2	7/2019	Shelton, IV et al.
10,258,418 B2	4/2019	Shelton, IV et al.	10,337,148 B2	7/2019	Rouse et al.
10,264,797 B2	4/2019	Zhang et al.	10,342,533 B2	7/2019	Shelton, IV et al.
10,265,065 B2	4/2019	Shelton, IV et al.	10,342,535 B2	7/2019	Scheib et al.
10,265,067 B2	4/2019	Yates et al.	10,342,541 B2	7/2019	Shelton, IV et al.
10,265,068 B2	4/2019	Harris et al.	10,342,543 B2	7/2019	Shelton, IV et al.
10,265,072 B2	4/2019	Shelton, IV et al.	10,342,623 B2	7/2019	Huelman et al.
10,265,073 B2	4/2019	Scheib et al.	10,349,939 B2	7/2019	Shelton, IV et al.
10,265,074 B2	4/2019	Shelton, IV et al.	10,349,941 B2	7/2019	Marczyk et al.
10,265,090 B2	4/2019	Ingmanson et al.	10,349,963 B2	7/2019	Fiksen et al.
10,271,844 B2	4/2019	Valentine et al.	10,350,016 B2	7/2019	Burbank et al.
10,271,845 B2	4/2019	Shelton, IV	10,357,246 B2	7/2019	Shelton, IV et al.
10,271,846 B2	4/2019	Shelton, IV et al.	10,357,247 B2	7/2019	Shelton, IV et al.
10,271,847 B2	4/2019	Racenet et al.	10,357,248 B2	7/2019	Dalessandro et al.
10,271,849 B2	4/2019	Vendely et al.	10,357,252 B2	7/2019	Harris et al.
10,271,851 B2	4/2019	Shelton, IV et al.	10,363,031 B2	7/2019	Alexander, III et al.
D847,989 S	5/2019	Shelton, IV et al.	10,363,033 B2	7/2019	Timm et al.
D848,473 S	5/2019	Zhu et al.	10,363,036 B2	7/2019	Yates et al.
D849,046 S	5/2019	Kuo et al.	10,363,037 B2	7/2019	Aronhalt et al.
10,278,696 B2	5/2019	Gurumurthy et al.	10,363,045 B2	7/2019	Whitfield et al.
10,278,697 B2	5/2019	Shelton, IV et al.	D855,634 S	8/2019	Kim
10,278,702 B2	5/2019	Shelton, IV et al.	D856,359 S	8/2019	Huang et al.

US D914,878 S

10,368,838 B2	8/2019	Williams et al.	10,441,286 B2	10/2019	Shelton, IV et al.
10,368,861 B2	8/2019	Baxter, III et al.	10,441,345 B2	10/2019	Aldridge et al.
10,368,863 B2	8/2019	Timm et al.	10,441,369 B2	10/2019	Shelton, IV et al.
10,368,864 B2	8/2019	Harris et al.	10,448,948 B2	10/2019	Shelton, IV et al.
10,368,865 B2	8/2019	Harris et al.	10,448,950 B2	10/2019	Shelton, IV et al.
10,368,867 B2	8/2019	Harris et al.	10,448,952 B2	10/2019	Shelton, IV et al.
10,368,892 B2	8/2019	Stulen et al.	10,456,122 B2	10/2019	Koltz et al.
10,376,262 B2	8/2019	Zemlok et al.	10,456,132 B2	10/2019	Gettinger et al.
10,376,263 B2	8/2019	Morgan et al.	10,456,133 B2	10/2019	Yates et al.
10,383,626 B2	8/2019	Soltz	10,456,137 B2	10/2019	Vendely et al.
10,383,628 B2	8/2019	Kang et al.	10,456,140 B2	10/2019	Shelton, IV et al.
10,383,629 B2	8/2019	Ross et al.	D865,796 S	11/2019	Xu et al.
10,383,630 B2	8/2019	Shelton, IV et al.	10,463,367 B2	11/2019	Kostrzewski et al.
10,383,633 B2	8/2019	Shelton, IV et al.	10,463,369 B2	11/2019	Shelton, IV et al.
10,383,634 B2	8/2019	Shelton, IV et al.	10,463,370 B2	11/2019	Yates et al.
10,390,823 B2	8/2019	Shelton, IV et al.	10,463,371 B2	11/2019	Kostrzewski
10,390,825 B2	8/2019	Shelton, IV et al.	10,463,372 B2	11/2019	Shelton, IV et al.
10,390,828 B2	8/2019	Vendely et al.	10,463,373 B2	11/2019	Mozdzierz et al.
10,390,829 B2	8/2019	Eckert et al.	10,463,382 B2	11/2019	Ingmanson et al.
10,390,830 B2	8/2019	Schulz	10,463,383 B2	11/2019	Shelton, IV et al.
10,390,841 B2	8/2019	Shelton, IV et al.	10,463,384 B2	11/2019	Shelton, IV et al.
10,390,897 B2	8/2019	Kostrzewski	10,470,762 B2	11/2019	Leimbach et al.
D860,219 S	9/2019	Rasmussen et al.	10,470,763 B2	11/2019	Yates et al.
D861,035 S	9/2019	Park et al.	10,470,764 B2	11/2019	Baxter, III et al.
10,398,433 B2	9/2019	Boudreaux et al.	10,470,767 B2	11/2019	Gleiman et al.
10,398,434 B2	9/2019	Shelton, IV et al.	10,470,768 B2	11/2019	Harris et al.
10,398,436 B2	9/2019	Shelton, IV et al.	10,470,769 B2	11/2019	Shelton, IV et al.
10,398,460 B2	9/2019	Overmyer	10,471,282 B2	11/2019	Kirk et al.
10,405,854 B2	9/2019	Schmid et al.	10,471,576 B2	11/2019	Totsu
10,405,857 B2	9/2019	Shelton, IV et al.	10,471,607 B2	11/2019	Butt et al.
10,405,859 B2	9/2019	Harris et al.	10,478,181 B2	11/2019	Shelton, IV et al.
10,405,863 B2	9/2019	Wise et al.	10,478,182 B2	11/2019	Taylor
10,405,914 B2	9/2019	Manwaring et al.	10,478,188 B2	11/2019	Harris et al.
10,405,932 B2	9/2019	Overmyer	10,478,189 B2	11/2019	Bear et al.
10,405,937 B2	9/2019	Black et al.	10,478,190 B2	11/2019	Miller et al.
10,413,291 B2	9/2019	Worthington et al.	10,478,207 B2	11/2019	Lathrop
10,413,293 B2	9/2019	Shelton, IV et al.	D869,655 S	12/2019	Shelton, IV et al.
10,413,294 B2	9/2019	Shelton, IV et al.	D870,742 S	12/2019	Cornell
10,413,297 B2	9/2019	Harris et al.	10,499,914 B2 *	12/2019	Huang A61B 17/072
10,413,370 B2	9/2019	Yates et al.	10,508,720 B2	12/2019	Nicholas
10,413,373 B2	9/2019	Yates et al.	10,517,592 B2	12/2019	Shelton, IV et al.
10,420,548 B2	9/2019	Whitman et al.	10,537,351 B2	1/2020	Shelton, IV et al.
10,420,549 B2	9/2019	Yates et al.	10,542,985 B2	1/2020	Zhan et al.
10,420,550 B2	9/2019	Shelton, IV	10,561,474 B2	2/2020	Adams et al.
10,420,552 B2	9/2019	Shelton, IV et al.	D879,808 S	3/2020	Harris et al.
10,420,553 B2	9/2019	Shelton, IV et al.	D879,809 S	3/2020	Harris et al.
10,420,554 B2	9/2019	Collings et al.	10,588,632 B2 *	3/2020	Shelton, IV A61B 17/07207
10,420,555 B2	9/2019	Shelton, IV et al.	10,595,887 B2	3/2020	Shelton, IV et al.
10,420,558 B2	9/2019	Nalagatla et al.	10,595,929 B2	3/2020	Boudreaux et al.
10,420,559 B2	9/2019	Marczyk et al.	10,610,236 B2	4/2020	Baril
10,420,560 B2	9/2019	Shelton, IV et al.	10,625,062 B2	4/2020	Matlock et al.
10,420,561 B2	9/2019	Shelton, IV et al.	10,631,859 B2 *	4/2020	Shelton, IV A61B 17/07207
10,420,577 B2	9/2019	Chowaniec et al.	10,631,860 B2 *	4/2020	Bakos A61B 17/072
D861,707 S	10/2019	Yang	10,695,081 B2	6/2020	Shelton, IV et al.
D862,518 S	10/2019	Niven et al.	D890,784 S	7/2020	Shelton, IV et al.
D863,343 S	10/2019	Mazlish et al.	10,702,266 B2	7/2020	Parihar et al.
D864,388 S	10/2019	Barber	10,722,233 B2	7/2020	Wellman
10,426,463 B2	10/2019	Shelton, IV et al.	10,743,930 B2	8/2020	Nagtegaal
10,426,466 B2	10/2019	Contini et al.	10,751,048 B2	8/2020	Whitman et al.
10,426,467 B2	10/2019	Miller et al.	10,765,442 B2	9/2020	Strobl
10,426,468 B2	10/2019	Contini et al.	10,772,630 B2	9/2020	Wixey
10,426,469 B2	10/2019	Shelton, IV et al.	10,772,651 B2	9/2020	Shelton, IV et al.
10,426,471 B2	10/2019	Shelton, IV et al.	10,779,821 B2	9/2020	Harris et al.
10,426,476 B2	10/2019	Harris et al.	10,786,248 B2	9/2020	Rousseau et al.
10,426,477 B2	10/2019	Harris et al.	10,799,306 B2	10/2020	Robinson et al.
10,426,478 B2	10/2019	Shelton, IV et al.	10,806,451 B2	10/2020	Harris et al.
10,426,481 B2	10/2019	Aronhalt et al.	2001/0000531 A1	4/2001	Casscells et al.
10,433,837 B2	10/2019	Worthington et al.	2001/0025183 A1	9/2001	Shahidi
10,433,839 B2	10/2019	Scheib et al.	2001/0025184 A1	9/2001	Messerly
10,433,840 B2	10/2019	Shelton, IV et al.	2001/0034530 A1	10/2001	Malackowski et al.
10,433,844 B2	10/2019	Shelton, IV et al.	2002/0014510 A1	2/2002	Richter et al.
10,433,845 B2	10/2019	Baxter, III et al.	2002/0022810 A1	2/2002	Urich
10,433,846 B2	10/2019	Vendely et al.	2002/0022836 A1	2/2002	Goble et al.
10,433,849 B2	10/2019	Shelton, IV et al.	2002/0022861 A1	2/2002	Jacobs et al.
10,433,918 B2	10/2019	Shelton, IV et al.	2002/0029032 A1	3/2002	Arkin
10,441,279 B2	10/2019	Shelton, IV et al.	2002/0029036 A1	3/2002	Goble et al.
10,441,280 B2	10/2019	Timm et al.	2002/0042620 A1	4/2002	Julian et al.
10,441,281 B2	10/2019	Shelton, IV et al.	2002/0087048 A1	7/2002	Brock et al.
10,441,285 B2	10/2019	Shelton, IV et al.	2002/0091374 A1	7/2002	Cooper

US D914,878 S

2002/0095175 A1	7/2002	Brock et al.	2004/0158261 A1	8/2004	Vu
2002/0103494 A1	8/2002	Pacey	2004/0164123 A1	8/2004	Racenet et al.
2002/0111624 A1	8/2002	Witt et al.	2004/0166169 A1	8/2004	Malaviya et al.
2002/0116063 A1	8/2002	Giannetti et al.	2004/0167572 A1	8/2004	Roth et al.
2002/0117534 A1	8/2002	Green et al.	2004/0181219 A1	9/2004	Goble et al.
2002/0127265 A1	9/2002	Bowman et al.	2004/0193189 A1	9/2004	Kortenbach et al.
2002/0128633 A1	9/2002	Brock et al.	2004/0197367 A1	10/2004	Rezania et al.
2002/0134811 A1	9/2002	Napier et al.	2004/0199181 A1	10/2004	Knodel et al.
2002/0135474 A1	9/2002	Sylliassen	2004/0204735 A1	10/2004	Shiroff et al.
2002/0143340 A1	10/2002	Kaneko	2004/0218451 A1	11/2004	Said et al.
2002/0151770 A1	10/2002	Noll et al.	2004/0222268 A1	11/2004	Bilotti et al.
2002/0158593 A1	10/2002	Henderson et al.	2004/0225186 A1	11/2004	Horne et al.
2002/0185514 A1	12/2002	Adams et al.	2004/0232201 A1	11/2004	Wenchell et al.
2002/0188170 A1	12/2002	Santamore et al.	2004/0236352 A1	11/2004	Wang et al.
2002/0188287 A1	12/2002	Zvuloni et al.	2004/0243147 A1	12/2004	Lipow
2003/0009193 A1	1/2003	Corsaro	2004/0243151 A1	12/2004	Demmy et al.
2003/0011245 A1	1/2003	Fiebig	2004/0243163 A1	12/2004	Casiano et al.
2003/0012805 A1	1/2003	Chen et al.	2004/0247415 A1	12/2004	Mangone
2003/0040670 A1	2/2003	Govari	2004/0249366 A1	12/2004	Kunz
2003/0045835 A1	3/2003	Anderson et al.	2004/0254455 A1	12/2004	Iddan
2003/0066858 A1	4/2003	Holgersson	2004/0254566 A1	12/2004	Plicchi et al.
2003/0078647 A1	4/2003	Vallana et al.	2004/0254590 A1	12/2004	Hoffman et al.
2003/0083648 A1	5/2003	Wang et al.	2004/0260315 A1	12/2004	Dell et al.
2003/0084983 A1	5/2003	Rangachari et al.	2004/0267310 A1	12/2004	Racenet et al.
2003/0093103 A1	5/2003	Malackowski et al.	2005/0010158 A1	1/2005	Brugger et al.
2003/0094356 A1	5/2003	Waldron	2005/0010213 A1	1/2005	Stad et al.
2003/0096158 A1	5/2003	Takano et al.	2005/0021078 A1	1/2005	Vleugels et al.
2003/0114851 A1	6/2003	Truckai et al.	2005/0032511 A1	2/2005	Malone et al.
2003/0121586 A1	7/2003	Mitra et al.	2005/0033352 A1	2/2005	Zepf et al.
2003/0139741 A1	7/2003	Goble et al.	2005/0051163 A1	3/2005	Deem et al.
2003/0149406 A1	8/2003	Martineau et al.	2005/0054946 A1	3/2005	Krzyzanowski
2003/0153908 A1	8/2003	Goble et al.	2005/0057225 A1	3/2005	Marquet
2003/0153968 A1	8/2003	Geis et al.	2005/0058890 A1	3/2005	Brazell et al.
2003/0163085 A1	8/2003	Tanner et al.	2005/0059997 A1	3/2005	Bauman et al.
2003/0164172 A1	9/2003	Chumas et al.	2005/0070929 A1	3/2005	Dalessandro et al.
2003/0181900 A1	9/2003	Long	2005/0075561 A1	4/2005	Golden
2003/0190584 A1	10/2003	Heasley	2005/0080342 A1	4/2005	Gilreath et al.
2003/0195387 A1	10/2003	Kortenbach et al.	2005/0085693 A1	4/2005	Belson et al.
2003/0205029 A1	11/2003	Chapolini et al.	2005/0090817 A1	4/2005	Phan
2003/0212005 A1	11/2003	Petito et al.	2005/0096683 A1	5/2005	Ellins et al.
2003/0216732 A1	11/2003	Truckai et al.	2005/0116673 A1	6/2005	Carl et al.
2003/0236505 A1	12/2003	Bonadio et al.	2005/0124855 A1	6/2005	Jaffe et al.
2004/0006335 A1	1/2004	Garrison	2005/0125897 A1	6/2005	Wyslucha et al.
2004/0006340 A1	1/2004	Latterell et al.	2005/0129735 A1	6/2005	Cook et al.
2004/0007608 A1	1/2004	Ehrenfels et al.	2005/0130682 A1	6/2005	Takara et al.
2004/0024457 A1	2/2004	Boyce et al.	2005/0131173 A1	6/2005	McDaniel et al.
2004/0028502 A1	2/2004	Cummins	2005/0131211 A1	6/2005	Bayley et al.
2004/0030333 A1	2/2004	Goble	2005/0131390 A1	6/2005	Heinrich et al.
2004/0034357 A1	2/2004	Beane et al.	2005/0131436 A1	6/2005	Johnston et al.
2004/0044295 A1	3/2004	Reinert et al.	2005/0131457 A1	6/2005	Douglas et al.
2004/0044364 A1	3/2004	DeVries et al.	2005/0137454 A1	6/2005	Saadat et al.
2004/0049121 A1	3/2004	Yaron	2005/0137455 A1	6/2005	Ewers et al.
2004/0049172 A1	3/2004	Root et al.	2005/0139636 A1	6/2005	Schwemberger et al.
2004/0059362 A1	3/2004	Knodel et al.	2005/0143759 A1	6/2005	Kelly
2004/0068161 A1	4/2004	Couvillon	2005/0143769 A1	6/2005	White et al.
2004/0068224 A1	4/2004	Couvillon et al.	2005/0145671 A1	7/2005	Viola
2004/0068307 A1	4/2004	Goble	2005/0150928 A1	7/2005	Kameyama et al.
2004/0070369 A1	4/2004	Sakakibara	2005/0154258 A1	7/2005	Tartaglia et al.
2004/0073222 A1	4/2004	Koseki	2005/0154406 A1	7/2005	Bombard et al.
2004/0078037 A1	4/2004	Batchelor et al.	2005/0159778 A1	7/2005	Heinrich et al.
2004/0082952 A1	4/2004	Dycus et al.	2005/0165419 A1	7/2005	Sauer et al.
2004/0085180 A1	5/2004	Juang	2005/0169974 A1	8/2005	Tenerz et al.
2004/0092992 A1	5/2004	Adams et al.	2005/0171522 A1	8/2005	Christopherson
2004/0093024 A1	5/2004	Lousararian et al.	2005/0177176 A1	8/2005	Gerbi et al.
2004/0098040 A1	5/2004	Taniguchi et al.	2005/0177181 A1	8/2005	Kagan et al.
2004/0101822 A1	5/2004	Wiesner et al.	2005/0177249 A1	8/2005	Kladakis et al.
2004/0102783 A1	5/2004	Sutterlin et al.	2005/0182298 A1	8/2005	Ikeda et al.
2004/0108357 A1	6/2004	Milliman et al.	2005/0182443 A1	8/2005	Jonn et al.
2004/0110439 A1	6/2004	Chaikof et al.	2005/0184121 A1	8/2005	Heinrich
2004/0115022 A1	6/2004	Albertson et al.	2005/0186240 A1	8/2005	Ringelsen et al.
2004/0116952 A1	6/2004	Sakurai et al.	2005/0187545 A1	8/2005	Hooven et al.
2004/0119185 A1	6/2004	Chen	2005/0203550 A1	9/2005	Laufer et al.
2004/0122419 A1	6/2004	Neuberger	2005/0209614 A1	9/2005	Fenter et al.
2004/0122423 A1	6/2004	Dycus et al.	2005/0216055 A1	9/2005	Scirica et al.
2004/0133095 A1	7/2004	Dunki-Jacobs et al.	2005/0222587 A1	10/2005	Jinno et al.
2004/0133189 A1	7/2004	Sakurai	2005/0222611 A1	10/2005	Weitkamp
2004/0143297 A1	7/2004	Ramsey	2005/0222616 A1	10/2005	Rethy et al.
2004/0147909 A1	7/2004	Johnston et al.	2005/0222665 A1	10/2005	Aranyi
2004/0153100 A1	8/2004	Ahlberg et al.	2005/0228224 A1	10/2005	Okada et al.

US D914,878 S

Page 36

2005/0228446	A1	10/2005	Mooradian et al.	2007/0027468	A1	2/2007	Wales et al.
2005/0230453	A1	10/2005	Viola	2007/0027551	A1	2/2007	Farnsworth et al.
2005/0240178	A1	10/2005	Morley et al.	2007/0043387	A1	2/2007	Vargas et al.
2005/0245965	A1	11/2005	Orban, III et al.	2007/0049951	A1	3/2007	Menn
2005/0246881	A1	11/2005	Kelly et al.	2007/0049966	A1	3/2007	Bonadio et al.
2005/0251063	A1	11/2005	Basude	2007/0051375	A1	3/2007	Milliman
2005/0256452	A1	11/2005	DeMarchi et al.	2007/0055228	A1	3/2007	Berg et al.
2005/0261676	A1	11/2005	Hall et al.	2007/0073341	A1	3/2007	Smith et al.
2005/0263563	A1	12/2005	Racenet et al.	2007/0073389	A1	3/2007	Bolduc et al.
2005/0267455	A1	12/2005	Eggers et al.	2007/0078328	A1	4/2007	Ozaki et al.
2005/0274034	A1	12/2005	Hayashida et al.	2007/0078484	A1	4/2007	Talarico et al.
2005/0283188	A1	12/2005	Loshakove et al.	2007/0084897	A1	4/2007	Shelton et al.
2005/0283226	A1	12/2005	Haverkost	2007/0088376	A1	4/2007	Zacharias
2006/0008787	A1	1/2006	Hayman et al.	2007/0090788	A1	4/2007	Hansford et al.
2006/0015009	A1	1/2006	Jaffe et al.	2007/0093869	A1	4/2007	Bloom et al.
2006/0020258	A1	1/2006	Strauss et al.	2007/0102472	A1	5/2007	Shelton
2006/0020336	A1	1/2006	Liddicoat	2007/0103437	A1	5/2007	Rosenberg
2006/0025812	A1	2/2006	Shelton	2007/0106113	A1	5/2007	Ravo
2006/0041188	A1	2/2006	Dirusso et al.	2007/0106317	A1	5/2007	Shelton et al.
2006/0047275	A1	3/2006	Goble	2007/0134251	A1	6/2007	Ashkenazi et al.
2006/0049229	A1	3/2006	Milliman et al.	2007/0135686	A1	6/2007	Pruitt et al.
2006/0052824	A1	3/2006	Ransick et al.	2007/0135803	A1	6/2007	Belson
2006/0052825	A1	3/2006	Ransick et al.	2007/0152612	A1	7/2007	Chen et al.
2006/0064086	A1	3/2006	Odom	2007/0155010	A1	7/2007	Farnsworth et al.
2006/0079735	A1	4/2006	Martone et al.	2007/0170225	A1	7/2007	Shelton et al.
2006/0079874	A1	4/2006	Faller et al.	2007/0173687	A1	7/2007	Shima et al.
2006/0079879	A1	4/2006	Faller et al.	2007/0173813	A1	7/2007	Odom
2006/0086032	A1	4/2006	Valencic et al.	2007/0173872	A1	7/2007	Neuenfeldt
2006/0087746	A1	4/2006	Lipow	2007/0175950	A1	8/2007	Shelton et al.
2006/0089535	A1	4/2006	Raz et al.	2007/0175951	A1	8/2007	Shelton et al.
2006/0097699	A1	5/2006	Kamenoff	2007/0175955	A1	8/2007	Shelton et al.
2006/0100643	A1	5/2006	Lauffer et al.	2007/0179477	A1	8/2007	Danger
2006/0100649	A1	5/2006	Hart	2007/0185545	A1	8/2007	Duke
2006/0106369	A1	5/2006	Desai et al.	2007/0187857	A1	8/2007	Riley et al.
2006/0111711	A1	5/2006	Goble	2007/0190110	A1	8/2007	Pameijer et al.
2006/0111723	A1	5/2006	Chapolini et al.	2007/0191868	A1	8/2007	Theroux et al.
2006/0116634	A1	6/2006	Shachar	2007/0194079	A1	8/2007	Hueil et al.
2006/0142772	A1	6/2006	Ralph et al.	2007/0194082	A1	8/2007	Morgan et al.
2006/0144898	A1	7/2006	Bilotti et al.	2007/0197954	A1	8/2007	Keenan
2006/0154546	A1	7/2006	Murphy et al.	2007/0198039	A1	8/2007	Jones et al.
2006/0161050	A1	7/2006	Butler et al.	2007/0203510	A1	8/2007	Bettuchi
2006/0161185	A1	7/2006	Saadat et al.	2007/0207010	A1	9/2007	Caspi
2006/0167471	A1	7/2006	Phillips	2007/0208359	A1	9/2007	Hoffman
2006/0173290	A1	8/2006	Lavallee et al.	2007/0208375	A1	9/2007	Nishizawa et al.
2006/0173470	A1	8/2006	Oray et al.	2007/0213750	A1	9/2007	Weadock
2006/0176031	A1	8/2006	Forman et al.	2007/0225562	A1	9/2007	Spivey et al.
2006/0178556	A1	8/2006	Hasser et al.	2007/0233163	A1	10/2007	Bombard et al.
2006/0180633	A1	8/2006	Emmons	2007/0243227	A1	10/2007	Gertner
2006/0180634	A1	8/2006	Shelton et al.	2007/0244471	A1	10/2007	Malackowski
2006/0185682	A1	8/2006	Marczyk	2007/0244496	A1	10/2007	Hellenkamp
2006/0199999	A1	9/2006	Ikeda et al.	2007/0246505	A1	10/2007	Pace-Florida et al.
2006/0201989	A1	9/2006	Ojeda	2007/0262592	A1	11/2007	Hwang et al.
2006/0206100	A1	9/2006	Eskridge et al.	2007/0275035	A1	11/2007	Herman et al.
2006/0217729	A1	9/2006	Eskridge et al.	2007/0276409	A1	11/2007	Ortiz et al.
2006/0235368	A1	10/2006	Oz	2007/0279011	A1	12/2007	Jones et al.
2006/0241666	A1	10/2006	Briggs et al.	2007/0286892	A1	12/2007	Herzberg et al.
2006/0244460	A1	11/2006	Weaver	2007/0290027	A1	12/2007	Maatta et al.
2006/0252990	A1	11/2006	Kubach	2007/0296286	A1	12/2007	Avenell
2006/0252993	A1	11/2006	Freed et al.	2008/0003196	A1	1/2008	Jonn et al.
2006/0258904	A1	11/2006	Stefanchik et al.	2008/0015598	A1	1/2008	Prommersberger
2006/0259073	A1	11/2006	Miyamoto et al.	2008/0021486	A1	1/2008	Oyola et al.
2006/0261763	A1	11/2006	Lott et al.	2008/0029570	A1	2/2008	Shelton et al.
2006/0263444	A1	11/2006	Ming et al.	2008/0029573	A1	2/2008	Shelton et al.
2006/0264831	A1	11/2006	Skwarek et al.	2008/0029574	A1	2/2008	Shelton et al.
2006/0264929	A1	11/2006	Goble et al.	2008/0029575	A1	2/2008	Shelton et al.
2006/0271042	A1	11/2006	Latterell et al.	2008/0030170	A1	2/2008	Dacquay et al.
2006/0271102	A1	11/2006	Bosshard et al.	2008/0039746	A1	2/2008	Hissong et al.
2006/0282064	A1	12/2006	Shimizu et al.	2008/0042861	A1	2/2008	Dacquay et al.
2006/0284730	A1	12/2006	Schmid et al.	2008/0051833	A1	2/2008	Gramuglia et al.
2006/0287576	A1	12/2006	Tsuji et al.	2008/0064920	A1	3/2008	Bakos et al.
2006/0289602	A1	12/2006	Wales et al.	2008/0064921	A1	3/2008	Larkin et al.
2006/0291981	A1	12/2006	Viola et al.	2008/0065153	A1	3/2008	Allard et al.
2007/0009570	A1	1/2007	Kim et al.	2008/0071328	A1	3/2008	Haubrich et al.
2007/0010702	A1	1/2007	Wang et al.	2008/0077158	A1	3/2008	Haider et al.
2007/0010838	A1	1/2007	Shelton et al.	2008/0078802	A1	4/2008	Hess et al.
2007/0016235	A1	1/2007	Tanaka et al.	2008/0082114	A1	4/2008	McKenna et al.
2007/0018958	A1	1/2007	Tavakoli et al.	2008/0082125	A1	4/2008	Murray et al.
2007/0026039	A1	2/2007	Drumheller et al.	2008/0082126	A1	4/2008	Murray et al.
2007/0026040	A1	2/2007	Crawley et al.	2008/0083807	A1	4/2008	Beardsley et al.

US D914,878 S

Page 37

2008/0085296 A1	4/2008	Powell et al.	2009/0177226 A1	7/2009	Reinprecht et al.
2008/0086078 A1	4/2008	Powell et al.	2009/0181290 A1	7/2009	Baldwin et al.
2008/0091072 A1	4/2008	Omori et al.	2009/0188964 A1	7/2009	Orlov
2008/0108443 A1	5/2008	Jinno et al.	2009/0192534 A1	7/2009	Ortiz et al.
2008/0114250 A1	5/2008	Urbano et al.	2009/0198272 A1	8/2009	Kerver et al.
2008/0125634 A1	5/2008	Ryan et al.	2009/0204108 A1	8/2009	Steffen
2008/0125749 A1	5/2008	Olson	2009/0204109 A1	8/2009	Grove et al.
2008/0128469 A1	6/2008	Dalessandro et al.	2009/0206125 A1	8/2009	Huitema et al.
2008/0129253 A1	6/2008	Shiue et al.	2009/0206126 A1	8/2009	Huitema et al.
2008/0135600 A1	6/2008	Hiranuma et al.	2009/0206131 A1	8/2009	Weisenburgh, II et al.
2008/0140115 A1	6/2008	Stopek	2009/0206133 A1	8/2009	Morgan et al.
2008/0140159 A1	6/2008	Bornhoft et al.	2009/0206137 A1	8/2009	Hall et al.
2008/0149682 A1	6/2008	Uhm	2009/0206139 A1	8/2009	Hall et al.
2008/0154299 A1	6/2008	Livneh	2009/0206141 A1	8/2009	Huitema et al.
2008/0154335 A1	6/2008	Thrope et al.	2009/0206142 A1	8/2009	Huitema et al.
2008/0169328 A1	7/2008	Shelton	2009/0221993 A1	9/2009	Sohi et al.
2008/0169332 A1	7/2008	Shelton et al.	2009/0227834 A1	9/2009	Nakamoto et al.
2008/0169333 A1	7/2008	Shelton et al.	2009/0234273 A1	9/2009	Intoccia et al.
2008/0172087 A1	7/2008	Fuchs et al.	2009/0242610 A1	10/2009	Shelton, IV et al.
2008/0177392 A1	7/2008	Williams et al.	2009/0246873 A1	10/2009	Yamamoto et al.
2008/0190989 A1	8/2008	Crews et al.	2009/0247368 A1	10/2009	Chiang
2008/0196253 A1	8/2008	Ezra et al.	2009/0247901 A1	10/2009	Zimmer
2008/0196419 A1	8/2008	Dube	2009/0248100 A1	10/2009	Vaisnys et al.
2008/0197167 A1	8/2008	Viola et al.	2009/0253959 A1	10/2009	Yoshie et al.
2008/0200755 A1	8/2008	Bakos	2009/0255974 A1	10/2009	Viola
2008/0200762 A1	8/2008	Stokes et al.	2009/0261141 A1	10/2009	Stratton et al.
2008/0200835 A1	8/2008	Monson et al.	2009/0262078 A1	10/2009	Pizzi
2008/0200911 A1	8/2008	Long	2009/0270895 A1	10/2009	Churchill et al.
2008/0200933 A1	8/2008	Bakos et al.	2009/0278406 A1	11/2009	Hoffman
2008/0200934 A1	8/2008	Fox	2009/0290016 A1	11/2009	Suda
2008/0206186 A1	8/2008	Butler et al.	2009/0292283 A1	11/2009	Odom
2008/0234709 A1	9/2008	Houser	2009/0306639 A1	12/2009	Nevo et al.
2008/0242939 A1	10/2008	Johnston	2009/0308907 A1	12/2009	Nalagatla et al.
2008/0249536 A1	10/2008	Stahler et al.	2009/0318557 A1	12/2009	Stockel
2008/0249608 A1	10/2008	Dave	2009/0325859 A1	12/2009	Ameer et al.
2008/0255413 A1	10/2008	Zemlok et al.	2010/0005035 A1	1/2010	Carpenter et al.
2008/0255663 A1	10/2008	Akpek et al.	2010/0012703 A1	1/2010	Calabrese et al.
2008/0262654 A1	10/2008	Omori et al.	2010/0015104 A1	1/2010	Fraser et al.
2008/0269596 A1	10/2008	Revie et al.	2010/0016888 A1	1/2010	Calabrese et al.
2008/0281171 A1	11/2008	Fennell et al.	2010/0017715 A1	1/2010	Balassanian
2008/0281332 A1	11/2008	Taylor	2010/0023024 A1	1/2010	Zeiner et al.
2008/0287944 A1	11/2008	Pearson et al.	2010/0030233 A1	2/2010	Whitman et al.
2008/0293910 A1	11/2008	Kapiamba et al.	2010/0036370 A1	2/2010	Mirel et al.
2008/0294179 A1	11/2008	Balbierz et al.	2010/0051668 A1	3/2010	Milliman et al.
2008/0296346 A1	12/2008	Shelton, IV et al.	2010/0057118 A1	3/2010	Dietz et al.
2008/0297287 A1	12/2008	Shachar et al.	2010/0065604 A1	3/2010	Weng
2008/0298784 A1	12/2008	Kastner	2010/0069942 A1	3/2010	Shelton, IV
2008/0308602 A1	12/2008	Timm et al.	2010/0076483 A1	3/2010	Imuta
2008/0308603 A1	12/2008	Shelton et al.	2010/0076489 A1	3/2010	Stopek et al.
2008/0312686 A1	12/2008	Ellingwood	2010/0081883 A1	4/2010	Murray et al.
2008/0312687 A1	12/2008	Blier	2010/0094340 A1	4/2010	Stopek et al.
2008/0315829 A1	12/2008	Jones et al.	2010/0100123 A1	4/2010	Bennett
2009/0001121 A1	1/2009	Hess et al.	2010/0100124 A1	4/2010	Calabrese et al.
2009/0001130 A1	1/2009	Hess et al.	2010/0116519 A1	5/2010	Gareis
2009/0004455 A1	1/2009	Gravagna et al.	2010/0122339 A1	5/2010	Boccacci
2009/0005809 A1	1/2009	Hess et al.	2010/0133317 A1	6/2010	Shelton, IV et al.
2009/0012534 A1	1/2009	Madhani et al.	2010/0137990 A1	6/2010	Apatsidis et al.
2009/0015195 A1	1/2009	Loth-Krausser	2010/0138659 A1	6/2010	Carmichael et al.
2009/0020958 A1	1/2009	Soul	2010/0145146 A1	6/2010	Melder
2009/0048583 A1	2/2009	Williams et al.	2010/0147921 A1	6/2010	Olson
2009/0048589 A1	2/2009	Takashino et al.	2010/0147922 A1	6/2010	Olson
2009/0076506 A1	3/2009	Baker	2010/0179022 A1	7/2010	Shirokoshi
2009/0078736 A1	3/2009	Van Lue	2010/0180711 A1	7/2010	Kilibarda et al.
2009/0081313 A1	3/2009	Aghion et al.	2010/0191262 A1	7/2010	Harris et al.
2009/0088659 A1	4/2009	Graham et al.	2010/0191292 A1	7/2010	DeMeo et al.
2009/0090763 A1	4/2009	Zemlok et al.	2010/0193566 A1	8/2010	Scheib et al.
2009/0092651 A1	4/2009	Shah et al.	2010/0204717 A1	8/2010	Knodel
2009/0099579 A1	4/2009	Nentwick et al.	2010/0204721 A1	8/2010	Young et al.
2009/0099876 A1	4/2009	Whitman	2010/0217281 A1	8/2010	Matsuoka et al.
2009/0110533 A1	4/2009	Jinno	2010/0222901 A1	9/2010	Swayze et al.
2009/0112234 A1	4/2009	Crainich et al.	2010/0228250 A1	9/2010	Brogna
2009/0118762 A1	5/2009	Crainch et al.	2010/0241137 A1	9/2010	Doyle et al.
2009/0119011 A1	5/2009	Kondo et al.	2010/0245102 A1	9/2010	Yokoi
2009/0131819 A1	5/2009	Ritchie et al.	2010/0249497 A1	9/2010	Peine et al.
2009/0132400 A1	5/2009	Conway	2010/0249947 A1	9/2010	Lesh et al.
2009/0143855 A1	6/2009	Weber et al.	2010/0256675 A1	10/2010	Romans
2009/0149871 A9	6/2009	Kagan et al.	2010/0258327 A1	10/2010	Esenwein et al.
2009/0171147 A1	7/2009	Lee et al.	2010/0267662 A1	10/2010	Fielder et al.
2009/0177218 A1	7/2009	Young et al.	2010/0274160 A1	10/2010	Yachi et al.

US D914,878 S

2010/0292540 A1	11/2010	Hess et al.	2012/0109186 A1	5/2012	Parrott et al.
2010/0298636 A1	11/2010	Castro et al.	2012/0116261 A1	5/2012	Mumaw et al.
2010/0301097 A1	12/2010	Scirica et al.	2012/0116262 A1	5/2012	Houser et al.
2010/0310623 A1	12/2010	Laurencin et al.	2012/0116265 A1	5/2012	Houser et al.
2010/0312261 A1	12/2010	Suzuki et al.	2012/0116266 A1	5/2012	Houser et al.
2010/0318085 A1	12/2010	Austin et al.	2012/0116381 A1	5/2012	Houser et al.
2010/0331856 A1	12/2010	Carlson et al.	2012/0118595 A1	5/2012	Pellenc
2011/0006101 A1	1/2011	Hall et al.	2012/0123463 A1	5/2012	Jacobs
2011/0011916 A1	1/2011	Levine	2012/0125792 A1	5/2012	Cassivi
2011/0016960 A1	1/2011	Debrailly	2012/0130217 A1	5/2012	Kauphusman et al.
2011/0021871 A1	1/2011	Berkelaar	2012/0132286 A1	5/2012	Lim et al.
2011/0022032 A1	1/2011	Zemlok et al.	2012/0171539 A1	7/2012	Rejman et al.
2011/0024477 A1	2/2011	Hall	2012/0175398 A1	7/2012	Sandborn et al.
2011/0024478 A1	2/2011	Shelton, IV	2012/0197272 A1	8/2012	Oray et al.
2011/0025311 A1	2/2011	Chauvin et al.	2012/0211542 A1	8/2012	Racenet
2011/0029270 A1	2/2011	Mueglitz	2012/0220990 A1	8/2012	McKenzie et al.
2011/0036891 A1	2/2011	Zemlok et al.	2012/0234895 A1	9/2012	O'Connor et al.
2011/0046667 A1	2/2011	Culligan et al.	2012/0234897 A1	9/2012	Shelton, IV et al.
2011/0052660 A1	3/2011	Yang et al.	2012/0239068 A1	9/2012	Morris et al.
2011/0060363 A1	3/2011	Hess et al.	2012/0248169 A1	10/2012	Widenhouse et al.
2011/0066156 A1	3/2011	McGahan et al.	2012/0251861 A1	10/2012	Liang et al.
2011/0082538 A1	4/2011	Dahlgren et al.	2012/0253328 A1	10/2012	Cunningham et al.
2011/0087276 A1	4/2011	Bedi et al.	2012/0271327 A1	10/2012	West et al.
2011/0088921 A1	4/2011	Forgues et al.	2012/0283707 A1	11/2012	Giordano et al.
2011/0091515 A1	4/2011	Zilberman et al.	2012/0289811 A1	11/2012	Viola et al.
2011/0095064 A1	4/2011	Taylor et al.	2012/0289979 A1	11/2012	Eskaros et al.
2011/0101069 A1	5/2011	Bombard et al.	2012/0292367 A1	11/2012	Morgan et al.
2011/0101794 A1	5/2011	Schroeder et al.	2012/0296342 A1	11/2012	Haglund Wendelschafer
2011/0112517 A1	5/2011	Peine et al.	2012/0298722 A1	11/2012	Hess et al.
2011/0112530 A1	5/2011	Keller	2012/0301498 A1	11/2012	Altreuter et al.
2011/0114697 A1	5/2011	Baxter, III et al.	2012/0303002 A1	11/2012	Chowaniec et al.
2011/0121049 A1	5/2011	Malinouskas et al.	2012/0330329 A1	12/2012	Harris et al.
2011/0125149 A1	5/2011	Ei-Galley et al.	2013/0006227 A1	1/2013	Takashino
2011/0125176 A1	5/2011	Yates et al.	2013/0008937 A1	1/2013	Viola
2011/0127945 A1	6/2011	Yoneda	2013/0012983 A1	1/2013	Kleyman
2011/0129706 A1	6/2011	Takahashi et al.	2013/0018400 A1	1/2013	Milton et al.
2011/0144764 A1	6/2011	Bagga et al.	2013/0020375 A1	1/2013	Shelton, IV et al.
2011/0147433 A1	6/2011	Shelton, IV et al.	2013/0020376 A1	1/2013	Shelton, IV et al.
2011/0160725 A1	6/2011	Kabaya et al.	2013/0023861 A1	1/2013	Shelton, IV et al.
2011/0163146 A1	7/2011	Ortiz et al.	2013/0023910 A1	1/2013	Solomon et al.
2011/0172495 A1	7/2011	Armstrong	2013/0026208 A1	1/2013	Shelton, IV et al.
2011/0174861 A1	7/2011	Shelton, IV et al.	2013/0026210 A1	1/2013	Shelton, IV et al.
2011/0192882 A1	8/2011	Hess et al.	2013/0030462 A1	1/2013	Keating et al.
2011/0199225 A1	8/2011	Touchberry et al.	2013/0041292 A1	2/2013	Cunningham
2011/0218400 A1	9/2011	Ma et al.	2013/0057162 A1	3/2013	Pollischansky
2011/0218550 A1	9/2011	Ma	2013/0068816 A1	3/2013	Mandakolathur Vasudevan et al.
2011/0225105 A1	9/2011	Scholer et al.	2013/0087597 A1	4/2013	Shelton, IV et al.
2011/0230713 A1	9/2011	Kleemann et al.	2013/0090534 A1	4/2013	Burns et al.
2011/0238044 A1	9/2011	Main et al.	2013/0096568 A1	4/2013	Justis
2011/0241597 A1	10/2011	Zhu et al.	2013/0098970 A1	4/2013	Racenet et al.
2011/0256266 A1	10/2011	Orme et al.	2013/0105552 A1	5/2013	Weir et al.
2011/0271186 A1	11/2011	Owens	2013/0106352 A1	5/2013	Nagamine
2011/0275901 A1	11/2011	Shelton, IV	2013/0116669 A1	5/2013	Shelton, IV et al.
2011/0276083 A1	11/2011	Shelton, IV et al.	2013/0123816 A1	5/2013	Hodgkinson et al.
2011/0278343 A1	11/2011	Knodel et al.	2013/0126202 A1	5/2013	Oomori et al.
2011/0279268 A1	11/2011	Konishi et al.	2013/0131476 A1	5/2013	Siu et al.
2011/0290856 A1	12/2011	Shelton, IV et al.	2013/0131651 A1	5/2013	Strobl et al.
2011/0290858 A1	12/2011	Whitman et al.	2013/0136969 A1	5/2013	Yasui et al.
2011/0293690 A1	12/2011	Griffin et al.	2013/0153641 A1	6/2013	Shelton, IV et al.
2011/0295295 A1	12/2011	Shelton, IV et al.	2013/0158390 A1	6/2013	Tan et al.
2011/0313894 A1	12/2011	Dye et al.	2013/0162198 A1	6/2013	Yokota et al.
2011/0315413 A1	12/2011	Fisher et al.	2013/0169217 A1	7/2013	Watanabe et al.
2012/0004636 A1	1/2012	Lo	2013/0172878 A1	7/2013	Smith
2012/0007442 A1	1/2012	Rhodes et al.	2013/0175317 A1	7/2013	Yates et al.
2012/0016239 A1	1/2012	Barthe et al.	2013/0211244 A1	8/2013	Nathaniel
2012/0016413 A1	1/2012	Timm et al.	2013/0214025 A1	8/2013	Zemlok et al.
2012/0016467 A1	1/2012	Chen et al.	2013/0215449 A1	8/2013	Yamasaki
2012/0029272 A1	2/2012	Shelton, IV et al.	2013/0233906 A1	9/2013	Hess et al.
2012/0033360 A1	2/2012	Hsu	2013/0238021 A1	9/2013	Gross et al.
2012/0059286 A1	3/2012	Hastings et al.	2013/0248578 A1	9/2013	Arteaga Gonzalez
2012/0064483 A1	3/2012	Lint et al.	2013/0253480 A1	9/2013	Kimball et al.
2012/0074200 A1	3/2012	Schmid et al.	2013/0256373 A1	10/2013	Schmid et al.
2012/0078244 A1	3/2012	Worrell et al.	2013/0256380 A1	10/2013	Schmid et al.
2012/0080336 A1	4/2012	Shelton, IV et al.	2013/0267978 A1	10/2013	Trissel
2012/0080344 A1	4/2012	Shelton, IV	2013/0270322 A1	10/2013	Scheib et al.
2012/0080478 A1	4/2012	Morgan et al.	2013/0277410 A1	10/2013	Fernandez et al.
2012/0080498 A1	4/2012	Shelton, IV et al.	2013/0306704 A1	11/2013	Balbierz et al.
2012/0086276 A1	4/2012	Sawyers	2013/0317753 A1	11/2013	Kamen et al.
2012/0095458 A1	4/2012	Cybulski et al.	2013/0324982 A1	12/2013	Smith et al.

US D914,878 S

2013/0327552	A1	12/2013	Lovell et al.	2015/0060518	A1	3/2015	Shelton, IV et al.
2013/0333910	A1	12/2013	Tanimoto et al.	2015/0060519	A1	3/2015	Shelton, IV et al.
2013/0334280	A1	12/2013	Krehel et al.	2015/0060520	A1	3/2015	Shelton, IV et al.
2013/0334283	A1	12/2013	Swayze et al.	2015/0060521	A1	3/2015	Weisenburgh, II et al.
2013/0334285	A1	12/2013	Swayze et al.	2015/0066000	A1	3/2015	An et al.
2013/0341374	A1	12/2013	Shelton, IV et al.	2015/0076208	A1	3/2015	Shelton, IV
2014/0001231	A1	1/2014	Shelton, IV et al.	2015/0076209	A1	3/2015	Shelton, IV et al.
2014/0001234	A1	1/2014	Shelton, IV et al.	2015/0076210	A1	3/2015	Shelton, IV et al.
2014/0005640	A1	1/2014	Shelton, IV et al.	2015/0076211	A1	3/2015	Irka et al.
2014/0005678	A1	1/2014	Shelton, IV et al.	2015/0076212	A1	3/2015	Shelton, IV
2014/0005702	A1	1/2014	Timm et al.	2015/0080868	A1	3/2015	Kerr
2014/0005718	A1	1/2014	Shelton, IV et al.	2015/0083781	A1	3/2015	Giordano et al.
2014/0012289	A1	1/2014	Snow et al.	2015/0083782	A1	3/2015	Scheib et al.
2014/0012299	A1	1/2014	Stoddard et al.	2015/0088127	A1	3/2015	Craig et al.
2014/0014704	A1	1/2014	Onukuri et al.	2015/0088547	A1	3/2015	Balram et al.
2014/0014705	A1	1/2014	Baxter, III	2015/0090760	A1	4/2015	Giordano et al.
2014/0014707	A1	1/2014	Onukuri et al.	2015/0090761	A1	4/2015	Giordano et al.
2014/0018832	A1	1/2014	Shelton, IV	2015/0090762	A1	4/2015	Giordano et al.
2014/0039549	A1	2/2014	Belsky et al.	2015/0122870	A1	5/2015	Zemlok et al.
2014/0048580	A1	2/2014	Merchant et al.	2015/0127021	A1	5/2015	Harris et al.
2014/0081176	A1	3/2014	Hassan	2015/0134077	A1	5/2015	Shelton, IV et al.
2014/0094681	A1	4/2014	Valentine et al.	2015/0150620	A1	6/2015	Miyamoto et al.
2014/0100558	A1	4/2014	Schmitz et al.	2015/0173749	A1	6/2015	Shelton, IV et al.
2014/0107640	A1	4/2014	Yates et al.	2015/0173756	A1	6/2015	Baxter, III et al.
2014/0115229	A1	4/2014	Kothamasu et al.	2015/0173789	A1	6/2015	Baxter, III et al.
2014/0131418	A1	5/2014	Kostrzewski	2015/0196295	A1	7/2015	Shelton, IV et al.
2014/0135832	A1	5/2014	Park et al.	2015/0196296	A1	7/2015	Swayze et al.
2014/0151433	A1	6/2014	Shelton, IV et al.	2015/0196299	A1	7/2015	Swayze et al.
2014/0158747	A1	6/2014	Measamer et al.	2015/0201918	A1	7/2015	Kumar et al.
2014/0166723	A1	6/2014	Beardsley et al.	2015/0201932	A1	7/2015	Swayze et al.
2014/0166724	A1	6/2014	Schellin et al.	2015/0201936	A1	7/2015	Swayze et al.
2014/0166725	A1	6/2014	Schellin et al.	2015/0201937	A1	7/2015	Swayze et al.
2014/0166726	A1	6/2014	Schellin et al.	2015/0201938	A1	7/2015	Swayze et al.
2014/0175147	A1	6/2014	Manoux et al.	2015/0201939	A1	7/2015	Swayze et al.
2014/0175150	A1	6/2014	Shelton, IV et al.	2015/0201940	A1	7/2015	Swayze et al.
2014/0175152	A1	6/2014	Hess et al.	2015/0201941	A1	7/2015	Swayze et al.
2014/0181710	A1	6/2014	Baalu et al.	2015/0209045	A1	7/2015	Hodgkinson et al.
2014/0188091	A1	7/2014	Vidal et al.	2015/0222212	A1	8/2015	Iwata
2014/0188159	A1	7/2014	Steege	2015/0223868	A1	8/2015	Brandt et al.
2014/0207124	A1	7/2014	Aldridge et al.	2015/0230697	A1	8/2015	Phee et al.
2014/0207125	A1	7/2014	Applegate et al.	2015/0231409	A1	8/2015	Racenet et al.
2014/0209658	A1	7/2014	Skalla et al.	2015/0238118	A1	8/2015	Legassey et al.
2014/0213848	A1	7/2014	Moskowitz et al.	2015/0272557	A1	10/2015	Overmyer et al.
2014/0224857	A1	8/2014	Schmid	2015/0272571	A1	10/2015	Leimbach et al.
2014/0228632	A1	8/2014	Sholev et al.	2015/0272580	A1	10/2015	Leimbach et al.
2014/0228867	A1	8/2014	Thomas et al.	2015/0272582	A1	10/2015	Leimbach et al.
2014/0239047	A1	8/2014	Hodgkinson et al.	2015/0297200	A1	10/2015	Fitzsimmons et al.
2014/0243865	A1	8/2014	Swayze et al.	2015/0297222	A1	10/2015	Huitema et al.
2014/0246475	A1	9/2014	Hall et al.	2015/0297223	A1	10/2015	Huitema et al.
2014/0248167	A1	9/2014	Sugimoto et al.	2015/0297225	A1	10/2015	Huitema et al.
2014/0249557	A1	9/2014	Koch, Jr. et al.	2015/0297228	A1	10/2015	Huitema et al.
2014/0249573	A1	9/2014	Arav	2015/0297229	A1	10/2015	Schellin et al.
2014/0252061	A1	9/2014	Estrella et al.	2015/0297233	A1	10/2015	Huitema et al.
2014/0263541	A1	9/2014	Leimbach et al.	2015/0297234	A1	10/2015	Schellin et al.
2014/0263552	A1	9/2014	Hall et al.	2015/0302539	A1	10/2015	Mazar et al.
2014/0263558	A1	9/2014	Hausen et al.	2015/0303417	A1	10/2015	Koeder et al.
2014/0276730	A1	9/2014	Boudreaux et al.	2015/0313594	A1	11/2015	Shelton, IV et al.
2014/0284371	A1	9/2014	Morgan et al.	2015/0324317	A1	11/2015	Collins et al.
2014/0288460	A1	9/2014	Ouyang et al.	2015/0327864	A1	11/2015	Hodgkinson et al.
2014/0291379	A1	10/2014	Schellin et al.	2015/0336249	A1	11/2015	Iwata et al.
2014/0291383	A1	10/2014	Spivey et al.	2015/0352699	A1	12/2015	Sakai et al.
2014/0299648	A1	10/2014	Shelton, IV et al.	2015/0366585	A1	12/2015	Lemay et al.
2014/0303645	A1	10/2014	Morgan et al.	2015/0372265	A1	12/2015	Morisaku et al.
2014/0303660	A1	10/2014	Boyden et al.	2015/0374369	A1	12/2015	Yates et al.
2014/0330161	A1	11/2014	Swayze et al.	2015/0374371	A1	12/2015	Richard et al.
2014/0330298	A1	11/2014	Arshonsky et al.	2015/0374372	A1	12/2015	Zergiebel et al.
2014/0330579	A1	11/2014	Cashman et al.	2015/0374378	A1	12/2015	Giordano et al.
2014/0367445	A1	12/2014	Ingmanson et al.	2016/0000430	A1	1/2016	Ming et al.
2014/0374130	A1	12/2014	Nakamura et al.	2016/0000431	A1	1/2016	Giordano et al.
2014/0378950	A1	12/2014	Chiu	2016/0000437	A1	1/2016	Giordano et al.
2015/0002089	A1	1/2015	Rejman et al.	2016/0000438	A1	1/2016	Swayze et al.
2015/0008248	A1	1/2015	Giordano et al.	2016/0000442	A1	1/2016	Shelton, IV
2015/0025549	A1	1/2015	Kilroy et al.	2016/0000452	A1	1/2016	Yates et al.
2015/0038961	A1	2/2015	Clark et al.	2016/0000453	A1	1/2016	Yates et al.
2015/0053737	A1	2/2015	Leimbach et al.	2016/0023342	A1	1/2016	Koenig et al.
2015/0053742	A1	2/2015	Shelton, IV et al.	2016/0030042	A1	2/2016	Heinrich et al.
2015/0053743	A1	2/2015	Yates et al.	2016/0051316	A1	2/2016	Boudreaux
2015/0053746	A1	2/2015	Shelton, IV et al.	2016/0058443	A1	3/2016	Yates et al.
2015/0053748	A1	2/2015	Yates et al.	2016/0066815	A1	3/2016	Mei et al.

US D914,878 S

2016/0066913	A1	3/2016	Swayze et al.		2017/0055819	A1	3/2017	Hansen et al.
2016/0069449	A1	3/2016	Kanai et al.		2017/0055986	A1	3/2017	Harris et al.
2016/0074040	A1	3/2016	Widenhouse et al.		2017/0055999	A1	3/2017	Baxter, III et al.
2016/0074103	A1	3/2016	Sartor		2017/0056000	A1	3/2017	Nalagatla et al.
2016/0082161	A1	3/2016	Zilberman et al.		2017/0056002	A1	3/2017	Nalagatla et al.
2016/0089137	A1	3/2016	Hess et al.		2017/0056005	A1	3/2017	Shelton, IV et al.
2016/0089198	A1	3/2016	Arya et al.		2017/0079642	A1	3/2017	Overmyer et al.
2016/0095585	A1	4/2016	Zergiebel et al.		2017/0086827	A1	3/2017	Vendely et al.
2016/0106431	A1	4/2016	Shelton, IV et al.		2017/0086829	A1	3/2017	Vendely et al.
2016/0113653	A1	4/2016	Zingman		2017/0086830	A1	3/2017	Yates et al.
2016/0120544	A1	5/2016	Shelton, IV et al.		2017/0086831	A1	3/2017	Shelton, IV et al.
2016/0120545	A1	5/2016	Shelton, IV et al.		2017/0086832	A1	3/2017	Harris et al.
2016/0120594	A1	5/2016	Privitera		2017/0086838	A1	3/2017	Harris et al.
2016/0128694	A1*	5/2016	Baxter, III	A61B 17/105 227/178.1	2017/0086842	A1	3/2017	Shelton, IV et al.
					2017/0086843	A1	3/2017	Vendely et al.
2016/0135835	A1	5/2016	Onuma		2017/0086844	A1	3/2017	Vendely et al.
2016/0166248	A1	6/2016	Deville et al.		2017/0086930	A1	3/2017	Thompson et al.
2016/0166256	A1	6/2016	Baxter, III et al.		2017/0095253	A1*	4/2017	Aranyi A61B 17/105
2016/0174974	A1	6/2016	Schmid et al.		2017/0105733	A1	4/2017	Scheib et al.
2016/0183939	A1	6/2016	Shelton, IV et al.		2017/0105782	A1*	4/2017	Scheib A61B 18/12
2016/0183943	A1	6/2016	Shelton, IV		2017/0119388	A1	5/2017	Kostrzewski
2016/0183944	A1	6/2016	Swensgard et al.		2017/0119390	A1	5/2017	Schellin et al.
2016/0192916	A1	7/2016	Shelton, IV et al.		2017/0119397	A1	5/2017	Harris et al.
2016/0192917	A1	7/2016	Shelton, IV et al.		2017/0143335	A1	5/2017	Gupta et al.
2016/0192918	A1	7/2016	Shelton, IV et al.		2017/0150965	A1	6/2017	Williams
2016/0192960	A1	7/2016	Bueno et al.		2017/0172382	A1	6/2017	Nir et al.
2016/0192977	A1	7/2016	Manwaring et al.		2017/0172550	A1	6/2017	Mukherjee et al.
2016/0199063	A1	7/2016	Mandakolathur Vasudevan et al.		2017/0172662	A1	6/2017	Panescu et al.
2016/0199089	A1	7/2016	Hess et al.		2017/0172672	A1	6/2017	Bailey et al.
2016/0199956	A1	7/2016	Shelton, IV et al.		2017/0182211	A1	6/2017	Raxworthy et al.
2016/0206310	A1	7/2016	Shelton, IV		2017/0196556	A1	7/2017	Shah et al.
2016/0206314	A1	7/2016	Scheib et al.		2017/0196558	A1	7/2017	Morgan et al.
2016/0235404	A1	8/2016	Shelton, IV		2017/0196561	A1	7/2017	Shelton, IV et al.
2016/0235409	A1	8/2016	Shelton, IV et al.		2017/0196562	A1	7/2017	Shelton, IV et al.
2016/0235467	A1	8/2016	Godara et al.		2017/0196637	A1	7/2017	Shelton, IV et al.
2016/0235494	A1	8/2016	Shelton, IV et al.		2017/0196648	A1	7/2017	Ward et al.
2016/0242782	A1	8/2016	Shelton, IV et al.		2017/0196649	A1	7/2017	Yates et al.
2016/0242783	A1	8/2016	Shelton, IV et al.		2017/0202571	A1	7/2017	Shelton, IV et al.
2016/02429910	A1	9/2016	Shelton, IV et al.		2017/0202596	A1	7/2017	Shelton, IV et al.
2016/0249922	A1	9/2016	Morgan et al.		2017/0202770	A1	7/2017	Friedrich et al.
2016/0256071	A1	9/2016	Shelton, IV et al.		2017/0209145	A1	7/2017	Swayze et al.
2016/0256154	A1	9/2016	Shelton, IV et al.		2017/0209146	A1	7/2017	Yates et al.
2016/0256159	A1	9/2016	Pinjala et al.		2017/0209226	A1	7/2017	Overmyer et al.
2016/0256160	A1	9/2016	Shelton, IV et al.		2017/0215881	A1	8/2017	Shelton, IV et al.
2016/0256229	A1	9/2016	Morgan et al.		2017/0215943	A1	8/2017	Allen, IV
2016/0262745	A1	9/2016	Morgan et al.		2017/0224331	A1	8/2017	Worthington et al.
2016/0262746	A1	9/2016	Shelton, IV et al.		2017/0224332	A1	8/2017	Hunter et al.
2016/0262921	A1	9/2016	Balbierz et al.		2017/0224334	A1	8/2017	Worthington et al.
2016/0270780	A1	9/2016	Hall et al.		2017/0224335	A1	8/2017	Weaner et al.
2016/0278765	A1	9/2016	Shelton, IV et al.		2017/0224339	A1	8/2017	Huang et al.
2016/0278771	A1	9/2016	Shelton, IV et al.		2017/0224343	A1*	8/2017	Baxter, III A61B 17/072
2016/0278777	A1*	9/2016	Shelton, IV	A61B 17/105	2017/0231627	A1	8/2017	Shelton, IV et al.
2016/0287265	A1	10/2016	Macdonald et al.		2017/0231628	A1	8/2017	Shelton, IV et al.
2016/0287279	A1	10/2016	Bovay et al.		2017/0238928	A1	8/2017	Morgan et al.
2016/0310143	A1	10/2016	Bettuchi		2017/0238929	A1	8/2017	Yates et al.
2016/0314716	A1	10/2016	Grubbs		2017/0238962	A1	8/2017	Hansen et al.
2016/0345976	A1	12/2016	Gonzalez et al.		2017/0245854	A1	8/2017	Zemlok et al.
2016/0346034	A1	12/2016	Arya et al.		2017/0245952	A1	8/2017	Shelton, IV et al.
2016/0354088	A1	12/2016	Cabrera et al.		2017/0249431	A1	8/2017	Shelton, IV et al.
2016/0367122	A1	12/2016	Ichimura et al.		2017/0258469	A1	9/2017	Shelton, IV et al.
2016/0374675	A1	12/2016	Shelton, IV et al.		2017/0262110	A1	9/2017	Polishchuk et al.
2016/0374678	A1	12/2016	Becerra et al.		2017/0265774	A1	9/2017	Johnson et al.
2017/0000553	A1	1/2017	Wiener et al.		2017/0265856	A1	9/2017	Shelton, IV et al.
2017/0007236	A1	1/2017	Shelton, IV et al.		2017/0281155	A1	10/2017	Shelton, IV et al.
2017/0007237	A1	1/2017	Yates et al.		2017/0281164	A1	10/2017	Harris et al.
2017/0007243	A1	1/2017	Shelton, IV et al.		2017/0281166	A1	10/2017	Morgan et al.
2017/0007244	A1	1/2017	Shelton, IV et al.		2017/0281167	A1	10/2017	Shelton, IV et al.
2017/0007245	A1	1/2017	Shelton, IV et al.		2017/0281169	A1	10/2017	Harris et al.
2017/0007247	A1	1/2017	Shelton, IV et al.		2017/0281171	A1	10/2017	Shelton, IV et al.
2017/0007248	A1	1/2017	Shelton, IV et al.		2017/0281173	A1	10/2017	Shelton, IV et al.
2017/0007249	A1	1/2017	Shelton, IV et al.		2017/0281174	A1	10/2017	Harris et al.
2017/0007250	A1	1/2017	Shelton, IV et al.		2017/0281183	A1	10/2017	Miller et al.
2017/0007347	A1	1/2017	Jaworek et al.		2017/0281184	A1	10/2017	Shelton, IV et al.
2017/0014125	A1	1/2017	Shelton, IV et al.		2017/0281186	A1	10/2017	Shelton, IV et al.
2017/0027572	A1	2/2017	Nalagatla et al.		2017/0281187	A1	10/2017	Shelton, IV et al.
2017/0027573	A1	2/2017	Nalagatla et al.		2017/0281189	A1	10/2017	Nalagatla et al.
2017/0049444	A1	2/2017	Schellin et al.		2017/0290584	A1	10/2017	Jasemian et al.
2017/0049447	A1	2/2017	Barton et al.		2017/0290585	A1	10/2017	Shelton, IV et al.
2017/0049448	A1	2/2017	Widenhouse et al.		2017/0296169	A1	10/2017	Yates et al.

US D914,878 S

2017/0296173	A1	10/2017	Shelton, IV et al.	2018/0125488	A1	5/2018	Morgan et al.
2017/0296177	A1	10/2017	Harris et al.	2018/0125489	A1	5/2018	Leimbach et al.
2017/0296179	A1	10/2017	Shelton, IV et al.	2018/0125590	A1	5/2018	Giordano et al.
2017/0296185	A1	10/2017	Swensgard et al.	2018/0125594	A1	5/2018	Beardsley
2017/0296213	A1	10/2017	Swensgard et al.	2018/0126504	A1	5/2018	Shelton, IV et al.
2017/0303924	A1*	10/2017	Scheib A61B 17/068	2018/0132845	A1	5/2018	Schmid et al.
2017/0303952	A1*	10/2017	Nativ A61B 17/07207	2018/0132849	A1	5/2018	Miller et al.
2017/0311944	A1	11/2017	Morgan et al.	2018/0132850	A1	5/2018	Leimbach et al.
2017/0311949	A1	11/2017	Shelton, IV	2018/0132851	A1	5/2018	Hall et al.
2017/0312041	A1	11/2017	Giordano et al.	2018/0132926	A1	5/2018	Asher et al.
2017/0312042	A1	11/2017	Giordano et al.	2018/0132952	A1	5/2018	Spivey et al.
2017/0319201	A1	11/2017	Morgan et al.	2018/0133856	A1	5/2018	Shelton, IV et al.
2017/0319207	A1	11/2017	Shelton, IV et al.	2018/0140299	A1	5/2018	Weaner et al.
2017/0319209	A1	11/2017	Morgan et al.	2018/0140368	A1	5/2018	Shelton, IV et al.
2017/0325813	A1	11/2017	Aranyi et al.	2018/0146960	A1	5/2018	Shelton, IV et al.
2017/0333034	A1	11/2017	Morgan et al.	2018/0150153	A1	5/2018	Yoon et al.
2017/0333035	A1	11/2017	Morgan et al.	2018/0153542	A1	6/2018	Shelton, IV et al.
2017/0333070	A1	11/2017	Laurent et al.	2018/0161034	A1	6/2018	Scheib et al.
2017/0348010	A1	12/2017	Chiang	2018/0168575	A1	6/2018	Simms et al.
2017/0348043	A1	12/2017	Wang et al.	2018/0168576	A1	6/2018	Hunter et al.
2017/0354413	A1	12/2017	Chen et al.	2018/0168577	A1	6/2018	Aronhalt et al.
2017/0354415	A1	12/2017	Casasanta, Jr. et al.	2018/0168578	A1	6/2018	Aronhalt et al.
2017/0358052	A1	12/2017	Yuan	2018/0168579	A1	6/2018	Aronhalt et al.
2017/0360439	A1	12/2017	Chen et al.	2018/0168580	A1	6/2018	Hunter et al.
2017/0360441	A1	12/2017	Sgroi	2018/0168581	A1	6/2018	Hunter et al.
2017/0360442	A1	12/2017	Shelton, IV et al.	2018/0168582	A1	6/2018	Swayze et al.
2017/0364183	A1	12/2017	Xiao	2018/0168583	A1	6/2018	Hunter et al.
2017/0367695	A1	12/2017	Shelton, IV et al.	2018/0168584	A1	6/2018	Harris et al.
2017/0367696	A1	12/2017	Shelton, IV et al.	2018/0168585	A1	6/2018	Shelton, IV et al.
2017/0367697	A1	12/2017	Shelton, IV et al.	2018/0168586	A1	6/2018	Shelton, IV et al.
2017/0367698	A1	12/2017	Shelton, IV et al.	2018/0168589	A1	6/2018	Swayze et al.
2017/0367699	A1	12/2017	Shelton, IV et al.	2018/0168590	A1	6/2018	Overmyer et al.
2017/0367700	A1	12/2017	Leimbach et al.	2018/0168591	A1	6/2018	Swayze et al.
2017/0367991	A1	12/2017	Widenhouse et al.	2018/0168592	A1	6/2018	Overmyer et al.
2018/0000483	A1	1/2018	Leimbach et al.	2018/0168593	A1	6/2018	Overmyer et al.
2018/0000545	A1	1/2018	Giordano et al.	2018/0168594	A1	6/2018	Shelton, IV et al.
2018/0008270	A1	1/2018	Moore et al.	2018/0168595	A1	6/2018	Overmyer et al.
2018/0008271	A1	1/2018	Moore et al.	2018/0168596	A1	6/2018	Beckman et al.
2018/0008356	A1	1/2018	Giordano et al.	2018/0168597	A1	6/2018	Fanelli et al.
2018/0008357	A1	1/2018	Giordano et al.	2018/0168598	A1	6/2018	Shelton, IV et al.
2018/0028184	A1	2/2018	Shelton, IV et al.	2018/0168599	A1	6/2018	Bakos et al.
2018/0028185	A1	2/2018	Shelton, IV et al.	2018/0168600	A1	6/2018	Shelton, IV et al.
2018/0042611	A1	2/2018	Swayze et al.	2018/0168601	A1	6/2018	Bakos et al.
2018/0049819	A1	2/2018	Harris et al.	2018/0168602	A1	6/2018	Bakos et al.
2018/0049824	A1	2/2018	Harris et al.	2018/0168603	A1	6/2018	Morgan et al.
2018/0049883	A1	2/2018	Moskowitz et al.	2018/0168604	A1	6/2018	Shelton, IV et al.
2018/0055513	A1	3/2018	Shelton, IV et al.	2018/0168605	A1	6/2018	Baber et al.
2018/0055524	A1	3/2018	Shelton, IV et al.	2018/0168606	A1	6/2018	Shelton, IV et al.
2018/0055525	A1	3/2018	Shelton, IV et al.	2018/0168607	A1	6/2018	Shelton, IV et al.
2018/0055526	A1	3/2018	Shelton, IV et al.	2018/0168608	A1	6/2018	Shelton, IV et al.
2018/0064437	A1	3/2018	Yates et al.	2018/0168609	A1	6/2018	Fanelli et al.
2018/0064440	A1	3/2018	Shelton, IV et al.	2018/0168610	A1	6/2018	Shelton, IV et al.
2018/0064441	A1	3/2018	Shelton, IV et al.	2018/0168611	A1	6/2018	Shelton, IV et al.
2018/0064442	A1	3/2018	Shelton, IV et al.	2018/0168613	A1	6/2018	Shelton, IV et al.
2018/0064443	A1	3/2018	Shelton, IV et al.	2018/0168614	A1	6/2018	Shelton, IV et al.
2018/0070939	A1	3/2018	Giordano et al.	2018/0168615	A1	6/2018	Shelton, IV et al.
2018/0070942	A1	3/2018	Shelton, IV et al.	2018/0168616	A1	6/2018	Shelton, IV et al.
2018/0078248	A1	3/2018	Swayze et al.	2018/0168617	A1	6/2018	Shelton, IV et al.
2018/0078268	A1	3/2018	Messerly et al.	2018/0168618	A1	6/2018	Scott et al.
2018/0085116	A1	3/2018	Yates et al.	2018/0168619	A1	6/2018	Scott et al.
2018/0085117	A1	3/2018	Shelton, IV et al.	2018/0168620	A1	6/2018	Huang et al.
2018/0103953	A1	4/2018	Shelton, IV et al.	2018/0168621	A1	6/2018	Shelton, IV et al.
2018/0103955	A1	4/2018	Shelton, IV et al.	2018/0168623	A1	6/2018	Simms et al.
2018/0110516	A1	4/2018	Baxter, III et al.	2018/0168624	A1	6/2018	Shelton, IV et al.
2018/0110518	A1	4/2018	Overmyer et al.	2018/0168625	A1	6/2018	Posada et al.
2018/0110519	A1	4/2018	Lytle, IV et al.	2018/0168626	A1	6/2018	Shelton, IV et al.
2018/0110520	A1	4/2018	Shelton, IV et al.	2018/0168627	A1	6/2018	Weaner et al.
2018/0110521	A1	4/2018	Shelton, IV et al.	2018/0168628	A1	6/2018	Hunter et al.
2018/0110522	A1	4/2018	Shelton, IV et al.	2018/0168629	A1	6/2018	Shelton, IV et al.
2018/0110523	A1	4/2018	Shelton, IV	2018/0168630	A1	6/2018	Shelton, IV et al.
2018/0110574	A1	4/2018	Shelton, IV et al.	2018/0168631	A1	6/2018	Harris et al.
2018/0110575	A1	4/2018	Shelton, IV et al.	2018/0168632	A1	6/2018	Harris et al.
2018/0114591	A1	4/2018	Pribanic et al.	2018/0168633	A1	6/2018	Shelton, IV et al.
2018/0116658	A1	5/2018	Aronhalt, IV et al.	2018/0168634	A1	6/2018	Harris et al.
2018/0116662	A1	5/2018	Shelton, IV et al.	2018/0168635	A1	6/2018	Shelton, IV et al.
2018/0116665	A1	5/2018	Hall et al.	2018/0168636	A1	6/2018	Shelton, IV et al.
2018/0125481	A1	5/2018	Yates et al.	2018/0168637	A1	6/2018	Harris et al.
2018/0125484	A1	5/2018	Kostrzewski	2018/0168638	A1	6/2018	Harris et al.
2018/0125487	A1	5/2018	Beardsley	2018/0168639	A1	6/2018	Shelton, IV et al.

US D914,878 S

2018/0168640	A1	6/2018	Shelton, IV et al.	2018/0368845	A1	12/2018	Bakos et al.
2018/0168641	A1	6/2018	Harris et al.	2018/0368846	A1	12/2018	Shelton, IV et al.
2018/0168642	A1	6/2018	Shelton, IV et al.	2018/0368847	A1	12/2018	Shelton, IV et al.
2018/0168643	A1	6/2018	Shelton, IV et al.	2019/0000446	A1	1/2019	Shelton, IV et al.
2018/0168644	A1	6/2018	Shelton, IV et al.	2019/0000448	A1	1/2019	Shelton, IV et al.
2018/0168645	A1	6/2018	Shelton, IV et al.	2019/0000450	A1	1/2019	Shelton, IV et al.
2018/0168646	A1	6/2018	Shelton, IV et al.	2019/0000454	A1	1/2019	Swayze et al.
2018/0168647	A1	6/2018	Shelton, IV et al.	2019/0000456	A1	1/2019	Shelton, IV et al.
2018/0168648	A1	6/2018	Shelton, IV et al.	2019/0000457	A1	1/2019	Shelton, IV et al.
2018/0168649	A1	6/2018	Shelton, IV et al.	2019/0000458	A1	1/2019	Shelton, IV et al.
2018/0168650	A1	6/2018	Shelton, IV et al.	2019/0000459	A1	1/2019	Shelton, IV et al.
2018/0168651	A1	6/2018	Shelton, IV et al.	2019/0000460	A1	1/2019	Shelton, IV et al.
2018/0168715	A1	6/2018	Strobl	2019/0000461	A1	1/2019	Shelton, IV et al.
2018/0199940	A1	7/2018	Zergiebel et al.	2019/0000462	A1	1/2019	Shelton, IV et al.
2018/0206843	A1	7/2018	Yates et al.	2019/0000463	A1	1/2019	Shelton, IV et al.
2018/0206844	A1*	7/2018	Harris A61B 17/105	2019/0000464	A1	1/2019	Shelton, IV et al.
2018/0206906	A1	7/2018	Moua et al.	2019/0000465	A1	1/2019	Shelton, IV et al.
2018/0214147	A1	8/2018	Merchant et al.	2019/0000466	A1	1/2019	Shelton, IV et al.
2018/0221046	A1	8/2018	Demmy et al.	2019/0000467	A1	1/2019	Shelton, IV et al.
2018/0221050	A1	8/2018	Kostrzewski et al.	2019/0000468	A1	1/2019	Adams et al.
2018/0228490	A1	8/2018	Richard et al.	2019/0000469	A1	1/2019	Shelton, IV et al.
2018/0242962	A1	8/2018	Walen et al.	2019/0000470	A1	1/2019	Yates et al.
2018/0250001	A1	9/2018	Aronhalt et al.	2019/0000471	A1	1/2019	Shelton, IV et al.
2018/0250020	A1	9/2018	Carusillo	2019/0000472	A1	1/2019	Shelton, IV et al.
2018/0250086	A1	9/2018	Grubbs	2019/0000473	A1	1/2019	Shelton, IV et al.
2018/0271520	A1	9/2018	Shelton, IV et al.	2019/0000474	A1	1/2019	Shelton, IV et al.
2018/0271604	A1	9/2018	Grout et al.	2019/0000475	A1	1/2019	Shelton, IV et al.
2018/0273597	A1	9/2018	Stimson	2019/0000476	A1	1/2019	Shelton, IV et al.
2018/0280020	A1	10/2018	Hess et al.	2019/0000477	A1	1/2019	Shelton, IV et al.
2018/0286274	A1	10/2018	Kamiguchi et al.	2019/0000478	A1	1/2019	Messerly et al.
2018/0289369	A1	10/2018	Shelton, IV et al.	2019/0000479	A1	1/2019	Harris et al.
2018/0296211	A1	10/2018	Timm et al.	2019/0000481	A1	1/2019	Harris et al.
2018/0296215	A1	10/2018	Baxter, III et al.	2019/0000525	A1	1/2019	Messerly et al.
2018/0296216	A1	10/2018	Shelton, IV et al.	2019/0000528	A1	1/2019	Yates et al.
2018/0296217	A1	10/2018	Moore et al.	2019/0000530	A1	1/2019	Yates et al.
2018/0303481	A1	10/2018	Shelton, IV et al.	2019/0000531	A1	1/2019	Messerly et al.
2018/0303482	A1	10/2018	Shelton, IV et al.	2019/0000534	A1	1/2019	Messerly et al.
2018/0310931	A1	11/2018	Hall et al.	2019/0000538	A1	1/2019	Widenhouse et al.
2018/0310935	A1	11/2018	Wixey	2019/0000555	A1	1/2019	Schings et al.
2018/0311002	A1	11/2018	Giordano et al.	2019/0000565	A1	1/2019	Shelton, IV et al.
2018/0317907	A1	11/2018	Kostrzewski	2019/0003292	A1	1/2019	Balan et al.
2018/0317916	A1	11/2018	Wixey	2019/0008509	A1	1/2019	Shelton, IV et al.
2018/0317917	A1	11/2018	Huang et al.	2019/0008511	A1	1/2019	Kerr et al.
2018/0317918	A1	11/2018	Shelton, IV	2019/0015096	A1	1/2019	Shelton, IV et al.
2018/0317919	A1	11/2018	Shelton, IV et al.	2019/0015102	A1	1/2019	Baber et al.
2018/0325528	A1	11/2018	Windolf et al.	2019/0015165	A1	1/2019	Giordano et al.
2018/0333155	A1	11/2018	Hall et al.	2019/0029675	A1	1/2019	Yates et al.
2018/0333169	A1	11/2018	Leimbach et al.	2019/0029676	A1	1/2019	Yates et al.
2018/0344319	A1	12/2018	Shelton, IV et al.	2019/0029677	A1	1/2019	Yates et al.
2018/0353170	A1	12/2018	Overmyer et al.	2019/0029678	A1	1/2019	Shelton, IV et al.
2018/0353176	A1	12/2018	Shelton, IV et al.	2019/0029681	A1	1/2019	Swayze et al.
2018/0353177	A1	12/2018	Shelton, IV et al.	2019/0029682	A1	1/2019	Huitema et al.
2018/0353178	A1	12/2018	Shelton, IV et al.	2019/0029701	A1	1/2019	Shelton, IV et al.
2018/0353179	A1	12/2018	Shelton, IV et al.	2019/0033955	A1	1/2019	Leimbach et al.
2018/0360443	A1	12/2018	Shelton, IV et al.	2019/0038279	A1	2/2019	Shelton, IV et al.
2018/0360445	A1	12/2018	Shelton, IV et al.	2019/0038281	A1	2/2019	Shelton, IV et al.
2018/0360446	A1	12/2018	Shelton, IV et al.	2019/0038282	A1	2/2019	Shelton, IV et al.
2018/0360447	A1	12/2018	Shelton, IV et al.	2019/0038283	A1	2/2019	Shelton, IV et al.
2018/0360448	A1	12/2018	Harris et al.	2019/0038292	A1	2/2019	Zhang
2018/0360449	A1	12/2018	Shelton, IV et al.	2019/0038371	A1	2/2019	Wixey et al.
2018/0360450	A1	12/2018	Shelton, IV et al.	2019/0046181	A1	2/2019	McCuen
2018/0360452	A1	12/2018	Shelton, IV et al.	2019/0046187	A1	2/2019	Yates et al.
2018/0360454	A1	12/2018	Shelton, IV et al.	2019/0059886	A1	2/2019	Shelton, IV et al.
2018/0360455	A1	12/2018	Shelton, IV et al.	2019/0076143	A1	3/2019	Smith
2018/0360456	A1	12/2018	Shelton, IV et al.	2019/0090870	A1	3/2019	Shelton, IV et al.
2018/0360471	A1	12/2018	Parfett et al.	2019/0090871	A1	3/2019	Shelton, IV et al.
2018/0360472	A1	12/2018	Harris et al.	2019/0091183	A1	3/2019	Tomat et al.
2018/0360473	A1	12/2018	Shelton, IV et al.	2019/0099177	A1	4/2019	Yates et al.
2018/0360549	A1	12/2018	Hares et al.	2019/0099178	A1	4/2019	Leimbach et al.
2018/0368822	A1	12/2018	Shelton, IV et al.	2019/0099179	A1	4/2019	Leimbach et al.
2018/0368833	A1	12/2018	Shelton, IV et al.	2019/0099180	A1	4/2019	Leimbach et al.
2018/0368837	A1	12/2018	Morgan et al.	2019/0099181	A1	4/2019	Shelton, IV et al.
2018/0368838	A1	12/2018	Shelton, IV et al.	2019/0099182	A1	4/2019	Bakos et al.
2018/0368839	A1	12/2018	Shelton, IV et al.	2019/0099183	A1	4/2019	Leimbach et al.
2018/0368840	A1	12/2018	Shelton, IV et al.	2019/0099184	A1	4/2019	Setser et al.
2018/0368841	A1	12/2018	Shelton, IV et al.	2019/0099224	A1	4/2019	Leimbach et al.
2018/0368842	A1	12/2018	Shelton, IV et al.	2019/0099229	A1	4/2019	Spivey et al.
2018/0368843	A1	12/2018	Shelton, IV et al.	2019/0102930	A1	4/2019	Leimbach et al.
2018/0368844	A1	12/2018	Bakos et al.	2019/0104919	A1	4/2019	Shelton, IV et al.

US D914,878 S

2019/0105035	A1	4/2019	Shelton, IV et al.	2019/0192141	A1	6/2019	Shelton, IV et al.
2019/0105036	A1	4/2019	Morgan et al.	2019/0192144	A1	6/2019	Parfett et al.
2019/0105037	A1	4/2019	Morgan et al.	2019/0192145	A1	6/2019	Shelton, IV et al.
2019/0105038	A1	4/2019	Schmid et al.	2019/0192146	A1	6/2019	Widenhouse et al.
2019/0105039	A1	4/2019	Morgan et al.	2019/0192147	A1	6/2019	Shelton, IV et al.
2019/0105043	A1	4/2019	Jaworek et al.	2019/0192148	A1	6/2019	Shelton, IV et al.
2019/0105044	A1	4/2019	Shelton, IV et al.	2019/0192149	A1	6/2019	Shelton, IV et al.
2019/0105049	A1	4/2019	Moore et al.	2019/0192150	A1	6/2019	Widenhouse et al.
2019/0110791	A1	4/2019	Shelton, IV et al.	2019/0192151	A1	6/2019	Shelton, IV et al.
2019/0110792	A1	4/2019	Shelton, IV et al.	2019/0192152	A1	6/2019	Morgan et al.
2019/0110793	A1	4/2019	Parihar et al.	2019/0192153	A1	6/2019	Shelton, IV et al.
2019/0117216	A1	4/2019	Overmyer et al.	2019/0192154	A1	6/2019	Shelton, IV et al.
2019/0117217	A1	4/2019	Overmyer et al.	2019/0192155	A1	6/2019	Shelton, IV et al.
2019/0117222	A1	4/2019	Shelton, IV et al.	2019/0192156	A1	6/2019	Simms et al.
2019/0117224	A1	4/2019	Setser et al.	2019/0192157	A1	6/2019	Scott et al.
2019/0117225	A1	4/2019	Moore et al.	2019/0192158	A1	6/2019	Scott et al.
2019/0125320	A1	5/2019	Shelton, IV et al.	2019/0192159	A1	6/2019	Simms et al.
2019/0125321	A1	5/2019	Shelton, IV et al.	2019/0192227	A1	6/2019	Shelton, IV et al.
2019/0125335	A1	5/2019	Shelton, IV et al.	2019/0192235	A1	6/2019	Harris et al.
2019/0125336	A1	5/2019	Deck et al.	2019/0192236	A1	6/2019	Shelton, IV et al.
2019/0125337	A1	5/2019	Shelton, IV et al.	2019/0200844	A1	7/2019	Shelton, IV et al.
2019/0125338	A1	5/2019	Shelton, IV et al.	2019/0200895	A1	7/2019	Shelton, IV et al.
2019/0125339	A1	5/2019	Shelton, IV et al.	2019/0200981	A1	7/2019	Harris et al.
2019/0125343	A1	5/2019	Wise et al.	2019/0200991	A1	7/2019	Moore et al.
2019/0125344	A1	5/2019	Dinardo et al.	2019/0200992	A1	7/2019	Moore et al.
2019/0125345	A1	5/2019	Baber et al.	2019/0200993	A1	7/2019	Moore et al.
2019/0125347	A1	5/2019	Stokes et al.	2019/0200994	A1	7/2019	Moore et al.
2019/0125348	A1	5/2019	Shelton, IV et al.	2019/0200998	A1	7/2019	Shelton, IV et al.
2019/0125352	A1	5/2019	Shelton, IV et al.	2019/0201025	A1	7/2019	Shelton, IV et al.
2019/0125353	A1	5/2019	Shelton, IV et al.	2019/0201028	A1	7/2019	Shelton, IV et al.
2019/0125354	A1	5/2019	Deck et al.	2019/0201045	A1	7/2019	Yates et al.
2019/0125355	A1	5/2019	Shelton, IV et al.	2019/0201046	A1	7/2019	Shelton, IV et al.
2019/0125356	A1	5/2019	Shelton, IV et al.	2019/0201047	A1	7/2019	Yates et al.
2019/0125357	A1	5/2019	Shelton, IV et al.	2019/0201136	A1	7/2019	Shelton, IV et al.
2019/0125358	A1	5/2019	Shelton, IV et al.	2019/0201137	A1	7/2019	Shelton, IV et al.
2019/0125359	A1	5/2019	Shelton, IV et al.	2019/0201594	A1	7/2019	Shelton, IV et al.
2019/0125360	A1	5/2019	Shelton, IV et al.	2019/0206562	A1	7/2019	Shelton, IV et al.
2019/0125361	A1	5/2019	Shelton, IV et al.	2019/0206563	A1	7/2019	Shelton, IV et al.
2019/0125365	A1	5/2019	Parfett et al.	2019/0206564	A1	7/2019	Shelton, IV et al.
2019/0125377	A1	5/2019	Shelton, IV	2019/0206569	A1	7/2019	Shelton, IV et al.
2019/0125378	A1	5/2019	Shelton, IV et al.	2019/0208641	A1	7/2019	Yates et al.
2019/0125379	A1	5/2019	Shelton, IV et al.	2019/0209164	A1	7/2019	Timm et al.
2019/0125380	A1	5/2019	Hunter et al.	2019/0209165	A1	7/2019	Timm et al.
2019/0125386	A1	5/2019	Shelton, IV et al.	2019/0209171	A1	7/2019	Shelton, IV et al.
2019/0125387	A1	5/2019	Parihar et al.	2019/0209172	A1	7/2019	Shelton, IV et al.
2019/0125388	A1	5/2019	Shelton, IV et al.	2019/0209247	A1	7/2019	Giordano et al.
2019/0125389	A1	5/2019	Shelton, IV et al.	2019/0209248	A1	7/2019	Giordano et al.
2019/0125430	A1	5/2019	Shelton, IV et al.	2019/0209249	A1	7/2019	Giordano et al.
2019/0125431	A1	5/2019	Shelton, IV et al.	2019/0209250	A1	7/2019	Giordano et al.
2019/0125432	A1	5/2019	Shelton, IV et al.	2019/0216558	A1	7/2019	Giordano et al.
2019/0125475	A1	5/2019	Wise et al.	2019/0223865	A1	7/2019	Shelton, IV et al.
2019/0125476	A1	5/2019	Shelton, IV et al.	2019/0223871	A1	7/2019	Moore et al.
2019/0133422	A1	5/2019	Nakamura	2019/0261984	A1	8/2019	Nelson et al.
2019/0133585	A1	5/2019	Smith et al.	2019/0261991	A1	8/2019	Beckman et al.
2019/0142421	A1	5/2019	Shelton, IV	2019/0267403	A1	8/2019	Li et al.
2019/0142449	A1	5/2019	Shelton, IV et al.	2019/0269400	A1	9/2019	Mandakolathur Vasudevan et al.
2019/0159778	A1	5/2019	Shelton, IV et al.	2019/0269402	A1	9/2019	Murray et al.
2019/0167266	A1*	6/2019	Patel A61B 17/07207	2019/0269403	A1	9/2019	Baxter, III et al.
2019/0183490	A1	6/2019	Shelton, IV et al.	2019/0269407	A1	9/2019	Swensgard et al.
2019/0183491	A1	6/2019	Shelton, IV et al.	2019/0269428	A1	9/2019	Allen et al.
2019/0183492	A1	6/2019	Shelton, IV et al.	2019/0274677	A1	9/2019	Shelton, IV
2019/0183493	A1	6/2019	Shelton, IV et al.	2019/0274678	A1	9/2019	Shelton, IV
2019/0183494	A1	6/2019	Shelton, IV et al.	2019/0274679	A1	9/2019	Shelton, IV
2019/0183495	A1	6/2019	Shelton, IV et al.	2019/0274680	A1	9/2019	Shelton, IV
2019/0183496	A1	6/2019	Shelton, IV et al.	2019/0274685	A1	9/2019	Olson et al.
2019/0183497	A1	6/2019	Shelton, IV et al.	2019/0290263	A1	9/2019	Morgan et al.
2019/0183498	A1	6/2019	Shelton, IV et al.	2019/0290264	A1	9/2019	Morgan et al.
2019/0183499	A1	6/2019	Shelton, IV et al.	2019/0290265	A1	9/2019	Shelton, IV et al.
2019/0183500	A1	6/2019	Shelton, IV et al.	2019/0290267	A1	9/2019	Baxter, III et al.
2019/0183501	A1	6/2019	Shelton, IV et al.	2019/0290274	A1	9/2019	Shelton, IV
2019/0183502	A1	6/2019	Shelton, IV et al.	2019/0290281	A1	9/2019	Aronhalt et al.
2019/0183503	A1	6/2019	Shelton, IV et al.	2019/0298348	A1	10/2019	Harris et al.
2019/0183504	A1	6/2019	Shelton, IV et al.	2019/0298354	A1	10/2019	Shelton, IV et al.
2019/0183505	A1	6/2019	Vendely et al.	2019/0298360	A1	10/2019	Shelton, IV et al.
2019/0183592	A1	6/2019	Shelton, IV et al.	2019/0298361	A1	10/2019	Shelton, IV et al.
2019/0183594	A1	6/2019	Shelton, IV et al.	2019/0298362	A1	10/2019	Shelton, IV et al.
2019/0183597	A1	6/2019	Shelton, IV et al.	2019/0307452	A1	10/2019	Shelton, IV et al.
2019/0192137	A1	6/2019	Shelton, IV et al.	2019/0307453	A1	10/2019	Shelton, IV et al.
2019/0192138	A1	6/2019	Shelton, IV et al.	2019/0307454	A1	10/2019	Shelton, IV et al.

2019/0307455	A1	10/2019	Shelton, IV et al.	2020/0138434	A1	5/2020	Miller et al.
2019/0307456	A1	10/2019	Shelton, IV et al.	2020/0138435	A1	5/2020	Shelton, IV et al.
2019/0307476	A1	10/2019	Shelton, IV et al.	2020/0138436	A1	5/2020	Yates et al.
2019/0307477	A1	10/2019	Shelton, IV et al.	2020/0138437	A1	5/2020	Vendely et al.
2019/0307478	A1	10/2019	Shelton, IV et al.	2020/0146678	A1	5/2020	Leimbach et al.
2019/0307479	A1	10/2019	Shelton, IV et al.	2020/0146741	A1	5/2020	Long et al.
2019/0314016	A1	10/2019	Huitema et al.	2020/0155151	A1	5/2020	Overmyer et al.
2019/0314017	A1	10/2019	Huitema et al.	2020/0155155	A1	5/2020	Shelton, IV et al.
2019/0314018	A1	10/2019	Huitema et al.	2020/0178958	A1	6/2020	Overmyer et al.
2019/0321039	A1	10/2019	Harris et al.	2020/0178960	A1	6/2020	Overmyer et al.
2019/0321040	A1	10/2019	Shelton, IV	2020/0187943	A1	6/2020	Shelton, IV et al.
2019/0321041	A1	10/2019	Shelton, IV	2020/0214706	A1	7/2020	Vendely et al.
2019/0328386	A1	10/2019	Harris et al.	2020/0214731	A1	7/2020	Shelton, IV et al.
2019/0328387	A1	10/2019	Overmyer et al.	2020/0222047	A1	7/2020	Shelton, IV et al.
2019/0328390	A1*	10/2019	Harris A61B 17/068	2020/0229812	A1	7/2020	Parihar et al.
2019/0336128	A1	11/2019	Harris et al.	2020/0229816	A1	7/2020	Bakos et al.
2019/0343514	A1	11/2019	Shelton, IV et al.	2020/0237371	A1	7/2020	Huitema et al.
2019/0343515	A1	11/2019	Morgan et al.	2020/0246001	A1	8/2020	Ming et al.
2019/0343518	A1	11/2019	Shelton, IV	2020/0253605	A1	8/2020	Swayze et al.
2019/0343525	A1	11/2019	Shelton, IV et al.	2020/0261106	A1	8/2020	Hess et al.
2019/0350582	A1	11/2019	Shelton, IV et al.	2020/0268377	A1	8/2020	Schmid et al.
2019/0357909	A1	11/2019	Huitema et al.	2020/0268394	A1	8/2020	Parfett et al.
2019/0365384	A1	12/2019	Baxter, III et al.	2020/0275926	A1	9/2020	Shelton, IV et al.
2019/0374224	A1	12/2019	Huitema et al.	2020/0275927	A1	9/2020	Shelton, IV et al.
2019/0388091	A1*	12/2019	Eschbach A61B 17/07207	2020/0275928	A1	9/2020	Shelton, IV et al.
2020/0000461	A1	1/2020	Yates et al.	2020/0275930	A1	9/2020	Harris et al.
2020/0000468	A1	1/2020	Shelton, IV et al.	2020/0281585	A1	9/2020	Timm et al.
2020/0000469	A1	1/2020	Shelton, IV et al.	2020/0281587	A1	9/2020	Schmid et al.
2020/0000471	A1	1/2020	Shelton, IV et al.	2020/0281590	A1	9/2020	Shelton, IV et al.
2020/0000531	A1	1/2020	Giordano et al.	2020/0297340	A1	9/2020	Hess et al.
2020/0008800	A1	1/2020	Shelton, IV et al.	2020/0297341	A1	9/2020	Yates et al.
2020/0008802	A1	1/2020	Aronhalt et al.	2020/0297346	A1	9/2020	Shelton, IV et al.
2020/0008809	A1	1/2020	Shelton, IV et al.	2020/0297438	A1	9/2020	Shelton, IV et al.
2020/0015815	A1	1/2020	Harris et al.	2020/0305862	A1	10/2020	Yates et al.
2020/0015819	A1	1/2020	Shelton, IV et al.	2020/0305863	A1	10/2020	Yates et al.
2020/0022702	A1	1/2020	Shelton, IV et al.	2020/0305864	A1	10/2020	Yates et al.
2020/0029964	A1	1/2020	Overmyer et al.	2020/0305865	A1	10/2020	Shelton, IV
2020/0030050	A1	1/2020	Shelton, IV et al.	2020/0305868	A1	10/2020	Shelton, IV
2020/0038016	A1	2/2020	Shelton, IV et al.	2020/0305869	A1	10/2020	Shelton, IV
2020/0038018	A1	2/2020	Shelton, IV et al.	2020/0305870	A1	10/2020	Shelton, IV
2020/0038020	A1	2/2020	Yates et al.	2020/0305871	A1	10/2020	Shelton, IV et al.
2020/0046348	A1	2/2020	Shelton, IV et al.	2020/0305874	A1	10/2020	Huitema et al.
2020/0046893	A1	2/2020	Shelton, IV et al.	2020/0352562	A1*	11/2020	Timm A61B 17/072
2020/0054320	A1	2/2020	Harris et al.				
2020/0054321	A1	2/2020	Harris et al.				
2020/0054322	A1	2/2020	Harris et al.				
2020/0054323	A1	2/2020	Harris et al.				
2020/0054324	A1	2/2020	Shelton, IV et al.				
2020/0054326	A1	2/2020	Harris et al.				
2020/0054327	A1	2/2020	Harris et al.				
2020/0054328	A1	2/2020	Harris et al.				
2020/0054329	A1	2/2020	Shelton, IV et al.				
2020/0054330	A1	2/2020	Harris et al.				
2020/0054331	A1	2/2020	Harris et al.				
2020/0054332	A1	2/2020	Shelton, IV et al.				
2020/0054333	A1	2/2020	Shelton, IV et al.				
2020/0054334	A1	2/2020	Shelton, IV et al.				
2020/0054355	A1	2/2020	Laurent et al.				
2020/0060680	A1	2/2020	Shelton, IV et al.				
2020/0060681	A1	2/2020	Shelton, IV et al.				
2020/0060713	A1	2/2020	Leimbach et al.				
2020/0077994	A1	3/2020	Shelton, IV et al.				
2020/0078015	A1	3/2020	Miller et al.				
2020/0078016	A1	3/2020	Swayze et al.				
2020/0085427	A1	3/2020	Giordano et al.				
2020/0085431	A1	3/2020	Swayze et al.				
2020/0085435	A1	3/2020	Shelton, IV et al.				
2020/0085436	A1	3/2020	Beckman et al.				
2020/0085518	A1	3/2020	Giordano et al.				
2020/0093484	A1	3/2020	Shelton, IV et al.				
2020/0093485	A1	3/2020	Shelton, IV et al.				
2020/0093487	A1	3/2020	Baber et al.				
2020/0093488	A1	3/2020	Baber et al.				
2020/0093506	A1	3/2020	Leimbach et al.				
2020/0093550	A1	3/2020	Spivey et al.				
2020/0100699	A1	4/2020	Shelton, IV et al.				
2020/0100783	A1	4/2020	Yates et al.				
2020/0100787	A1	4/2020	Shelton, IV et al.				
2020/0107829	A1	4/2020	Shelton, IV et al.				

FOREIGN PATENT DOCUMENTS

AU	2012200594	A1	2/2012
AU	2012203035	A1	6/2012
AU	2011218702	B2	6/2013
AU	2012200178	B2	7/2013
BR	112013027777	A2	1/2017
CA	1015829	A	8/1977
CA	1125615	A	6/1982
CA	2520413	A1	3/2007
CA	2725181	A1	11/2007
CA	2851239	A1	11/2007
CA	2664874	A1	11/2009
CA	2813230	A1	4/2012
CA	2940510	A1	8/2015
CA	2698728	C	8/2016
CN	1163558	A	10/1997
CN	2488482	Y	5/2002
CN	1634601	A	7/2005
CN	2716900	Y	8/2005
CN	2738962	Y	11/2005
CN	1777406	A	5/2006
CN	2796654	Y	7/2006
CN	2868212	Y	2/2007
CN	200942099	Y	9/2007
CN	200984209	Y	12/2007
CN	200991269	Y	12/2007
CN	201001747	Y	1/2008
CN	101143105	A	3/2008
CN	201029899	Y	3/2008
CN	101378791	A	3/2009
CN	101507635	A	8/2009
CN	101522120	A	9/2009
CN	101669833	A	3/2010
CN	101721236	A	6/2010

US D914,878 S

CN	101828940	A	9/2010	EP	0705571	A1	4/1996
CN	101873834	A	10/2010	EP	0528478	B1	5/1996
CN	201719298	U	1/2011	EP	0770355	A1	5/1997
CN	102038532	A	5/2011	EP	0625335	B1	11/1997
CN	201879759	U	6/2011	EP	0879742	A1	11/1998
CN	201949071	U	8/2011	EP	0650701	B1	3/1999
CN	102217961	A	10/2011	EP	0923907	A1	6/1999
CN	102217963	A	10/2011	EP	0484677	B2	7/2000
CN	102247183	A	11/2011	EP	1034747	A1	9/2000
CN	101779977	B	12/2011	EP	1034748	A1	9/2000
CN	101912284	B	7/2012	EP	0726632	B1	10/2000
CN	102125450	B	7/2012	EP	1053719	A1	11/2000
CN	202313537	U	7/2012	EP	1055399	A1	11/2000
CN	202397539	U	8/2012	EP	1055400	A1	11/2000
CN	202426586	U	9/2012	EP	1080694	A1	3/2001
CN	202489990	U	10/2012	EP	1090592	A1	4/2001
CN	102228387	B	11/2012	EP	1095627	A1	5/2001
CN	102835977	A	12/2012	EP	0806914	B1	9/2001
CN	202568350	U	12/2012	EP	1234587	A1	8/2002
CN	103037781	A	4/2013	EP	1284120	A1	2/2003
CN	203328751	U	12/2013	EP	0717967	B1	5/2003
CN	103505264	A	1/2014	EP	0869742	B1	5/2003
CN	103584893	A	2/2014	EP	1374788	A1	1/2004
CN	103690212	A	4/2014	EP	1407719	A2	4/2004
CN	203564285	U	4/2014	EP	0996378	B1	6/2004
CN	203564287	U	4/2014	EP	1157666	B1	9/2005
CN	203597997	U	5/2014	EP	0880338	B1	10/2005
CN	103829981	A	6/2014	EP	1158917	B1	11/2005
CN	103829983	A	6/2014	EP	1344498	B1	11/2005
CN	103908313	A	7/2014	EP	1330989	B1	12/2005
CN	203693685	U	7/2014	EP	1632191	A2	3/2006
CN	203736251	U	7/2014	EP	1082944	B1	5/2006
CN	103981635	A	8/2014	EP	1253866	B1	7/2006
CN	203815517	U	9/2014	EP	1723914	A1	11/2006
CN	102783741	B	10/2014	EP	1285633	B1	12/2006
CN	102973300	B	10/2014	EP	1011494	B1	1/2007
CN	204092074	U	1/2015	EP	1767163	A1	3/2007
CN	104337556	A	2/2015	EP	1837041	A1	9/2007
CN	204158440	U	2/2015	EP	0922435	B1	10/2007
CN	204158441	U	2/2015	EP	1599146	B1	10/2007
CN	102469995	B	3/2015	EP	1330201	B1	6/2008
CN	104586463	A	5/2015	EP	2039302	A2	3/2009
CN	204636451	U	9/2015	EP	1719461	B1	6/2009
CN	103860225	B	3/2016	EP	2116196	A2	11/2009
CN	103750872	B	5/2016	EP	1769754	B1	6/2010
CN	103648410	B	10/2016	EP	1627605	B1	12/2010
CN	106344091	A	1/2017	EP	2316345	A1	5/2011
CN	104349800	B	11/2017	EP	1962711	B1	2/2012
CN	107635483	A	1/2018	EP	2486862	A2	8/2012
DE	273689	C	5/1914	EP	2486868	A2	8/2012
DE	1775926	A	1/1972	EP	2517638	A1	10/2012
DE	3036217	A1	4/1982	EP	2606812	A1	6/2013
DE	3210466	A1	9/1983	EP	2649948	A1	10/2013
DE	3709067	A1	9/1988	EP	2649949	A1	10/2013
DE	19534043	A1	3/1997	EP	2668910	A2	12/2013
DE	19851291	A1	1/2000	EP	2687164	A2	1/2014
DE	19924311	A1	11/2000	EP	2713902	A1	4/2014
DE	20016423	U1	2/2001	EP	2743042	A2	6/2014
DE	20112837	U1	10/2001	EP	2764827	A2	8/2014
DE	20121753	U1	4/2003	EP	2777524	A2	9/2014
DE	202004012389	U1	9/2004	EP	2842500	A1	3/2015
DE	10314072	A1	10/2004	EP	2853220	A1	4/2015
DE	102004014011	A1	10/2005	EP	2298220	B1	6/2016
DE	102004063606	A1	7/2006	EP	2510891	B1	6/2016
DE	202007003114	U1	6/2007	EP	3031404	A1	6/2016
DE	102010013150	A1	9/2011	EP	3047806	A1	7/2016
DE	102012213322	A1	1/2014	EP	3078334	A1	10/2016
EM	002220467-0008		4/2013	EP	2364651	B1	11/2016
EP	0000756	A1	2/1979	EP	2747235	B1	11/2016
EP	0122046	A1	10/1984	EP	3095399	A2	11/2016
EP	0129442	B1	11/1987	EP	3120781	A2	1/2017
EP	0255631	A1	2/1988	EP	3135225	A2	3/2017
EP	0169044	B1	6/1991	EP	2789299	B1	5/2017
EP	0541950	A1	5/1993	EP	3225190	A2	10/2017
EP	0548998	A1	6/1993	EP	3363378	A1	8/2018
EP	0594148	A1	4/1994	EP	3275378	B1	7/2019
EP	0646357	A1	4/1995	FR	459743	A	11/1913
EP	0505036	B1	5/1995	FR	999646	A	2/1952
EP	0669104	A1	8/1995	FR	1112936	A	3/1956

US D914,878 S

FR	2598905	A1	11/1987	JP	2005137423	A	6/2005
FR	2689749	B1	7/1994	JP	2005187954	A	7/2005
FR	2765794	A1	1/1999	JP	2005211455	A	8/2005
FR	2815842	A1	5/2002	JP	2005328882	A	12/2005
GB	939929	A	10/1963	JP	2005335432	A	12/2005
GB	1210522	A	10/1970	JP	2005342267	A	12/2005
GB	1217159	A	12/1970	JP	3791856	B2	6/2006
GB	1339394	A	12/1973	JP	2006187649	A	7/2006
GB	2024012	A	1/1980	JP	2006218228	A	8/2006
GB	2109241	A	6/1983	JP	2006281405	A	10/2006
GB	2090534	B	6/1984	JP	2006291180	A	10/2006
GB	2272159	A	5/1994	JP	2006346445	A	12/2006
GB	2336214	A	10/1999	JP	2007289715	A	11/2007
GB	2509523	A	7/2014	JP	D1322057		2/2008
GR	930100110	A	11/1993	JP	2008220032	A	9/2008
JP	S4711908	Y1	5/1972	JP	2009507526	A	2/2009
JP	S5367286	A	6/1978	JP	2009189838	A	8/2009
JP	S56112235	A	9/1981	JP	2009189846	A	8/2009
JP	S60113007	A	6/1985	JP	2009207260	A	9/2009
JP	S62170011	U	10/1987	JP	2009226028	A	10/2009
JP	S63270040	A	11/1988	JP	2009538684	A	11/2009
JP	S63318824	A	12/1988	JP	2009539420	A	11/2009
JP	H0129503	B2	6/1989	JP	D1383743		2/2010
JP	H0378514	U	8/1991	JP	2010069307	A	4/2010
JP	H0385009	U	8/1991	JP	2010069310	A	4/2010
JP	H04215747	A	8/1992	JP	2010098844	A	4/2010
JP	H04131860	U	12/1992	JP	2010214128	A	9/2010
JP	H0584252	A	4/1993	JP	2011072574	A	4/2011
JP	H05123325	A	5/1993	JP	4722849	B2	7/2011
JP	H05226945	A	9/1993	JP	4728996	B2	7/2011
JP	H0630945	A	2/1994	JP	2011524199	A	9/2011
JP	H06237937	A	8/1994	JP	D1432094		12/2011
JP	H06327684	A	11/1994	JP	2012115542	A	6/2012
JP	H079622	U	2/1995	JP	2012143283	A	8/2012
JP	H07124166	A	5/1995	JP	2012145767	A	8/2012
JP	H07163573	A	6/1995	JP	5154710	B1	2/2013
JP	H07255735	A	10/1995	JP	2013099551	A	5/2013
JP	H07285089	A	10/1995	JP	2013126430	A	6/2013
JP	H08164141	A	6/1996	JP	D1481426		9/2013
JP	H08182684	A	7/1996	JP	2013541983	A	11/2013
JP	H08507708	A	8/1996	JP	D1492363		2/2014
JP	H08229050	A	9/1996	JP	2014121599	A	7/2014
JP	H08289895	A	11/1996	JP	1517663	S	2/2015
JP	H09-323068	A	12/1997	JP	2015512725	A	4/2015
JP	H10118090	A	5/1998	JP	2015513956	A	5/2015
JP	H10-200699	A	7/1998	JP	2015513958	A	5/2015
JP	H10296660	A	11/1998	JP	2015514471	A	5/2015
JP	2000014632	A	1/2000	JP	2015521525	A	7/2015
JP	2000033071	A	2/2000	JP	2016512057	A	4/2016
JP	2000112002	A	4/2000	JP	1601498	S	4/2018
JP	2000166932	A	6/2000	KR	20100110134	A	10/2010
JP	2000171730	A	6/2000	KR	20110003229	A	1/2011
JP	2000271141	A	10/2000	KR	300631507		3/2012
JP	2000287987	A	10/2000	KR	300747646		6/2014
JP	2000325303	A	11/2000	RU	1814161	C	5/1993
JP	2001087272	A	4/2001	RU	2008830	C1	3/1994
JP	2001514541	A	9/2001	RU	2052979	C1	1/1996
JP	2001276091	A	10/2001	RU	2066128	C1	9/1996
JP	2002051974	A	2/2002	RU	2069981	C1	12/1996
JP	2002054903	A	2/2002	RU	2098025	C1	12/1997
JP	2002085415	A	3/2002	RU	2104671	C1	2/1998
JP	2002143078	A	5/2002	RU	2110965	C1	5/1998
JP	2002153481	A	5/2002	RU	2141279	C1	11/1999
JP	2002528161	A	9/2002	RU	2144791	C1	1/2000
JP	2002314298	A	10/2002	RU	2161450	C1	1/2001
JP	2003135473	A	5/2003	RU	2181566	C2	4/2002
JP	2003521301	A	7/2003	RU	2187249	C2	8/2002
JP	3442423	B2	9/2003	RU	32984	U1	10/2003
JP	2003300416	A	10/2003	RU	2225170	C2	3/2004
JP	2004147701	A	5/2004	RU	42750	U1	12/2004
JP	2004162035	A	6/2004	RU	61114	U1	2/2007
JP	2004229976	A	8/2004	RU	61122	U1	2/2007
JP	2005013573	A	1/2005	RU	2430692	C2	10/2011
JP	2005080702	A	3/2005	SU	189517	A	1/1967
JP	2005131163	A	5/2005	SU	297156	A	5/1971
JP	2005131164	A	5/2005	SU	328636	A	9/1972
JP	2005131173	A	5/2005	SU	511939	A1	4/1976
JP	2005131211	A	5/2005	SU	674747	A1	7/1979
JP	2005131212	A	5/2005	SU	728848	A1	4/1980

SU 1009439 A 4/1983
 SU 1271497 A1 11/1986
 SU 1333319 A2 8/1987
 SU 1377052 A1 2/1988
 SU 1377053 A1 2/1988
 SU 1443874 A1 12/1988
 SU 1509051 A1 9/1989
 SU 1561964 A1 5/1990
 SU 1708312 A1 1/1992
 SU 1722476 A1 3/1992
 SU 1752361 A1 8/1992
 SU 1814161 A1 5/1993
 WO WO-9315648 A1 8/1993
 WO WO-9420030 A1 9/1994
 WO WO-9517855 A1 7/1995
 WO WO-9520360 A1 8/1995
 WO WO-9623448 A1 8/1996
 WO WO-9635464 A1 11/1996
 WO WO-9639086 A1 12/1996
 WO WO-9639088 A1 12/1996
 WO WO-9724073 A1 7/1997
 WO WO-9734533 A1 9/1997
 WO WO-9827870 A1 7/1998
 WO WO-9903407 A1 1/1999
 WO WO-9903409 A1 1/1999
 WO WO-9948430 A1 9/1999
 WO WO-0024322 A1 5/2000
 WO WO-0024330 A1 5/2000
 WO WO-0053112 A2 9/2000
 WO WO-0024448 A2 10/2000
 WO WO-0057796 A1 10/2000
 WO WO-0105702 A1 1/2001
 WO WO-0154594 A1 8/2001
 WO WO-0158371 A1 8/2001
 WO WO-0162164 A2 8/2001
 WO WO-0162169 A2 8/2001
 WO WO-0191646 A1 12/2001
 WO WO-0219932 A1 3/2002
 WO WO-0226143 A1 4/2002
 WO WO-0236028 A1 5/2002
 WO WO-02065933 A2 8/2002
 WO WO-03055402 A1 7/2003
 WO WO-03094747 A1 11/2003
 WO WO-03079909 A3 3/2004
 WO WO-2004019803 A1 3/2004
 WO WO-2004032783 A1 4/2004
 WO WO-2004047626 A1 6/2004
 WO WO-2004047653 A2 6/2004
 WO WO-2004056277 A1 7/2004
 WO WO-2004078050 A2 9/2004
 WO WO-2004078051 A2 9/2004
 WO WO-2004096015 A2 11/2004
 WO WO-2006044581 A2 4/2006
 WO WO-2006051252 A1 5/2006
 WO WO-2006059067 A1 6/2006
 WO WO-2006073581 A2 7/2006
 WO WO-2006085389 A1 8/2006
 WO WO-2007015971 A2 2/2007
 WO WO-2007074430 A1 7/2007
 WO WO-2007129121 A1 11/2007
 WO WO-2007137304 A2 11/2007
 WO WO-2007142625 A2 12/2007
 WO WO-2008021969 A2 2/2008
 WO WO-2008061566 A1 5/2008
 WO WO-2008089404 A2 7/2008
 WO WO-2009005969 A2 1/2009
 WO WO-2009067649 A2 5/2009
 WO WO-2009091497 A2 7/2009
 WO WO-2010126129 A1 11/2010
 WO WO-2010134913 A1 11/2010
 WO WO-2011008672 A2 1/2011
 WO WO-2011044343 A2 4/2011
 WO WO-2012006306 A2 1/2012
 WO WO-2012013577 A1 2/2012
 WO WO-2012044606 A2 4/2012
 WO WO-2012061725 A1 5/2012
 WO WO-2012072133 A1 6/2012
 WO WO-2012166503 A1 12/2012
 WO WO-2013087092 A1 6/2013

WO WO-2013151888 A1 10/2013
 WO WO-2014004209 A2 1/2014
 WO WO-2014113438 A1 7/2014
 WO WO-2015032797 A1 3/2015
 WO WO-2015138760 A1 9/2015
 WO WO-2015187107 A1 12/2015
 WO WO-2016100682 A1 6/2016
 WO WO-2016107448 A1 7/2016

OTHER PUBLICATIONS

“Biomedical Coatings,” Fort Wayne Metals, Research Products Corporation, obtained online at www.fwmetals.com on Jun. 21, 2010 (1 page).

“Foot and Ankle: Core Knowledge in Orthopaedics”; by DiGiovanni MD, Elsevier; (p. 27, left column, heading “Materials for Soft Orthoses”, 7th bullet point); (Year: 2007).

“Indian Standard: Automotive Vehicles - Brakes and Braking Systems (IS 11852-1:2001)”, Mar. 1, 2001.

“Pushing Pixels (GIF)”, published on dribbble.com, 2013.

“Sodium stearate C18H35NaO2”, Chemspider Search and Share Chemistry, Royal Society of Chemistry, pp. 1-3, 2015, <http://www.chemspider.com/Chemical-Structure.12639.html>, accessed May 23, 2016.

“Tutorial overview of inductively coupled RFID Systems,” UPM, May 2003, pp. 1-7, UPM Rafsec, <<http://cdn.mobiusconsulting.com/papers/rfidsystems.pdf>>.

A.V. Kasture and S.G. Wadodkar, Pharmaceutical Chemistry-II: Second Year Diploma in Pharmacy, Nirali Prakashan, p. 339, 2007.

Adeeb, et al., “An Inductive Link-Based Wireless Power Transfer System for Biomedical Applications,” Research Article, Nov. 14, 2011. pp. 1-12, vol. 2012, Article ID 879294, Hindawi Publishing Corporation.

Anonymous, Analog Devices Wiki, Chapter 11: The Current Mirror, Aug. 20, 2017, 22 pages. <https://wiki.analog.com/university/courses/electronics/text/chapter-11?rev=1503222341>.

Anonymous: “Sense & Control Application Note Current Sensing Using Linear Hall Sensors,” Feb. 3, 2009, pp. 1-18. Retrieved from the Internet: URL: http://www.infineon.com/dgdl/Current_Sensing_Rev.1.1.pdf?fileId=db3a304332d040720132d939503e5f17 [retrieved on Oct. 18, 2016].

Arrow Sign Icon Next Button, by Blan-k, shutterstock.com [online], published on or before Aug. 6, 2014, [retrieved on Jun. 4, 2019], retrieved from the Internet [URL:<https://www.shutterstock.com/de/image-vector/arrow-sign-icon-next-button-navigation-207700303?irgwc=1&utm...> see PDF in file for full URL] (Year: 2014).

ASTM procedure D2240-00, “Standard Test Method for Rubber Property-Durometer Hardness,” (Published Aug. 2000).

ASTM procedure D2240-05, “Standard Test Method for Rubber Property-Durometer Hardness,” (Published Apr. 2010).

B.R. Coolman, DVM, Ms et al., “Comparison of Skin Staples With Sutures for Anastomosis of the Small Intestine in Dogs,” Abstract; <http://www.blackwell-synergy.com/doi/abs/10.1053/jvet.2000.7539?cookieSet=1&journalCode=vsu> which redirects to <http://www3.interscience.wiley.com/journal/119040681/abstract?CRETRY=1&SRETRY=0>; [online] accessed: Sep. 22, 2008 (2 pages).

Brar et al., “Investigation of the mechanical and degradation properties of Mg-Sr and Mg-Zn-Sr alloys for use as potential biodegradable implant materials,” J. Mech. Behavior of Biomed. Mater. 7 (2012) pp. 87-95.

Breedveld et al., “A New, Easily Miniaturized Sterrable Endoscope,” IEEE Engineering in Medicine and Biology Magazine (Nov./Dec. 2005).

Byrne et al., “Molecular Imprinting Within Hydrogels,” Advanced Drug Delivery Reviews, 54 (2002) pp. 149-161.

C.C. Thompson et al., “Peroral Endoscopic Reduction of Dilated Gastrojejunal Anastomosis After Roux-en-Y Gastric Bypass: A Possible New Option for Patients with Weight Regain,” Surg Endosc (2006) vol. 20., pp. 1744-1748.

Chen et al., “Elastomeric Biomaterials for Tissue Engineering,” Progress in Polymer Science 38 (2013), pp. 584-671.

Covidien Brochure, “Endo GIA™ Curved Tip Reload with Tri-Staple™ Technology,” (2012), 2 pages.

- Covidien Brochure, "Endo GIA™ Reloads with Tri-Staple™ Technology and Endo GIA™ Ultra Universal Staplers," (2010), 2 pages.
- Covidien Brochure, "Endo GIA™ Reloads with Tri-Staple™ Technology," (2010), 1 page.
- Covidien Brochure, "Endo GIA™ Reloads with Tri-Staple™ Technology," (2010), 2 pages.
- Covidien Brochure, "Endo GIA™ Black Reload with Tri-Staple™ Technology," (2012), 2 pages.
- Covidien Brochure, "Endo GIA™ Ultra Universal Stapler," (2010), 2 pages.
- Cuper et al., "The Use of Near-Infrared Light for Safe and Effective Visualization of Subsurface Blood Vessels to Facilitate Blood Withdrawal in Children," *Medical Engineering & Physics*, vol. 35, No. 4, pp. 433-440 (2013).
- D. Tuite, Ed., "Get the Lowdown on Ultracapacitors," Nov. 15, 2007; [online] URL: <http://electronicdesign.com/Articles/Print.cfm?ArticleID-17465>, accessed Jan. 15, 2008 (5 pages).
- Data Sheet of LM4F230H5QR, 2007.
- Datasheet for Panasonic TK Relays Ultra Low Profile 2 A Polarized Relay, Copyright Matsushita Electric Works, Ltd. (Known of at least as early as Aug. 17, 2010), 5 pages.
- Disclosed Anonymously, "Motor-Driven Surgical Stapler Improvements," Research Disclosure Database No. 526041, Published: Feb. 2008.
- Ebara, "Carbohydrate-Derived Hydrogels and Microgels," *Engineered Carbohydrate-Based Materials for Biomedical Applications: Polymers, Surfaces, Dendrimers, Nanoparticles, and Hydrogels*, Edited by Ravin Narain, 2011, pp. 337-345.
- Elite Icons, by smart/icons, iconfinder.com [online], published on Aug. 18, 2016, [retrieved on Jun. 4, 2019], retrieved from the Internet [URL: <https://www.iconfinder.com/iconsets/elite>] (Year: 2016).
- Fast, Versatile Blackfin Processors Handle Advanced RFID Reader Applications; *Analog Dialogue*: vol. 40—Sep. 2006; <http://www.analog.com/library/analogDialogue/archives/40-09/rfid.pdf>; Wayback Machine to Feb. 15, 2012.
- Fischer, Martin H, "Colloid-Chemical Studies on Soaps", *The Chemical Engineer*, pp. 184-193, Aug. 1919.
- Forum discussion regarding "Speed is Faster", published on Oct. 1, 2014 and retrieved on Nov. 8, 2019 from URL <https://english.stackexchange.com/questions/199018/how-is-that-correct-speed-is-faster-or-prices-are-cheaper> (Year: 2014).
- Gao et al., "Mechanical Signature Enhancement of Response Vibrations in the Time Lag Domain," *Fifth International Congress on Sound and Vibration*, Dec. 15-18, 1997, pp. 1-8.
- Hoffman, "Hydrogels for Biomedical Applications," *Advanced Drug Delivery Reviews*, 43 (2002) pp. 3-12.
- Hoffman, "Hydrogels for Biomedical Applications," *Advanced Drug Delivery Reviews*, 54 (2002) pp. 3-12.
- Honda HS1332AT and ATD Model Info, powerequipment.honda.com [online], published on or before Mar. 22, 2016, [retrieved on May 31, 2019], retrieved from the Internet [URL: <https://powerequipment.honda.com/snowblowers/models/hss1332at-hss1332atd>] {Year: 2016}.
- <http://ninpgan.net/publications/51-100/89.pdf>; 2004, Ning Pan, On Uniqueness of Fibrous Materials, *Design & Nature II*. Eds: Colins, M. and Brebbia, C. Wit Press, Boston, 493-504.
- Jeong et al., "Thermosensitive Sol-Gel Reversible Hydrogels," *Advanced Drug Delivery Reviews*, 54 (2002) pp. 37-51.
- Kawamura, Atsuo, et al. "Wireless Transmission of Power and Information Through One High-Frequency Resonant AC Link Inverter for Robot Manipulator Applications," *Journal*, May/June. 1996, pp. 503-508, vol. 32, No. 3, *IEEE Transactions on Industry Applications*.
- Lee, Youbok, "Antenna Circuit Design for RFID Applications," 2003, pp. 1-50, DS00710C, Microchip Technology Inc., Available: <http://ww1.microchip.com/downloads/en/AppNotes/00710c.pdf>.
- Lyon et al. "The Relationship Between Current Load and Temperature for Quasi-Steady State and Transient Conditions," *SPIE—International Society for Optical Engineering. Proceedings*, vol. 4020, (pp. 62-70), Mar. 30, 2000.
- Matsuda, "Thermodynamics of Formation of Porous Polymeric Membrane from Solutions," *Polymer Journal*, vol. 23, No. 5, pp. 435-444 (1991).
- Miyata et al., "Biomolecule-Sensitive Hydrogels," *Advanced Drug Delivery Reviews*, 54 (2002) pp. 79-98.
- Mouser Electronics, "LM317 3-Terminal Adjustable Regulator with Overcurrent/Overtemperature Self Protection", Sep. 30, 2016 (Sep. 30, 2016), XP0555246104, Retrieved from the Internet: URL: <http://www.mouser.com/ds/2/405/lm317m-440423.pdf>, pp. 1-9.
- Mouser Electronics, "LM317M 3-Terminal Adjustable Regulator with Overcurrent/Overtemperature Self Protection", Mar. 31, 2014 (Mar. 31, 2014), XP0555246104, Retrieved from the Internet: URL: <http://www.mouser.com/ds/2/405/lm317m-440423.pdf>, pp. 1-8.
- NF Monographs: Sodium Stearate, U.S. Pharmacopeia, http://www.pharmacopeia.cn/v29240/usp29nf24s0_m77360.html, accessed May 23, 2016.
- Pellicer et al. "On the biodegradability, mechanical behavior, and cytocompatibility of amorphous Mg72Zn23Ca5 and crystalline Mg70Zn23Ca5Pd2 alloys as temporary implant materials," *J Biomed Mater Res Part A*, 2013:101A:502-517.
- Peppas, "Physiologically Responsive Hydrogels," *Journal of Bioactive and Compatible Polymers*, vol. 6 (Jul. 1991) pp. 241-246.
- Peppas, Editor "Hydrogels in Medicine and Pharmacy," vol. I, *Fundamentals*, CRC Press, 1986.
- Pitt et al., "Attachment of Hyaluronan to Metallic Surfaces," *J. Biomed. Mater. Res.* 68A: pp. 95-106, 2004.
- Qiu et al., "Environment-Sensitive Hydrogels for Drug Delivery," *Advanced Drug Delivery Reviews*, 53 (2001) pp. 321-339.
- Qiu Li Loh et al.: "Three-Dimensional Scaffolds for Tissue Engineering Applications: Role of Porosity and Pore Size", *Tissue Engineering Part B-Reviews*, vol. 19, No. 6, Dec. 1, 2013, pp. 485-502.
- Schellhammer et al., "Poly-Lactic-Acid for Coating of Endovascular Stents: Preliminary Results in Canine Experimental Av-Fistulae," *Mat.-wiss. u. Werkstofftech.*, 32, pp. 193-199 (2001).
- Schroeter, John, "Demystifying UHF Gen 2 RFID, HF RFID," *Online Article*, Jun. 2, 2008, pp. 1-3, <<https://www.edn.com/design/industrial-control/4019123/Demystifying-UHF-Gen-2-RFID-HF-RFID>>.
- Serial Communication Protocol; Michael Lemmon Feb. 1, 2009; <http://www3.nd.edu/~lemmon/courses/ee224/web-manual/web-manual/lab12/node2.html>; Wayback Machine to Apr. 29, 2012.
- Slow Safety Sign, shutterstock.com [online], published on or before May 9, 2017, [retrieved on May 31, 2019], retrieved from the <https://www.shutterstock.com/image-vector/slow-safety-sign-two-dimensional-turtle-symbolizing-...> see PDF in file for full URL] (Year: 2017).
- Solorio et al., "Gelatin Microspheres Crosslinked with Genipin for Local Delivery of Growth Factors," *J. Tissue Eng. Regen. Med.* (2010), 4(7): pp. 514-523.
- Texas Instruments: "Current Recirculation and Decay Modes," *Application Report SLVA321—Mar. 2009*; Retrieved from the Internet: URL:<http://www.ti.com/lit/an/slva321/slva321> [retrieved on Apr. 25, 2017], 7 pages.
- The Sodem Aseptic Battery Transfer Kit, Sodem Systems, 2000, 3 pages.
- Trendafilova et al., "Vibration-based Methods for Structural and Machinery Fault Diagnosis Based on Nonlinear Dynamics Tools," In: *Fault Diagnosis in Robotic and Industrial Systems*, IConcept Press LTD, 2012, pp. 1-29.
- V.K. Ahluwalia and Madhuri Goyal, *A Textbook of Organic Chemistry*, Section 19.11.3, p. 356, 2000.
- Van Meer et al., "A Disposable Plastic Compact Wrist for Smart Minimally Invasive Surgical Tools," *LAAS/CNRS* (Aug. 2005).
- Warning Sign Beveled Buttons, by Peter, [flarestock.com](http://www.flarestock.com) [online], published on or before Jan. 1, 2017, [retrieved on Jun. 4, 2019], retrieved from the Internet [URL: <https://www.flarestock.com/stock-images/warning-sign-beveled-buttons/70257>] (Year: 2017).
- Yan et al, Comparison of the effects of Mg-6Zn and Ti-3Al-2.5V alloys on TGF-β/TNF-60 /VEGF/b-FGF in the healing of the intestinal track in vivo, *Biomed. Mater.* 9 (2014), 11 pages.
- Yan et al., "Comparison of the effects of Mg-6Zn and titanium on intestinal tract in vivo," *J Mater Sci: Mater Med* (2013), 11 pages.
- Young, "Microcellular foams via phase separation," *Journal of Vacuum Science & Technology A* 4(3), (May/June. 1986).

Youtube.com; video by Fibran (retrieved from URL <https://www.youtube.com/watch?v=vN2Qjt51gFQ>); (Year: 2018).

“Understanding the Requirements of ISO/IEC 14443 for Type B Proximity Contactless Identification Cards,” retrieved from <https://www.digchip.com/application-notes/22/15746.php> on Mar. 2, 2020, pp. 1-28 (Nov. 2005).

Jauchem, J.R., “Effects of low-level radio-frequency (3 kHz to 300 GHz) energy on human cardiovascular, reproductive, immune, and other systems: A review of the recent literated,” *Int. J. Hyg. Environ. Health* 211 (2008) 1-29.

Sandvik, “Welding Handbook,” <https://www.meting.rs/wp-content/uploads/2018/05/welding-handbook.pdf>, retrieved on Jun. 22, 2020, pp. 5-6.

Ludois, Daniel C., “Capacitive Power Transfer for Rotor Field Current in Synchronous Machines,” *IEEE Transactions on Power Electronics*, Institute of Electrical and Electronics Engineers, USA, vol. 27, No. 11, Nov. 1, 2012, pp. 4638-4645.

Rotary Systems: Sealed Slip Ring Categories, Rotary Systems, May 22, 2017, retrieved from the internet: <http://web.archive.org/web/20170522174710/http://rotarysystems.com:80/slip-rings/sealed/>, retrieved on Aug. 12, 2020, pp. 1-2.

* cited by examiner

Primary Examiner — Wan Laymon

(57)

CLAIM

The ornamental design for a surgical instrument anvil, as shown and described.

DESCRIPTION

FIG. 1 is a perspective view of a surgical instrument anvil.

FIG. 2 is a left elevation view of the surgical instrument anvil of FIG. 1.

FIG. 3 is a right elevation view of the surgical instrument anvil of FIG. 1.

FIG. 4 is a top plan view of the surgical instrument anvil of FIG. 1.

FIG. 5 is a bottom plan view of the surgical instrument anvil of FIG. 1.

FIG. 6 is an enlarged front elevation view of the surgical instrument anvil of FIG. 1.

FIG. 7 is an enlarged rear elevation view of the surgical instrument anvil of FIG. 1.

FIG. 8 is a perspective view of a surgical instrument anvil.

FIG. 9 is a left elevation view of the surgical instrument anvil of FIG. 8.

FIG. 10 is a right elevation view of the surgical instrument anvil of FIG. 8.

FIG. 11 is a top plan view of the surgical instrument anvil of FIG. 8.

FIG. 12 is a bottom plan view of the surgical instrument anvil of FIG. 8.

FIG. 13 is an enlarged front elevation view of the surgical instrument anvil of FIG. 8.

FIG. 14 is an enlarged rear elevation view of the surgical instrument anvil of FIG. 8.

FIG. 15 is a perspective view of a surgical instrument anvil.

FIG. 16 is a left elevation view of the surgical instrument anvil of FIG. 15.

FIG. 17 is a right elevation view of the surgical instrument anvil of FIG. 15.

FIG. 18 is a top plan view of the surgical instrument anvil of FIG. 15.

FIG. 19 is a bottom plan view of the surgical instrument anvil of FIG. 15.

FIG. 20 is an enlarged front elevation view of the surgical instrument anvil of FIG. 15; and,

FIG. 21 is an enlarged rear elevation view of the surgical instrument anvil of FIG. 15.

1 Claim, 12 Drawing Sheets

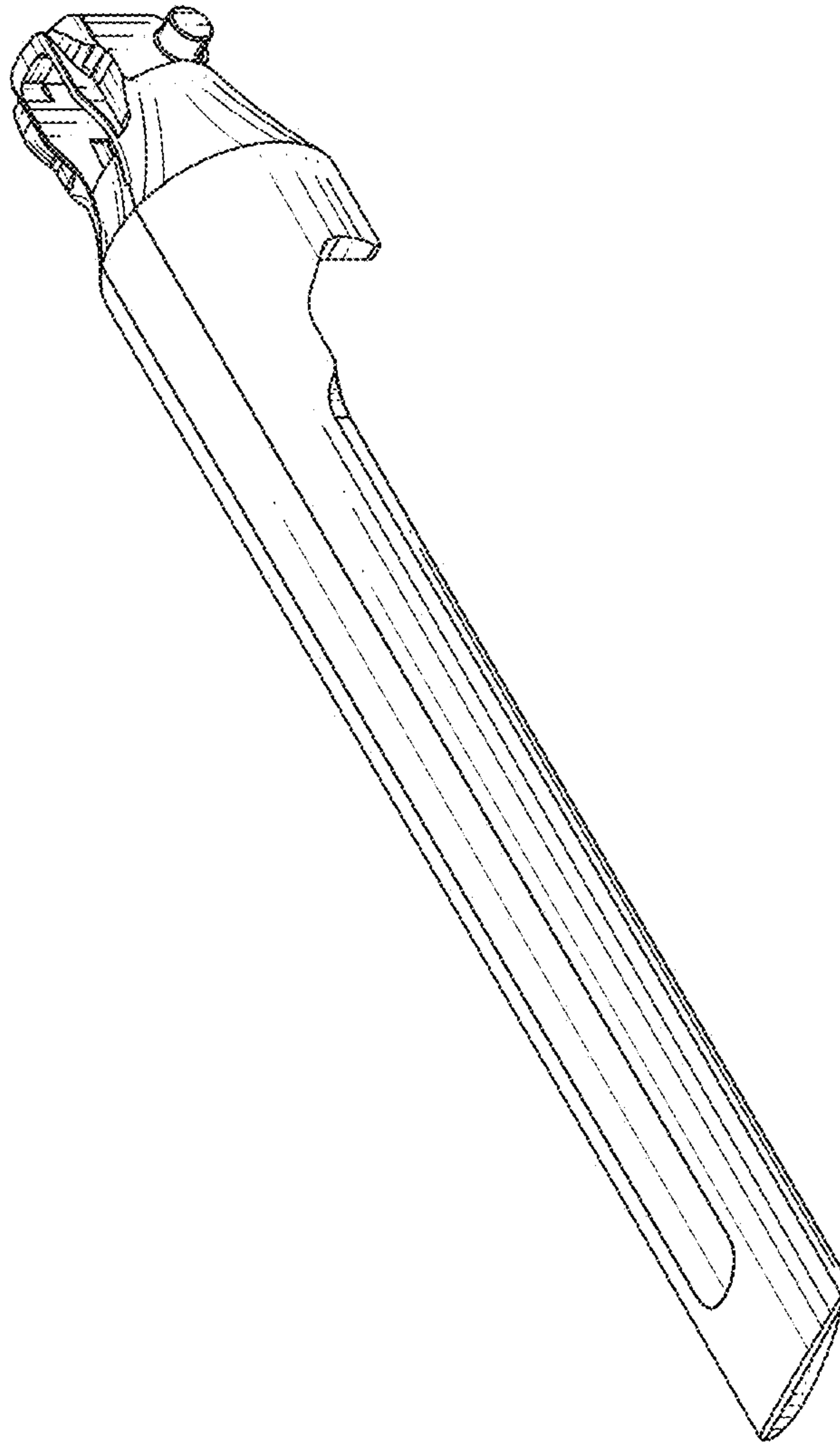

FIG. 1

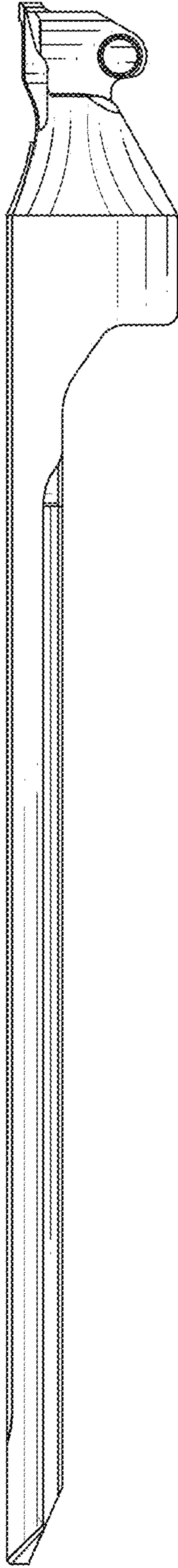

FIG. 2

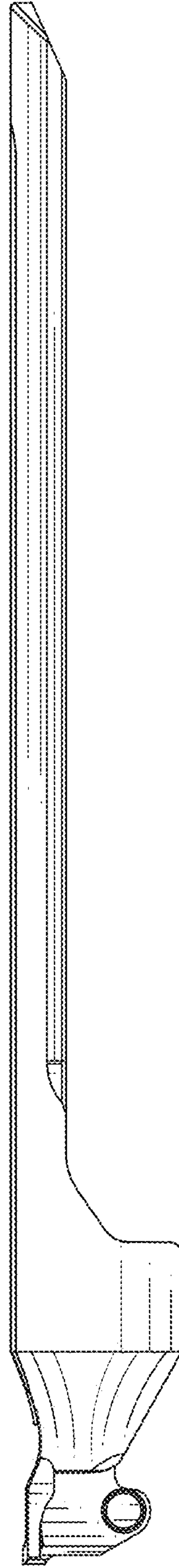

FIG. 3

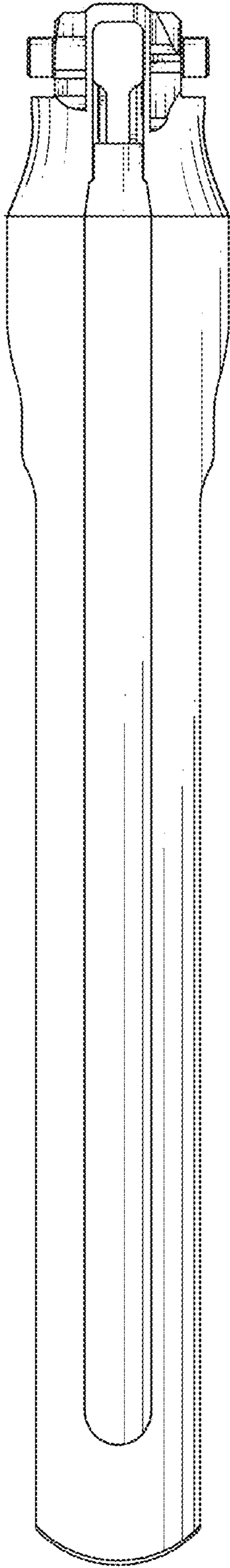

FIG. 4

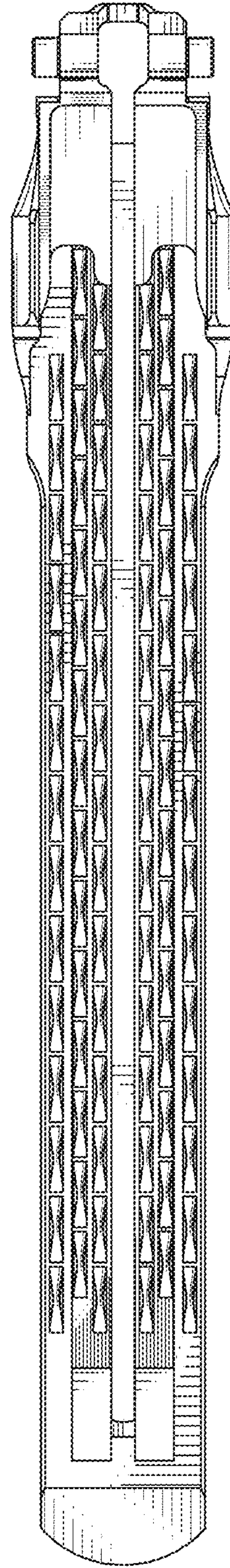

FIG. 5

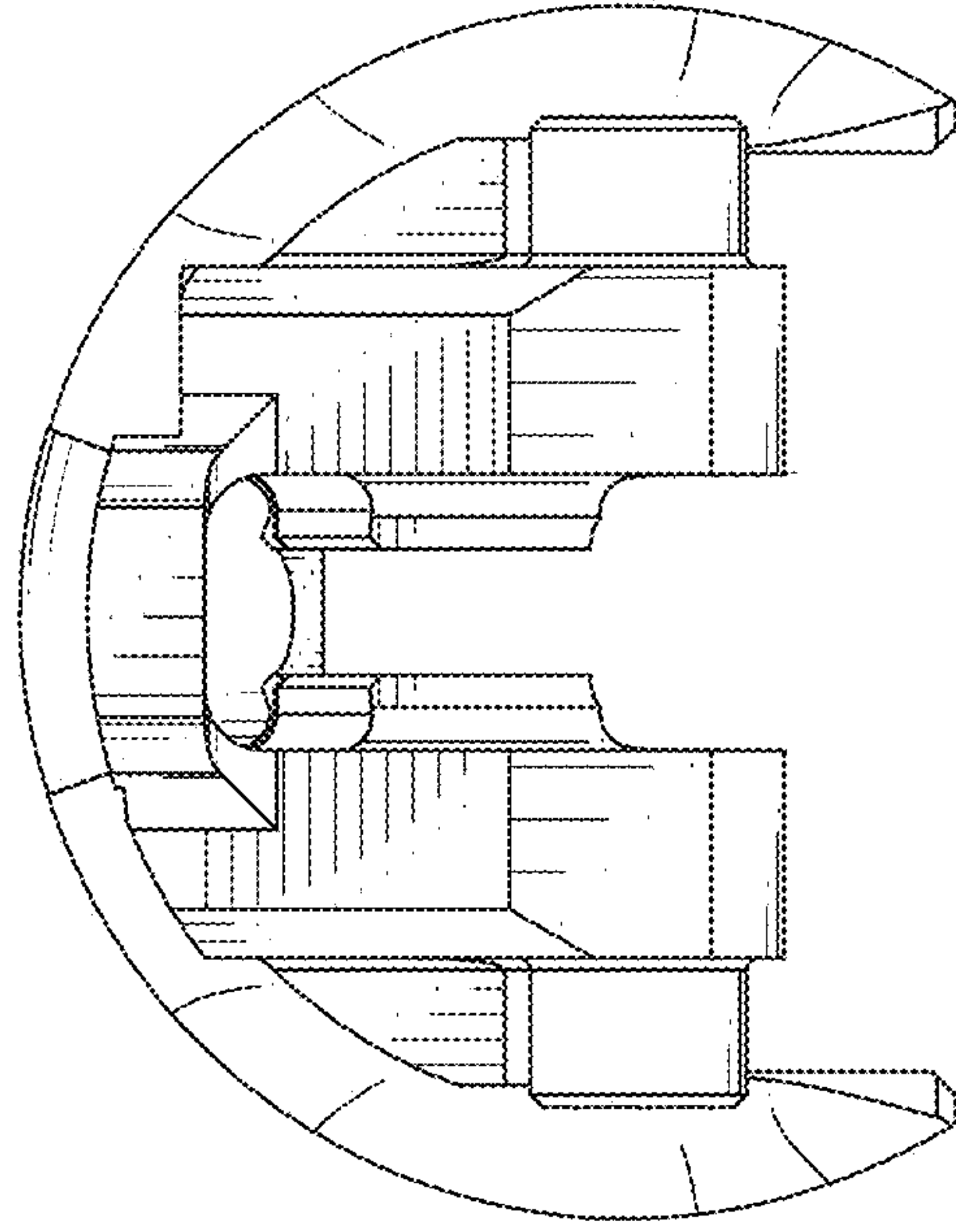

FIG. 6

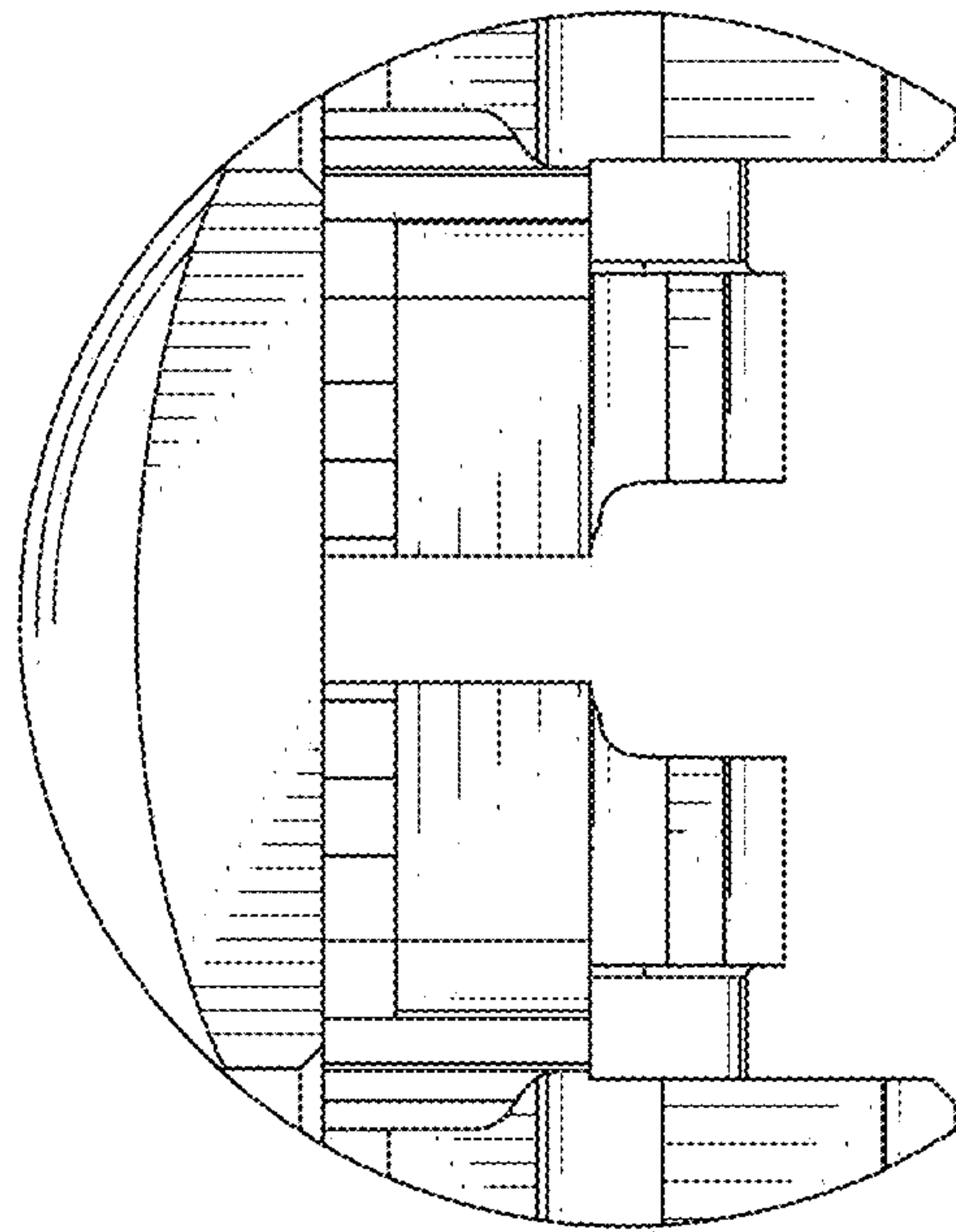

FIG. 7

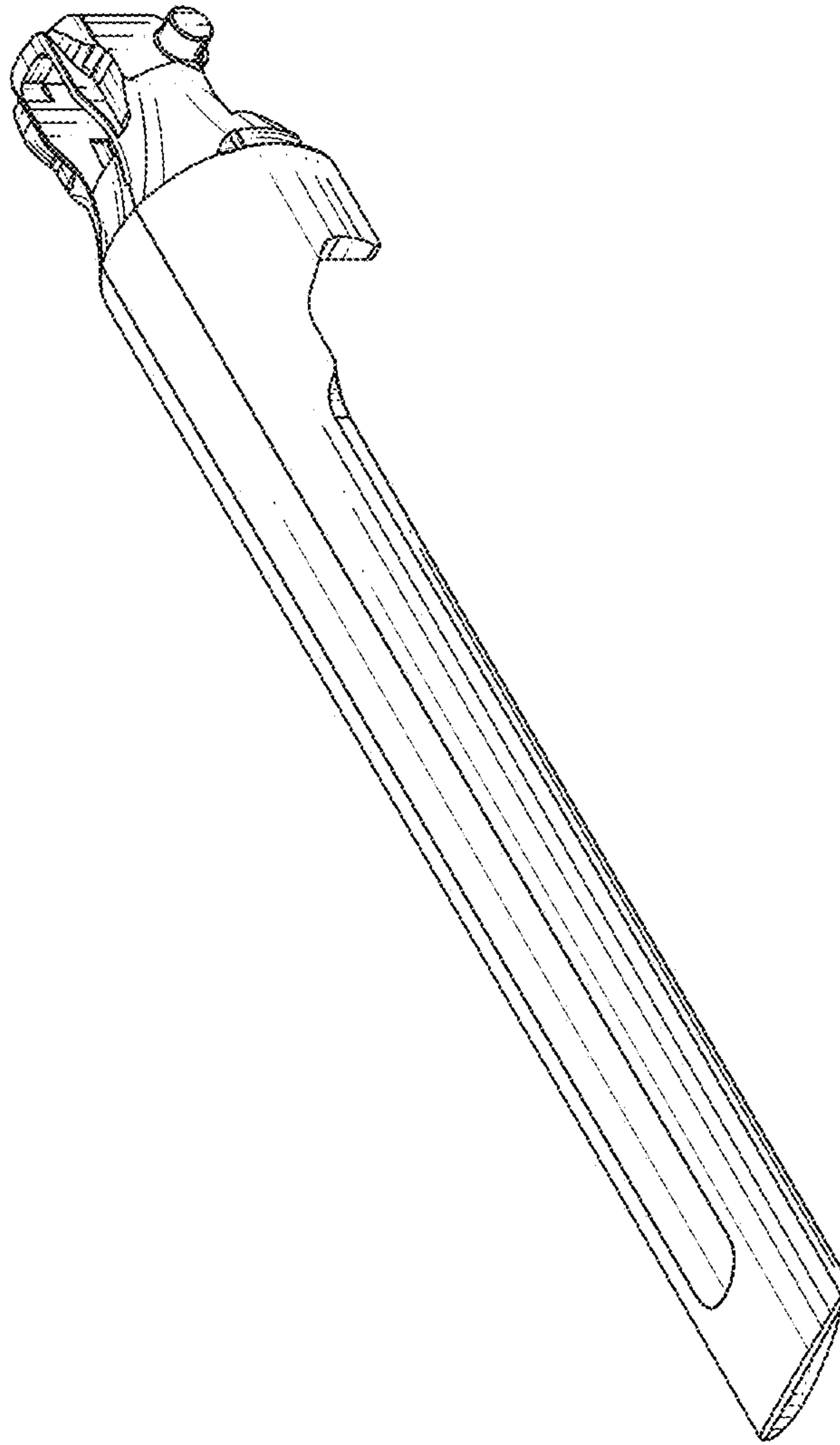

FIG. 8

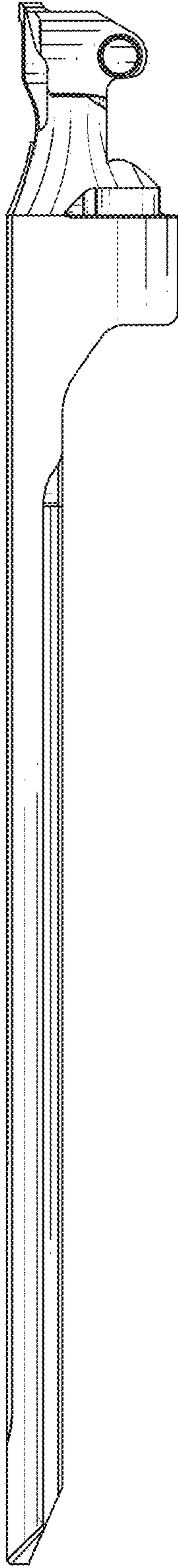

FIG. 9

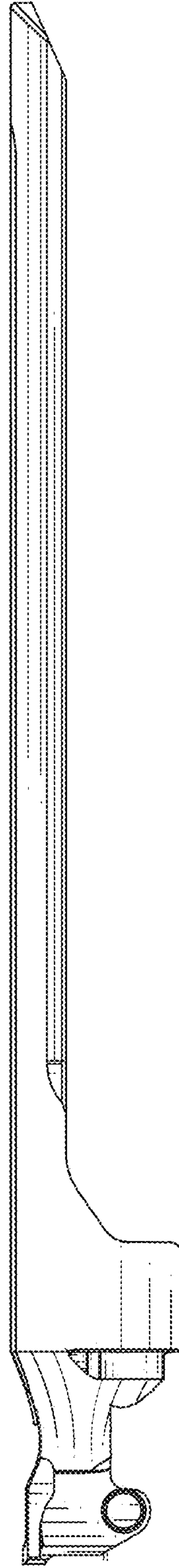

FIG. 10

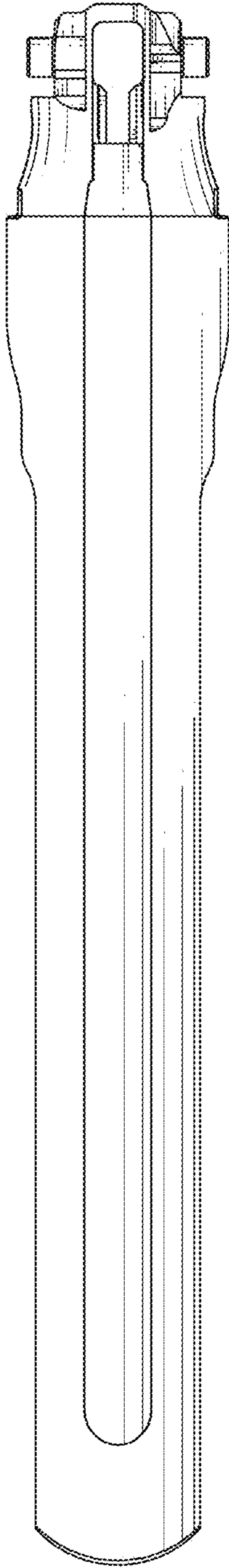

FIG. 11

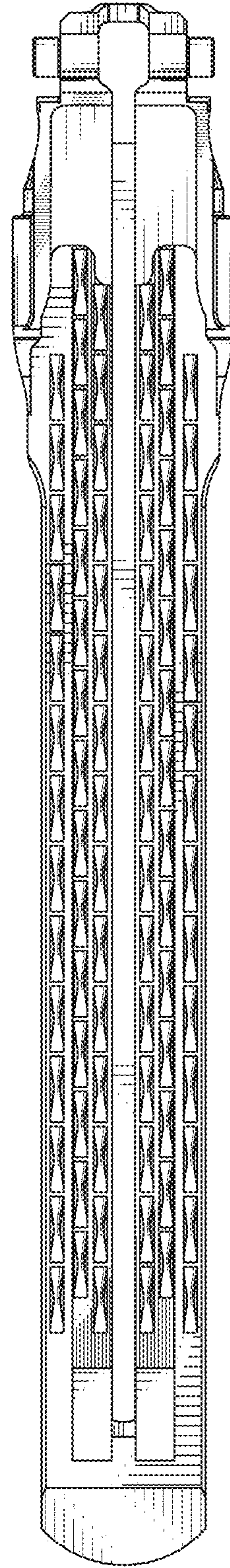

FIG. 12

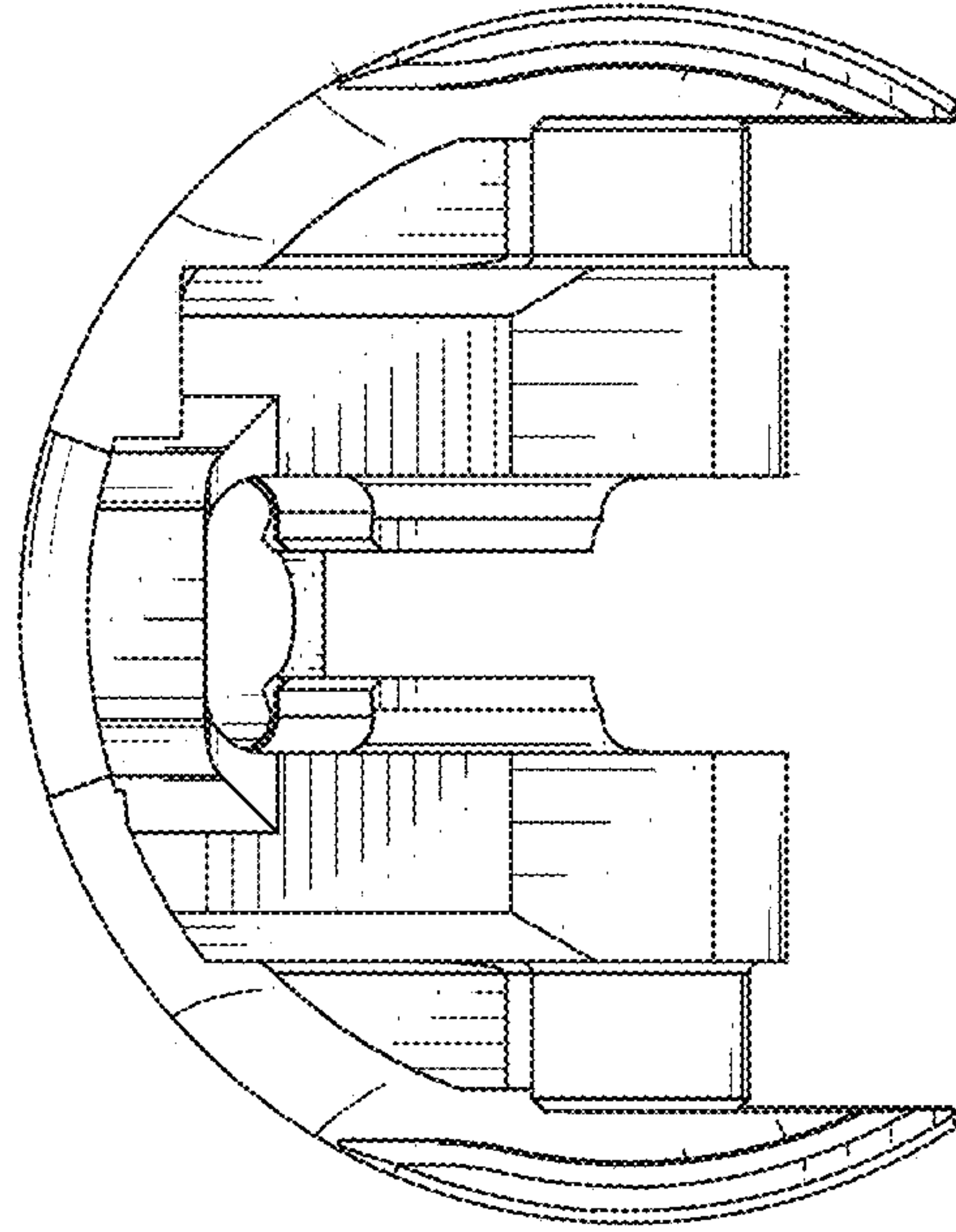

FIG. 13

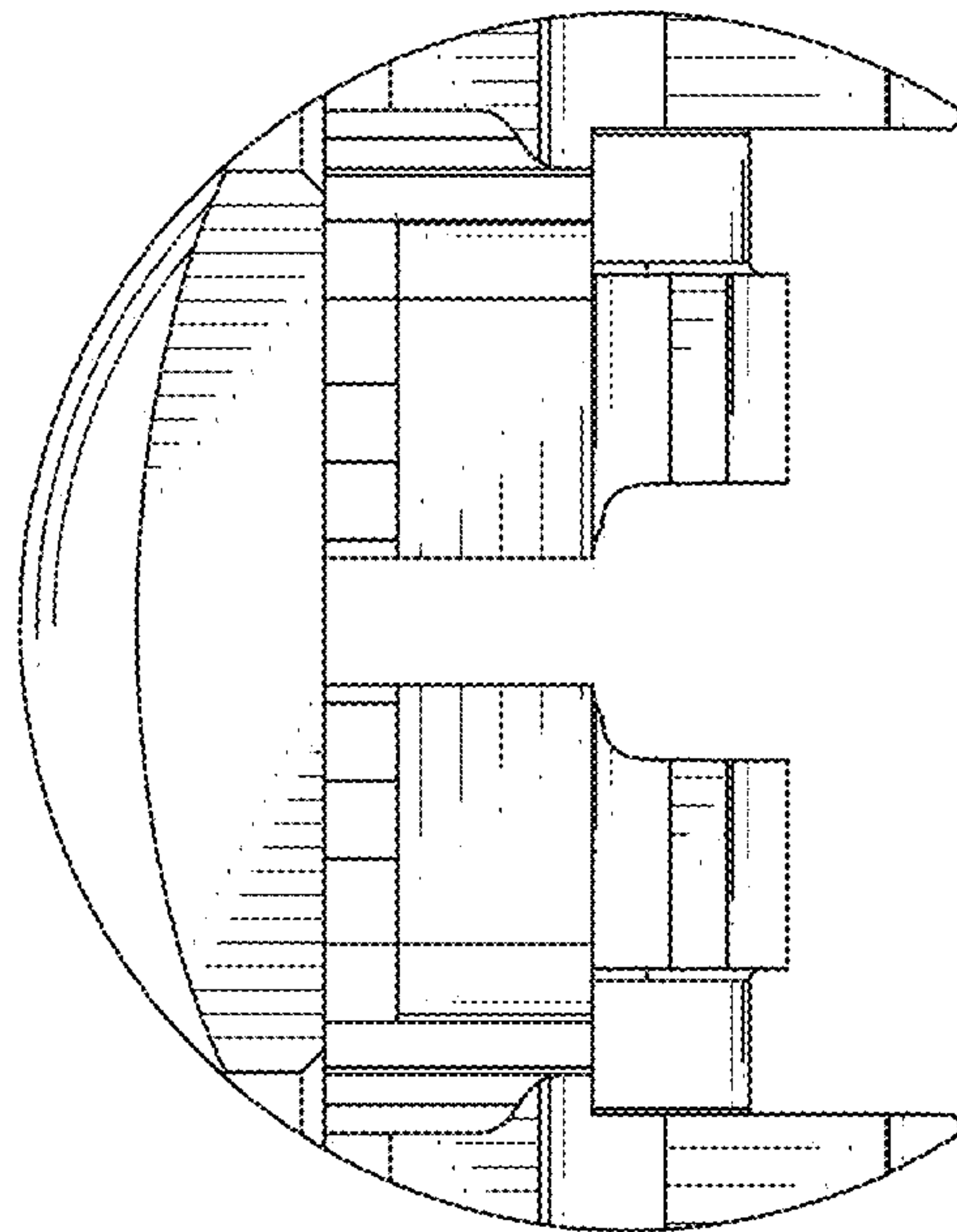

FIG. 14

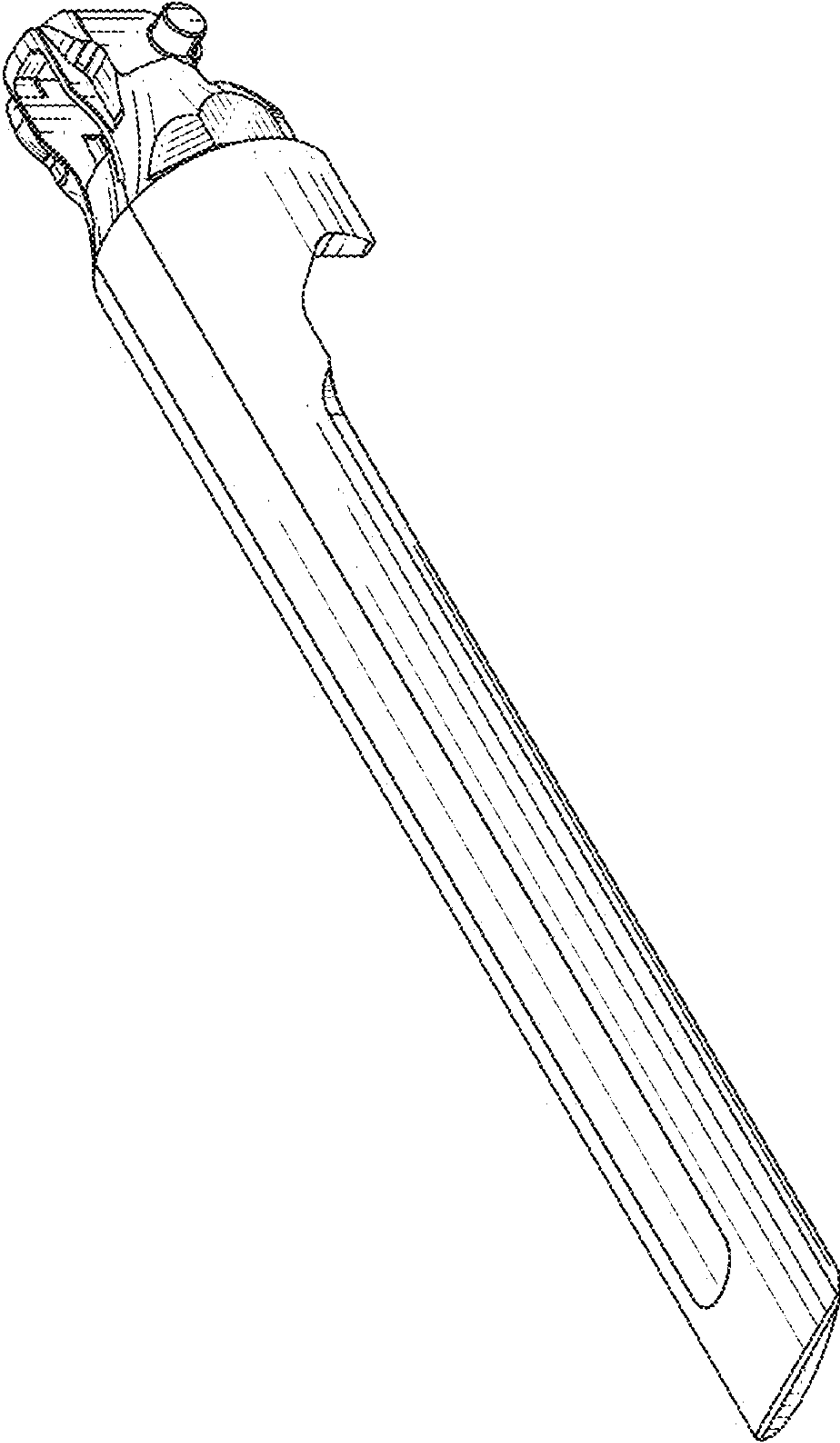

FIG. 15

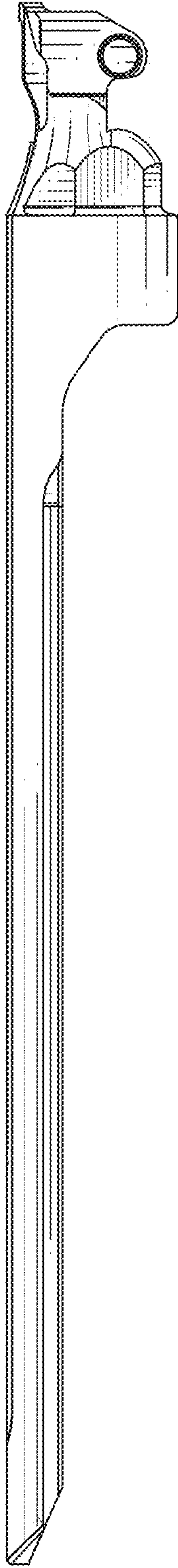

FIG. 16

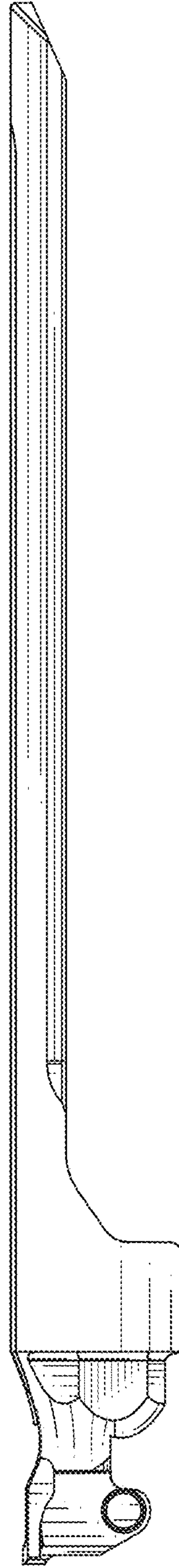

FIG. 17

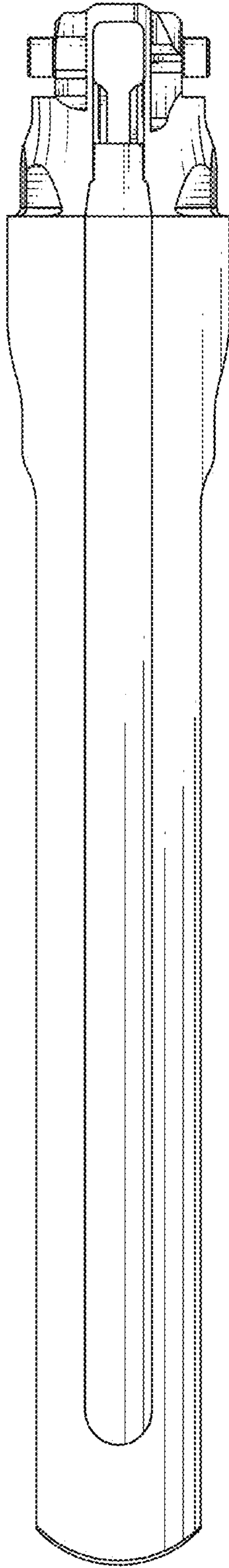

FIG. 18

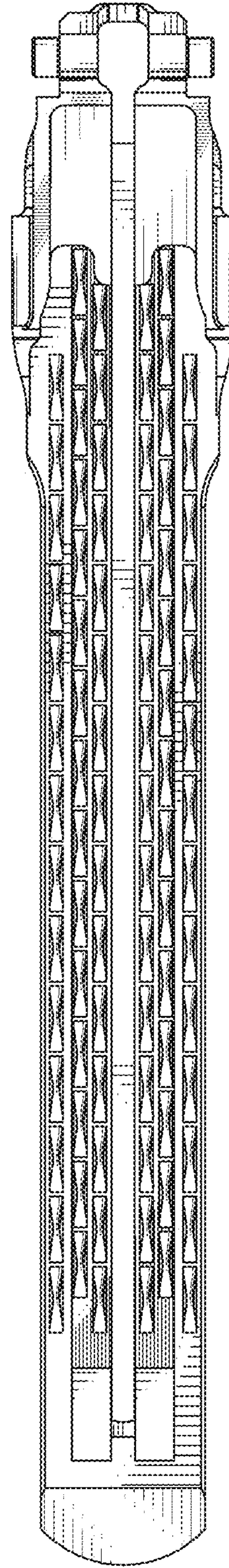

FIG. 19

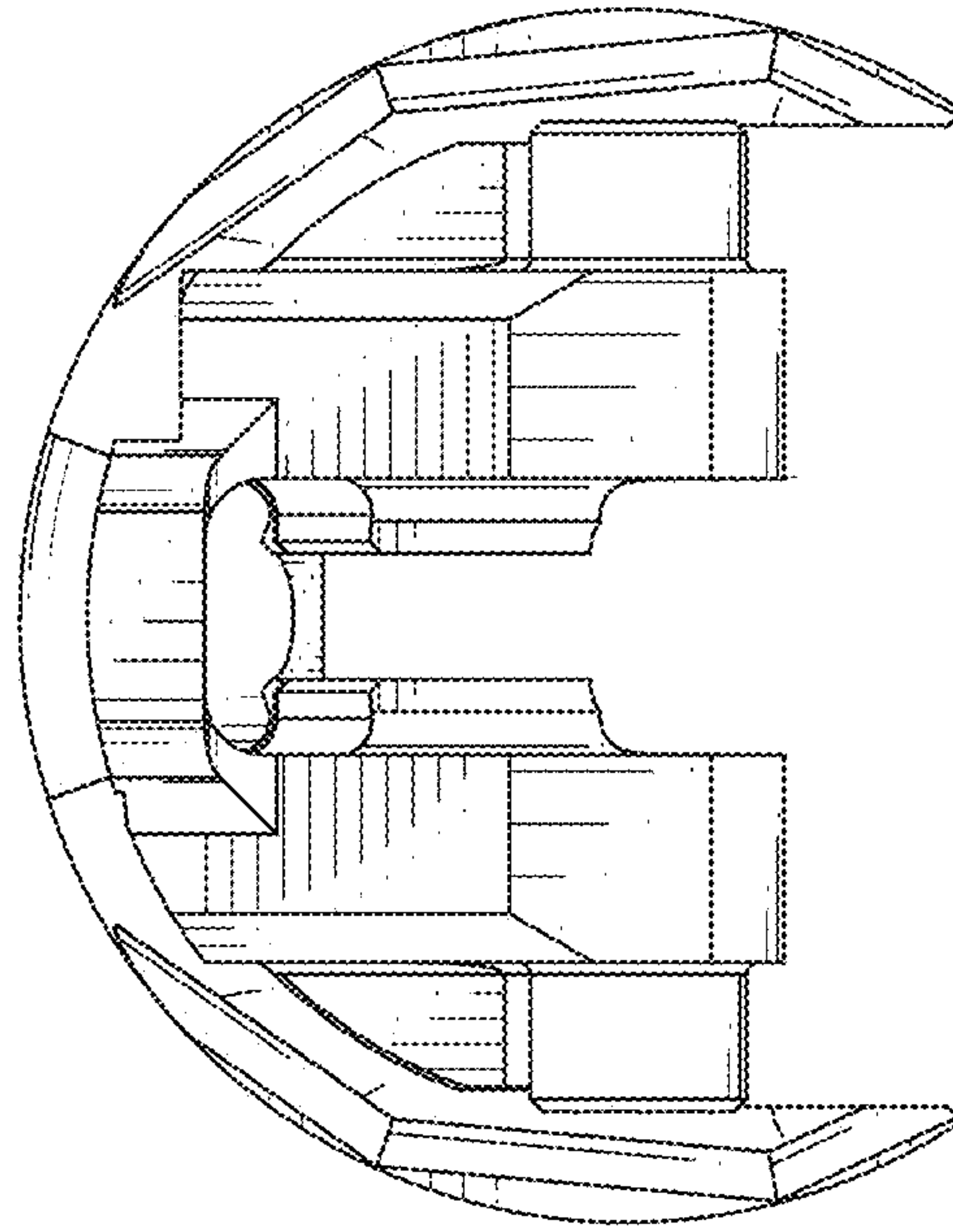

FIG. 20

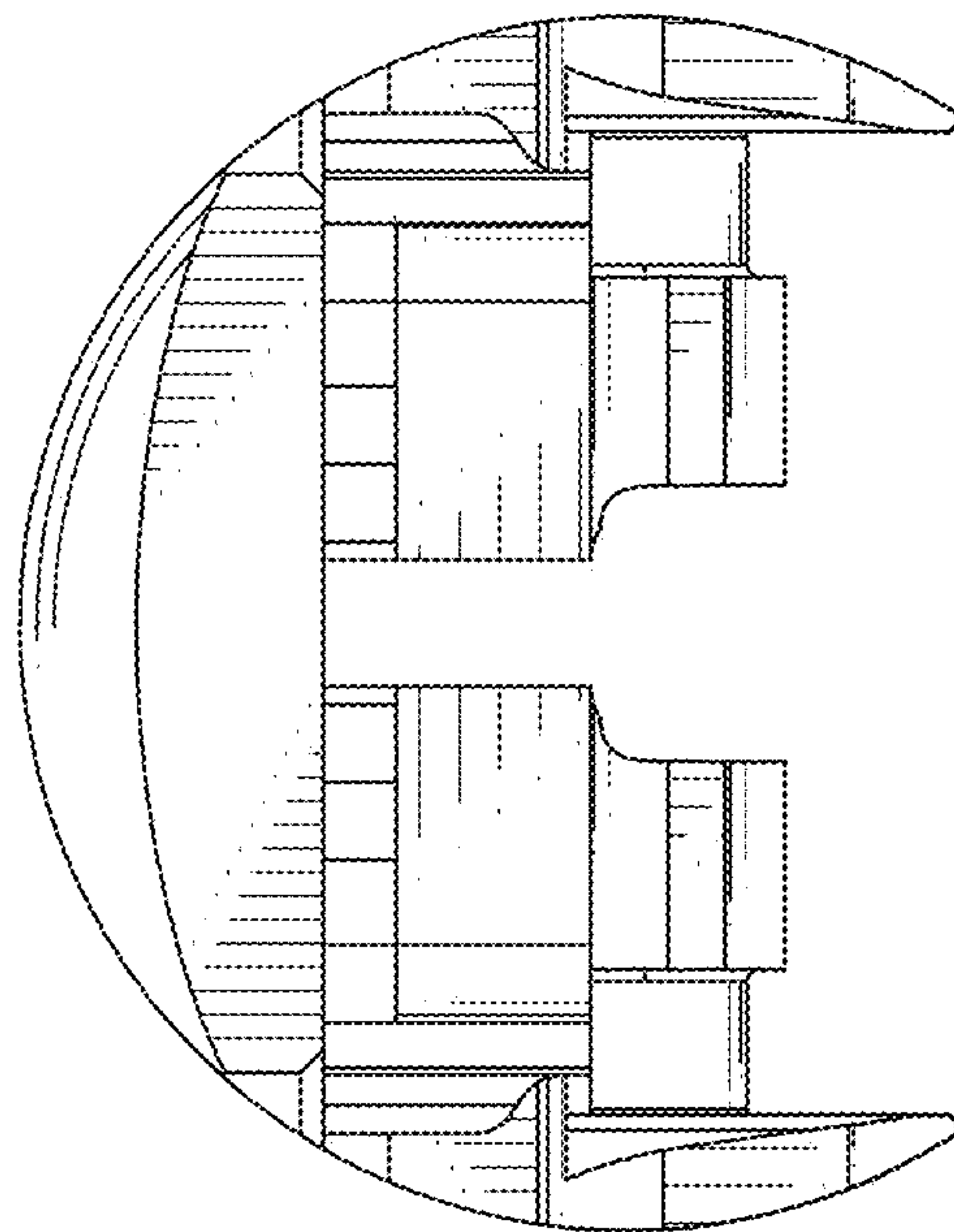

FIG. 21