



US00D914601S

(12) **United States Design Patent** (10) **Patent No.:** **US D914,601 S**  
**Edwards et al.** (45) **Date of Patent:** **\*\* Mar. 30, 2021**

(54) **CASE FOR A SERVOMOTOR**

**DESCRIPTION**

(71) Applicant: **2576150 ONTARIO CORP.**, Toronto (CA)

(72) Inventors: **Jonathan Edwards**, Toronto (CA);  
**Daniel Kitchen**, Woodville (CA)

(73) Assignee: **2576150 ONTARIO CORP.**, Toronto (CA)

(\*\*) Term: **15 Years**

(21) Appl. No.: **29/688,171**

(22) Filed: **Apr. 18, 2019**

(30) **Foreign Application Priority Data**

Oct. 18, 2018 (CA) ..... CA 184262

(51) **LOC (13) Cl.** ..... **13-01**

(52) **U.S. Cl.**  
USPC ..... **D13/112**

(58) **Field of Classification Search**

USPC ..... D13/101, 110, 112, 113, 114, 118, 120,  
D13/122, 174, 184, 199; D15/5, 143,  
D15/148, 199; D23/233; D12/180  
(Continued)

(56) **References Cited**

U.S. PATENT DOCUMENTS

4,933,582 A \* 6/1990 Hata ..... H02K 1/17  
310/154.14  
4,988,905 A \* 1/1991 Tolmie, Jr. .... H02K 29/06  
310/68 B

(Continued)

*Primary Examiner* — Derrick E Holland

(74) *Attorney, Agent, or Firm* — Tucker Ellis LLP

(57) **CLAIM**

The ornamental design for a case for a servomotor, as shown and described.

FIG. 1 is a rear-left-top isometric view of a case for a servomotor showing our new design, a rear-right-top isometric view thereof being a mirror image;

FIG. 2 is a front view thereof, a rear view thereof being identical thereto;

FIG. 3 is a left side view thereof, a right side view thereof being a mirror image;

FIG. 4 is a top view thereof, a bottom view thereof being identical thereto;

FIG. 5 is a front-left-top isometric view of another embodiment of the case for a servomotor, a front-right-top isometric view thereof being a mirror image;

FIG. 6 is a front view thereof, a rear view thereof being identical thereto;

FIG. 7 is a left side view thereof, a right side view thereof being a mirror image;

FIG. 8 is a top view thereof, a bottom view thereof being identical thereto;

FIG. 9 is a bottom view of another embodiment of the case for a servomotor, isometric, front, rear, left side, right side and top views being the same as those from the embodiment of FIGS. 1-4 or the embodiment of FIGS. 5-8.

FIG. 10 is a rear-left-top isometric view of another embodiment of the case for a servomotor, a rear-right-top isometric view thereof being a mirror image;

FIG. 11 is a front view thereof, a rear view thereof being identical thereto;

FIG. 12 is a left side view thereof, a right side view thereof being a mirror image;

FIG. 13 is a top view thereof, a bottom view thereof being identical thereto;

FIG. 14 is a rear-left-top isometric view of another embodiment of the case for a servomotor, a rear-right-top isometric view thereof being a mirror image;

FIG. 15 is a front view thereof, a rear view thereof being identical thereto;

FIG. 16 is a left side view thereof, a right side view thereof being a mirror image;

FIG. 17 is a top view thereof, a bottom view thereof being identical thereto; and,

FIG. 18 is a bottom view of another embodiment of the case for a servomotor, isometric, front, rear, left side, right side

(Continued)

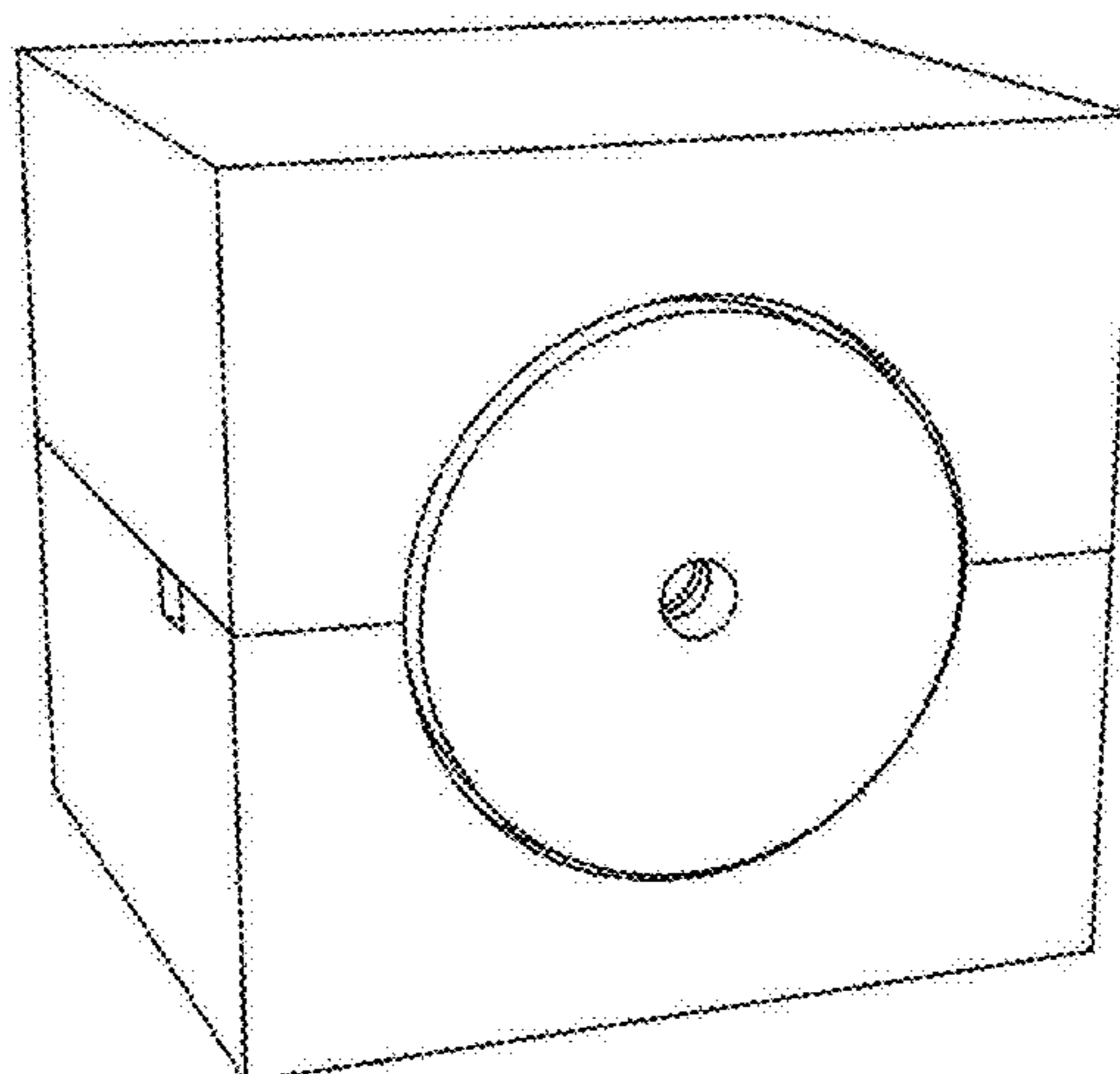

and top views being the same as those from the embodiment of FIGS. 10-13 or the embodiment of FIGS. 14-17.

The broken lines are for the purpose of illustrating portions of the case for a servomotor and form no part of the claimed design. The case for a servomotor has been shown with symbolic breaks identified by brackets in FIGS. 10-18. The appearance of any portion of the article between the break lines forms no part of the claimed design.

**1 Claim, 10 Drawing Sheets**

(58) **Field of Classification Search**

CPC ..... H02K 5/00; H02K 5/148; H02K 5/225;  
H02K 11/026; H02K 11/40; H02K 7/003;  
H01R 39/38; F16D 41/04; F16D 65/14;  
F16D 2125/40; F16D 2125/48; F16D  
2001/102; F16D 2001/103; F16D 1/108

See application file for complete search history.

(56) **References Cited**

U.S. PATENT DOCUMENTS

D397,992	S	*	9/1998	Shimomura	.....	D13/112
D573,091	S	*	7/2008	Shih	.....	D13/112
D628,154	S	*	11/2010	Veeh	.....	D13/112
D694,186	S	*	11/2013	Terashita	.....	D13/112
D731,449	S	*	6/2015	Norman	.....	D13/184

\* cited by examiner

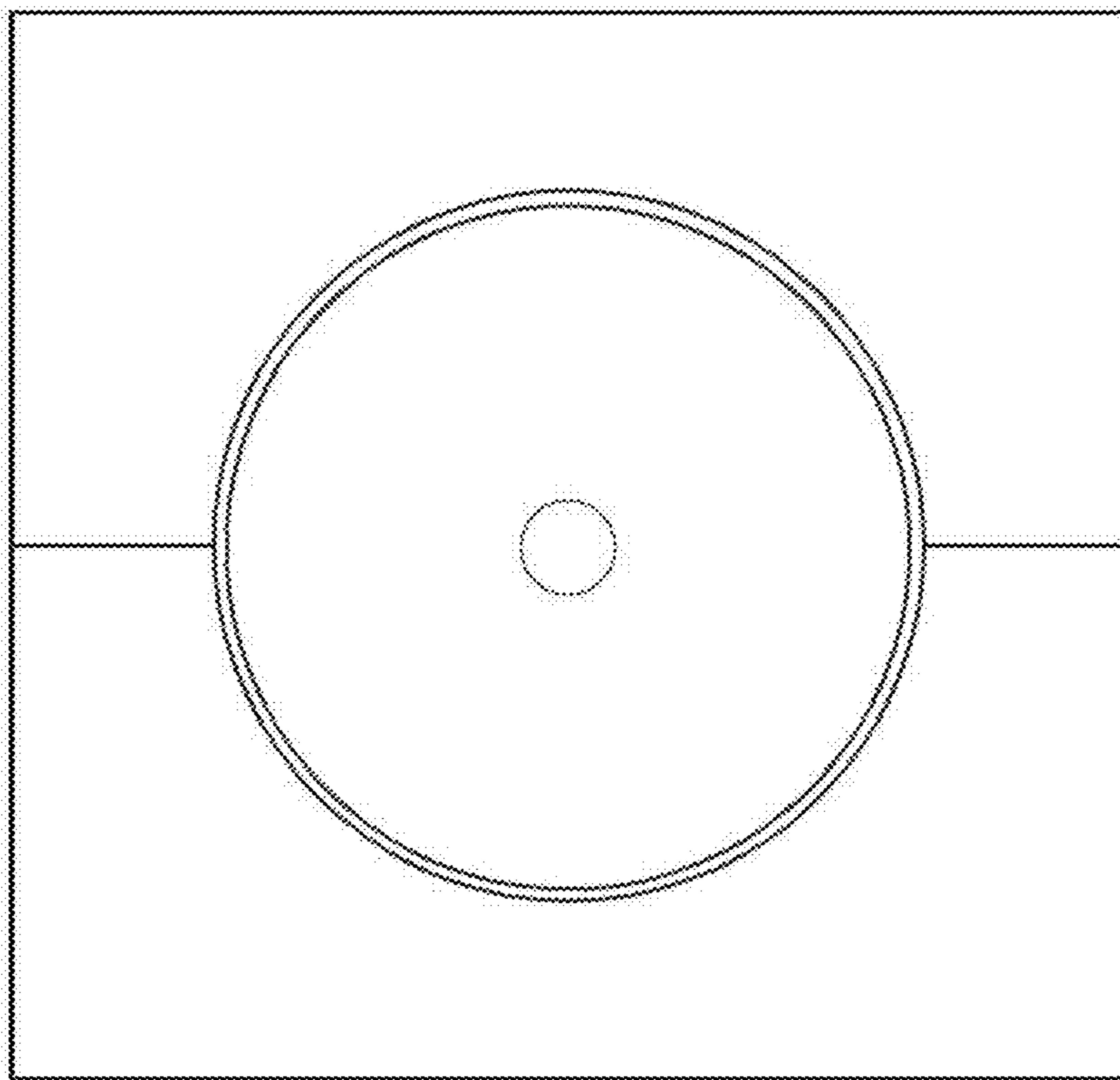
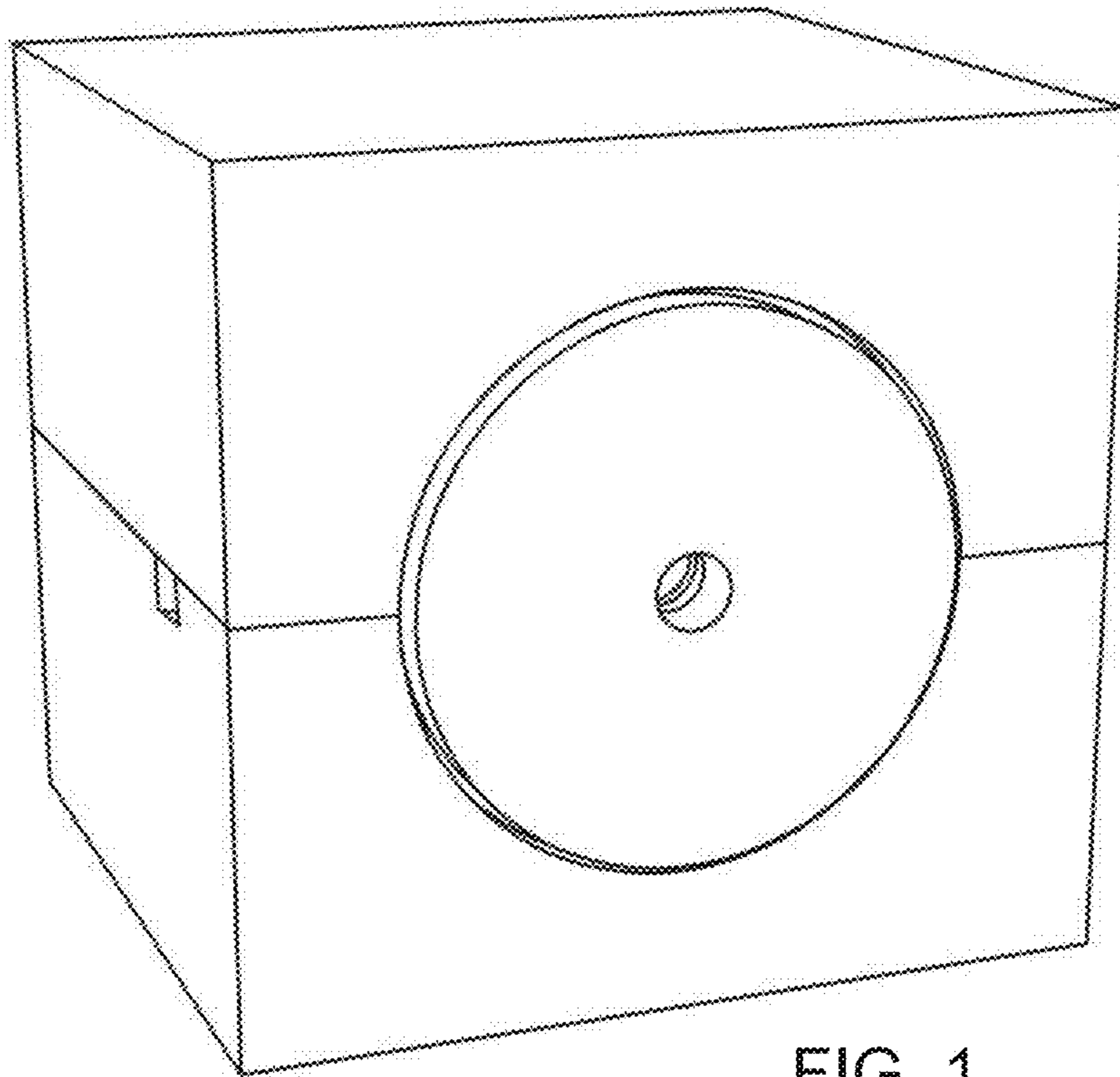

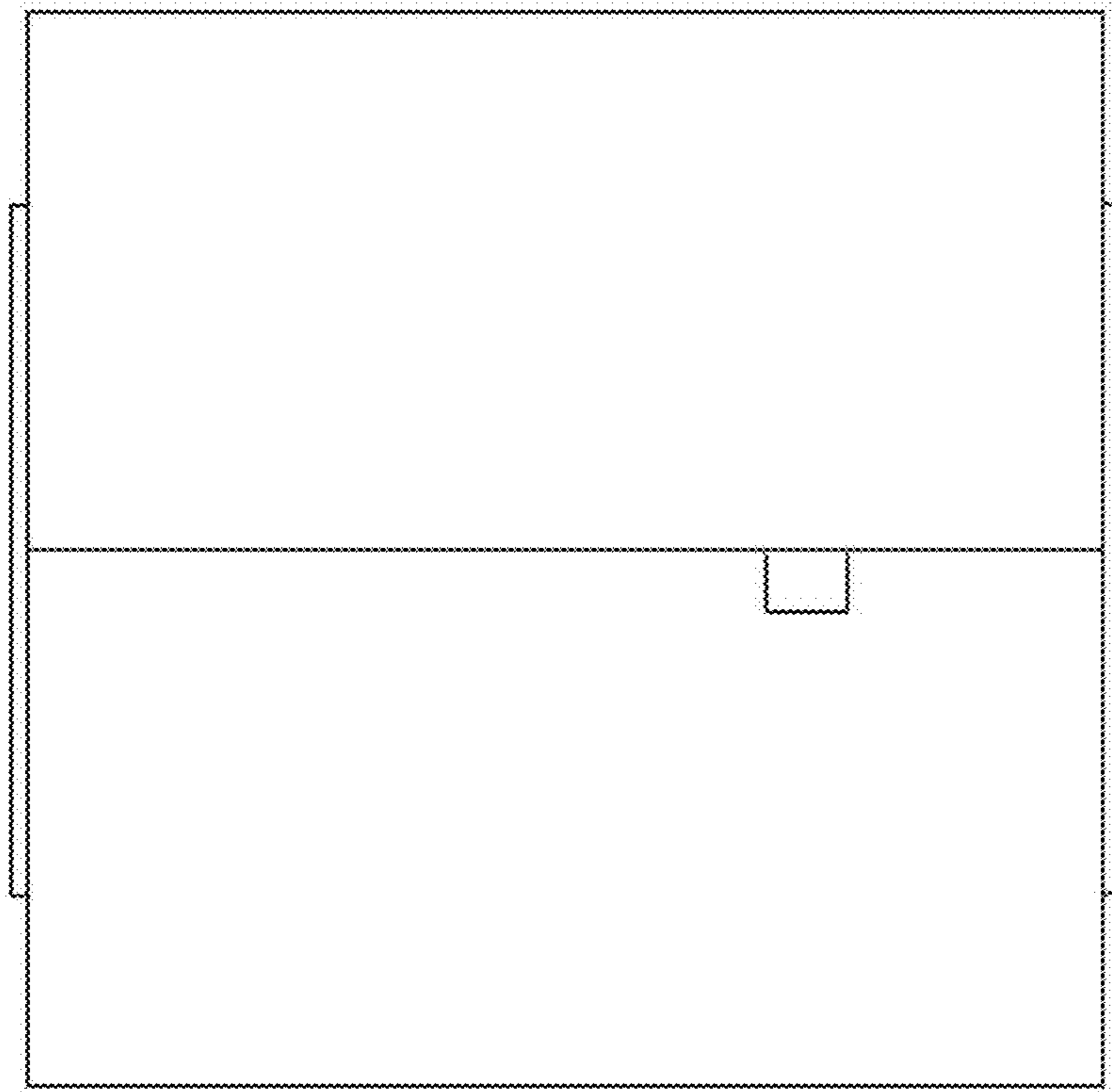

FIG. 3

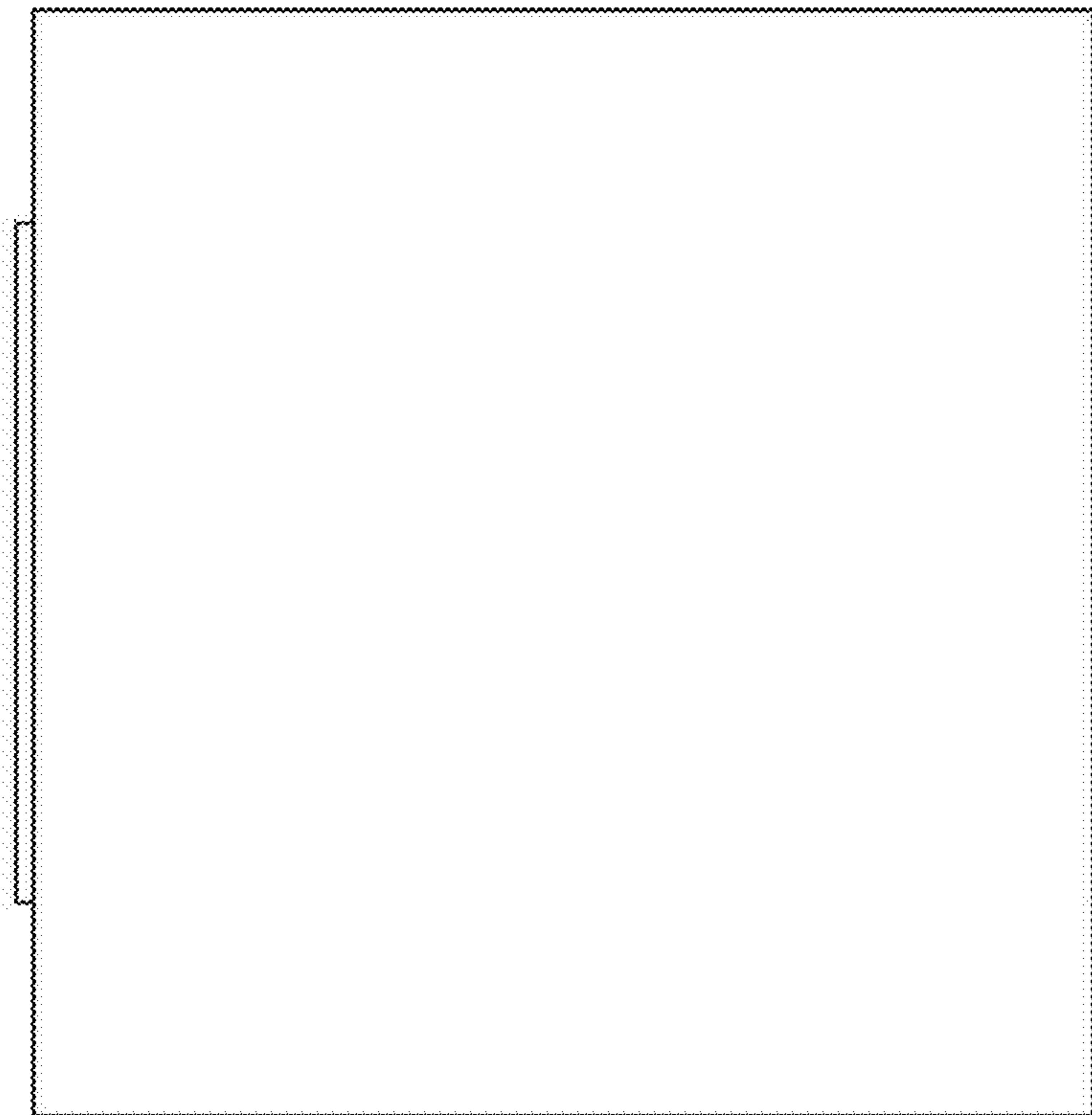

FIG. 4

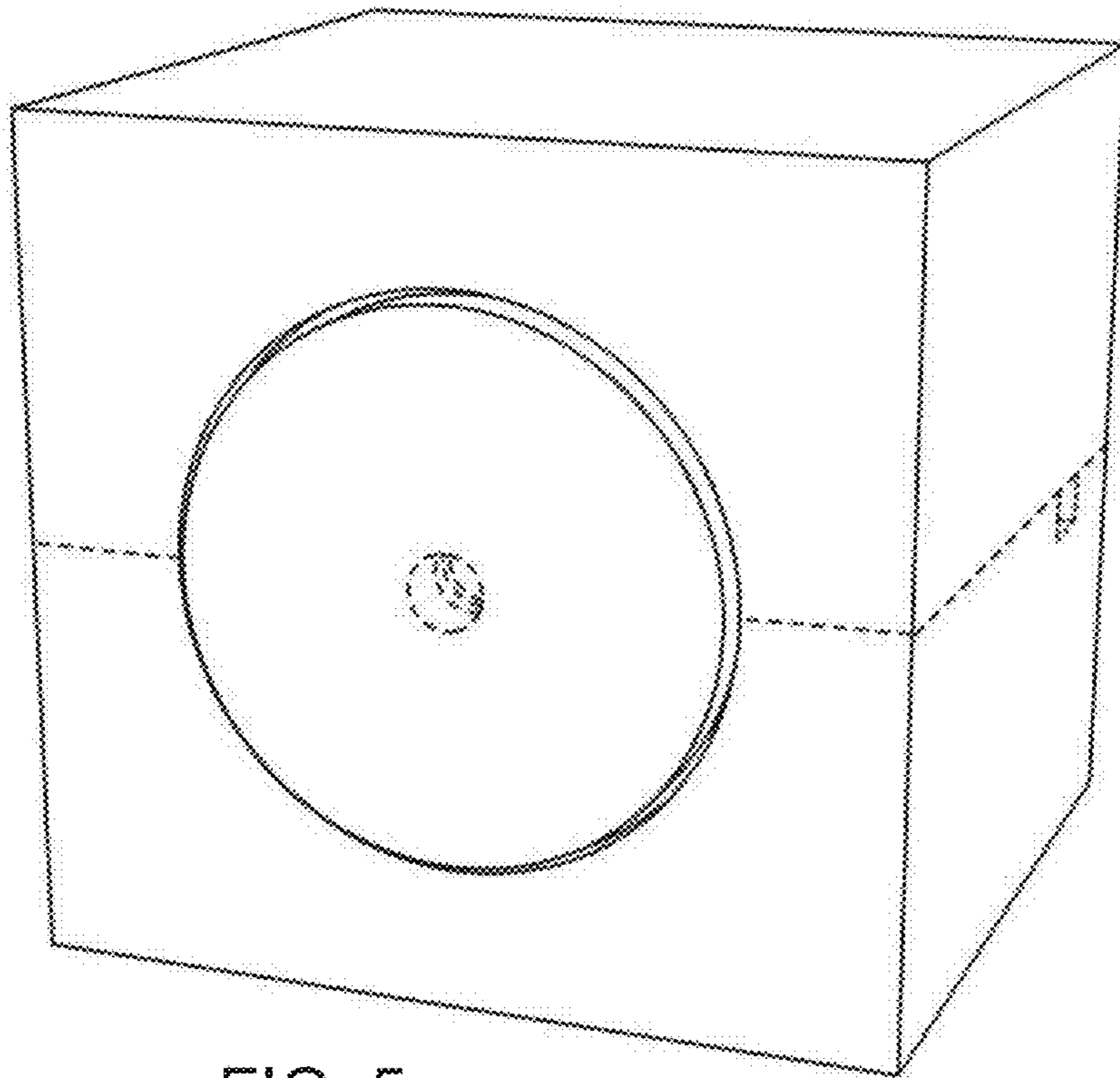

FIG. 5

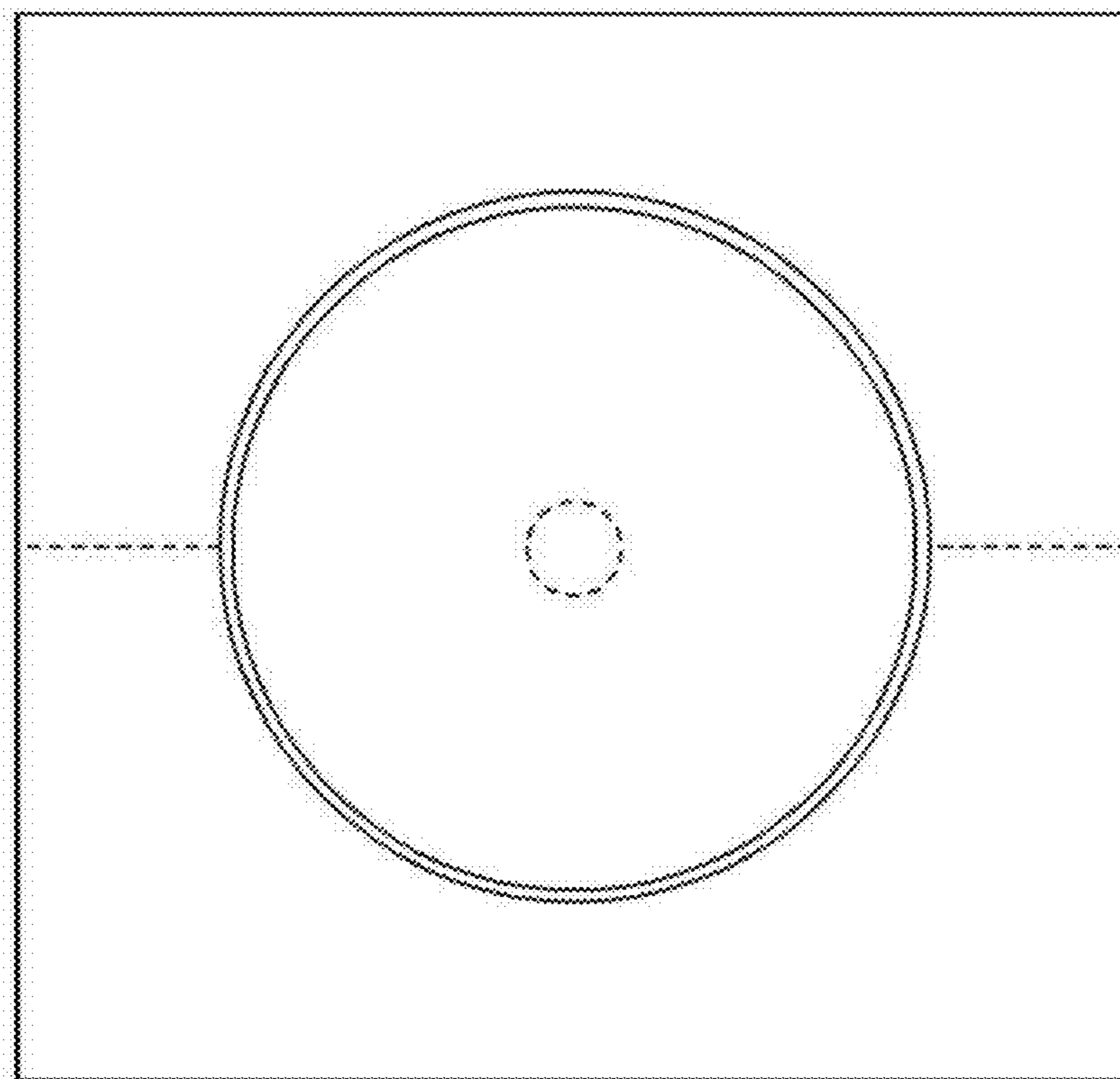

FIG. 6

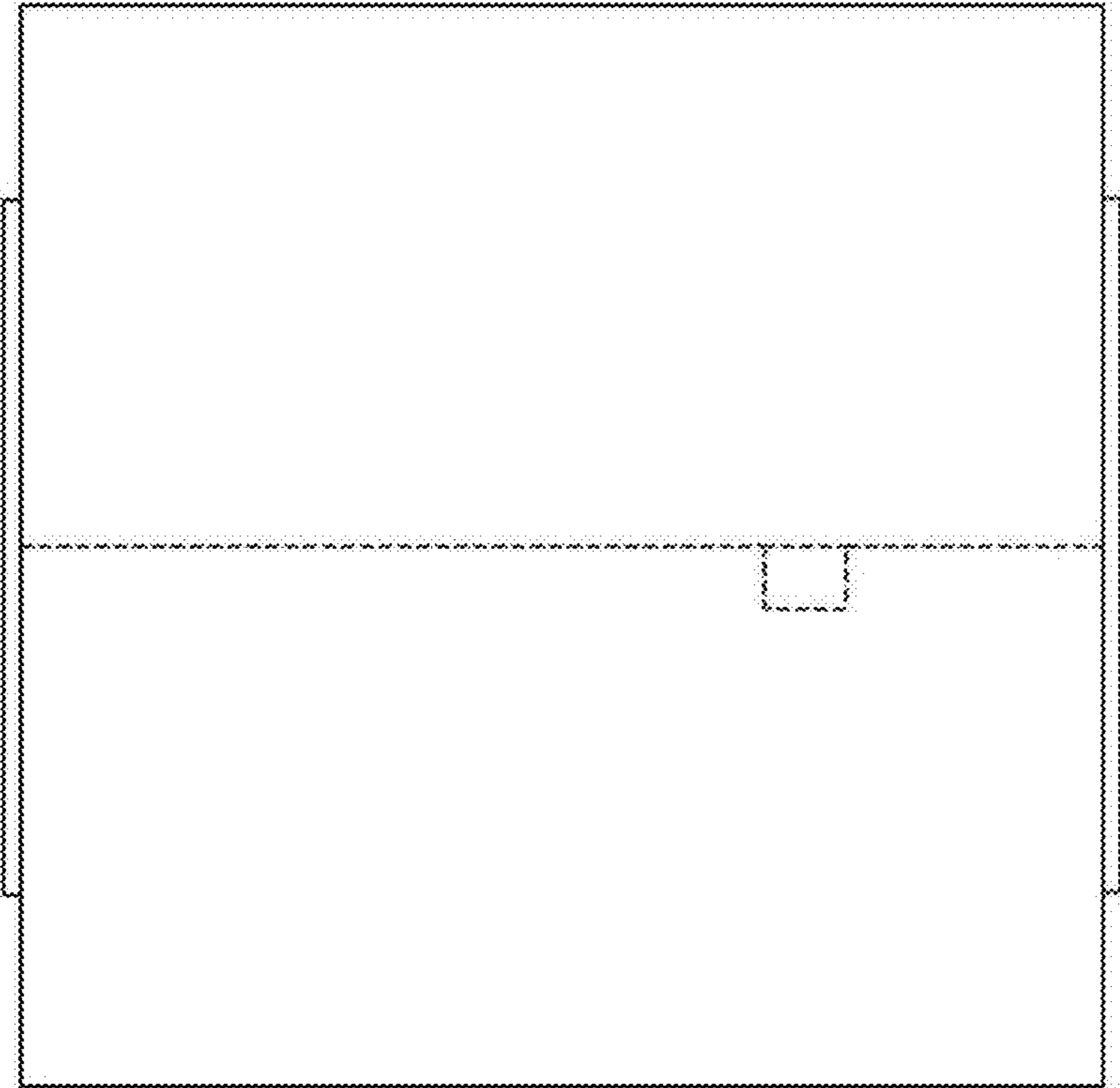

FIG. 7

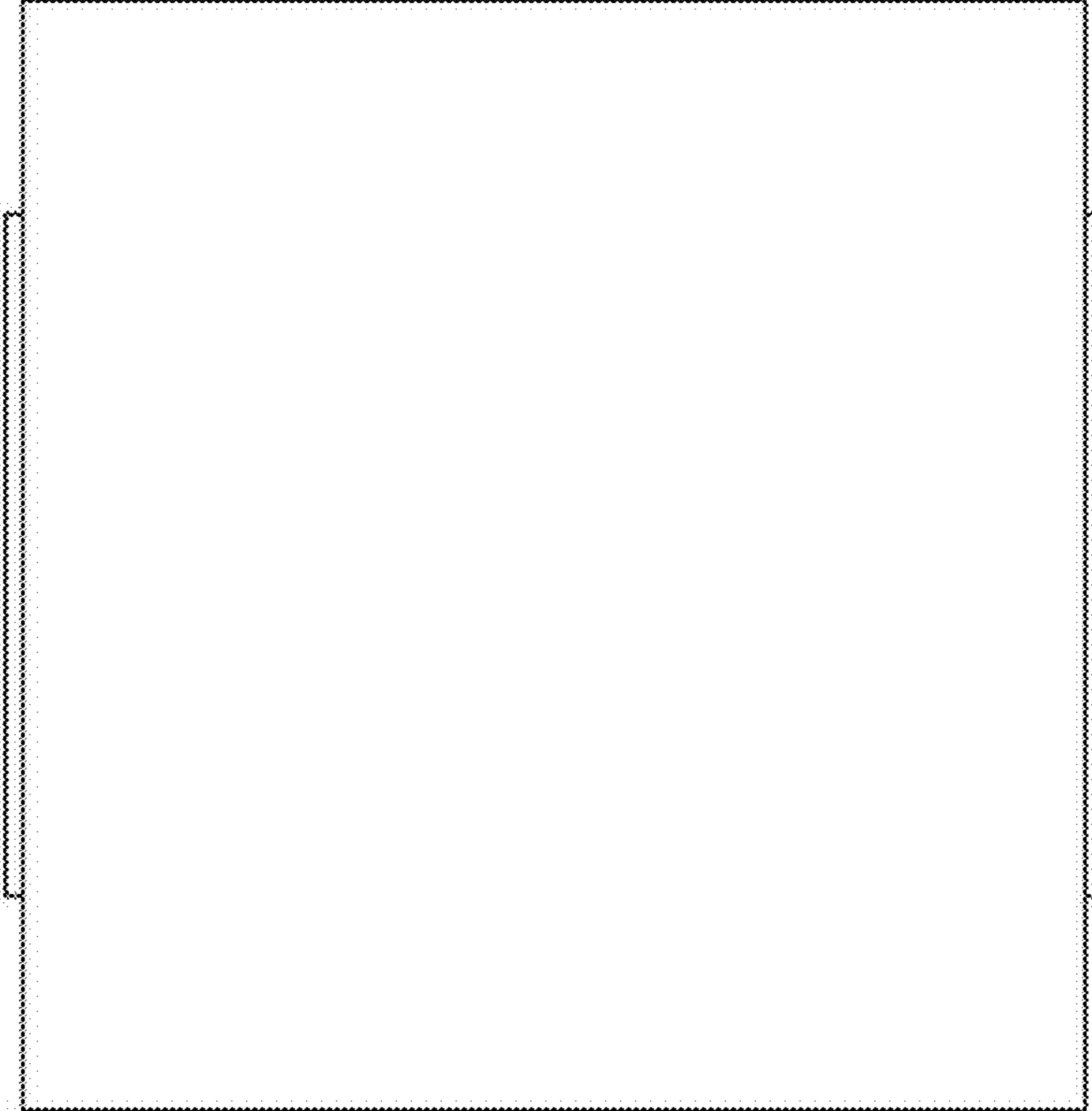

FIG. 8

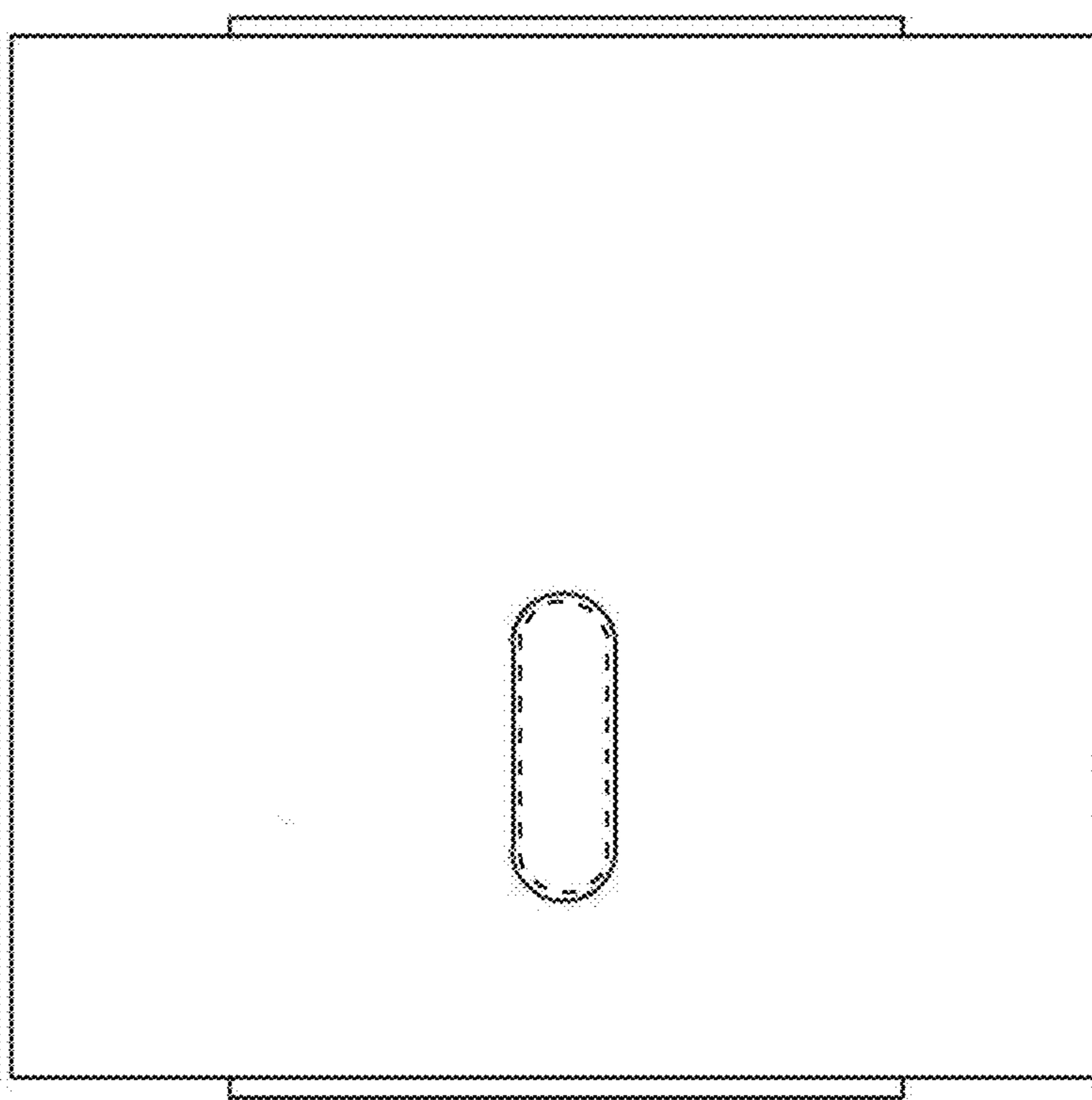

FIG. 9

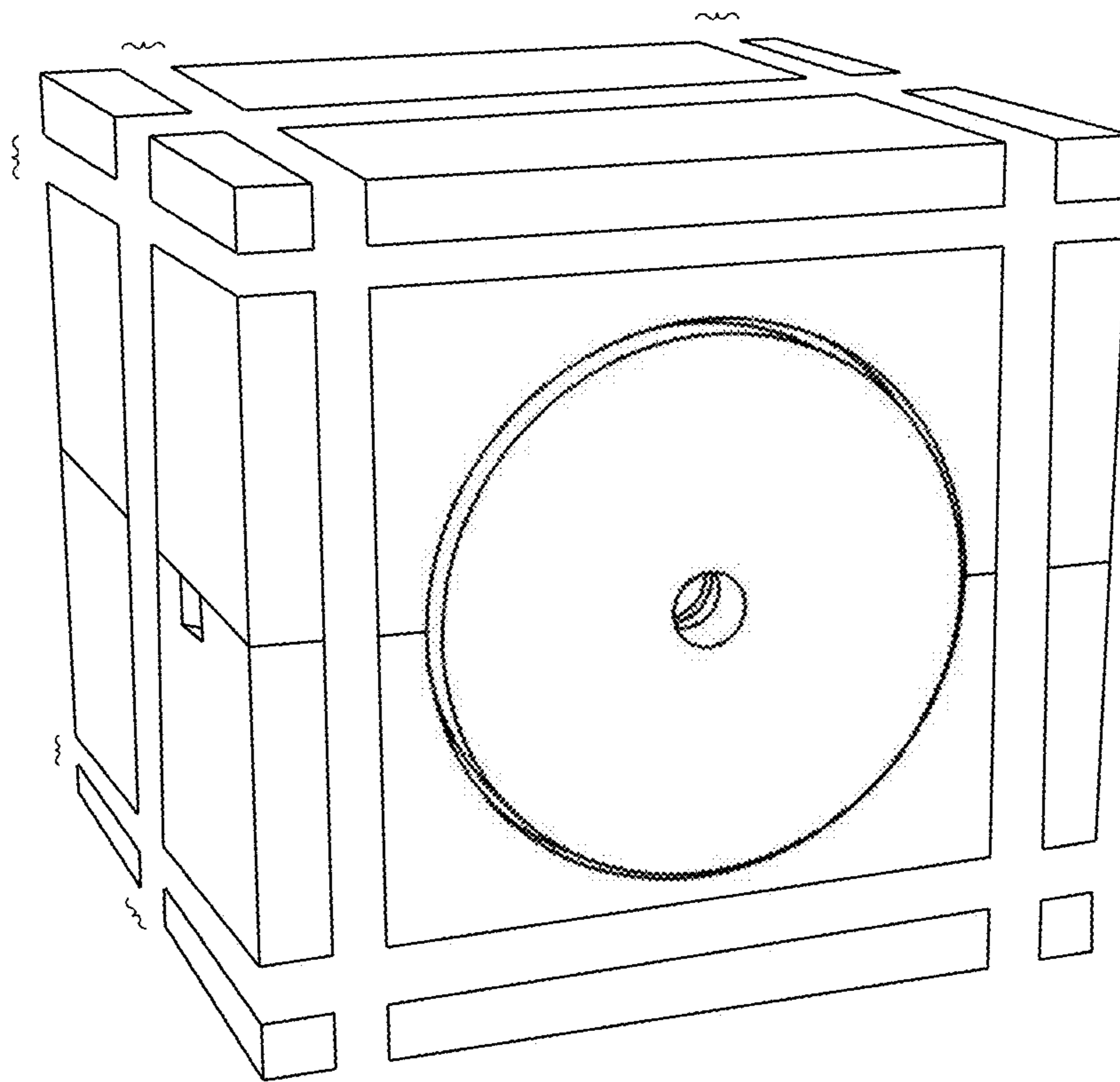

FIG. 10

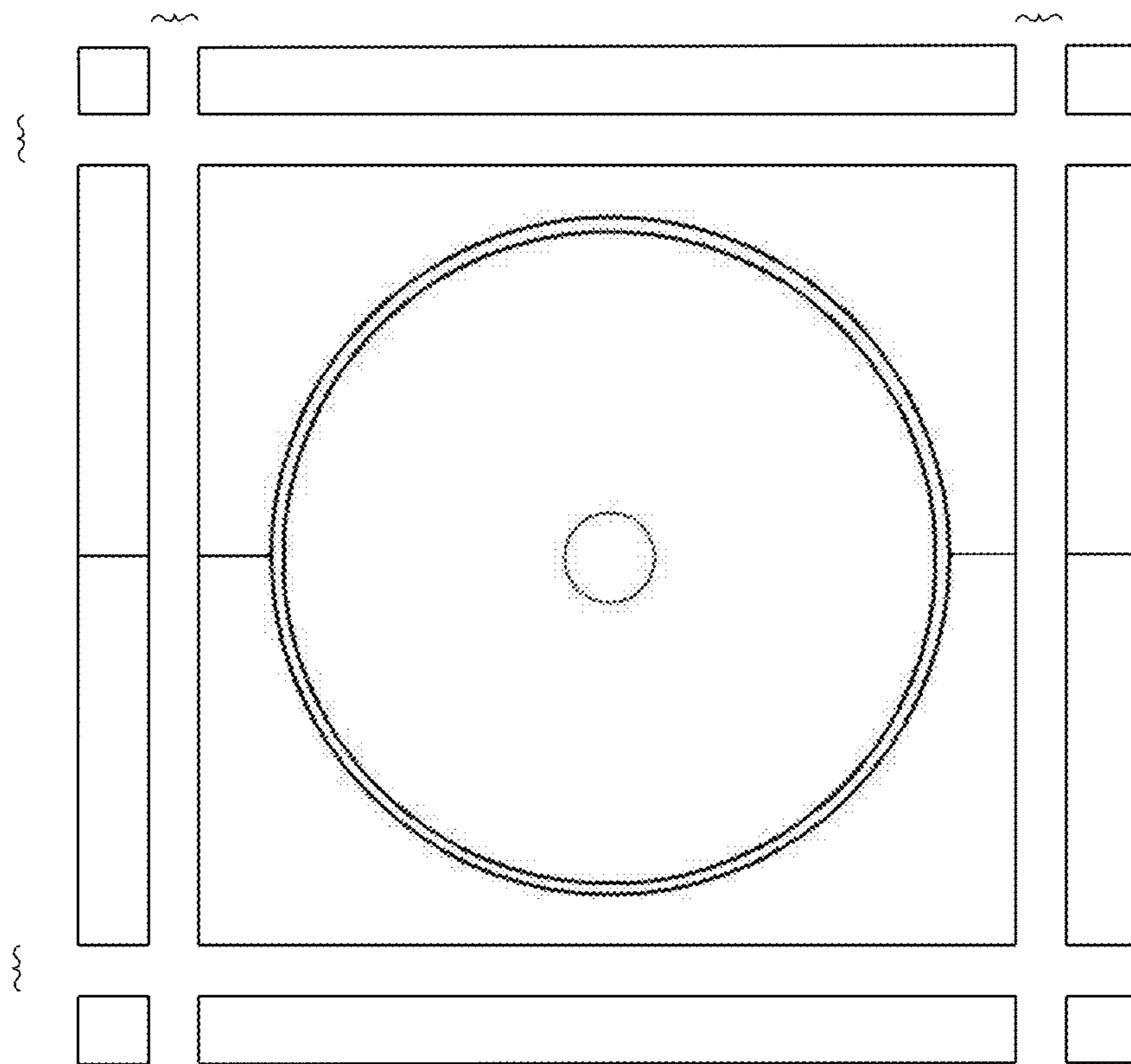

FIG. 11



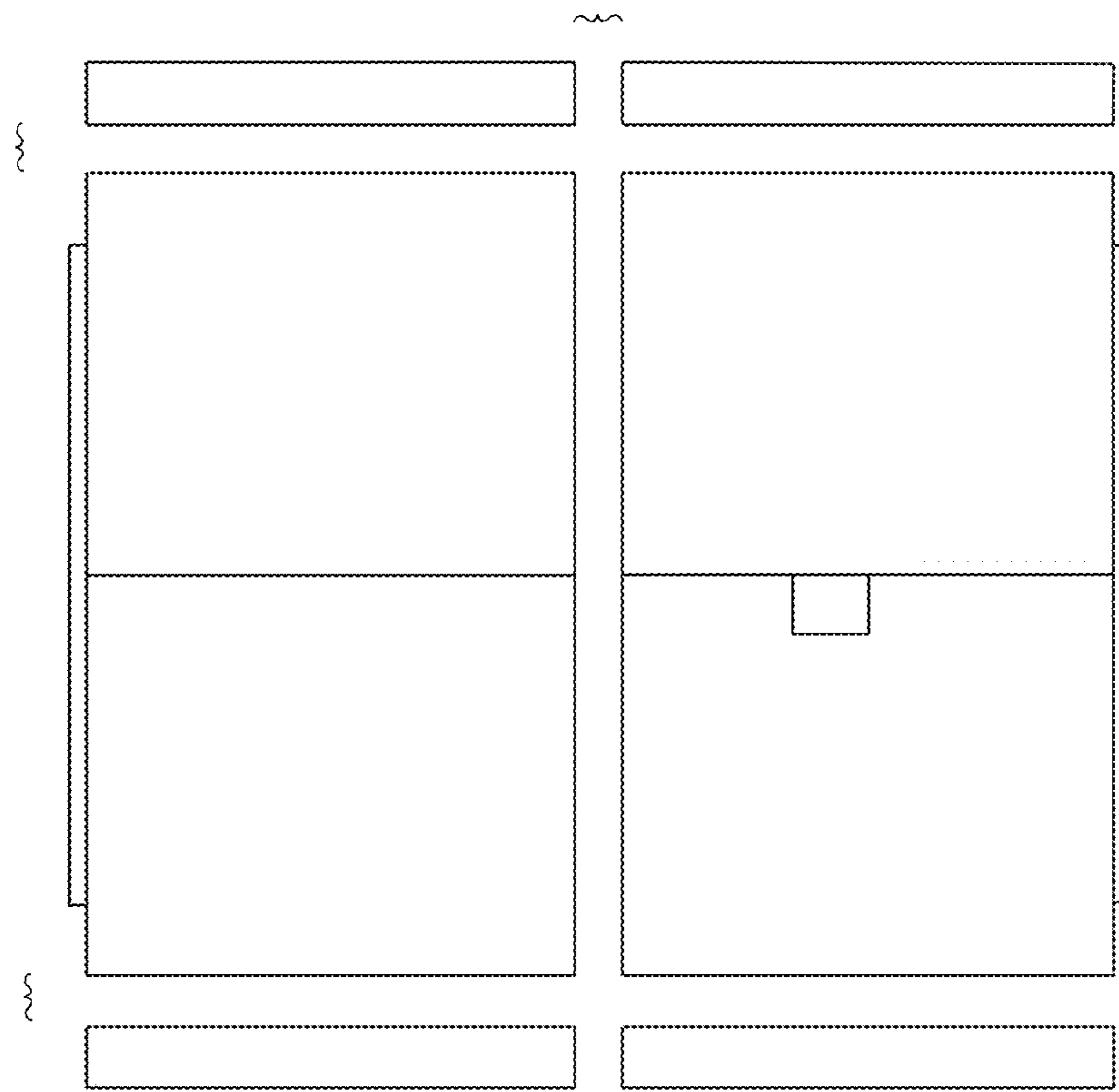

FIG. 12

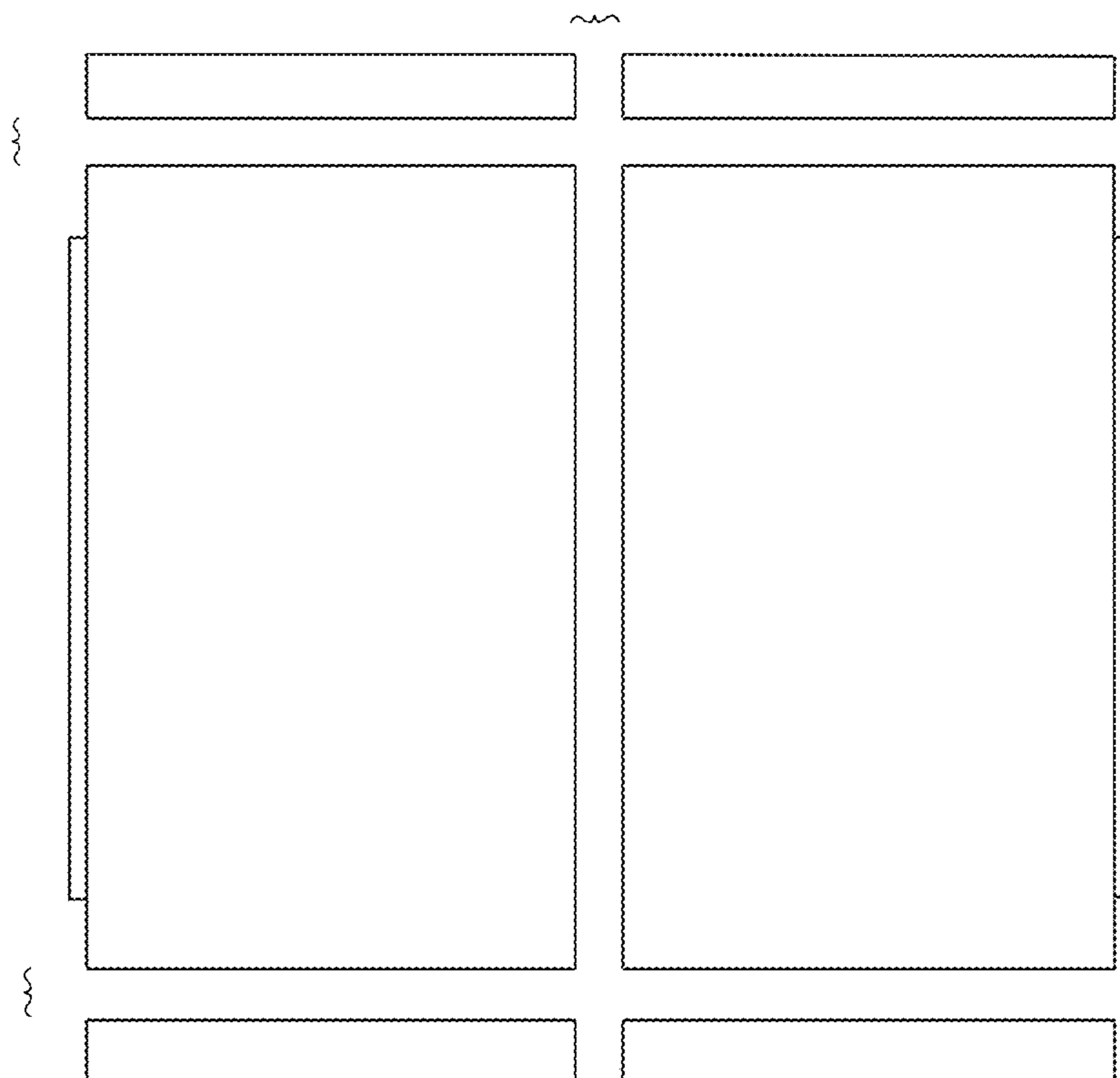

FIG. 13

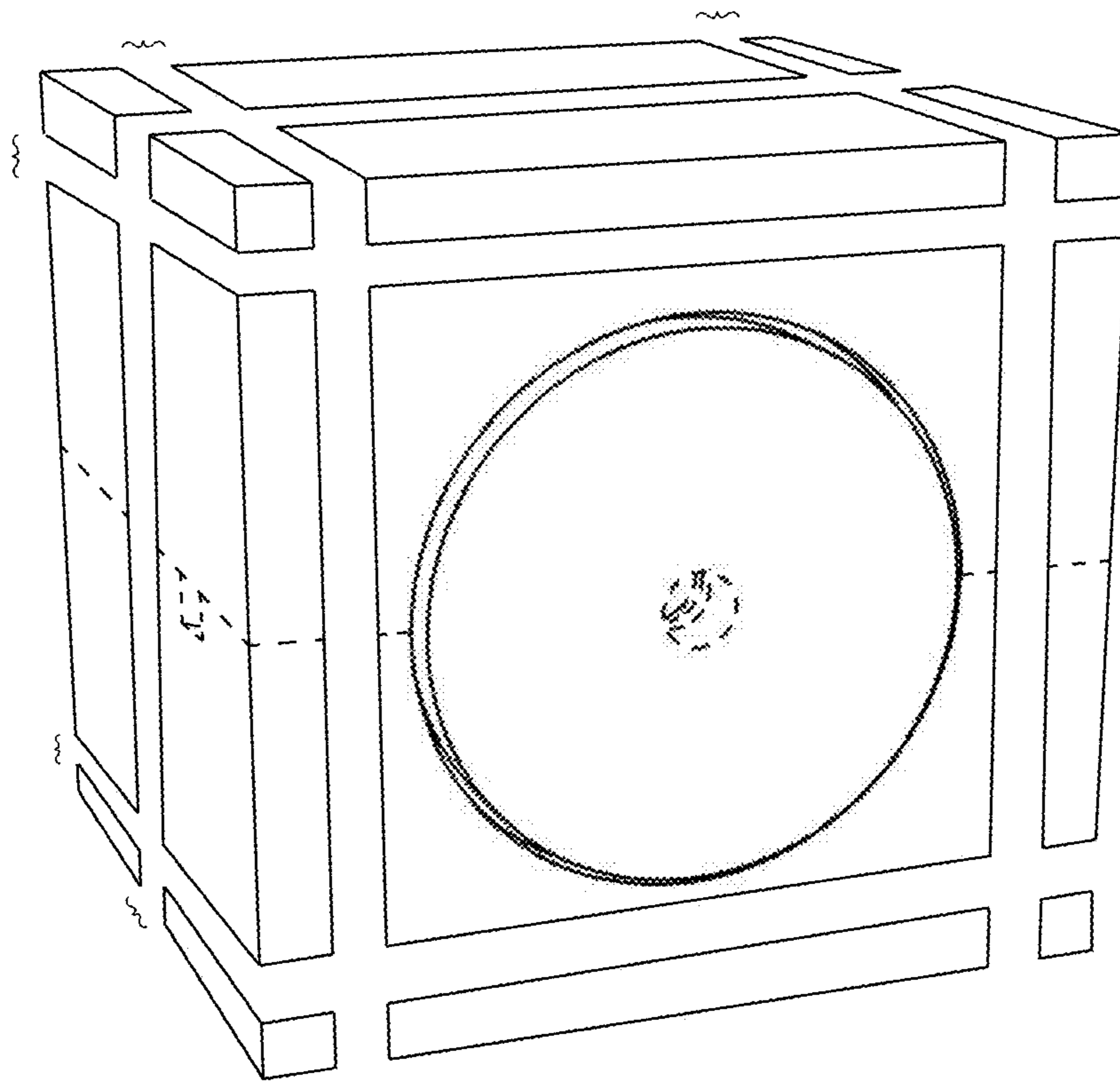

FIG. 14

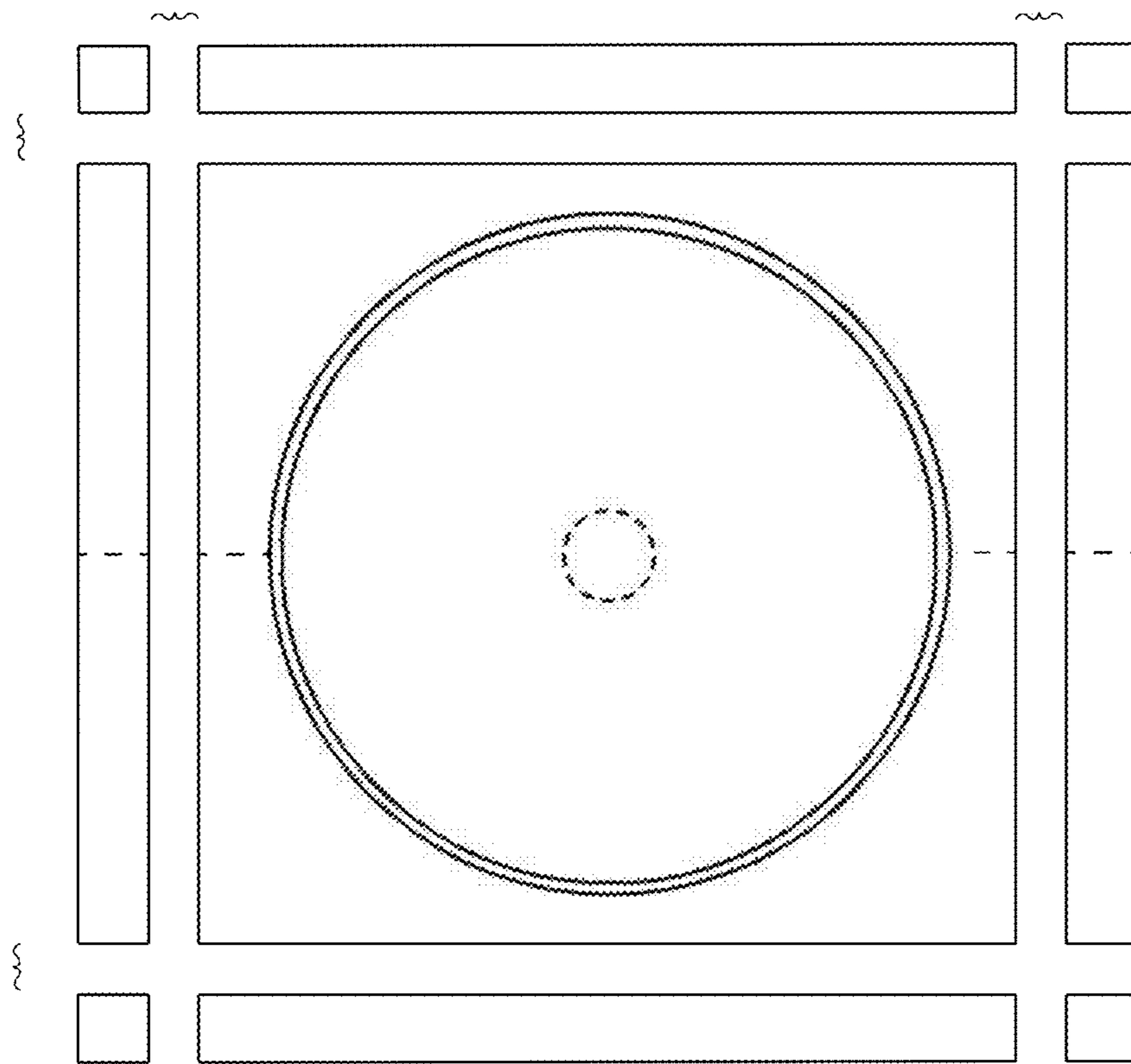

FIG. 15

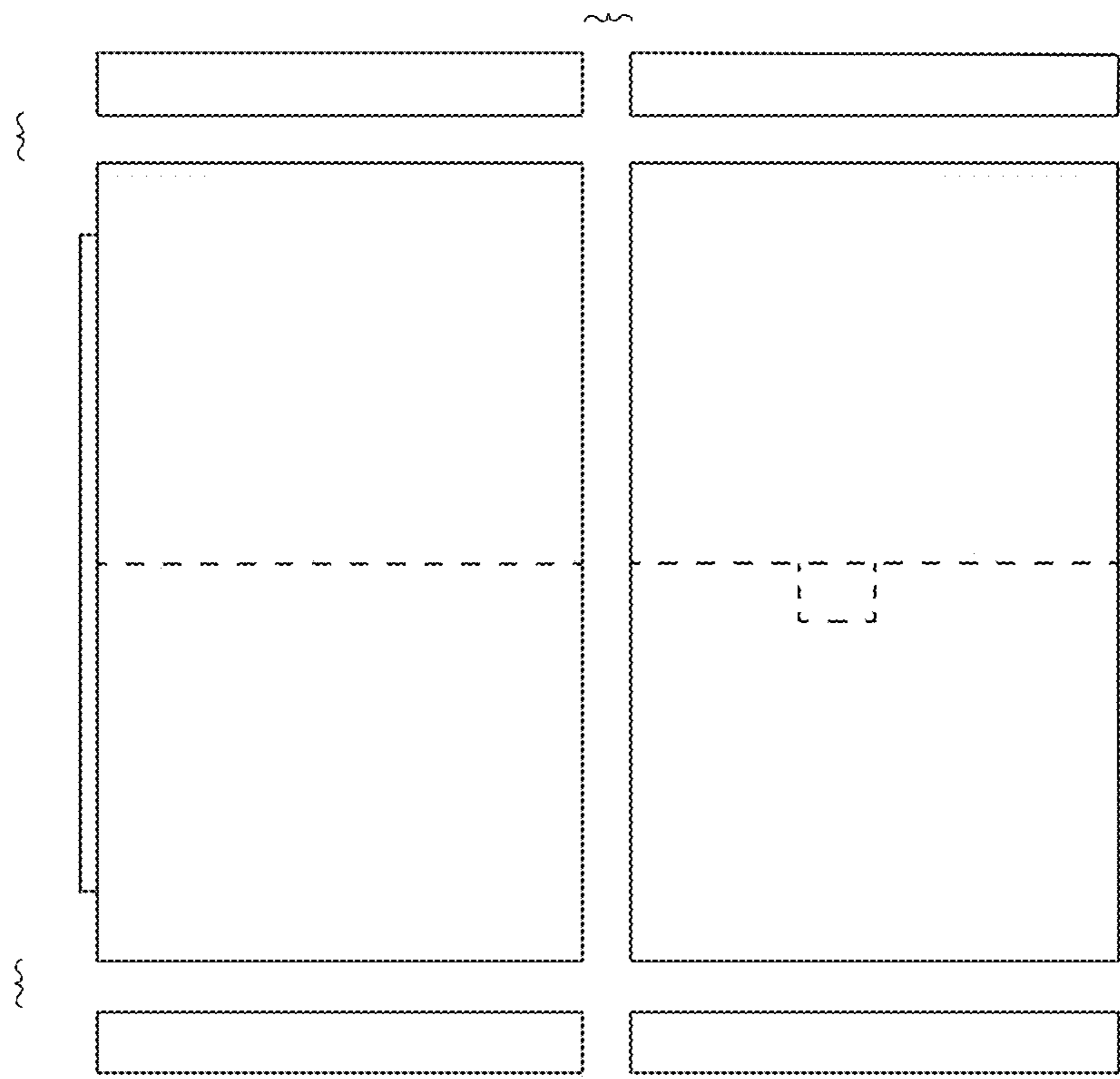

FIG. 16

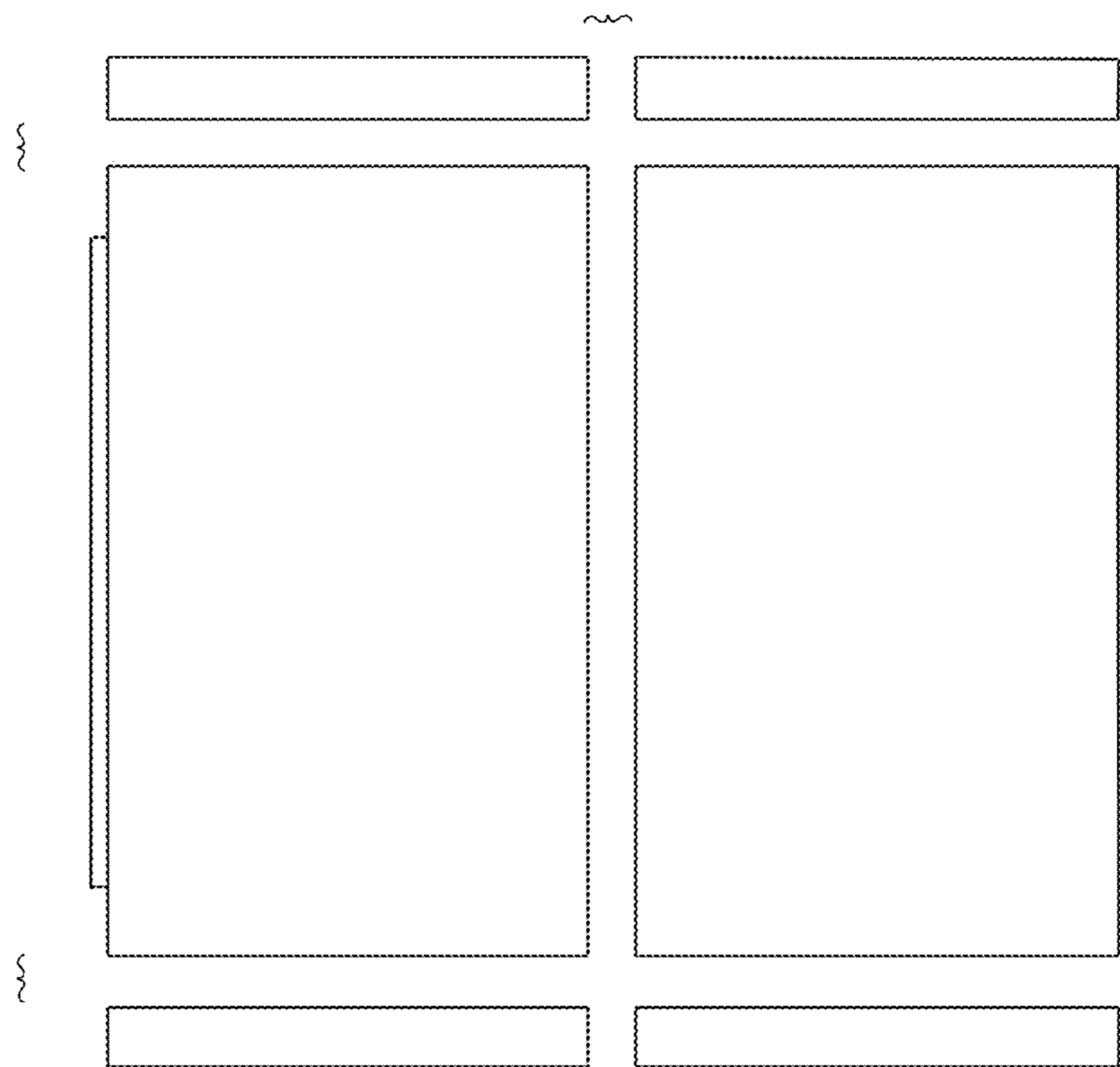

FIG. 17

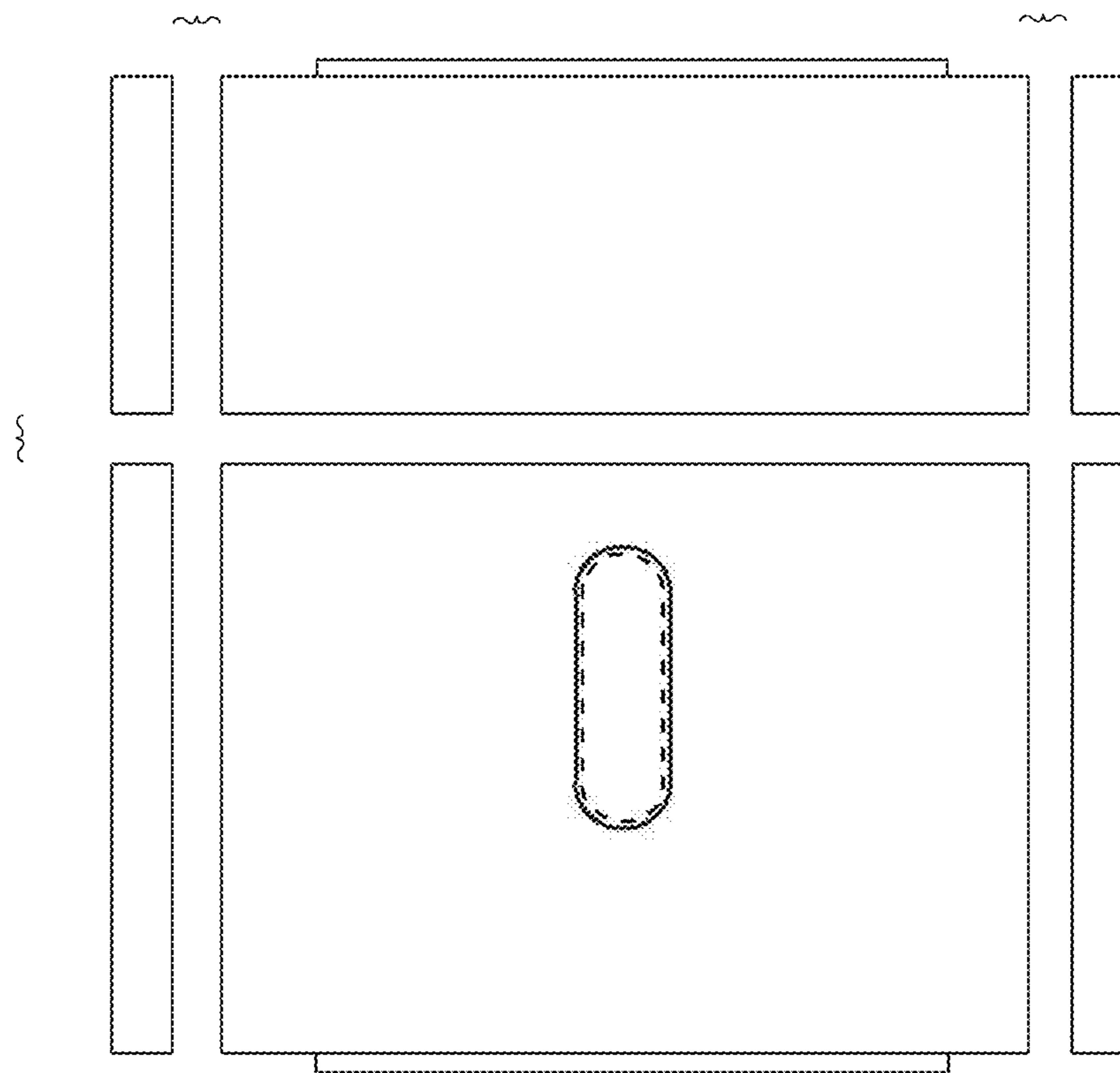

FIG. 18