



US00D914524S

(12) **United States Design Patent**
Kurisaki et al.

(10) **Patent No.:** **US D914,524 S**
(45) **Date of Patent:** **** Mar. 30, 2021**

(54) **FLOW SENSOR WITH FLOW REGULATING VALVE**

(71) Applicant: **SMC CORPORATION**, Tokyo (JP)

(72) Inventors: **Shogo Kurisaki**, Yashio (JP); **Suguru Terada**, Tsukuba (JP)

(73) Assignee: **SMC CORPORATION**, Tokyo (JP)

(**) Term: **15 Years**

(21) Appl. No.: **29/692,861**

(22) Filed: **May 29, 2019**

(30) **Foreign Application Priority Data**

Nov. 30, 2018 (CN) 201830688819.0

(51) **LOC (13) Cl.** **10-04**

(52) **U.S. Cl.**
USPC **D10/96; D23/235**

(58) **Field of Classification Search**
USPC **D10/96; D23/233, 235**
(Continued)

(56) **References Cited**

U.S. PATENT DOCUMENTS

D606,166 S 12/2009 Gunji
D609,591 S * 2/2010 Oshima D10/96
(Continued)

FOREIGN PATENT DOCUMENTS

JP D1353446 S 3/2009

Primary Examiner — Antoine Duval Davis

(74) *Attorney, Agent, or Firm* — Birch, Stewart, Kolasch & Birch, LLP

(57) **CLAIM**

The ornamental design for a flow sensor with flow regulating valve, as shown and described.

DESCRIPTION

FIG. 1 is a front, top and left side perspective view of a flow sensor with flow regulating valve showing a first embodiment of our new design;

FIG. 2 is a rear, bottom and right side perspective view thereof;

FIG. 3 is a front view thereof;

FIG. 4 is a rear view thereof;

FIG. 5 is a top plan view thereof;

FIG. 6 is a bottom plan view thereof;

FIG. 7 is a left side view thereof;

FIG. 8 is a right side view thereof;

FIG. 9 is a front, top and left side perspective view of a flow sensor with flow regulating valve showing a second embodiment of our new design;

FIG. 10 is a rear, bottom and right side perspective view of FIG. 9;

FIG. 11 is a front view of FIG. 9;

FIG. 12 is a rear view of FIG. 9;

FIG. 13 is a top plan view of FIG. 9;

FIG. 14 is a bottom plan view of FIG. 9;

FIG. 15 is a left side view of FIG. 9;

FIG. 16 is a right side view of FIG. 9;

FIG. 17 is a front, top and left side perspective view of a flow sensor with flow regulating valve showing a third embodiment of our new design;

FIG. 18 is a rear, bottom and right side perspective view of FIG. 17;

FIG. 19 is a front view of FIG. 17;

FIG. 20 is a rear view of FIG. 17;

FIG. 21 is a top plan view of FIG. 17;

FIG. 22 is a bottom plan view of FIG. 17;

FIG. 23 is a left side view of FIG. 17;

FIG. 24 is a right side view of FIG. 17;

FIG. 25 is a front, top and left side perspective view of a flow sensor with flow regulating valve showing a fourth embodiment of our new design;

FIG. 26 is a rear, bottom and right side perspective view of FIG. 25;

FIG. 27 is a front view of FIG. 25;

FIG. 28 is a rear view of FIG. 25;

FIG. 29 is a top plan view of FIG. 25;

FIG. 30 is a bottom plan view of FIG. 25;

(Continued)

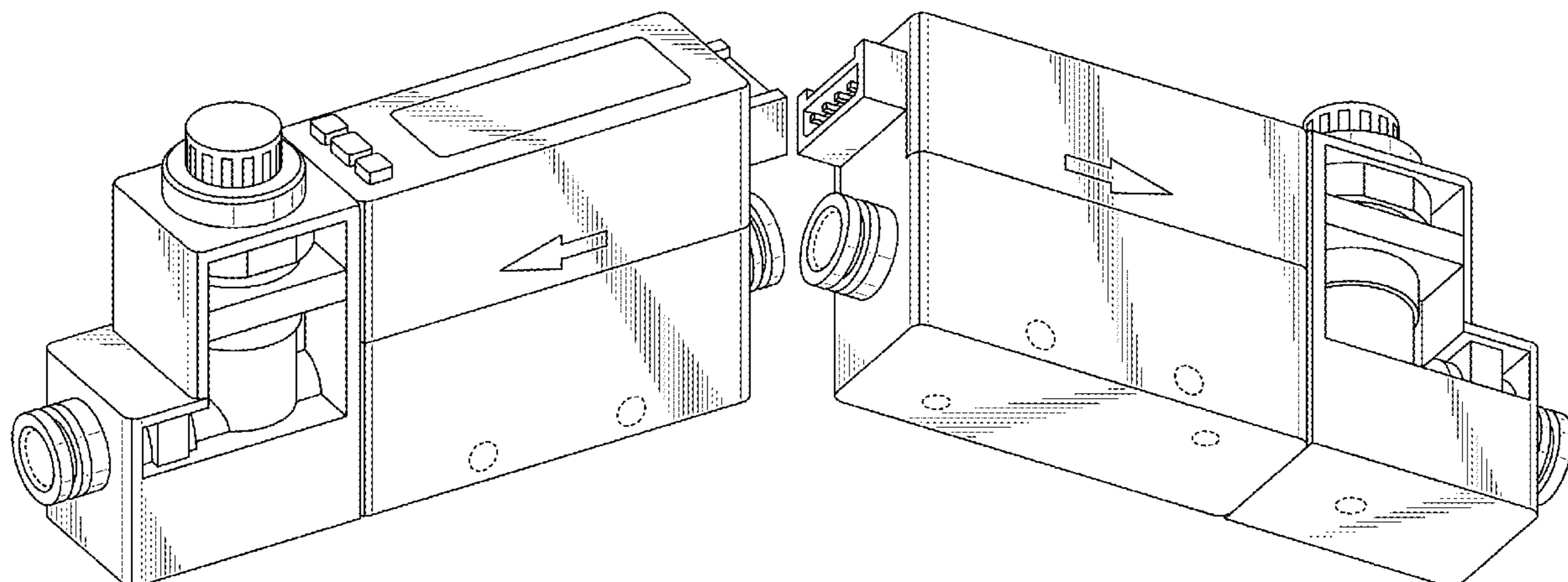

FIG. 31 is a left side view of FIG. 25;
FIG. 32 is a right side view of FIG. 25;
FIG. 33 is a front, top and left side perspective view of a flow sensor with flow regulating valve showing a fifth embodiment of our new design;
FIG. 34 is a rear, bottom and right side perspective view of FIG. 33;
FIG. 35 is a front view of FIG. 33;
FIG. 36 is a rear view of FIG. 33;
FIG. 37 is a top plan view of FIG. 33;
FIG. 38 is a bottom plan view of FIG. 33;
FIG. 39 is a left side view of FIG. 33; and,
FIG. 40 is a right side view of FIG. 33.
The broken lines depict portions of the flow sensor with flow regulating valve that form no part of the claimed design.

1 Claim, 40 Drawing Sheets

(58) **Field of Classification Search**
CPC G01F 1/40; G01F 1/42; G01F 1/44; G01F 1/46; G01F 1/74; G01F 11/003; G01F 11/006; G01F 15/12; G01F 15/18; G01F 15/00; G01F 3/00; G01F 3/02; G01F 3/04; G01F 3/06; G01F 3/065; G01F 3/08; G01F 3/10; G01F 3/12; F15D 1/001; G01N 21/03; G01N 21/05; G01N 2021/0378; G01N 2021/0382; G01N 2021/052; G01N 2021/054; G01N 2021/056; G01N 2021/058
See application file for complete search history.

(56) **References Cited**
U.S. PATENT DOCUMENTS
D681,489 S * 5/2013 Williamson D10/99
D828,498 S * 9/2018 Doi D23/233
D828,499 S * 9/2018 Doi D23/233
D850,583 S * 6/2019 Uehara D23/233

* cited by examiner

FIG. 1

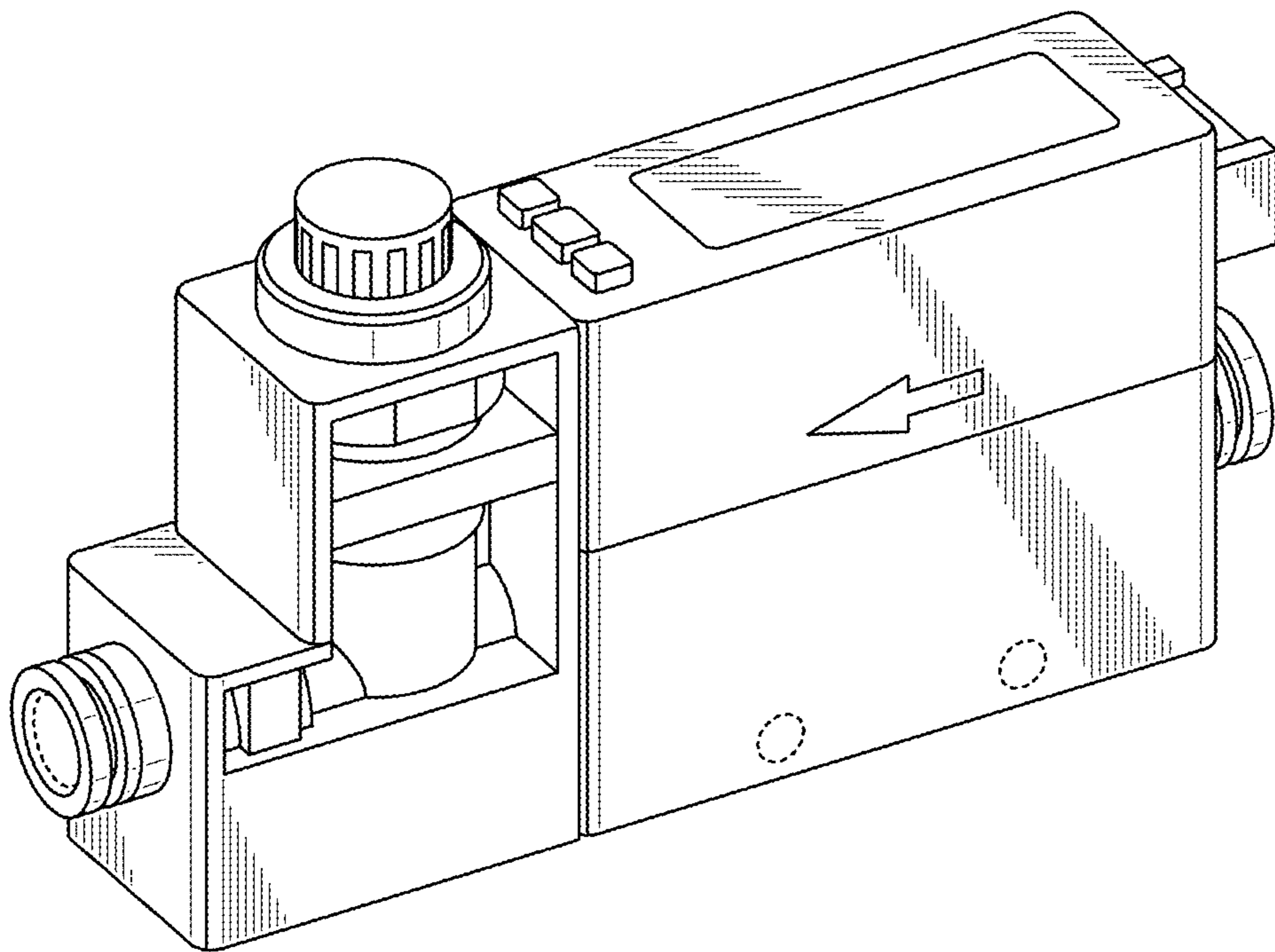

FIG. 2

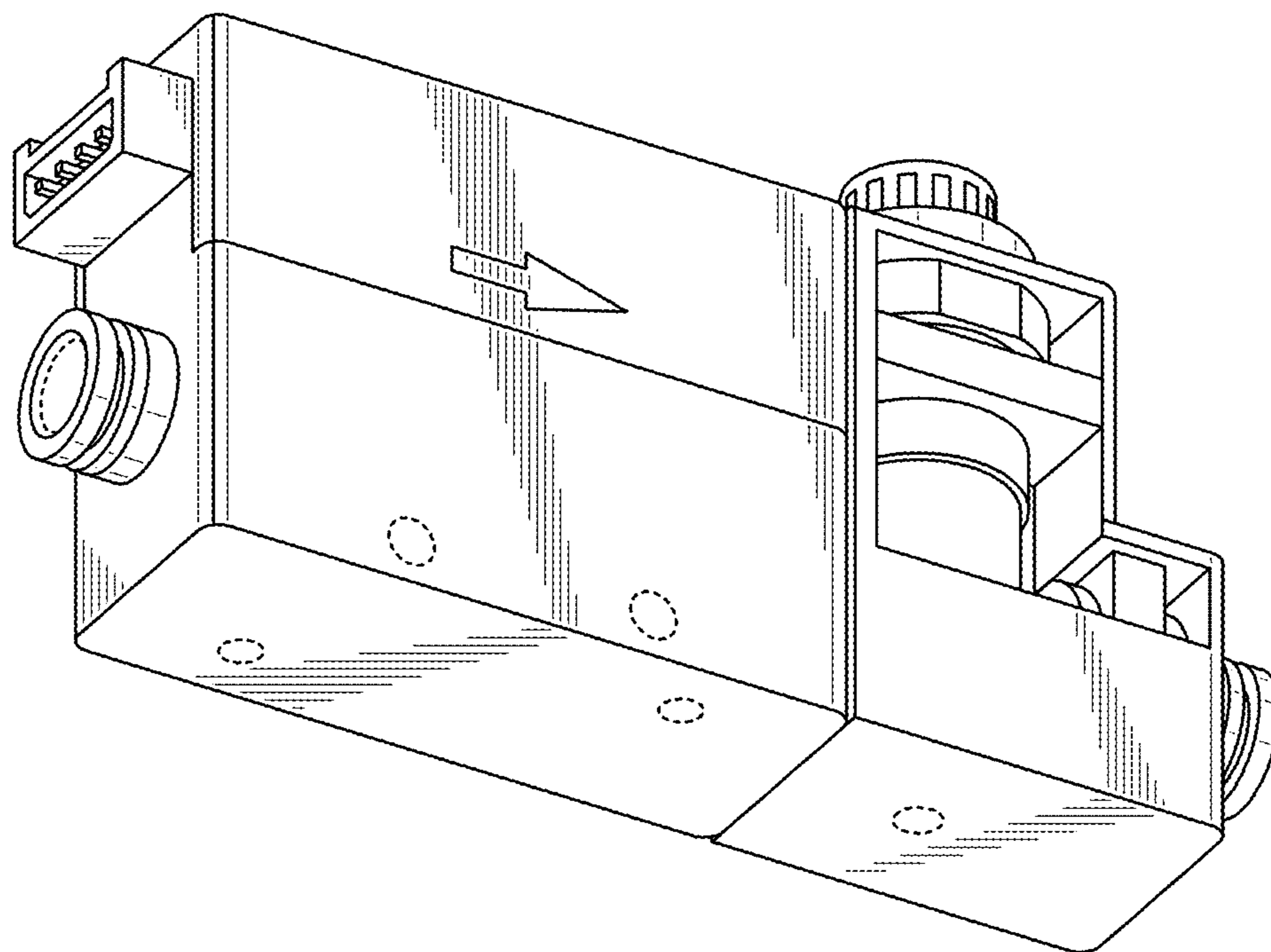

FIG. 3

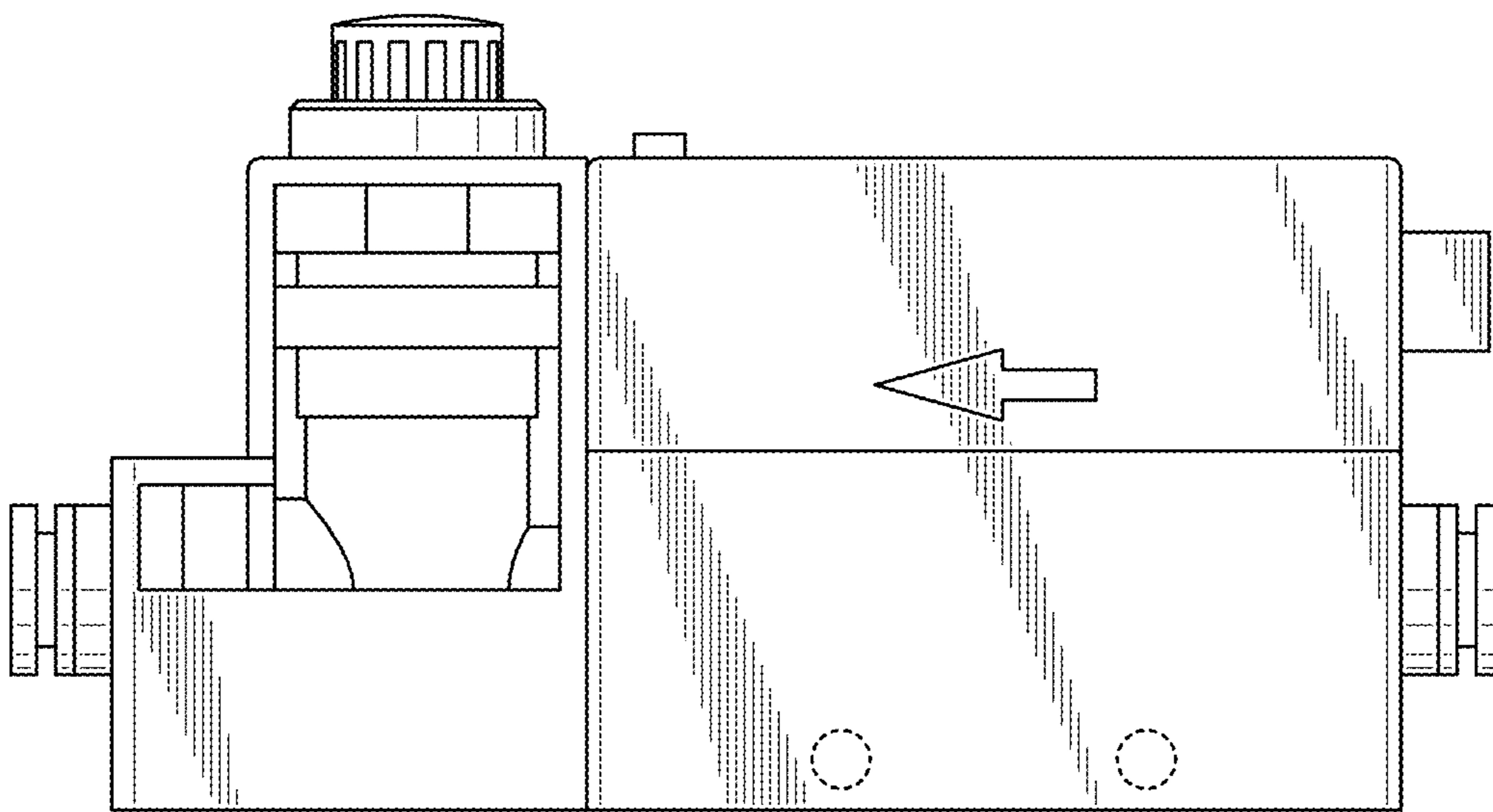

FIG. 4

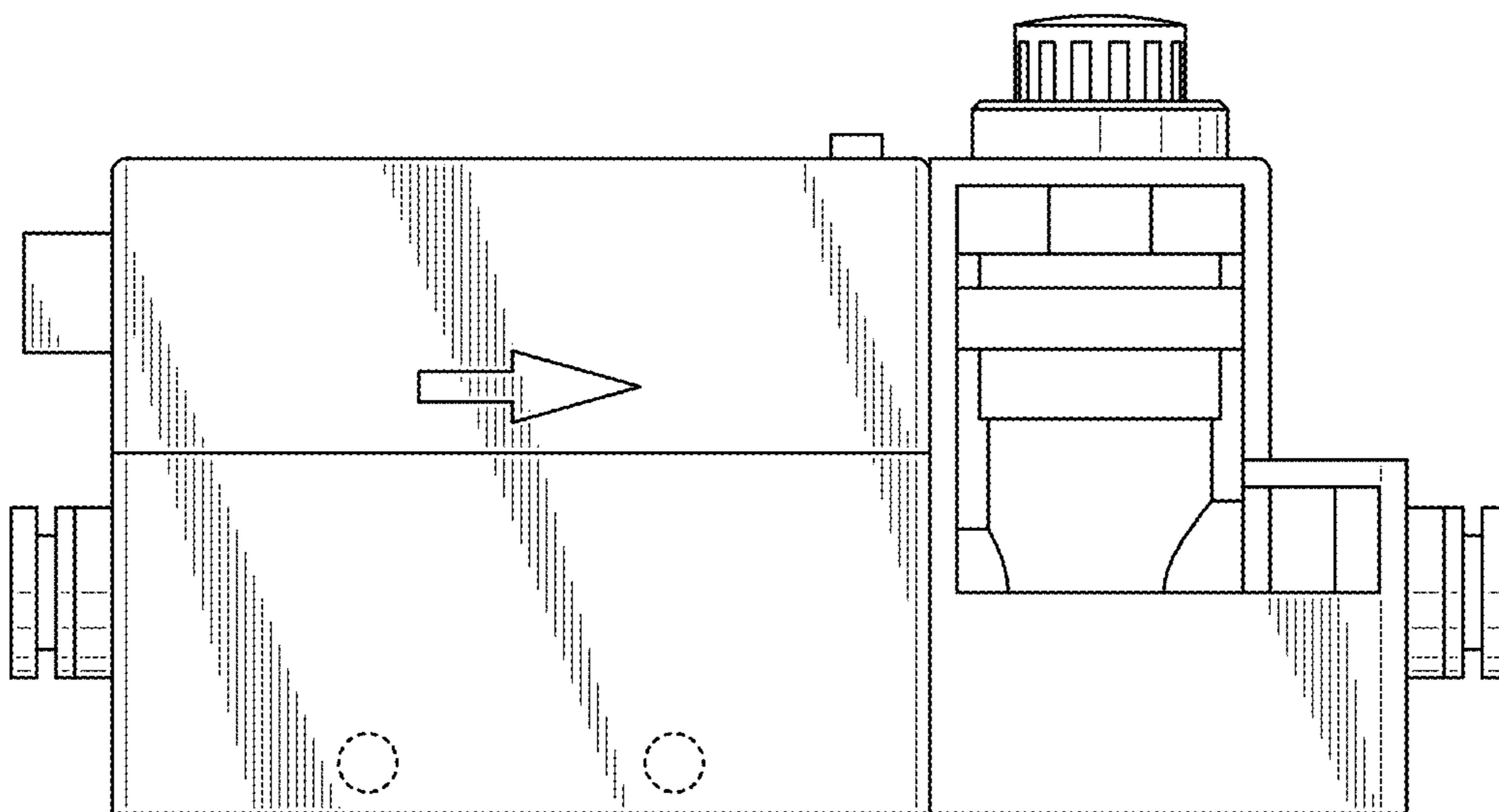

FIG. 5

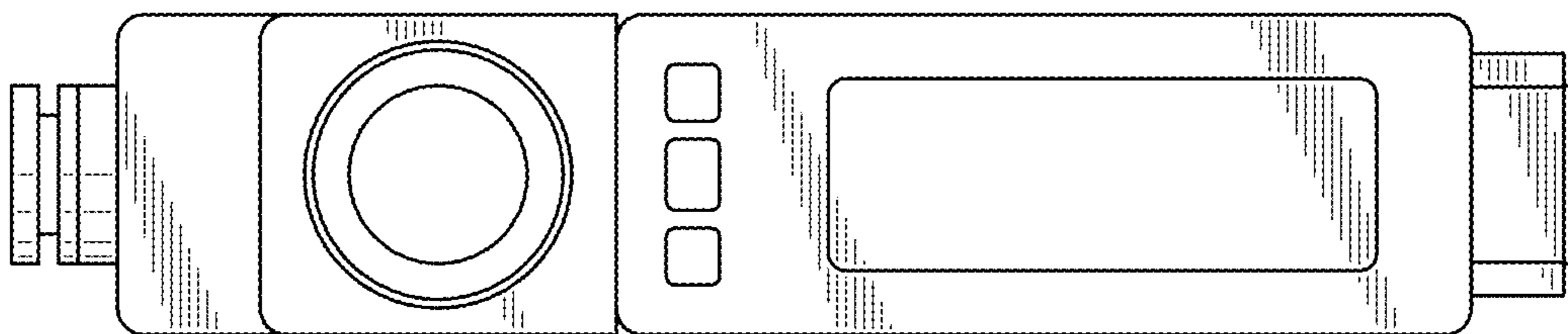

FIG. 6

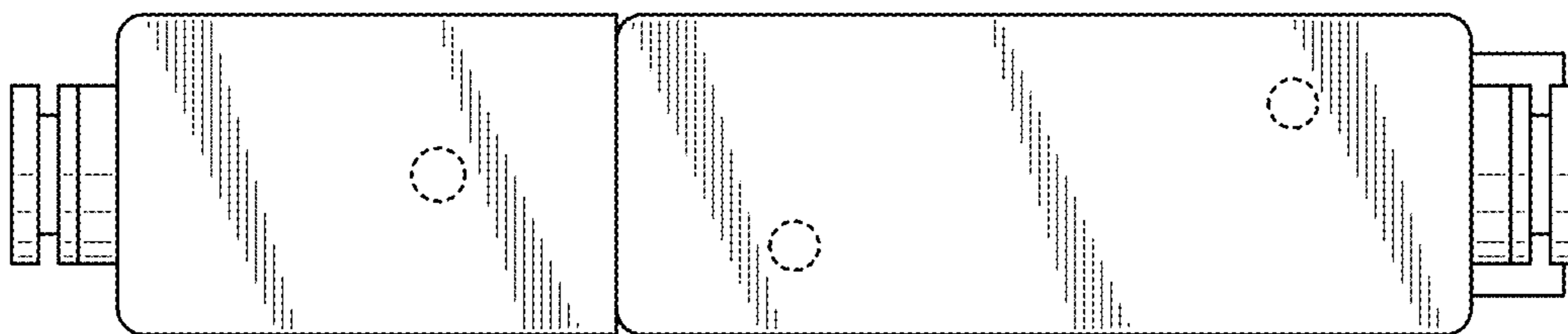

FIG. 7

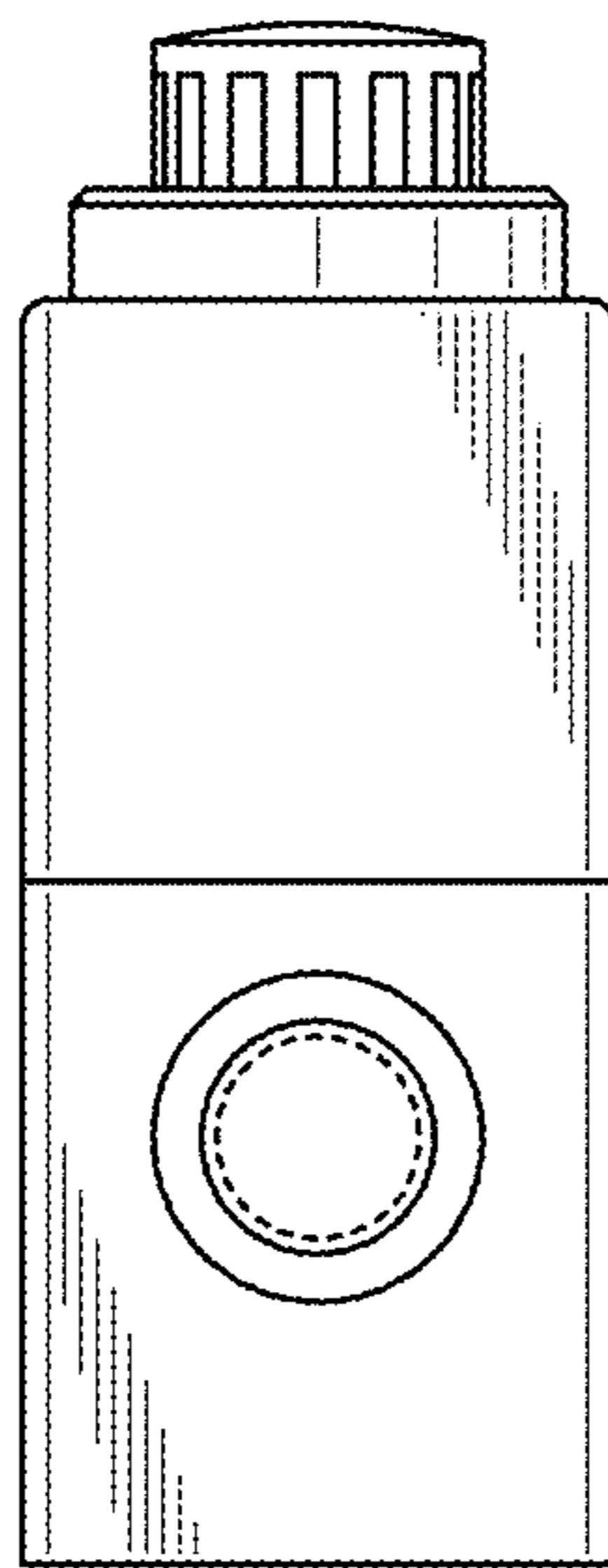

FIG. 8

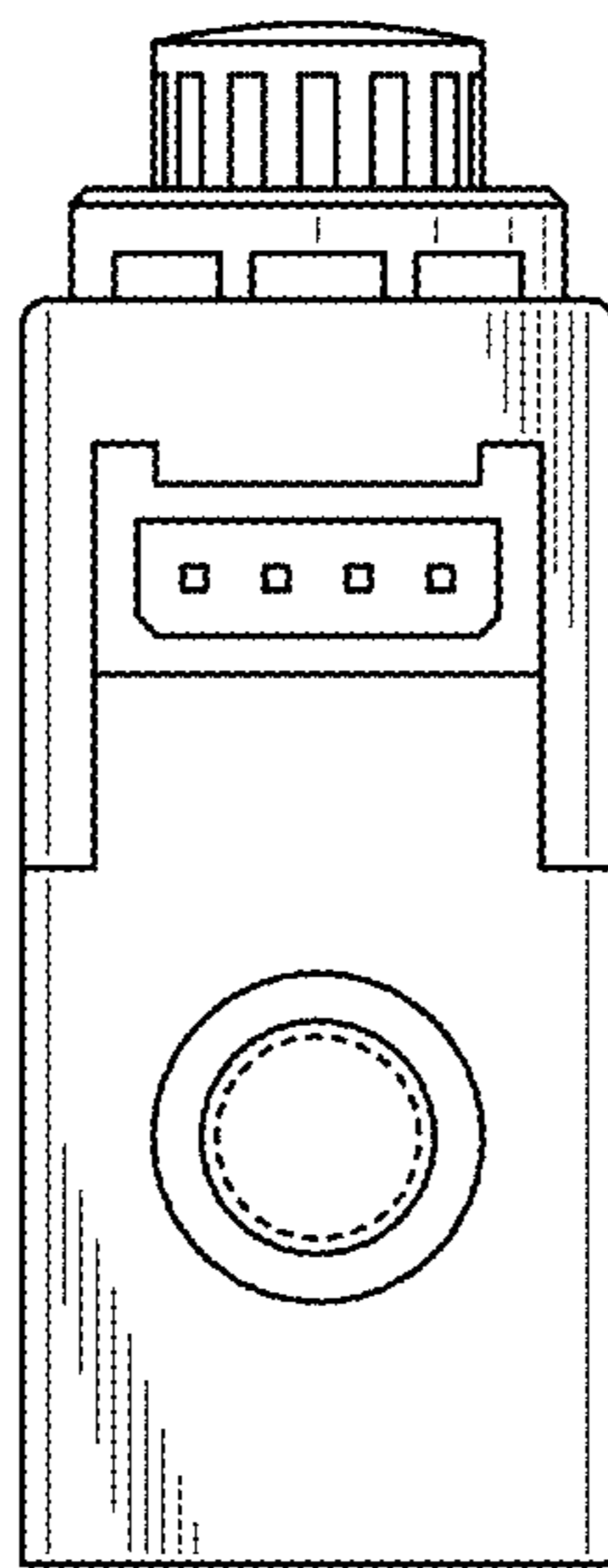

FIG. 9

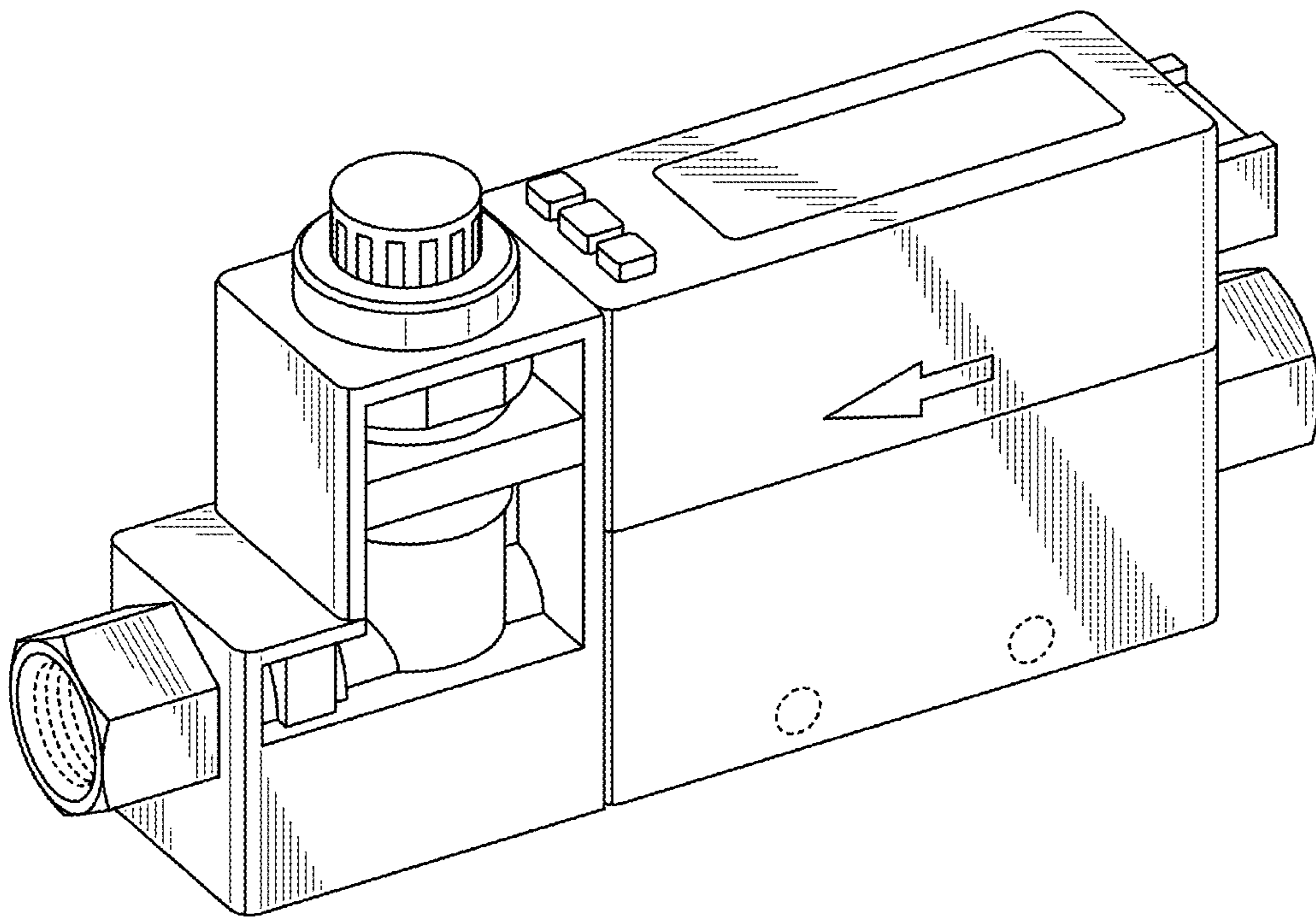

FIG. 10

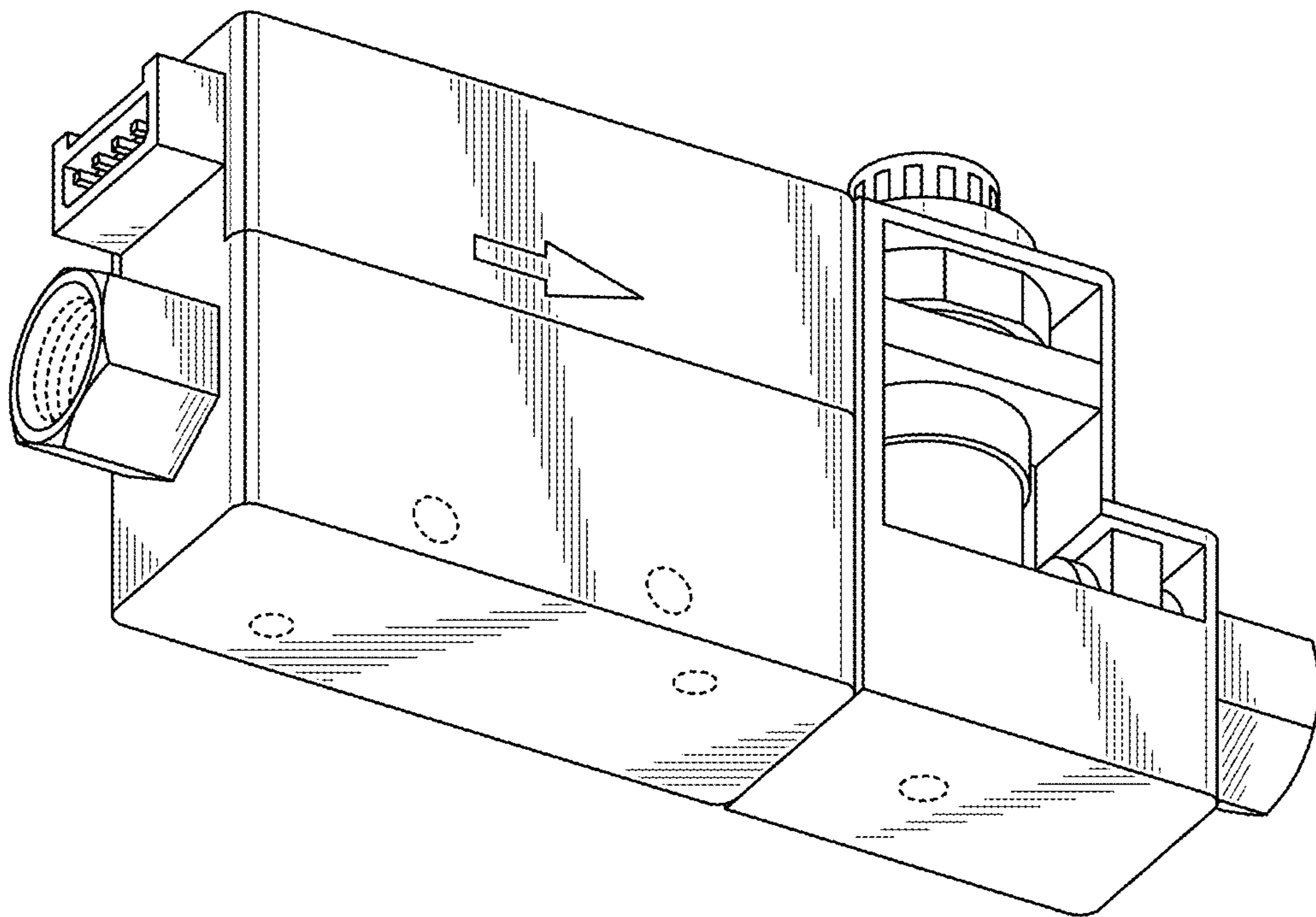

FIG. 11

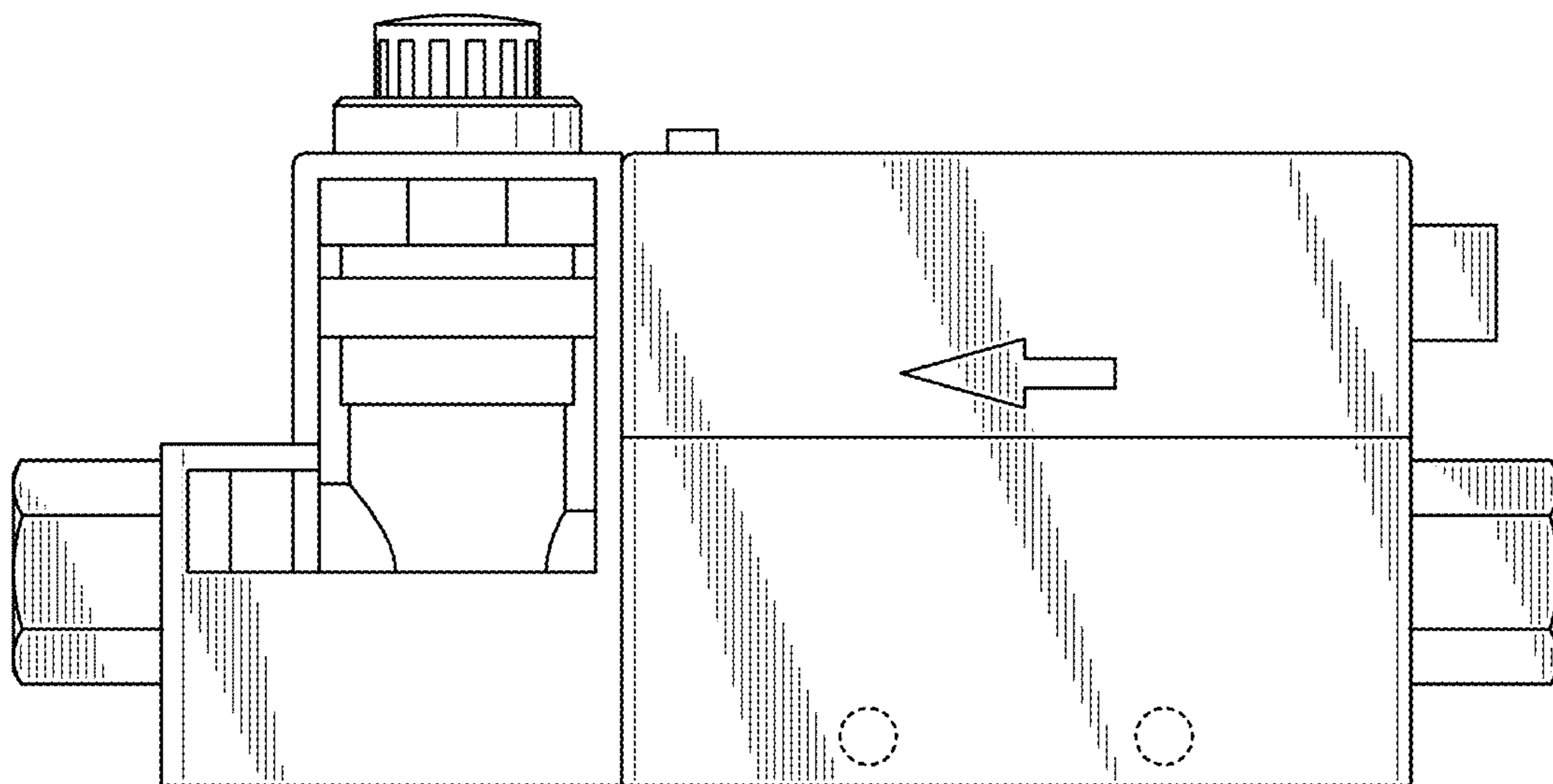

FIG. 12

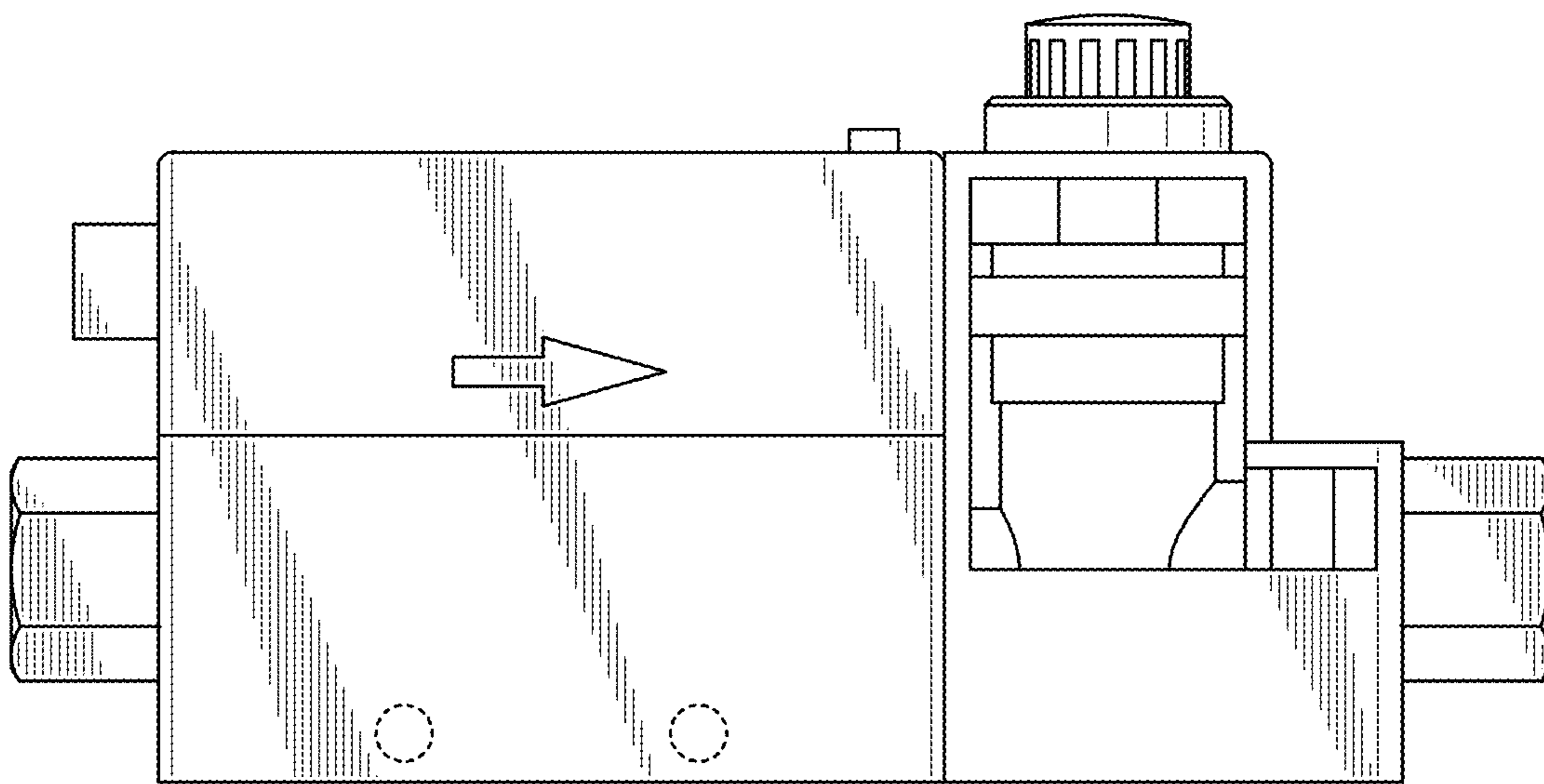

FIG. 13

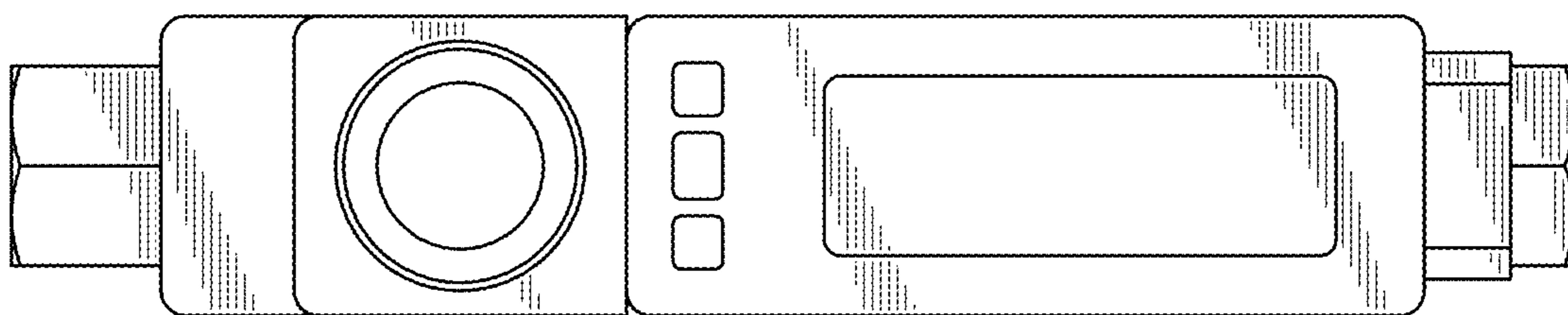

FIG. 14

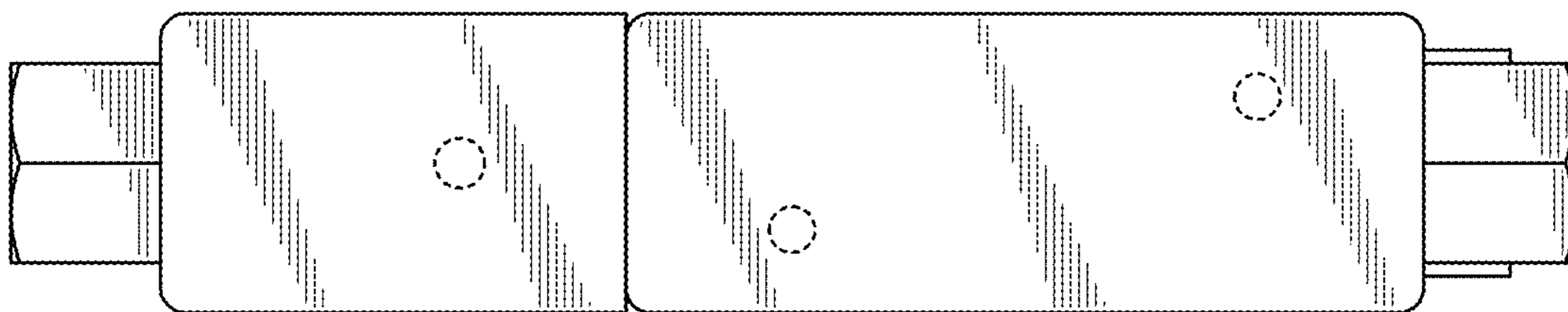

FIG. 15

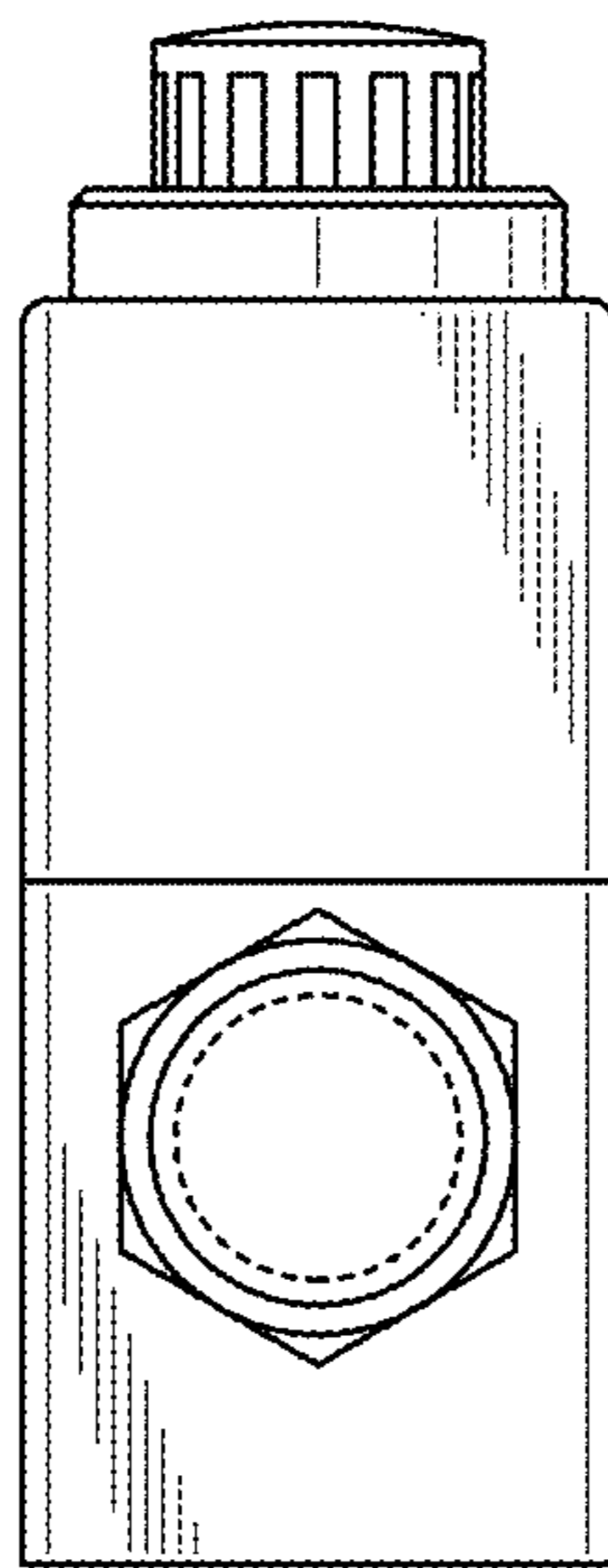

FIG. 16

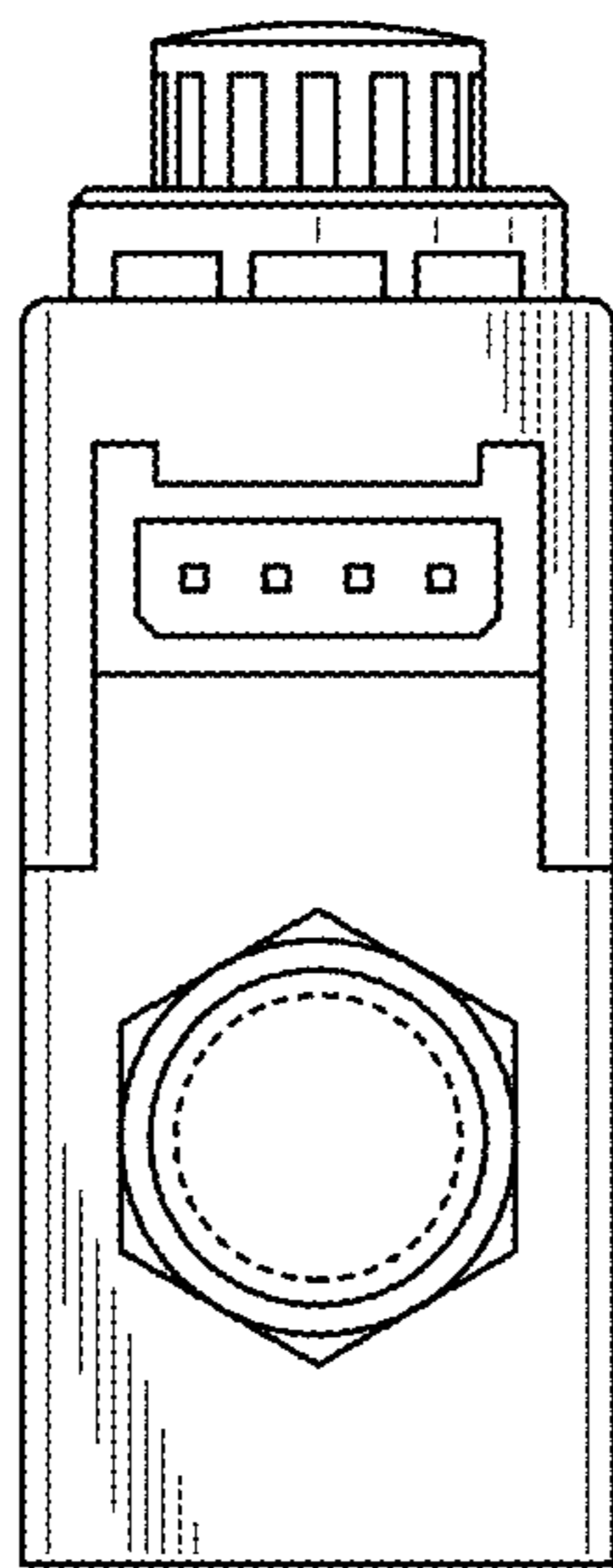

FIG. 17

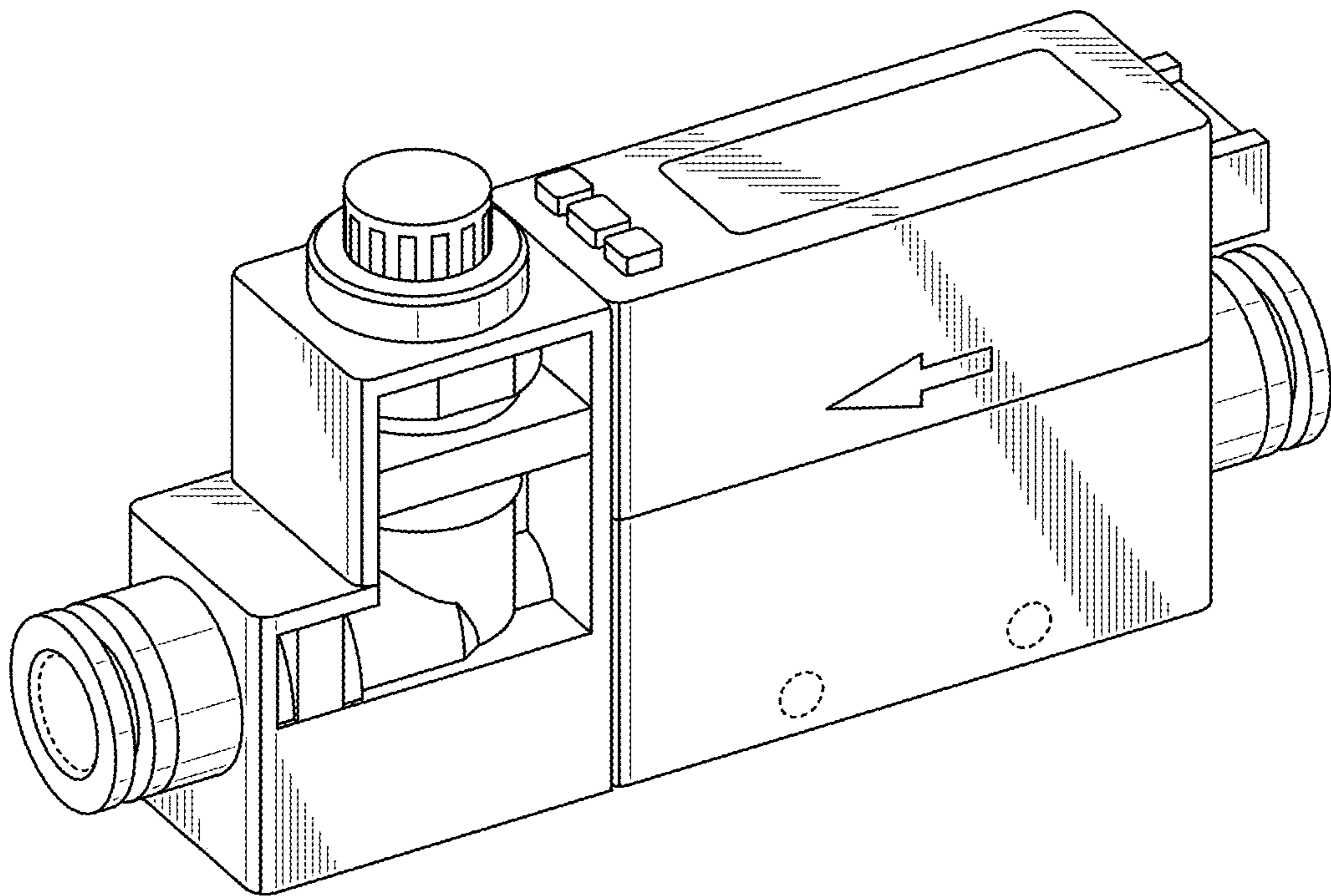

FIG. 18

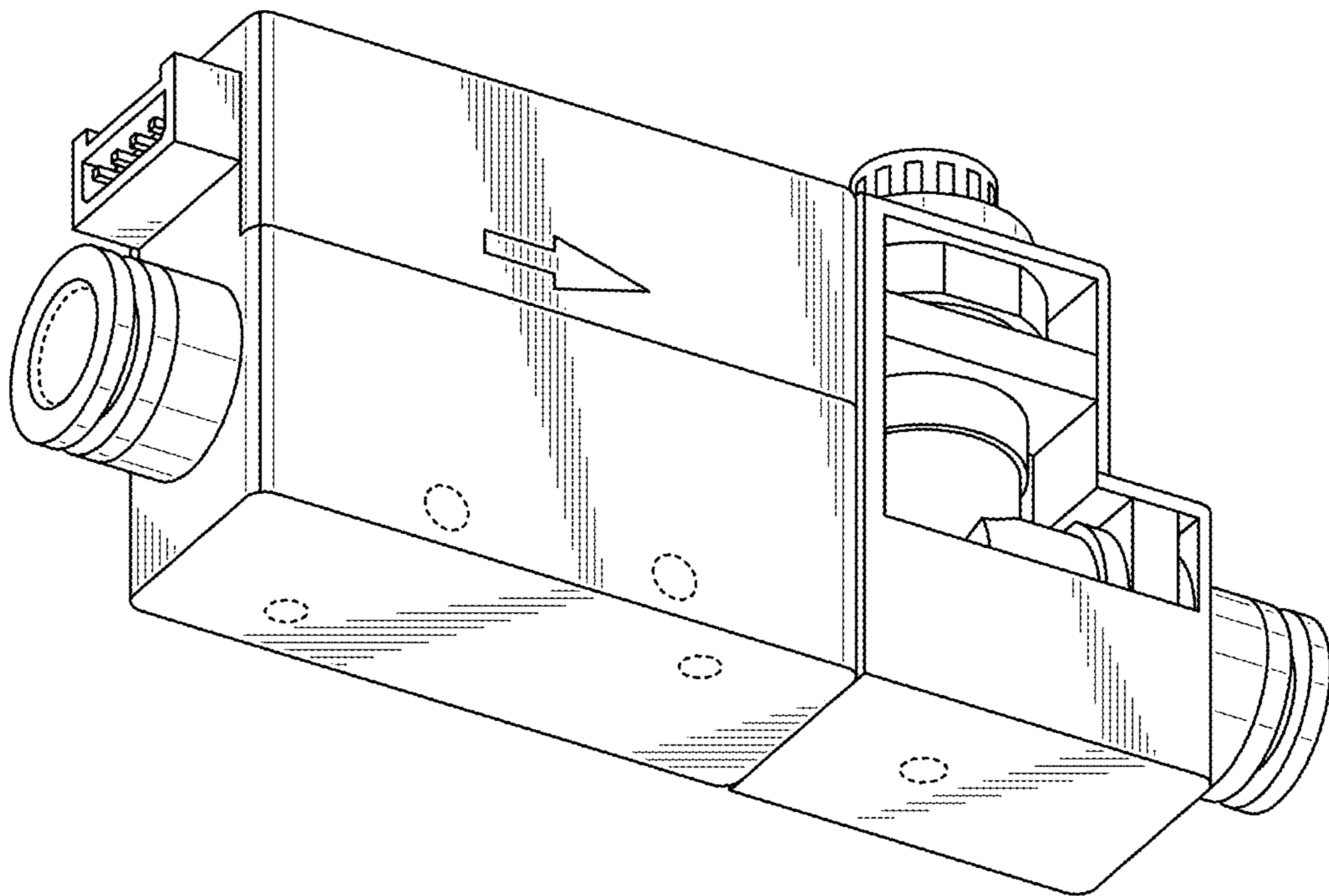

FIG. 19

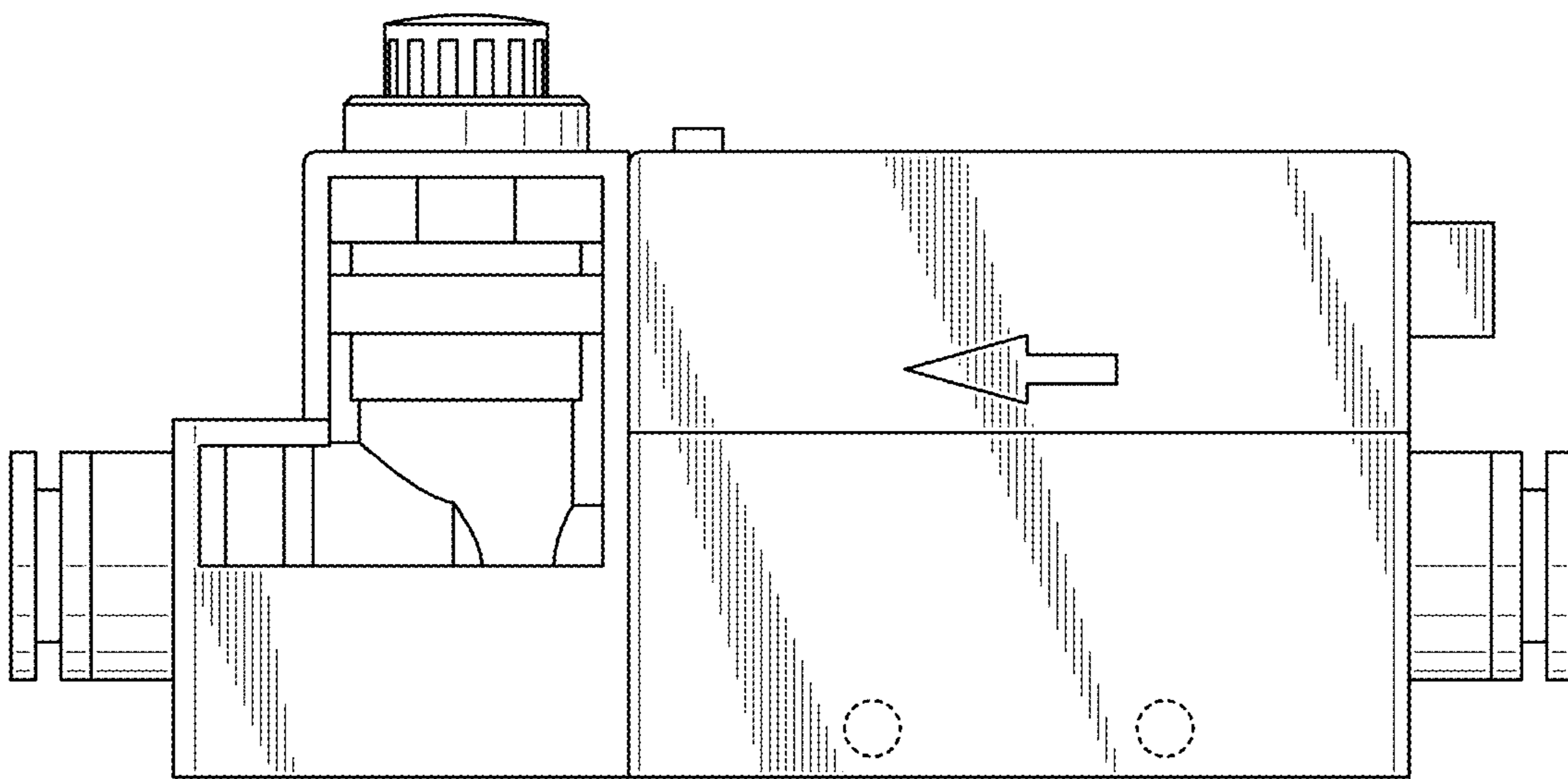

FIG. 20

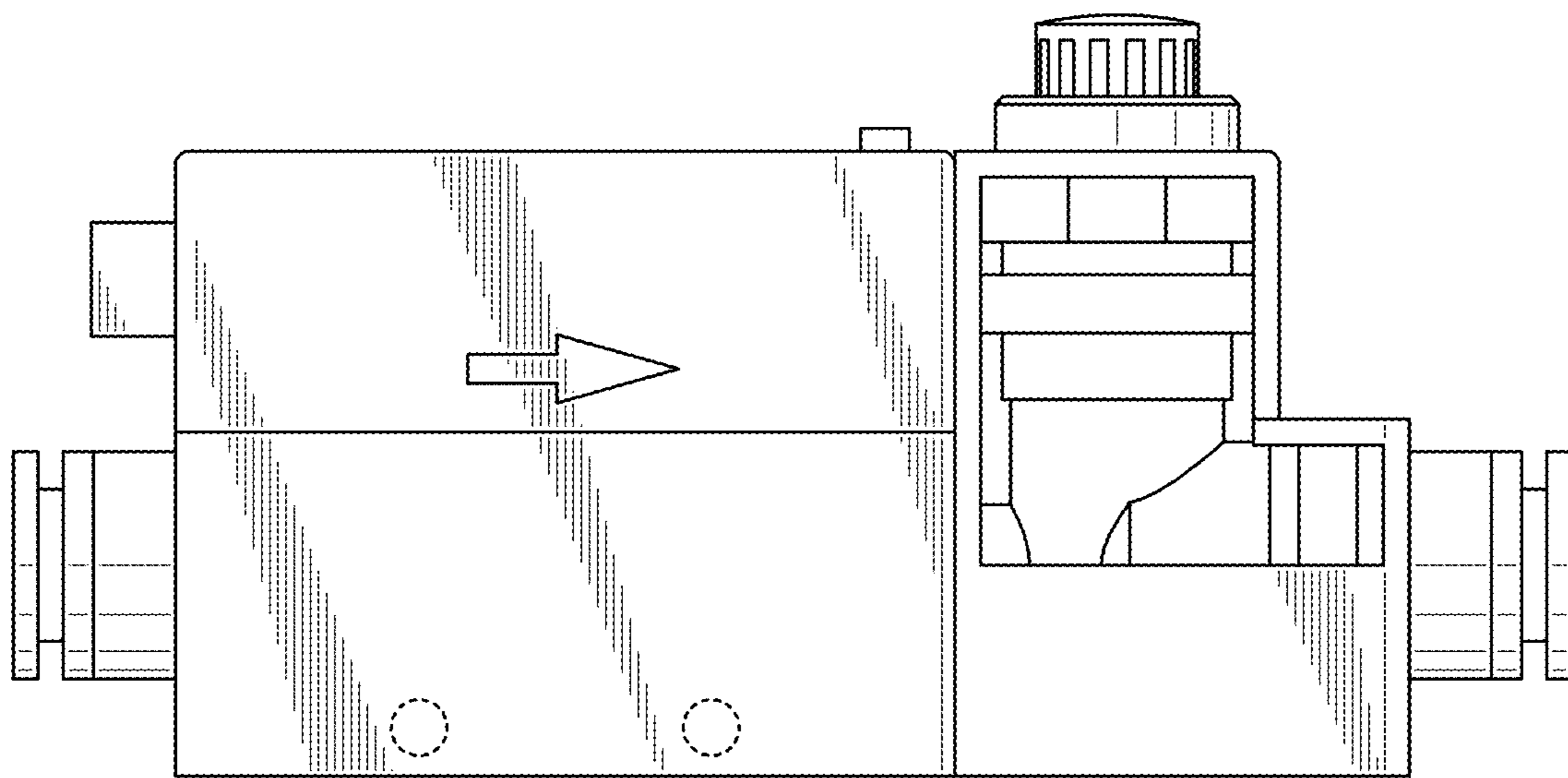

FIG. 21

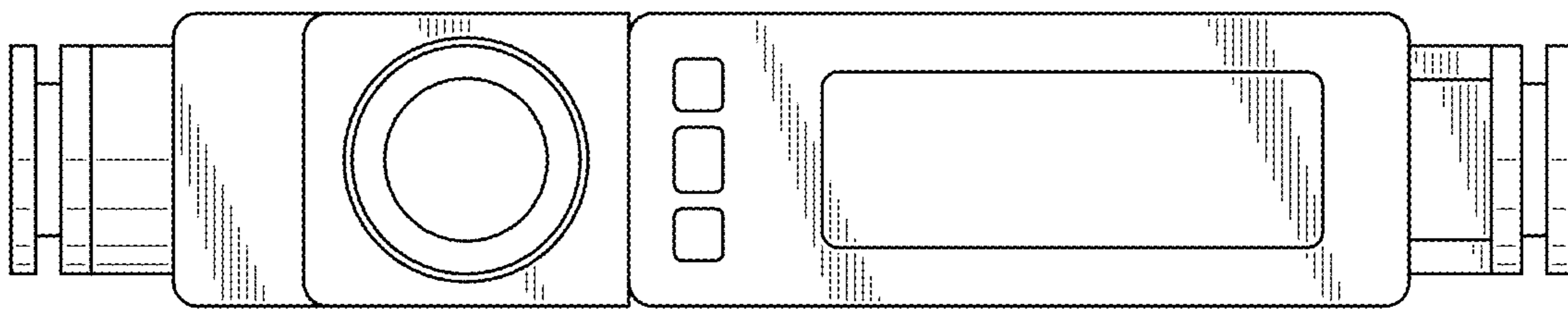

FIG. 22

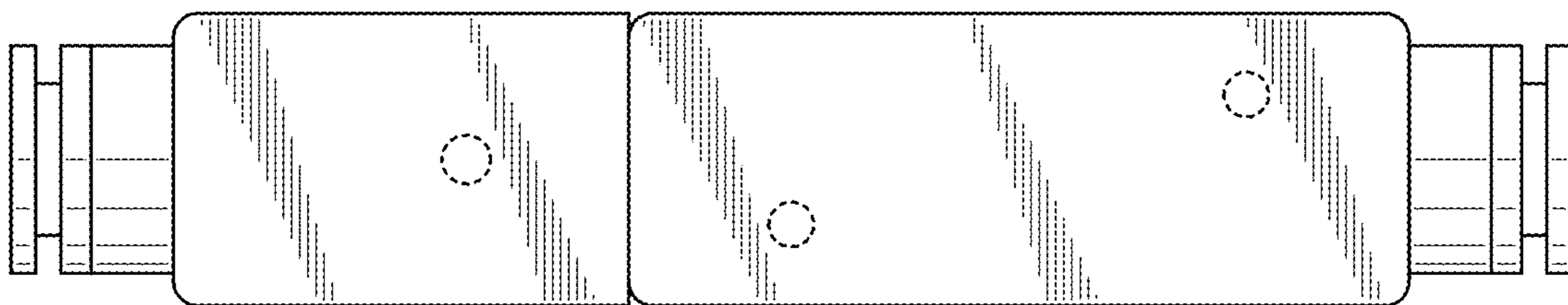

FIG. 23

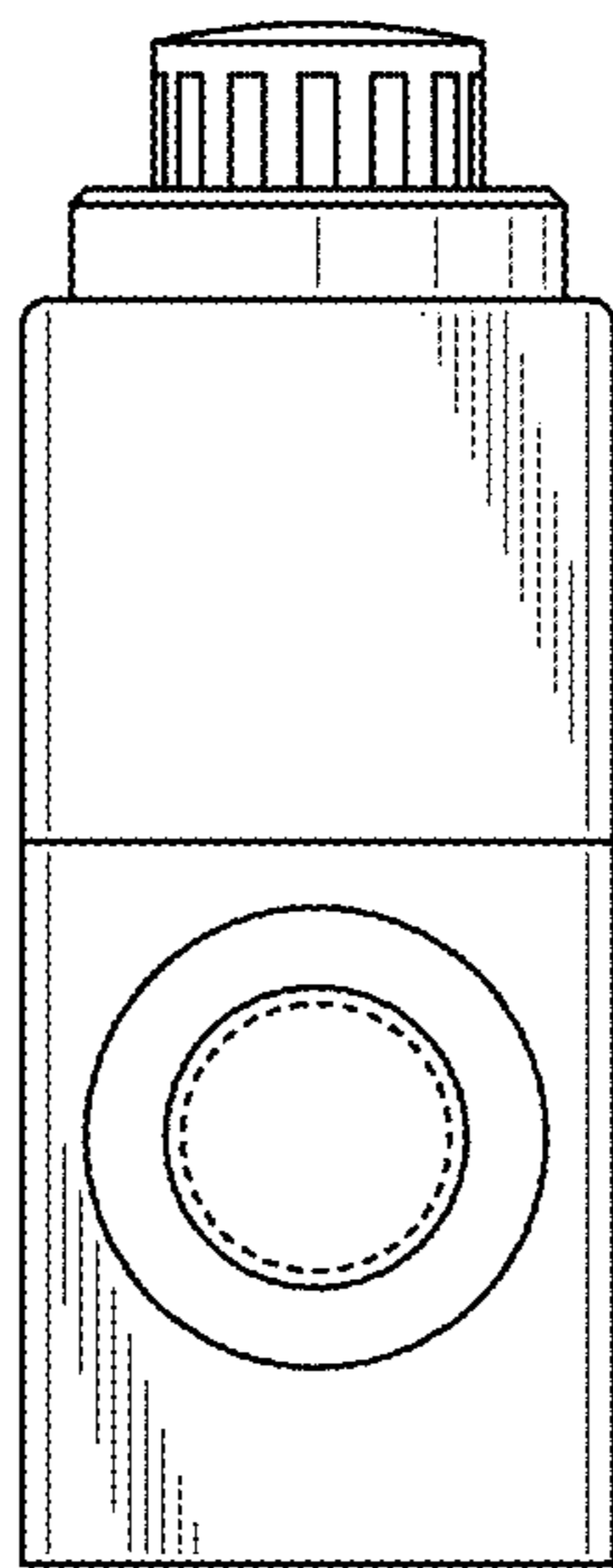

FIG. 24

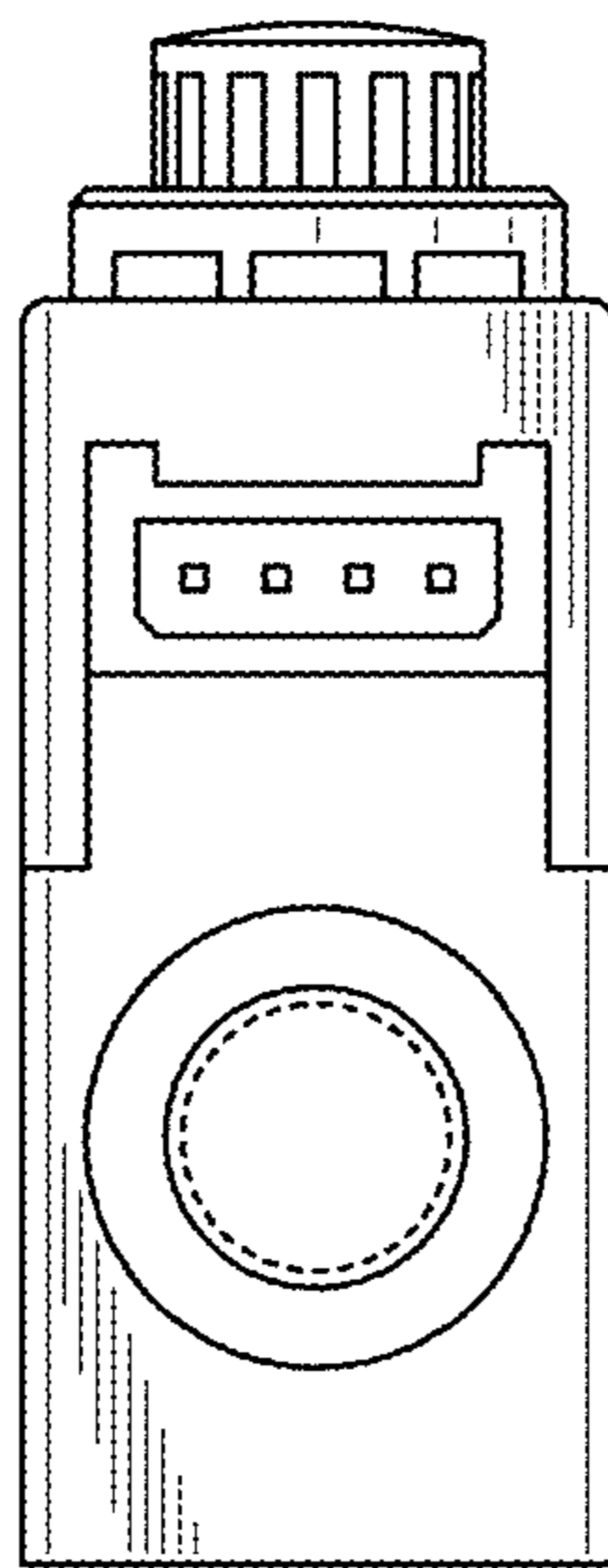

FIG. 25

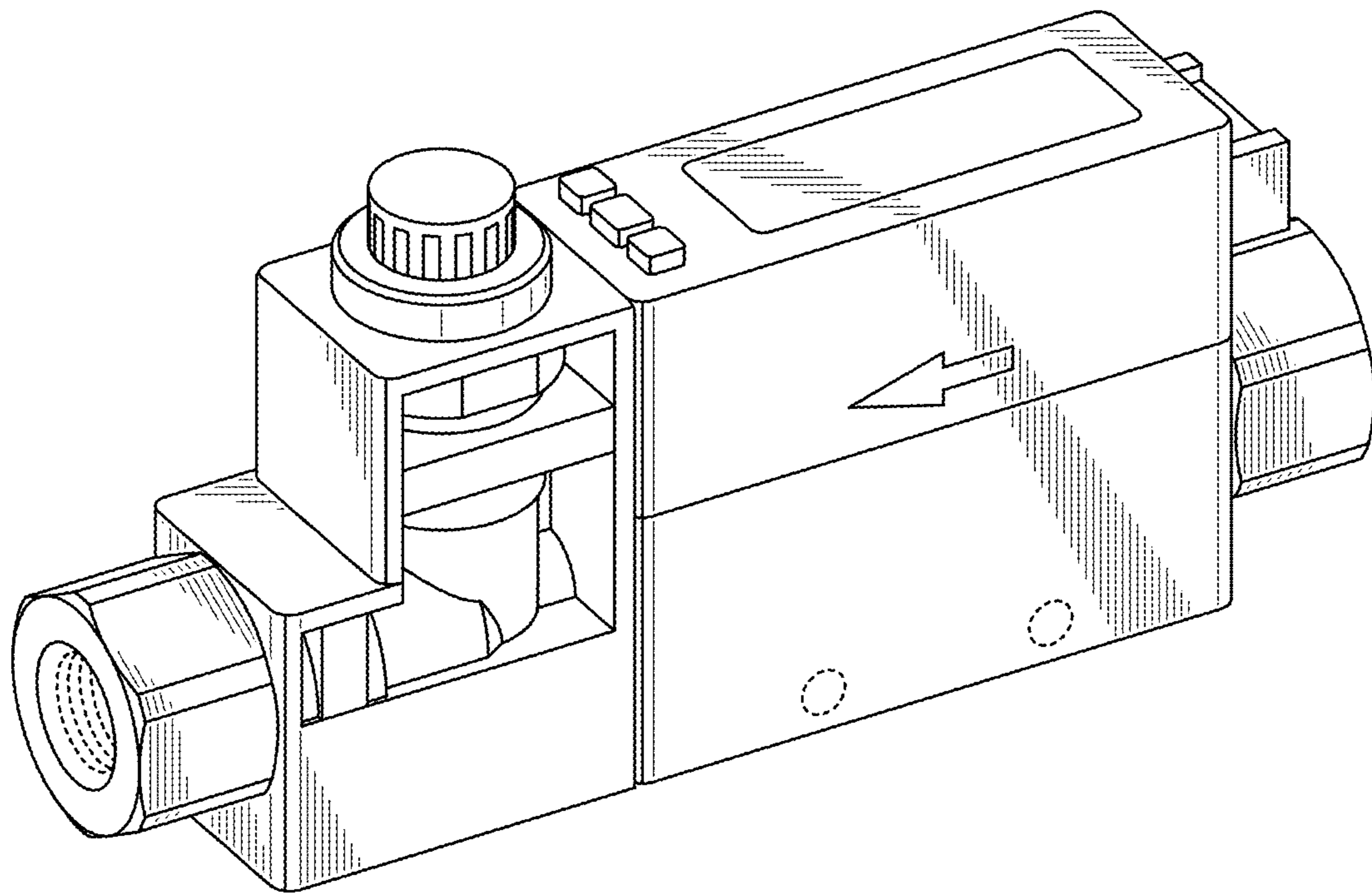

FIG. 26

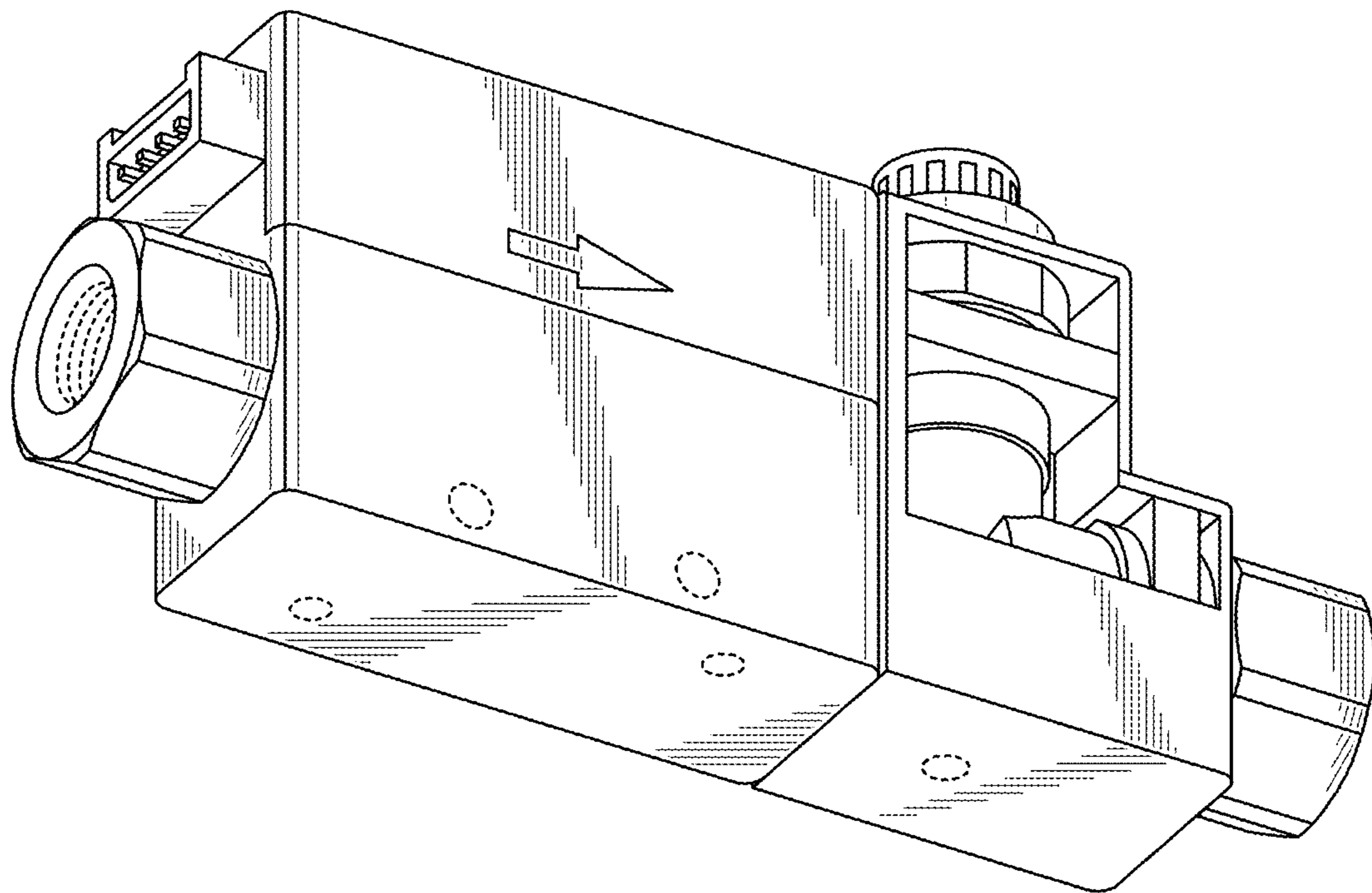

FIG. 27

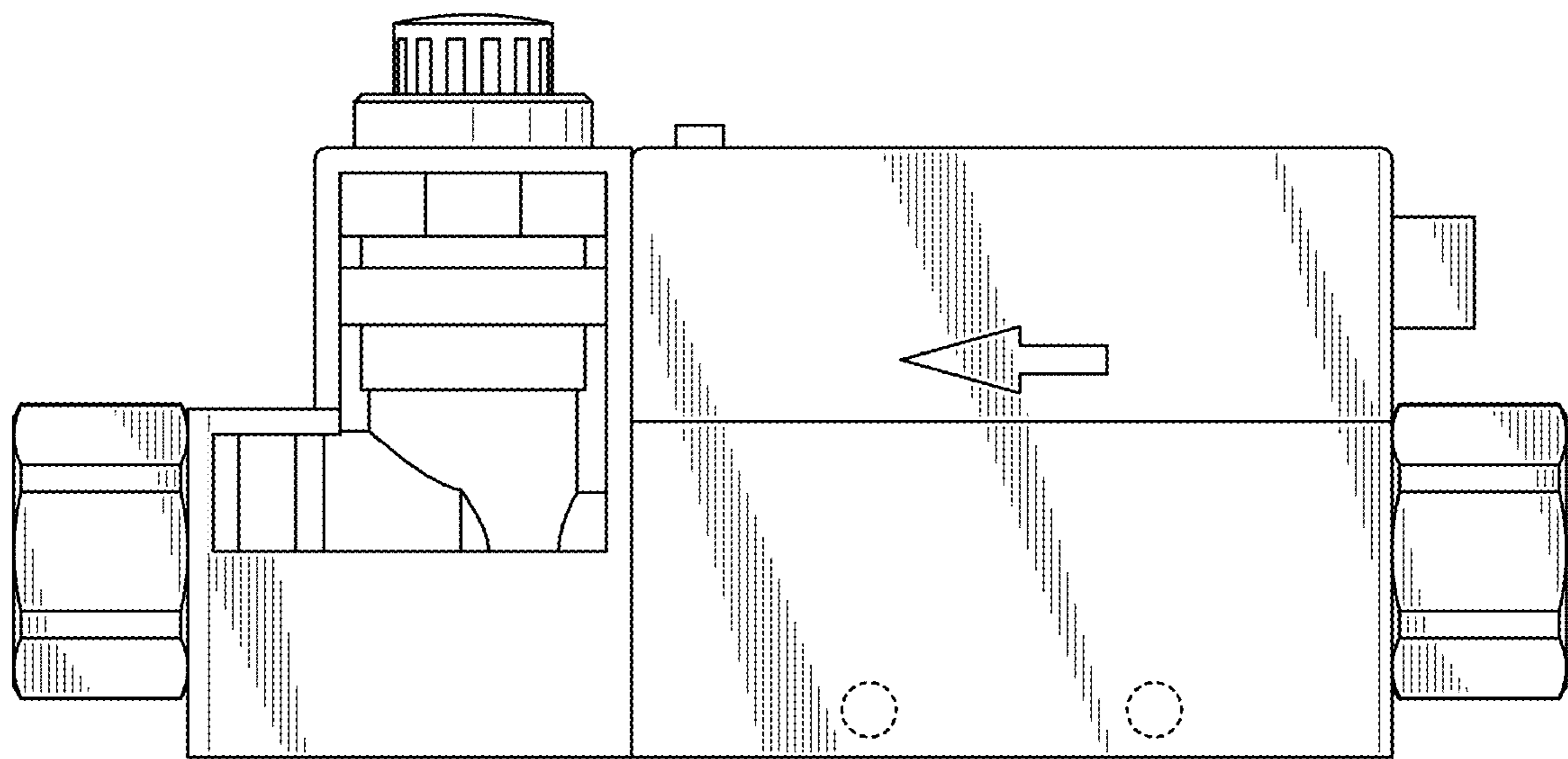

FIG. 28

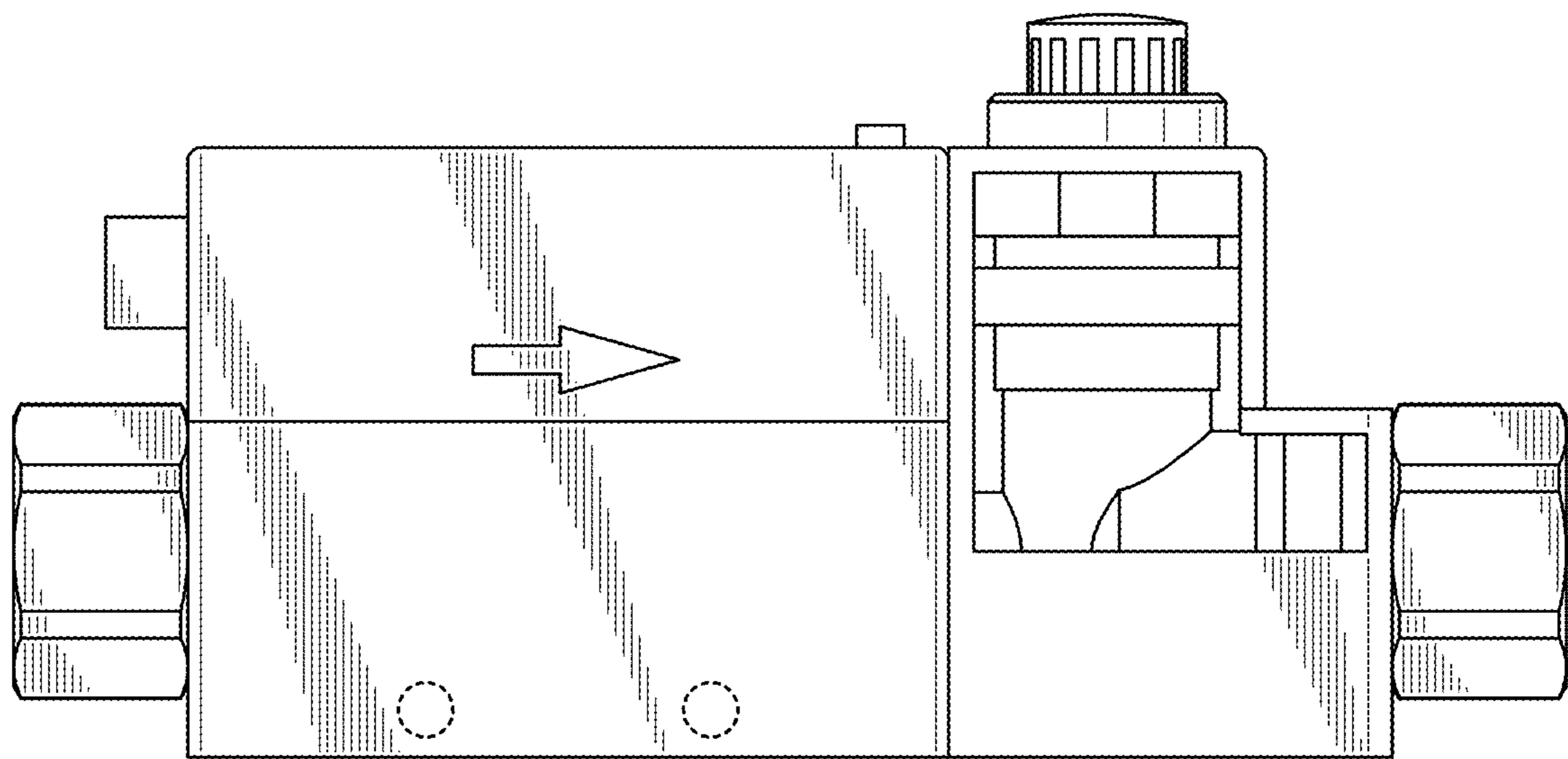

FIG. 29

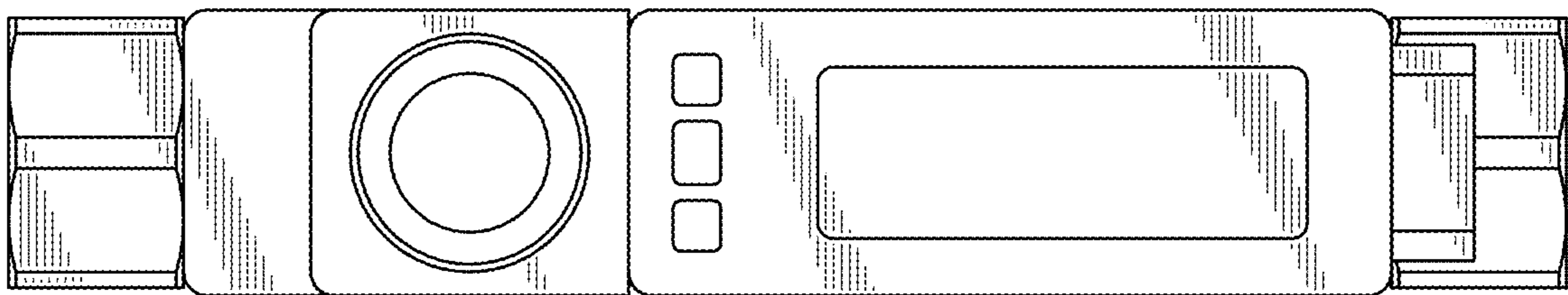

FIG. 30

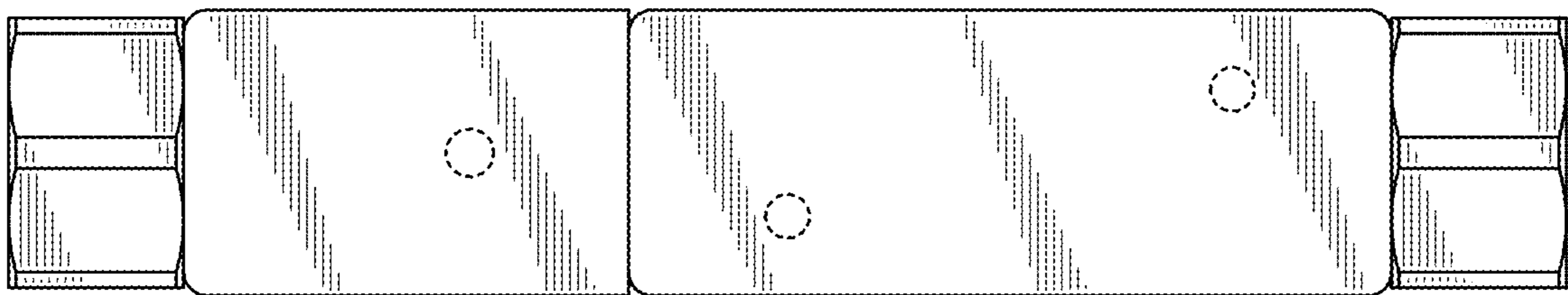

FIG. 31

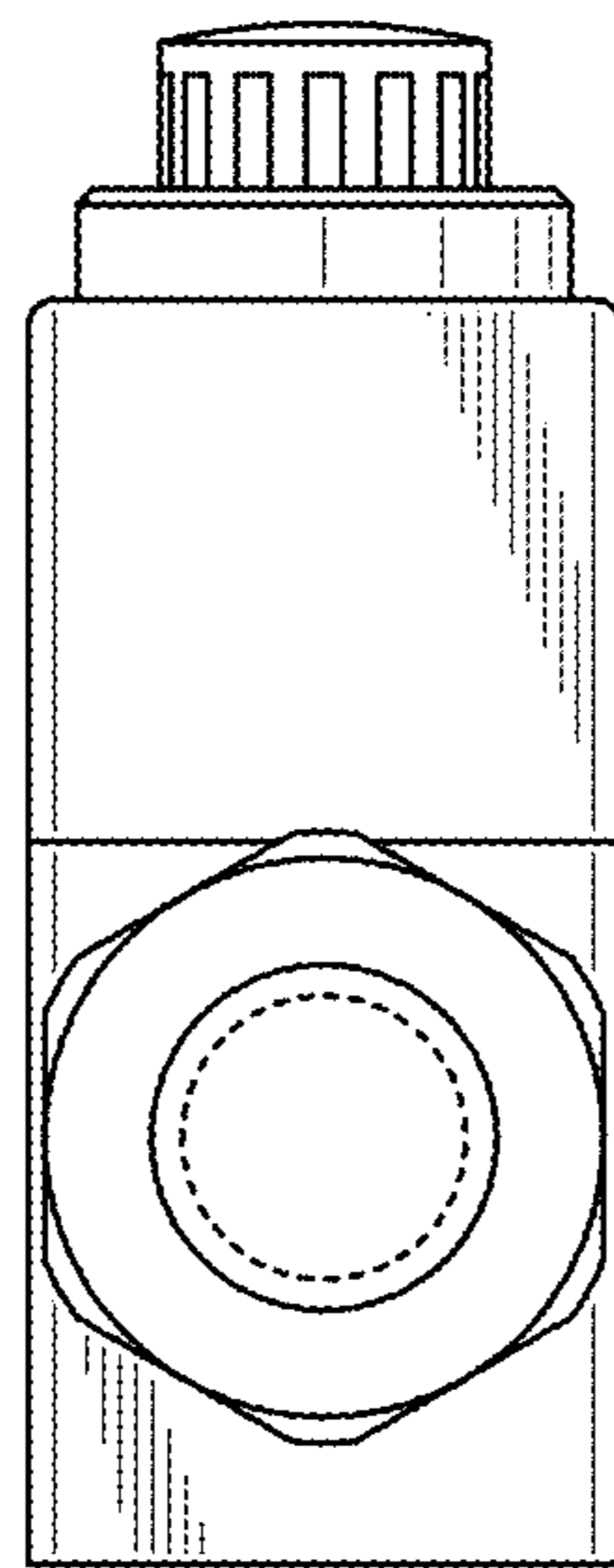

FIG. 32

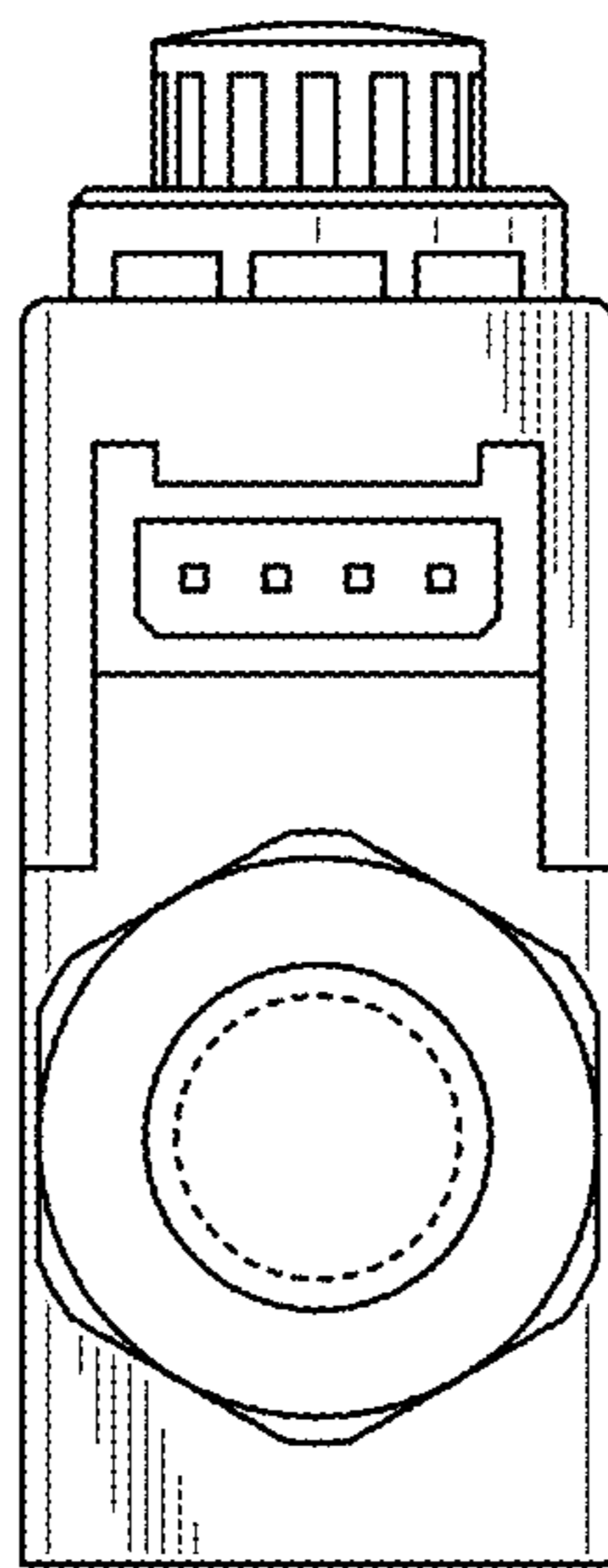

FIG. 33

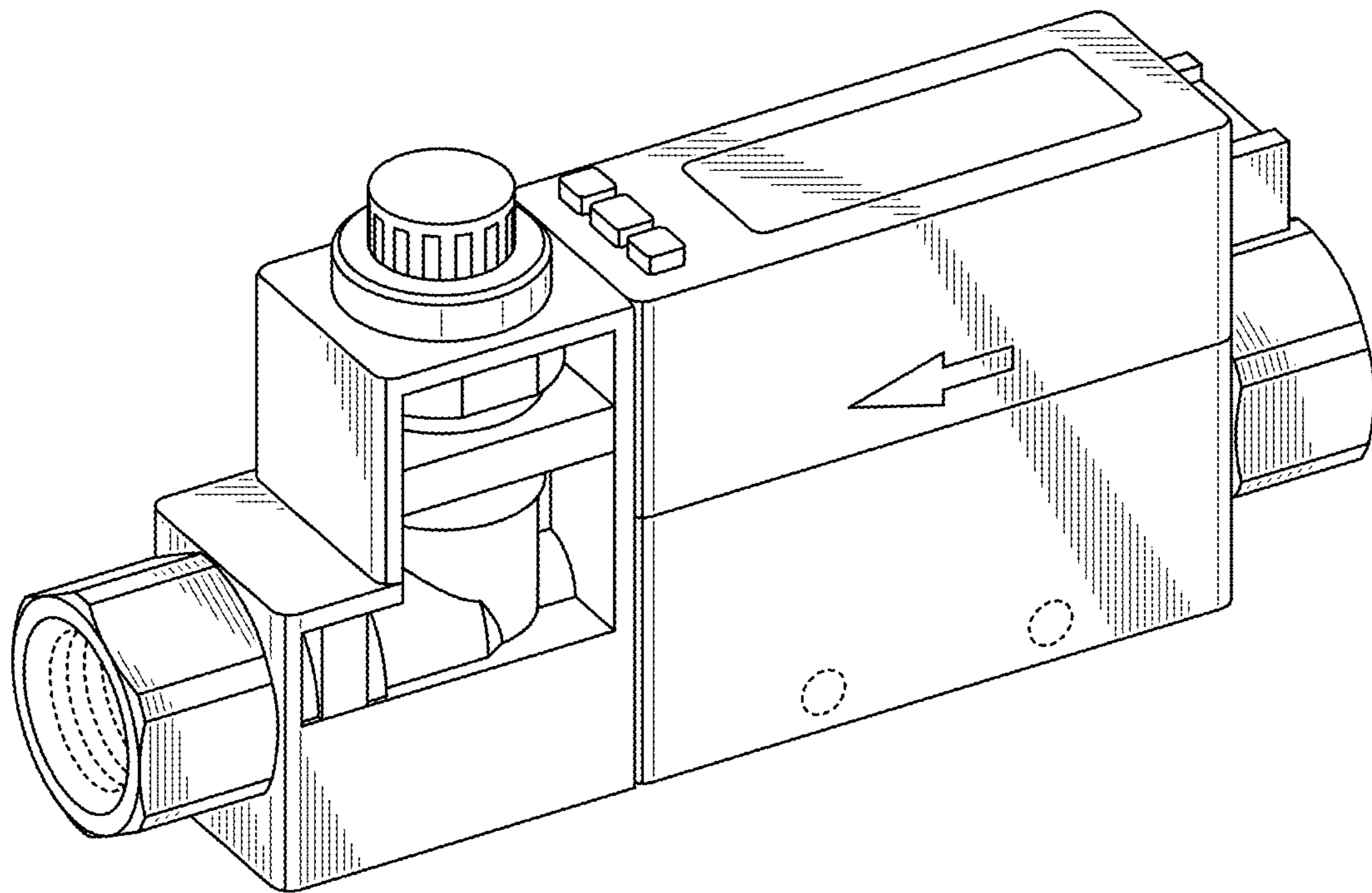

FIG. 34

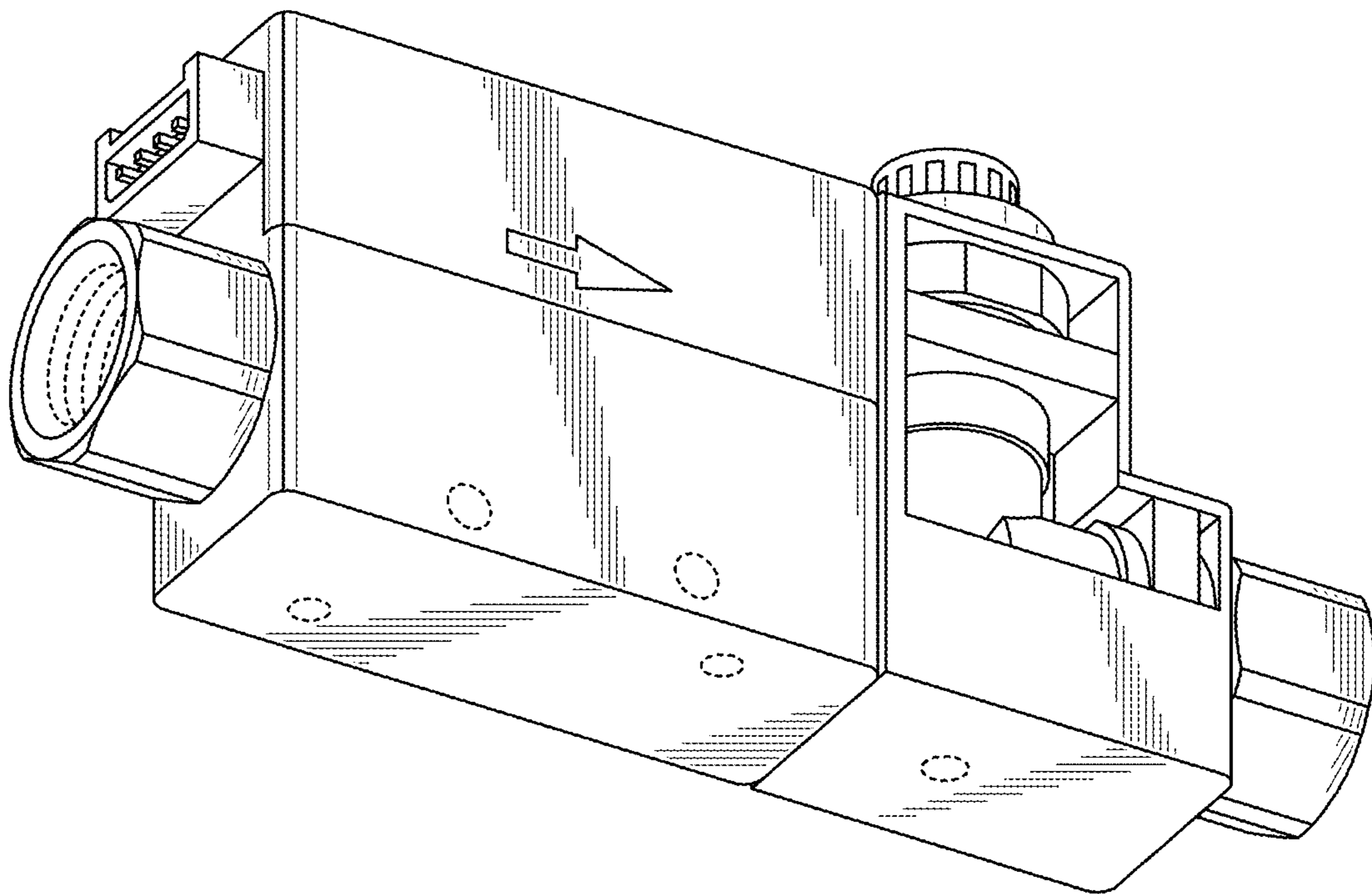

FIG. 35

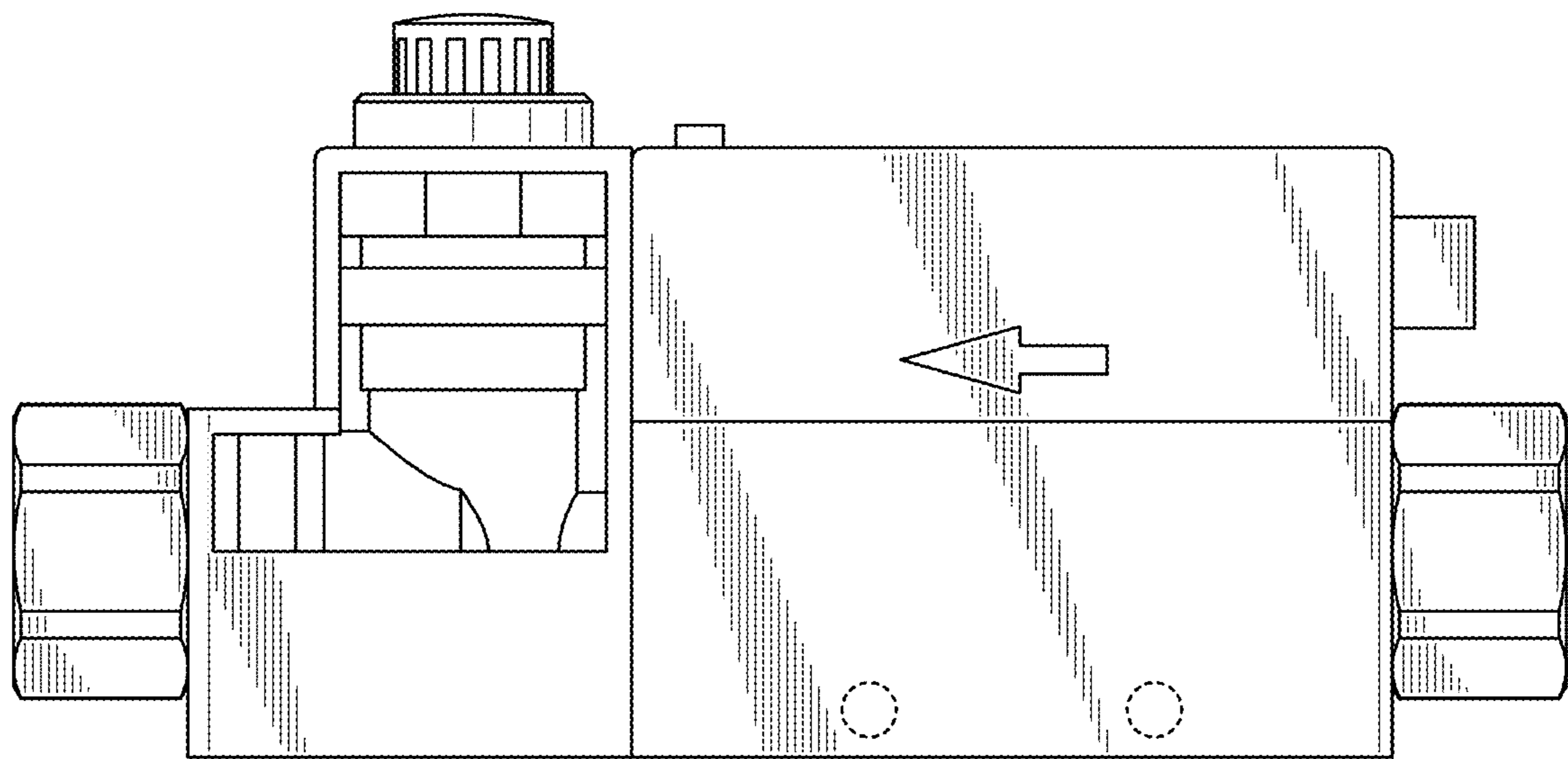

FIG. 36

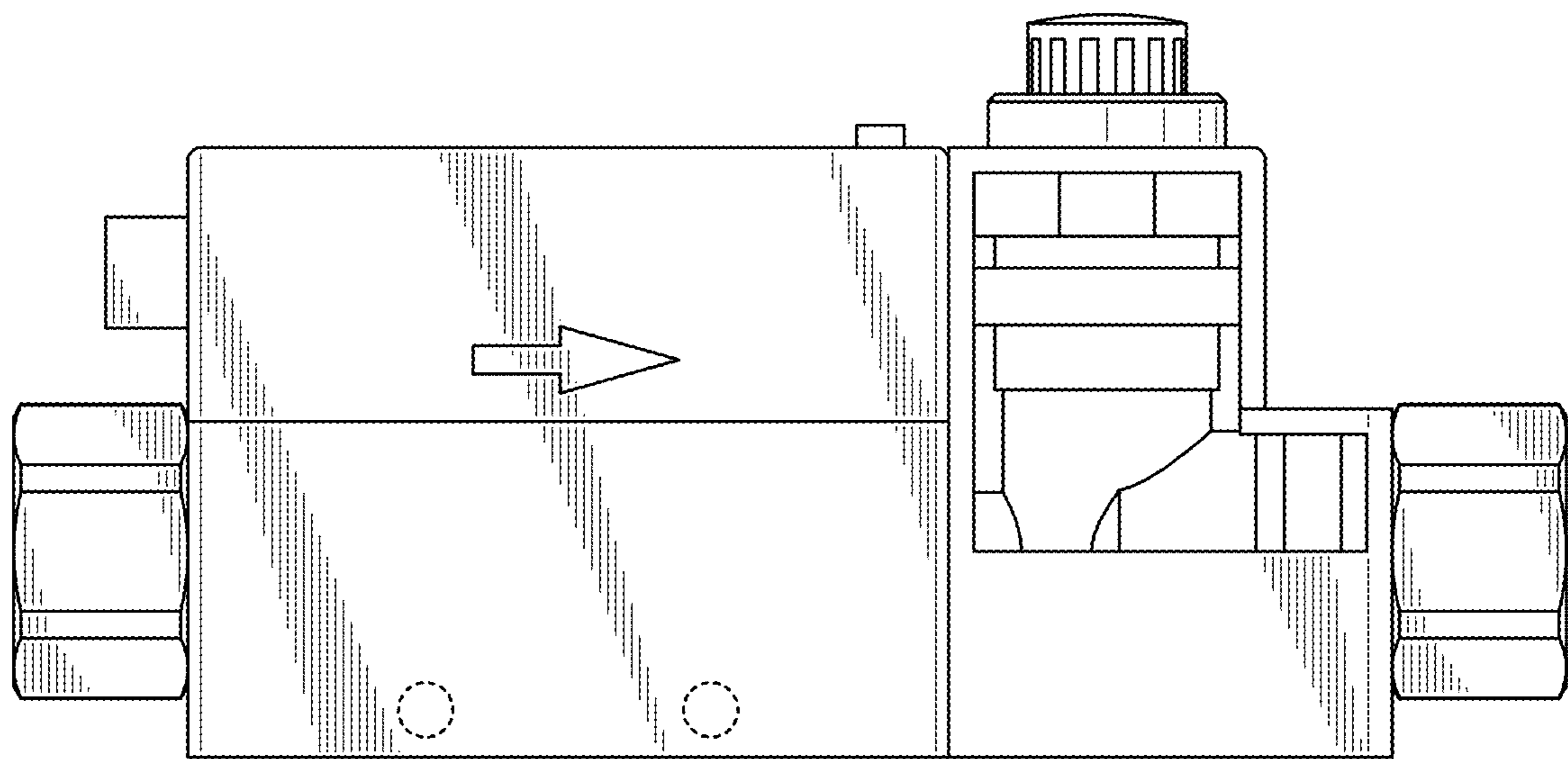

FIG. 37

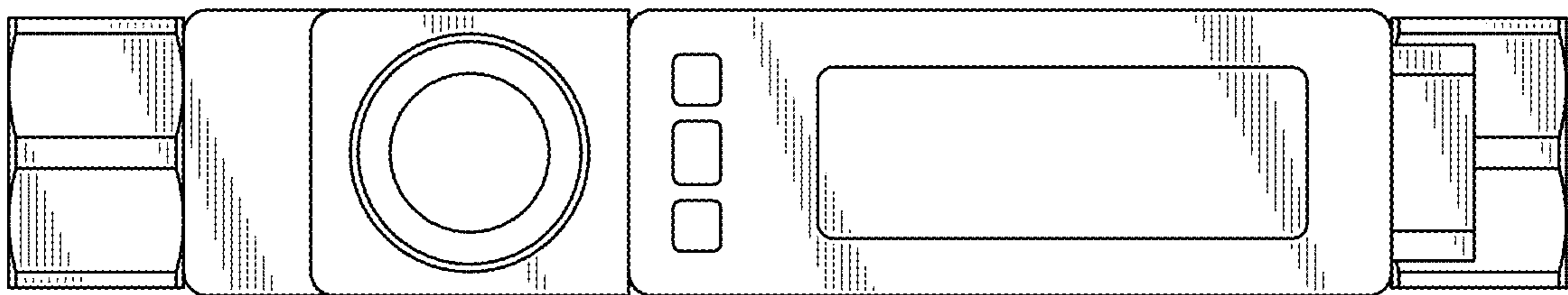

FIG. 38

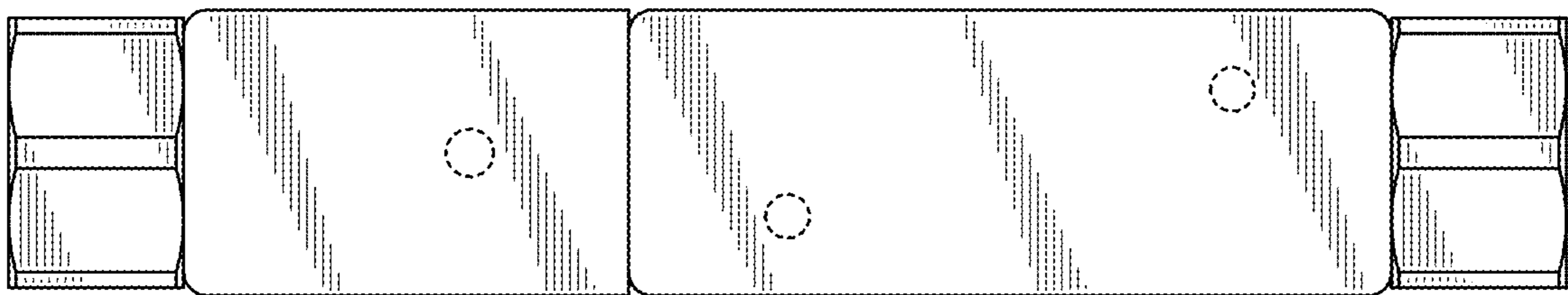

FIG. 39

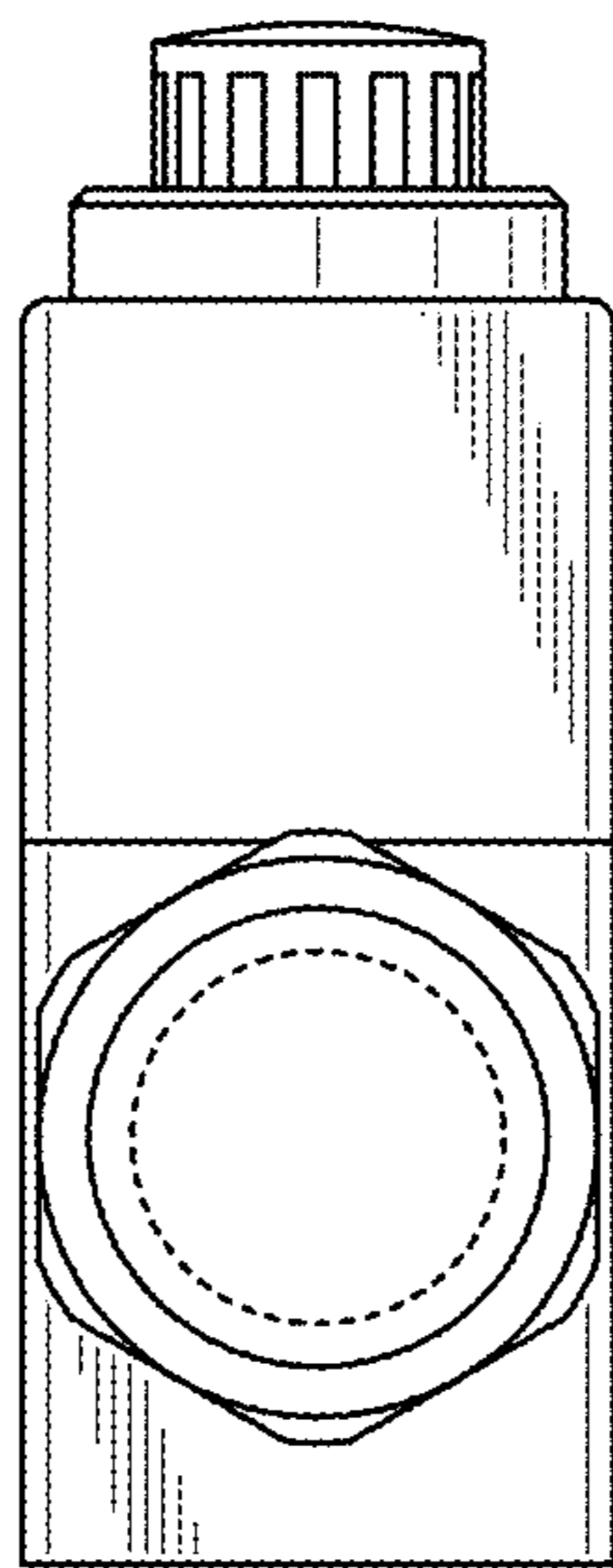

FIG. 40

