



US00D914273S

(12) **United States Design Patent** (10) **Patent No.:** **US D914,273 S**  
**Verleur et al.** (45) **Date of Patent:** **\*\* Mar. 23, 2021**

- (54) **VAPORIZER**
- (71) Applicant: **VMR Products LLC**, Miami, FL (US)
- (72) Inventors: **Jan Andries Verleur**, Miami, FL (US);  
**Dan Recio**, Miami Beach, FL (US);  
**Zhiyuan Liu**, Miami, FL (US); **Hans Verleur**, El Dorado, CA (US)
- (73) Assignee: **VMR Products LLC**, Miami, FL (US)
- (\*\*) Term: **15 Years**
- (21) Appl. No.: **29/683,338**
- (22) Filed: **Mar. 12, 2019**

**Related U.S. Application Data**

- (63) Continuation of application No. 29/615,506, filed on Aug. 29, 2017, now Pat. No. Des. 843,650.
- (51) **LOC (13) Cl.** ..... **27-02**
- (52) **U.S. Cl.**  
USPC ..... **D27/162**
- (58) **Field of Classification Search**  
USPC ..... D27/100, 101, 162, 163-169, 172-193,  
D27/194; D23/355, 356, 359, 360  
CPC ..... A24F 47/008; A24F 40/10; A24F 47/002;  
A24F 15/12; A24F 47/006; A24F 40/00  
See application file for complete search history.

**References Cited**

**U.S. PATENT DOCUMENTS**

D532,927 S *	11/2006	Sann	.....	D27/101
D591,899 S	5/2009	Bray et al.		
D668,534 S	10/2012	Collins		
D706,976 S	6/2014	Wu		
D742,021 S *	10/2015	Labuschagne	.....	D24/200
D752,285 S	3/2016	Doster		
D752,286 S	3/2016	Doster		
D757,352 S *	5/2016	Bagai	.....	D27/101
D757,353 S *	5/2016	Nunnally	.....	D27/101
D757,994 S *	5/2016	Moradian	.....	D27/101

D762,003 S *	7/2016	Lomeli	.....	D27/163
9,399,110 B2 *	7/2016	Goodman	.....	A61M 16/1075
D772,477 S	11/2016	Shin		
D772,480 S	11/2016	Hua		
D773,729 S *	12/2016	Jordan	.....	D27/194
D776,338 S *	1/2017	Lomeli	.....	D27/163
D780,991 S *	3/2017	Liu	.....	D27/101
D792,643 S *	7/2017	Wong	.....	D27/101
D792,644 S *	7/2017	Jordan et al.	.....	D27/101
D801,507 S	10/2017	Kelnhofer		
D804,717 S	12/2017	Wang et al.		
D806,311 S	12/2017	Smith		
D811,003 S	2/2018	Folyan		

(Continued)

**OTHER PUBLICATIONS**

Borosilicate Triangle Capillary Glass Tubing and Rod. By Jinan Honhai Glass company. dated 2019. found online [Aug. 28, 2020] <https://honhai060306.en.made-in-china.com/product/CobxsGZKSNAW/China-Borosilicate-Triangle-Capillary-Glass-Tubing-and-Rod.html>.\*

*Primary Examiner* — Marissa J Cash

(74) *Attorney, Agent, or Firm* — Mintz Levin Cohn Ferris Glovsky and Popeo, P.C.

(57) **CLAIM**

The ornamental design for a vaporizer, as shown and described.

**DESCRIPTION**

FIG. 1 is a perspective view of a vaporizer showing our new design;  
FIG. 2 is a front elevational view thereof;  
FIG. 3 is a rear elevational view thereof;  
FIG. 4 is a top plan view thereof;  
FIG. 5 is a bottom plan view thereof;  
FIG. 6 is a left side elevational view thereof; and,  
FIG. 7 is a right side elevational view thereof.  
The broken lines illustrate portions of the vaporizer that form no part of the claimed design.

**1 Claim, 3 Drawing Sheets**

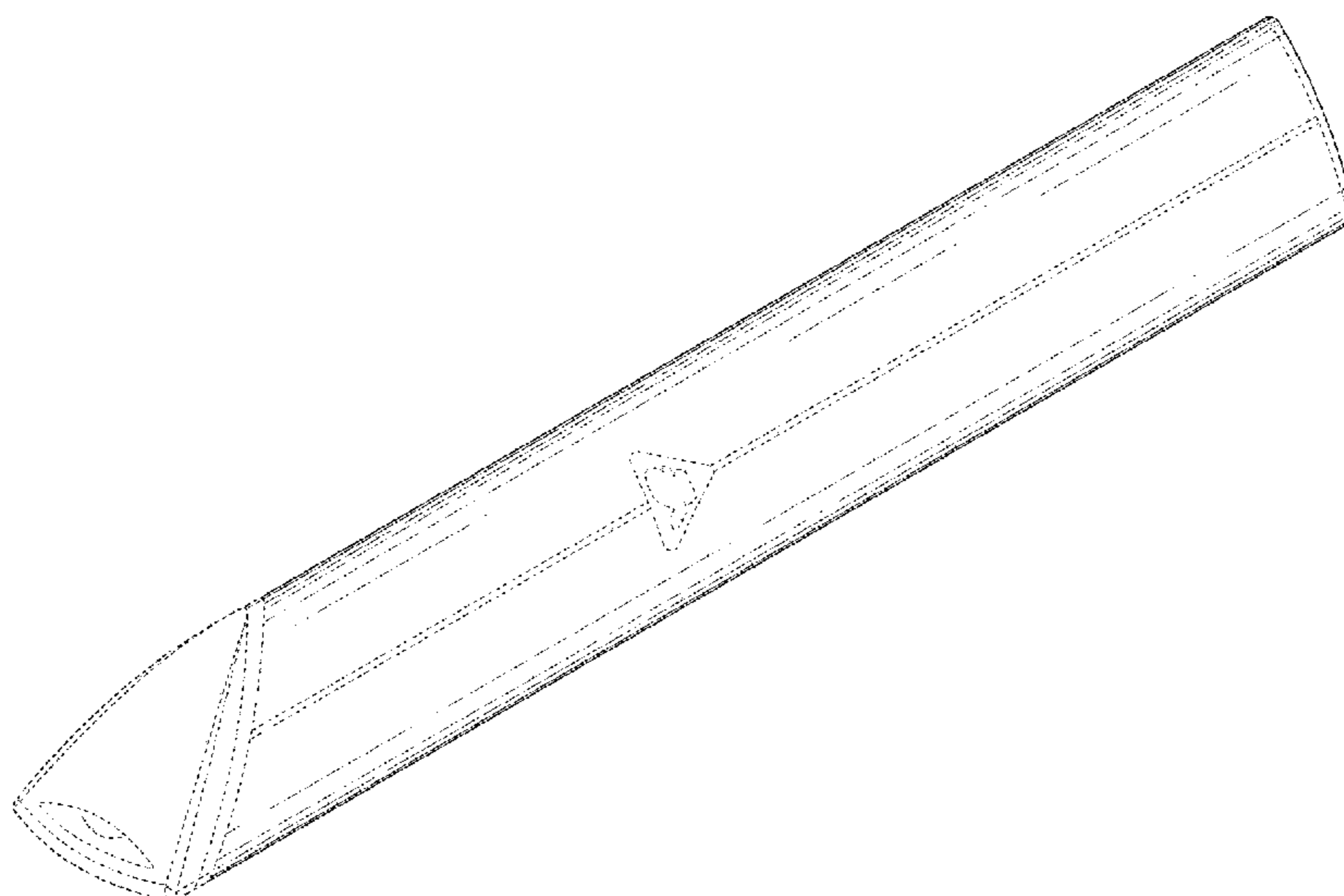

(56)

**References Cited**

## U.S. PATENT DOCUMENTS

D816,267	S	4/2018	Fornarelli	
D819,263	S *	5/2018	Zhu .....	D27/101
D822,271	S *	7/2018	Eksouzian .....	D27/101
D822,592	S *	7/2018	Cavalli, III .....	D13/103
D825,099	S *	8/2018	Wright .....	D27/101
D827,195	S *	8/2018	Chen .....	D27/101
D829,980	S *	10/2018	Qiu .....	D27/162
D832,500	S *	10/2018	Qiu .....	D27/162
D834,246	S *	11/2018	Qiu .....	D27/162
D835,337	S *	12/2018	Beer .....	D27/162
D843,650	S *	3/2019	Verleur .....	D27/172
D844,229	S *	3/2019	Sherwood .....	D27/162
10,292,436	B2 *	5/2019	Cirillo .....	A24D 1/14
D861,239	S *	9/2019	Chen .....	D27/101
D861,240	S *	9/2019	Qiu .....	D27/101
10,398,169	B2 *	9/2019	Nelson .....	B29C 65/08
D868,361	S *	11/2019	Stone .....	D27/101
D870,369	S *	12/2019	Greenbaum .....	D27/162
D870,372	S *	12/2019	Zhu .....	D27/167
D876,004	S *	2/2020	Wang .....	D27/101
10,588,356	B2 *	3/2020	Harrison .....	A24F 7/02
D881,457	S *	4/2020	Ouyang .....	D27/162
10,609,958	B2 *	4/2020	Robinson .....	A24F 47/008
10,631,576	B1 *	4/2020	Chen .....	A24F 40/42
D883,566	S *	5/2020	Filleul .....	D27/162
10,701,973	B2 *	7/2020	Lee .....	A24F 9/16
10,721,973	B1 *	7/2020	Hermiz .....	G05B 15/02
10,743,589	B1 *	8/2020	Hermiz .....	G08B 5/22
2013/0140200	A1 *	6/2013	Scatterday .....	A24F 15/00 206/265
2016/0374396	A1 *	12/2016	Jordan .....	A24F 47/008 392/386
2018/0153221	A1 *	6/2018	Verleur .....	A24F 47/008
2018/0271151	A1 *	9/2018	Litten .....	H05B 1/0283

\* cited by examiner

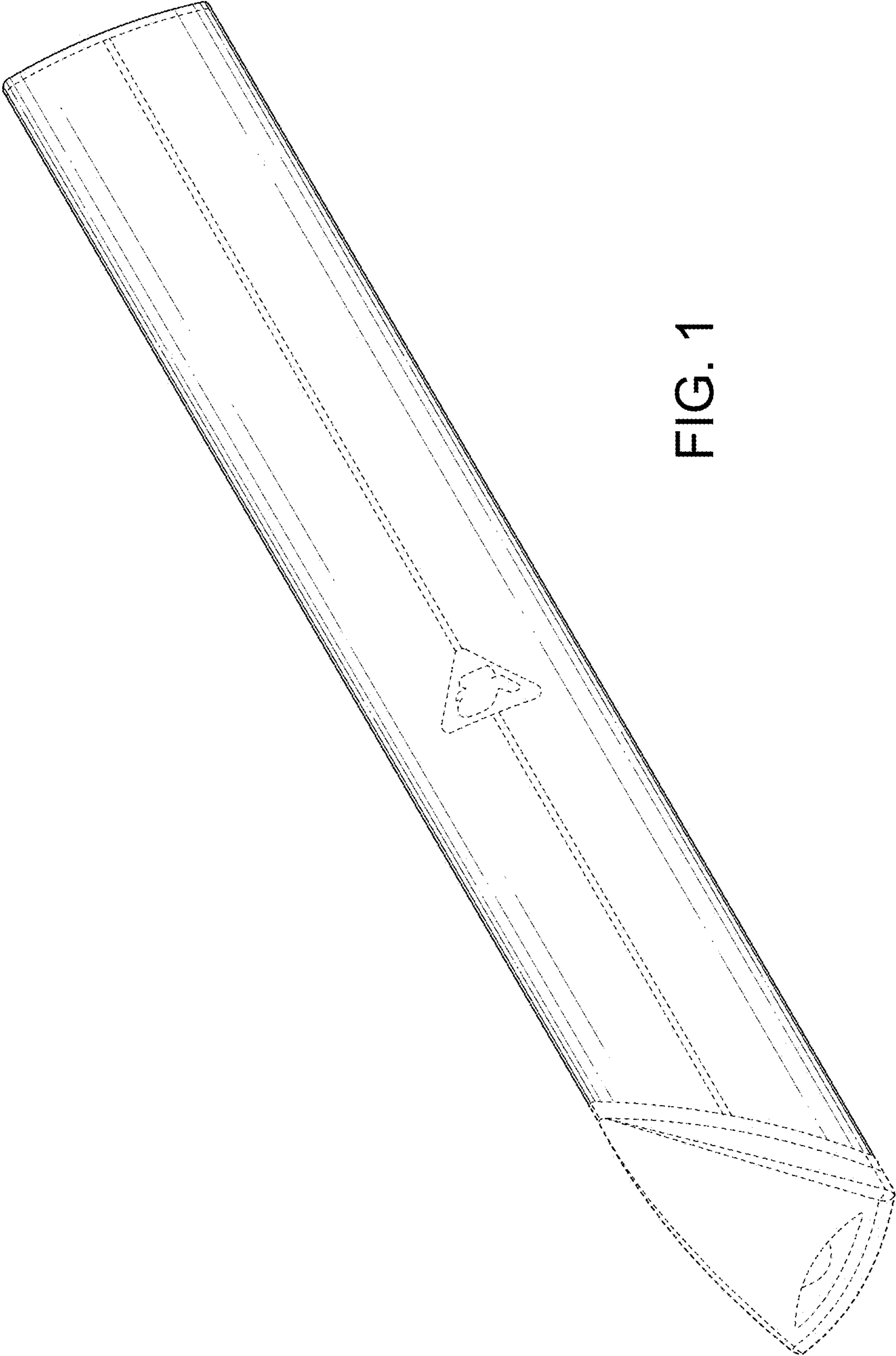

FIG. 1

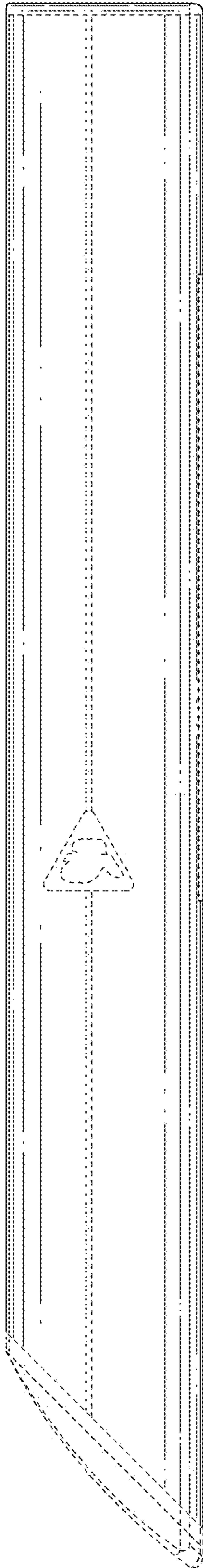

FIG. 2

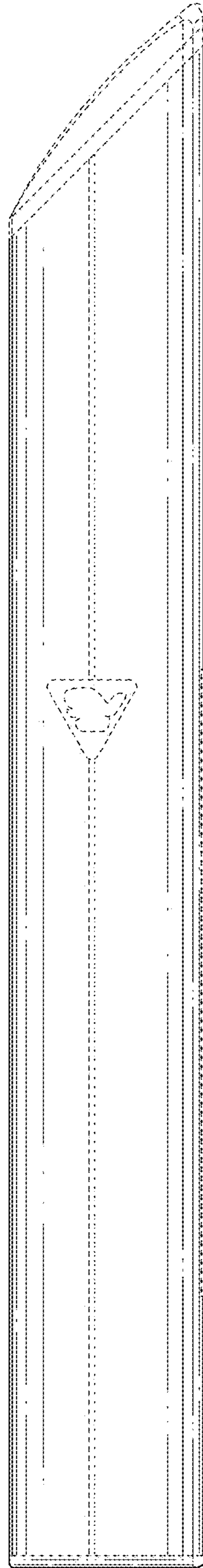

FIG. 3

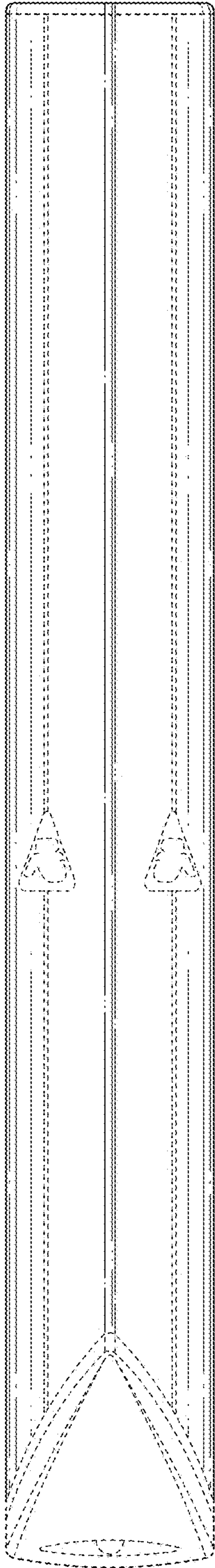

FIG. 4

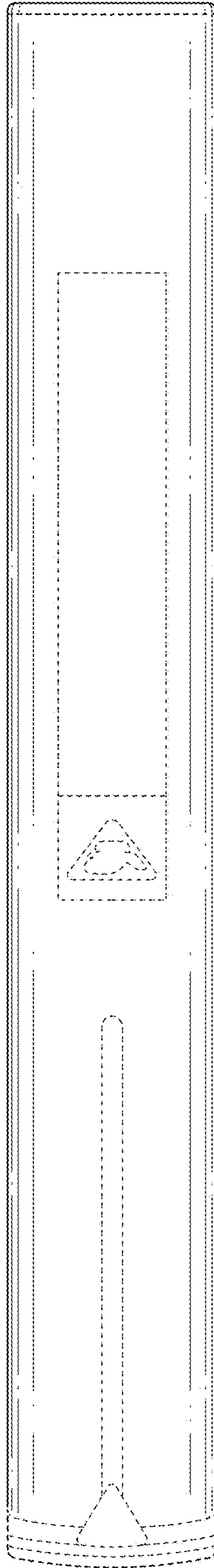

FIG. 5

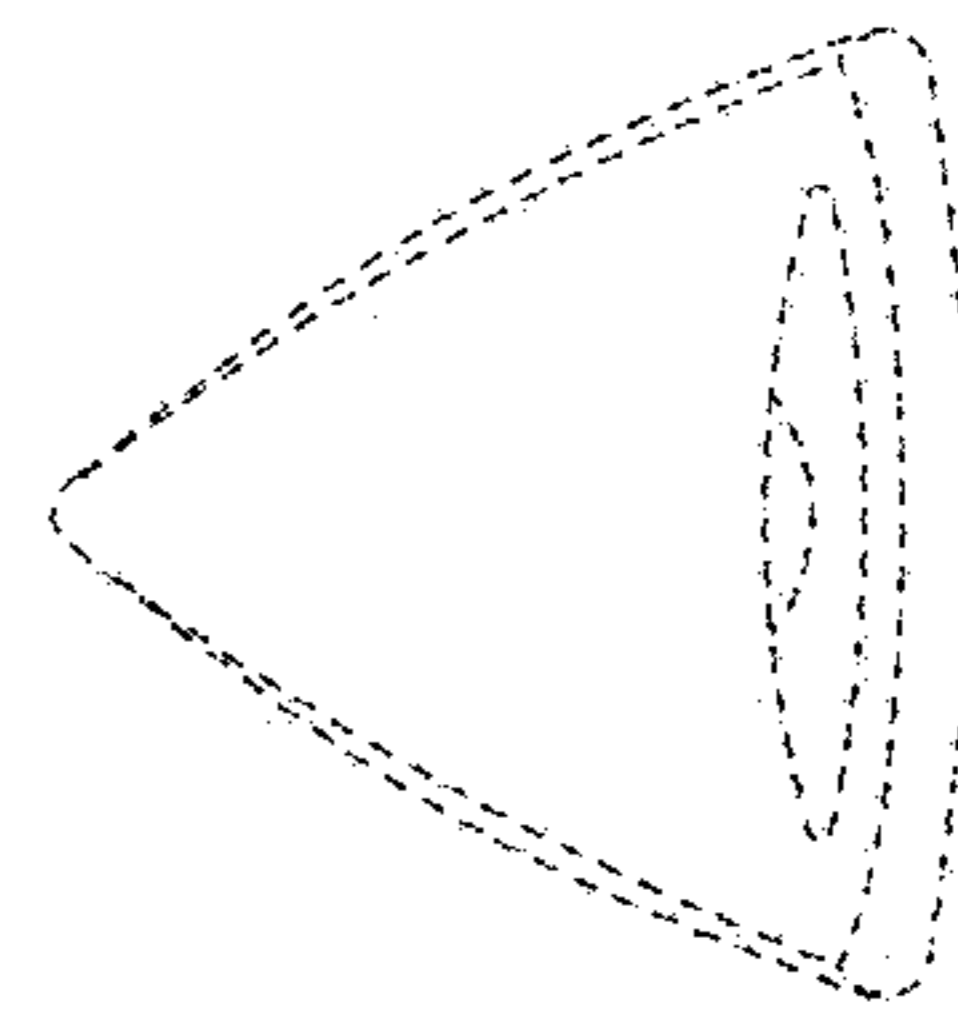

FIG. 6

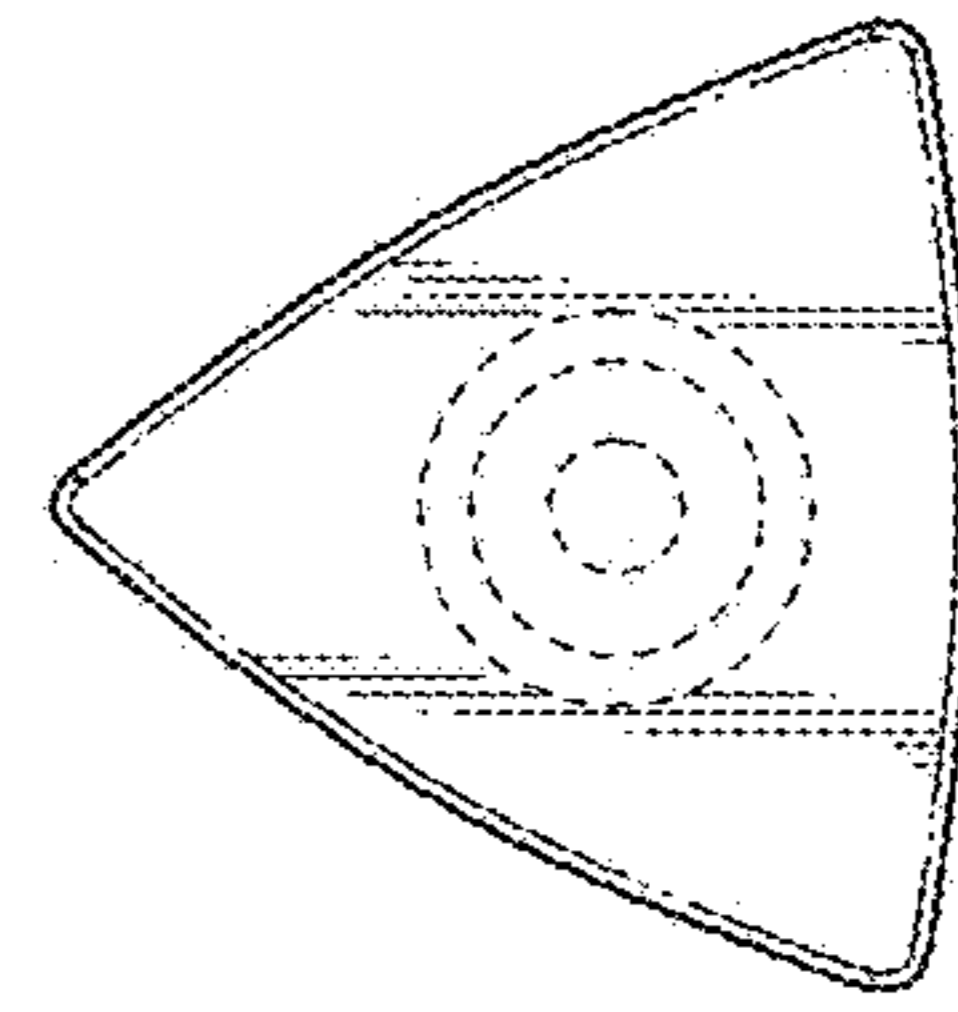

FIG. 7