



US00D913986S

(12) **United States Design Patent** (10) **Patent No.:** **US D913,986 S**  
**Suzuki** (45) **Date of Patent:** **\*\* Mar. 23, 2021**

(54) **SPEAKER**

(71) Applicant: **SONY CORPORATION**, Tokyo (JP)

(72) Inventor: **Satoshi Suzuki**, Kanagawa (JP)

(73) Assignee: **SONY CORPORATION**, Tokyo (JP)

(\*\*) Term: **15 Years**

(21) Appl. No.: **29/709,839**

(22) Filed: **Oct. 17, 2019**

(30) **Foreign Application Priority Data**

Aug. 30, 2019 (JP) ..... D2019-019349 U

(51) **LOC (13) Cl.** ..... **14-01**

(52) **U.S. Cl.**  
USPC ..... **D14/204; D14/214**

(58) **Field of Classification Search**  
USPC ..... D14/204–216, 155–159, 160–173, 187,  
D14/188, 203.1–203.8, 217–222  
CPC ..... H04R 1/02; H04R 1/021; H04R 1/023;  
H04R 5/00; H04R 9/06; H04R 2420/07  
See application file for complete search history.

(56) **References Cited**

**U.S. PATENT DOCUMENTS**

D291,925 S *	9/1987	Dacanay	.....	D26/24
D297,641 S *	9/1988	Sogabe	.....	D14/128
D321,527 S *	11/1991	Kurozumi	.....	D16/234
D478,059 S	8/2003	Oikawa		
D478,565 S	8/2003	Oikawa		
D589,882 S *	4/2009	Kok	.....	D13/133
D696,630 S *	12/2013	Zhang	.....	D13/133
D860,295 S *	9/2019	Starling	.....	D16/225
D891,391 S *	7/2020	Haberlah	.....	D14/188
2019/0316668 A1 *	10/2019	Suzuki	.....	F04B 1/0439

**OTHER PUBLICATIONS**

Experience Superior . . . System, Sep. 5, 2019 [online], [retrieved Oct. 29, 2020], Retrieved from Internet, URL: <https://www.

prnewswire.com/news-releases/experience-superior-sound-with-sony-electronics-signature-series-sa-z1-near-field-powered-speaker-system-300912165.html> (Year: 2019).\*

(Continued)

*Primary Examiner* — Barbara Fox

*Assistant Examiner* — Aram Kwon

(74) *Attorney, Agent, or Firm* — Michael Best and Friedrich LLP

(57) **CLAIM**

The ornamental design for a speaker, as shown and described.

**DESCRIPTION**

FIG. 1 is a front, top, right perspective view of a first embodiment of a speaker showing my new design; FIG. 2 is a rear, top, right perspective view thereof; FIG. 3 is a front elevational view thereof; FIG. 4 is a rear elevational view thereof; FIG. 5 is a left side elevational view thereof; FIG. 6 is a right side elevational view thereof; and FIG. 7 is a top plan view thereof. FIG. 8 is a bottom plan view thereof. FIG. 9 is a front, top, right perspective view of a second embodiment of a speaker showing my new design; FIG. 10 is a rear, top, right perspective view thereof; FIG. 11 is a front elevational view thereof; FIG. 12 is a rear elevational view thereof; FIG. 13 is a left side elevational view thereof; FIG. 14 is a right side elevational view thereof; and FIG. 15 is a top plan view thereof; and, FIG. 16 is a bottom plan view thereof. The broken lines illustrating portions of the speaker form no part of the claimed design.

**1 Claim, 16 Drawing Sheets**

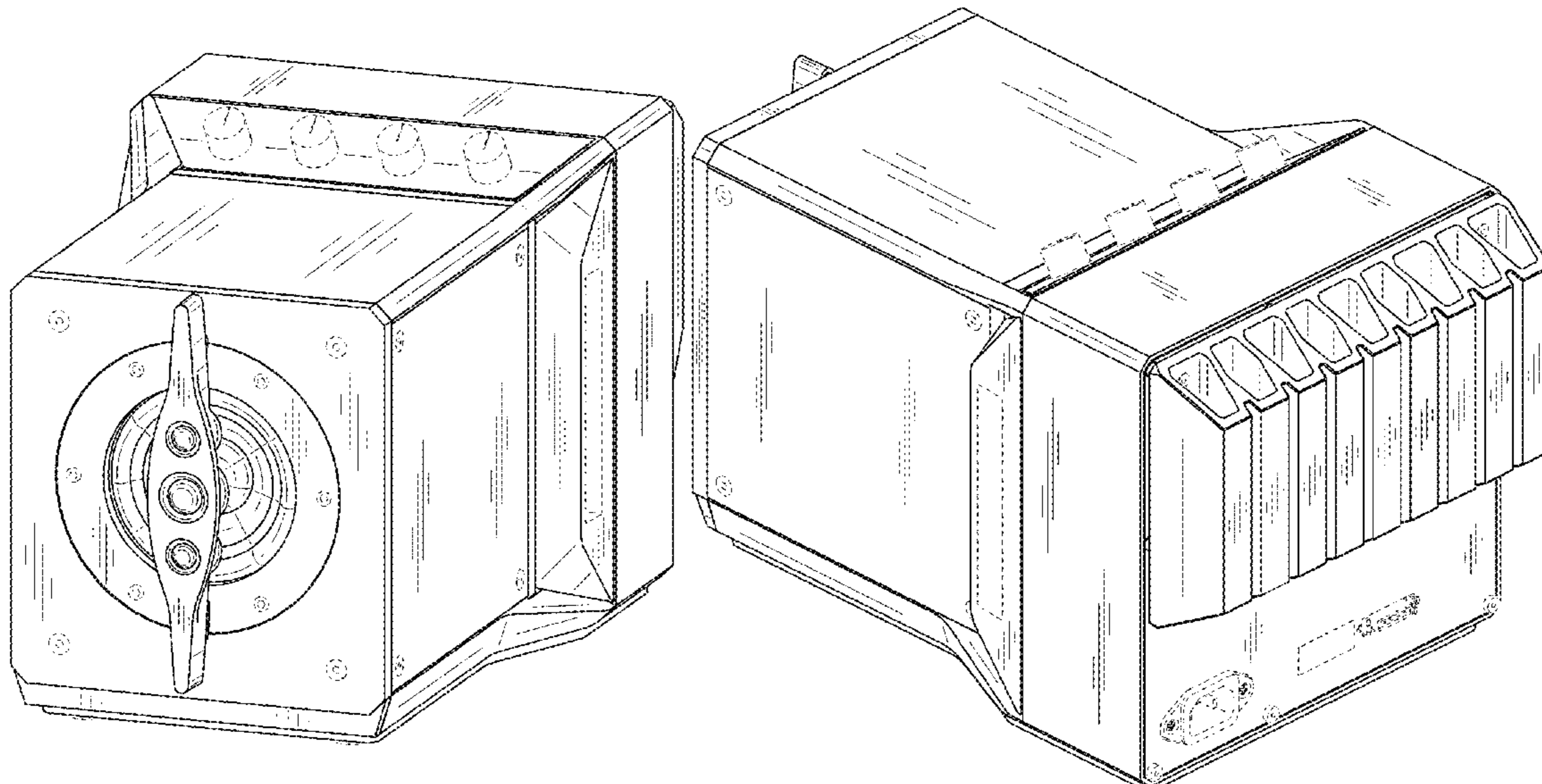

(56)

**References Cited**

OTHER PUBLICATIONS

Sony SA-Z1: The Pinnacle of Near Field Listening, Dec. 19, 2019 [online], [retrieved Oct. 29, 2020], Retrieved from Internet, URL: <<https://www.designlisticle.com/sony-sa-z1-the-pinnacle-of-near-field-listening/>> (Year: 2019).\*

Tsuzumi Drum-Inspired Speakers, Sep. 8, 2019 [online], [retrieved Oct. 29, 2020], Retrieved from Internet, URL: <<https://www.trendhunter.com/trends/sony-saz1>> (Year: 2019).\*

\* cited by examiner

FIG. 1

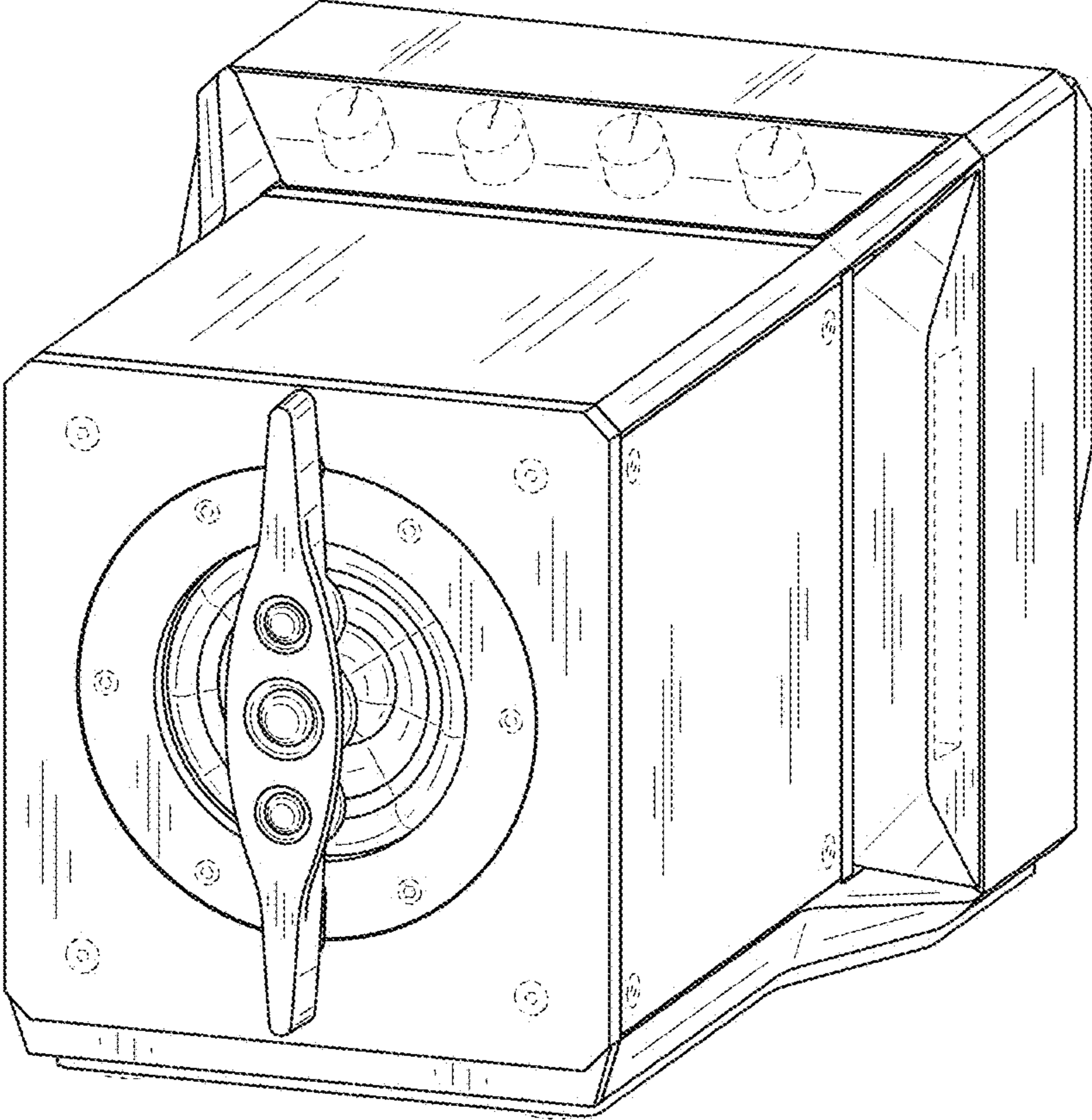

FIG.2

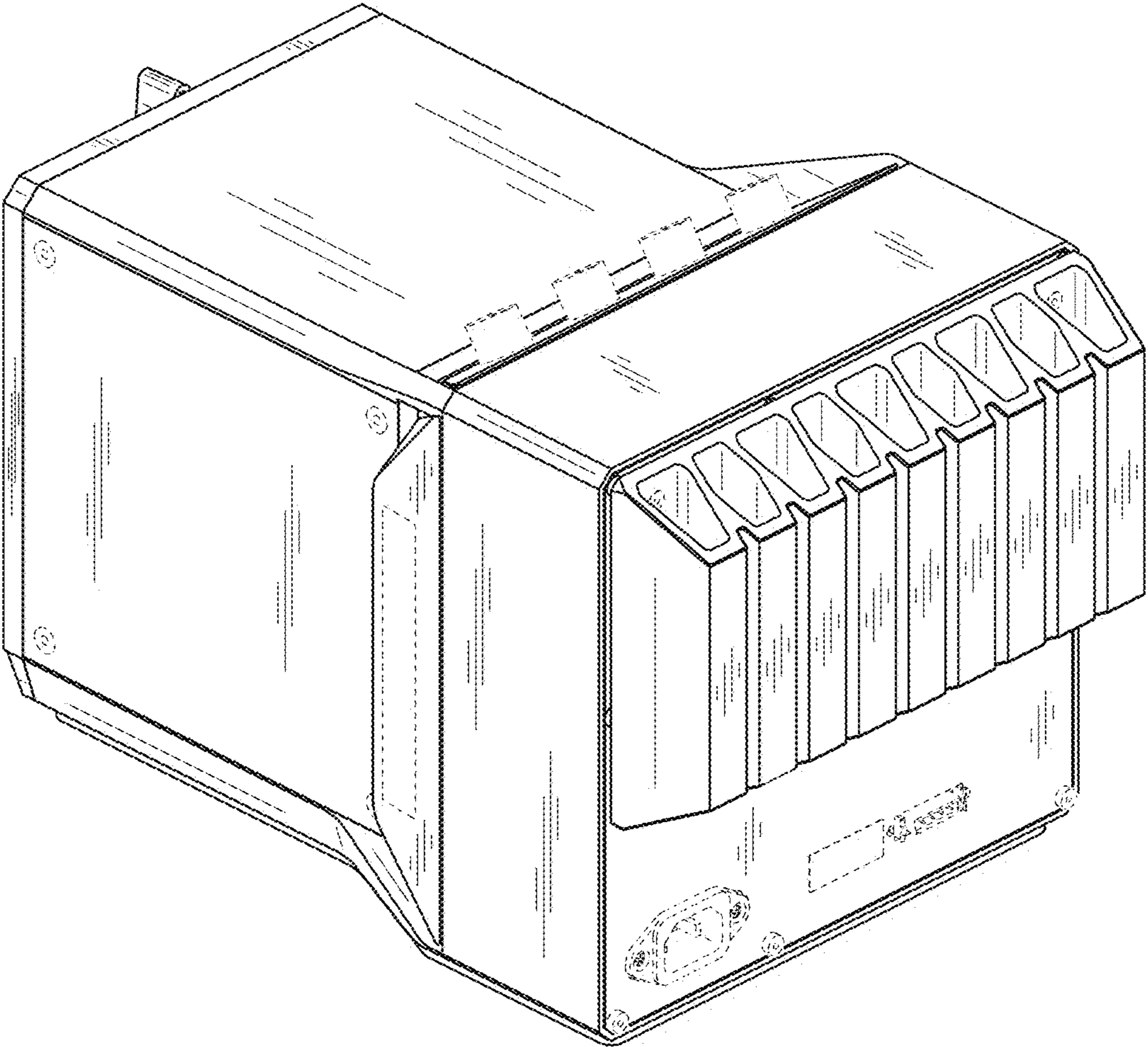

FIG.3

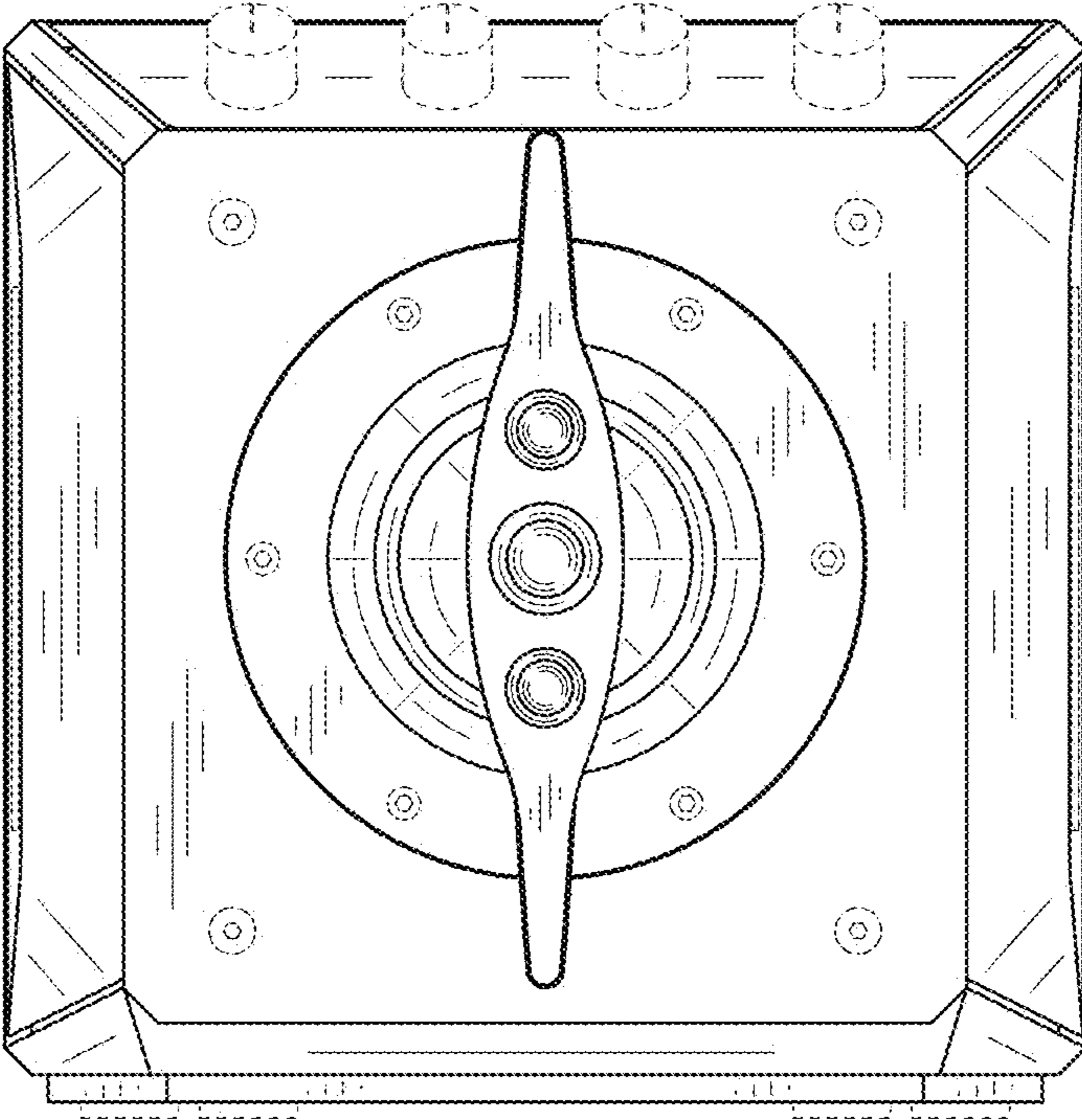

FIG.4

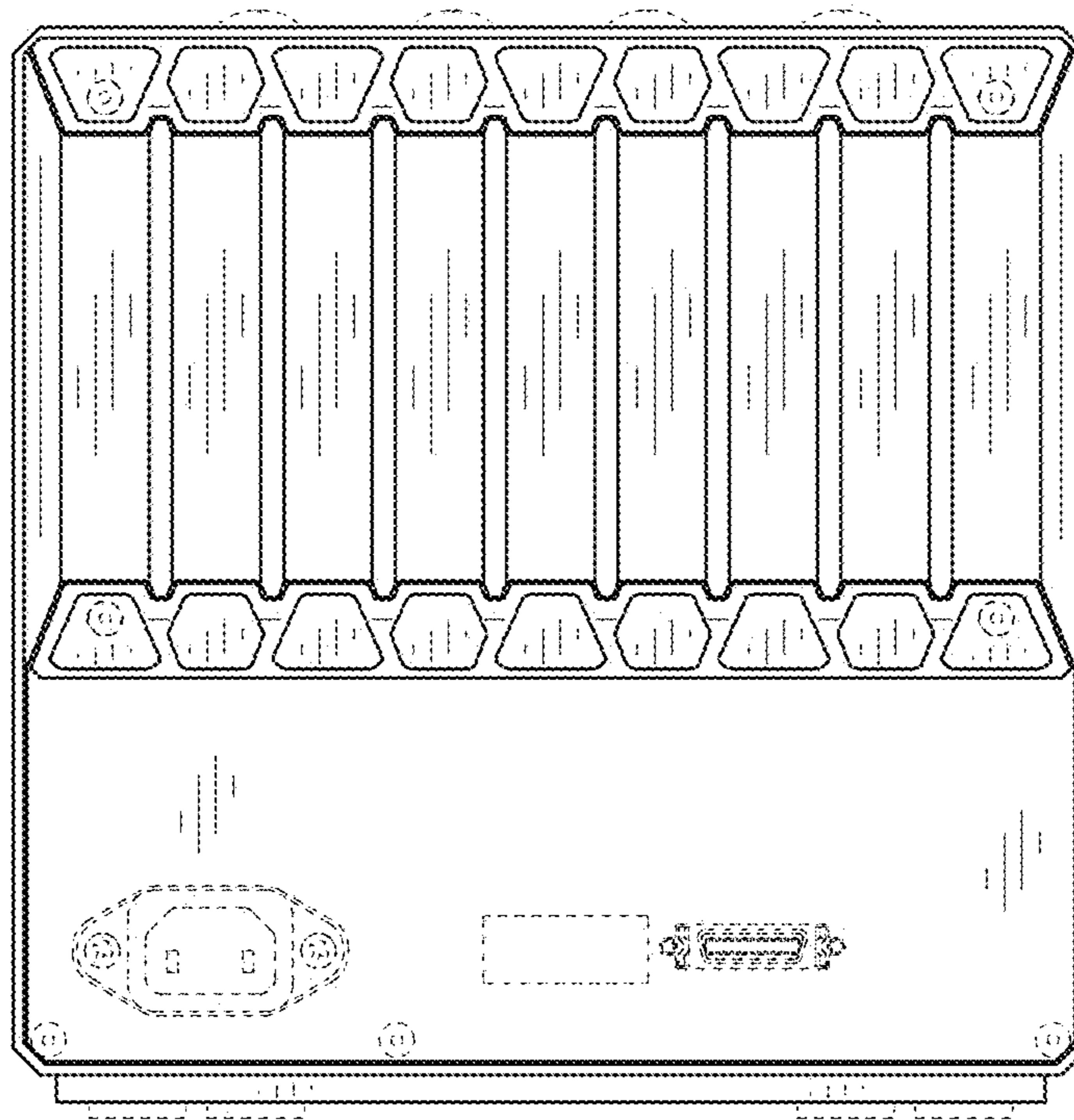

FIG.5

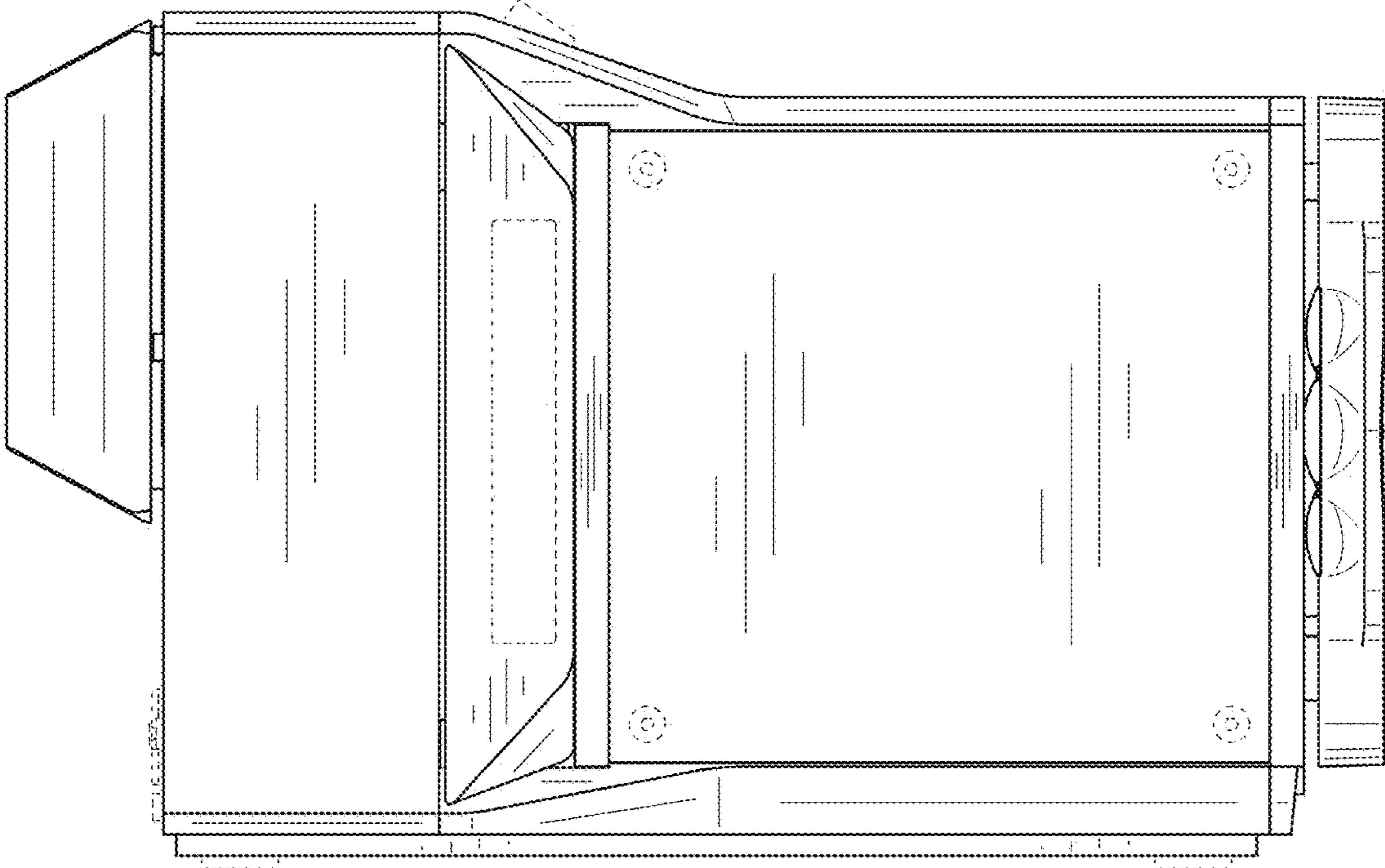

FIG.6

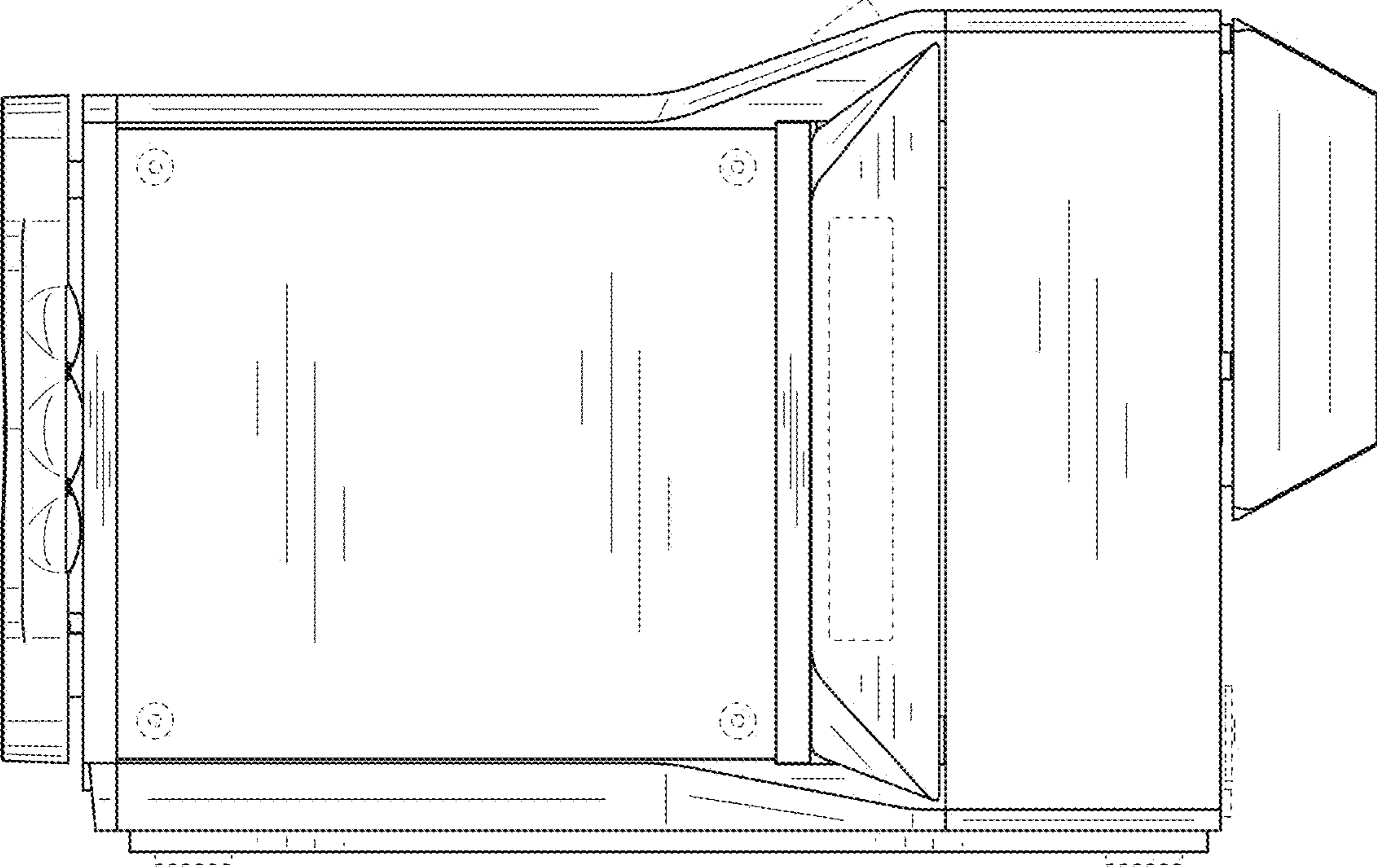



FIG.7

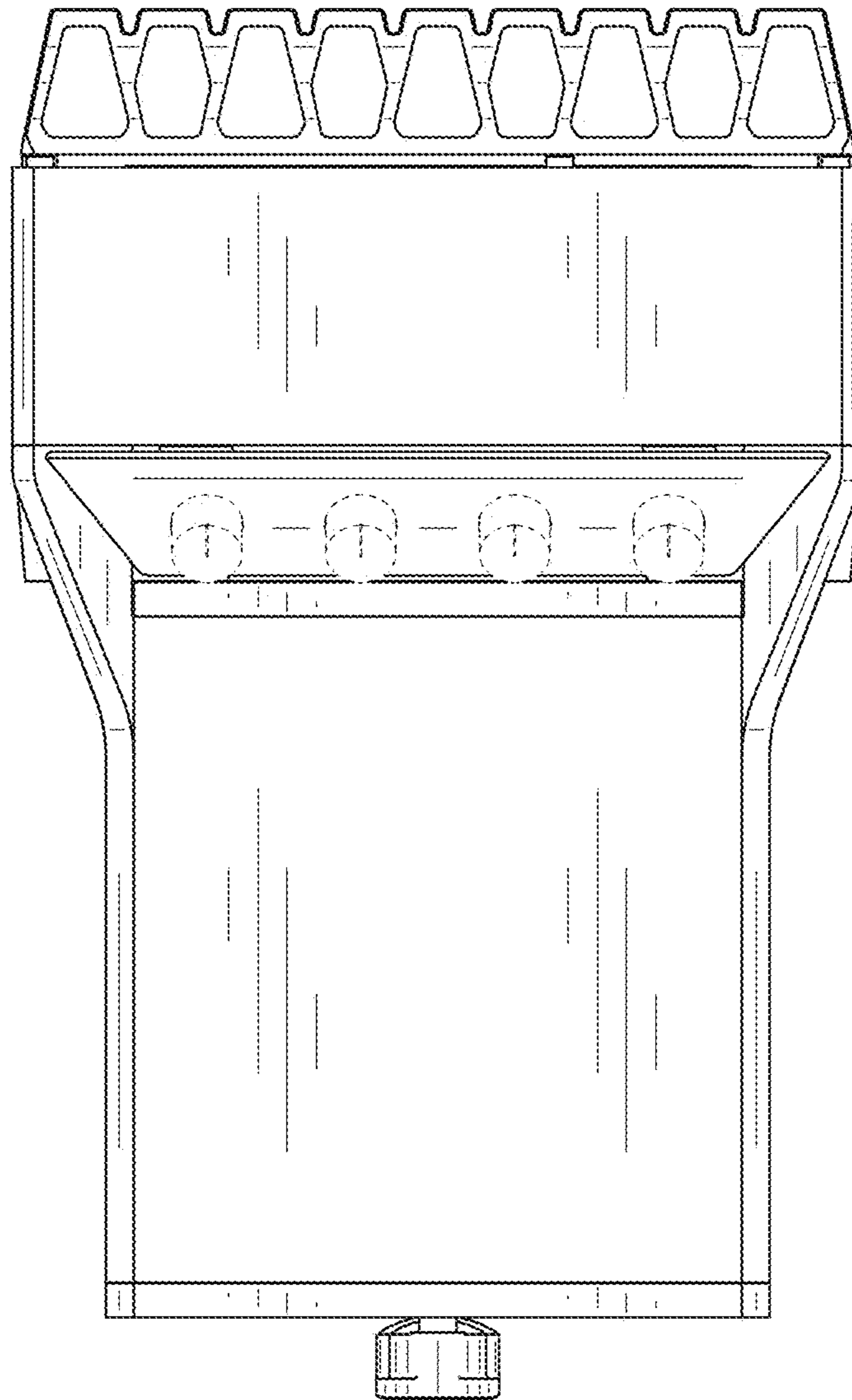

FIG.8

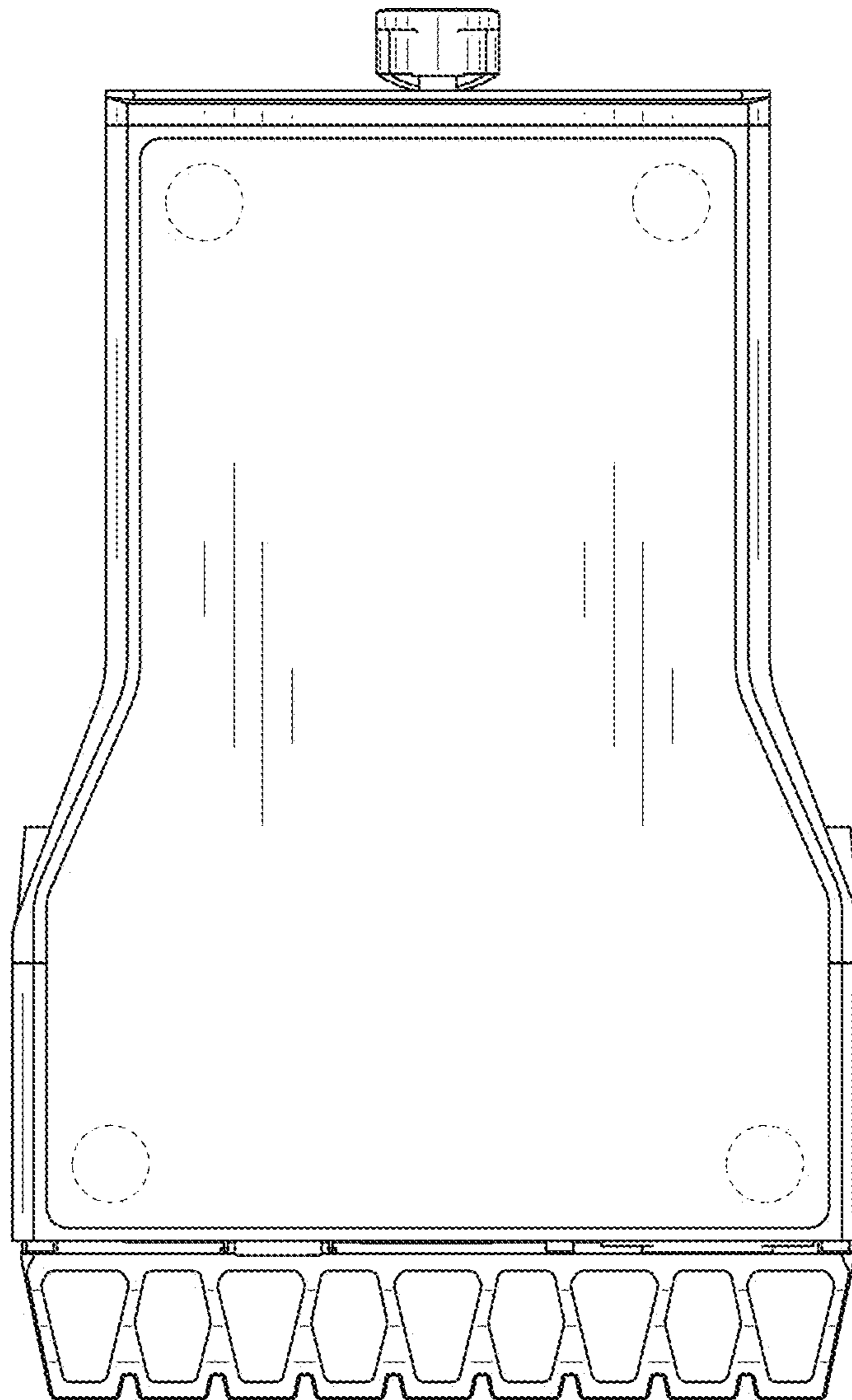

FIG.9

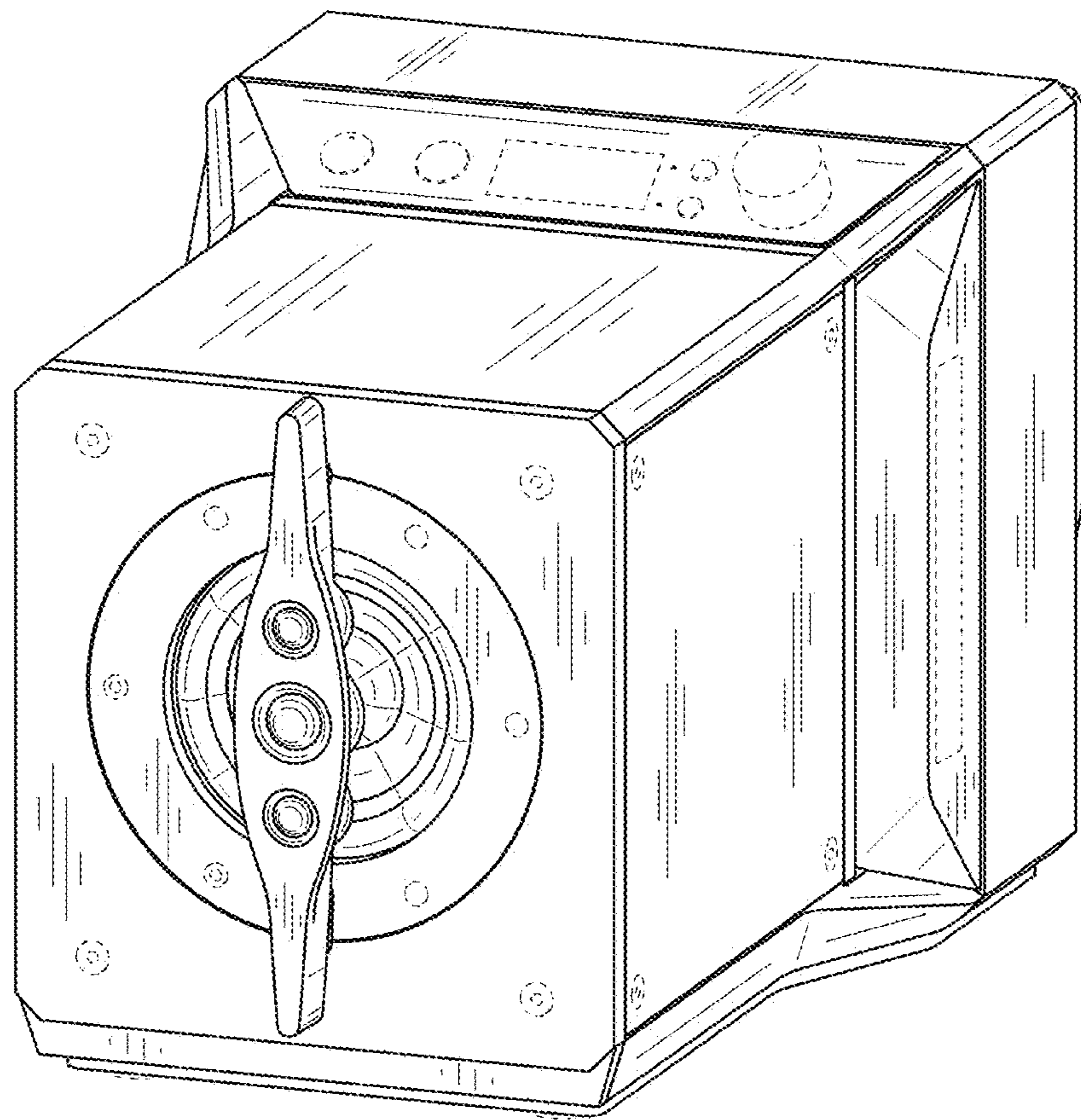

FIG. 10

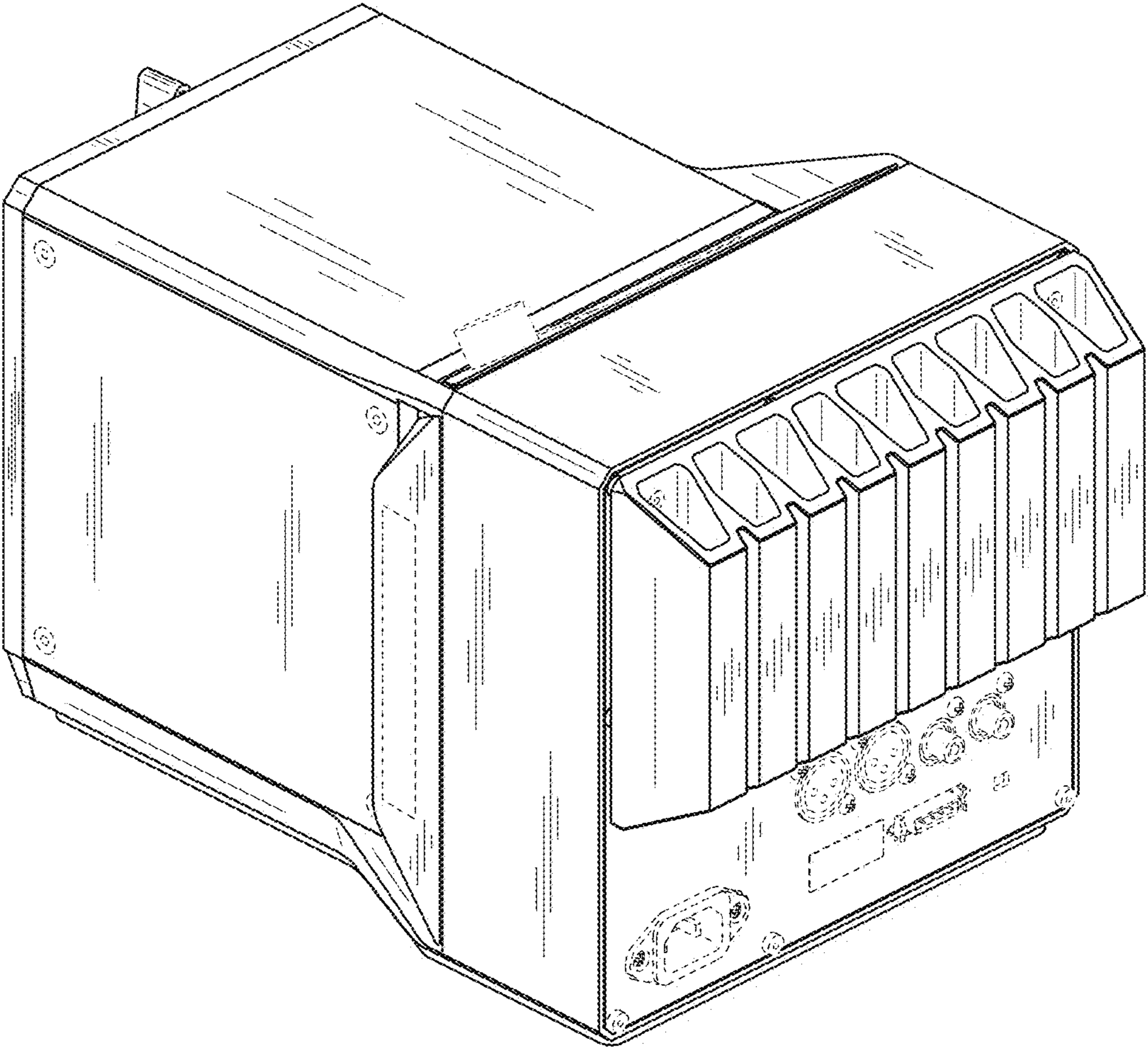

FIG. 11

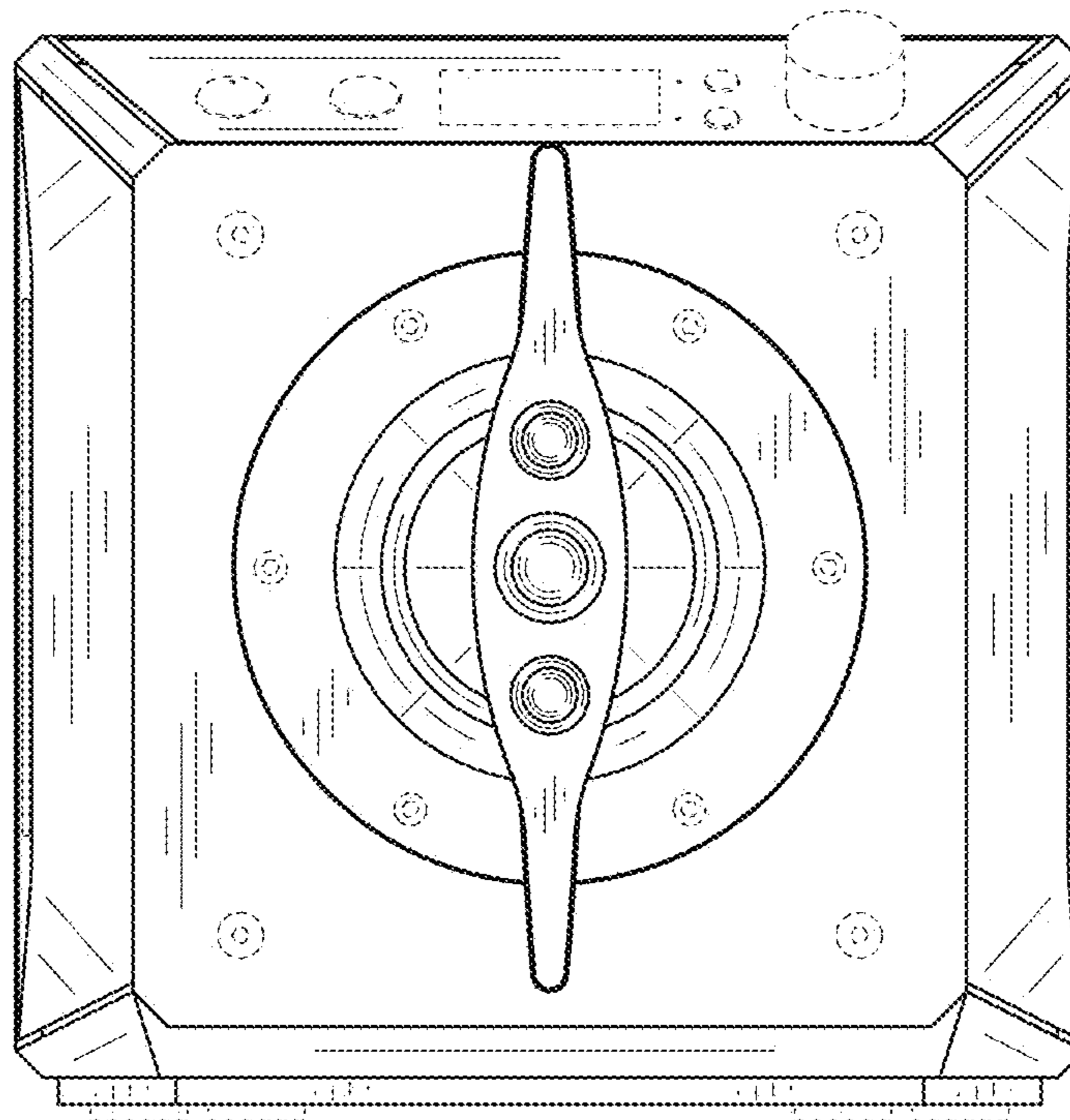

FIG. 12

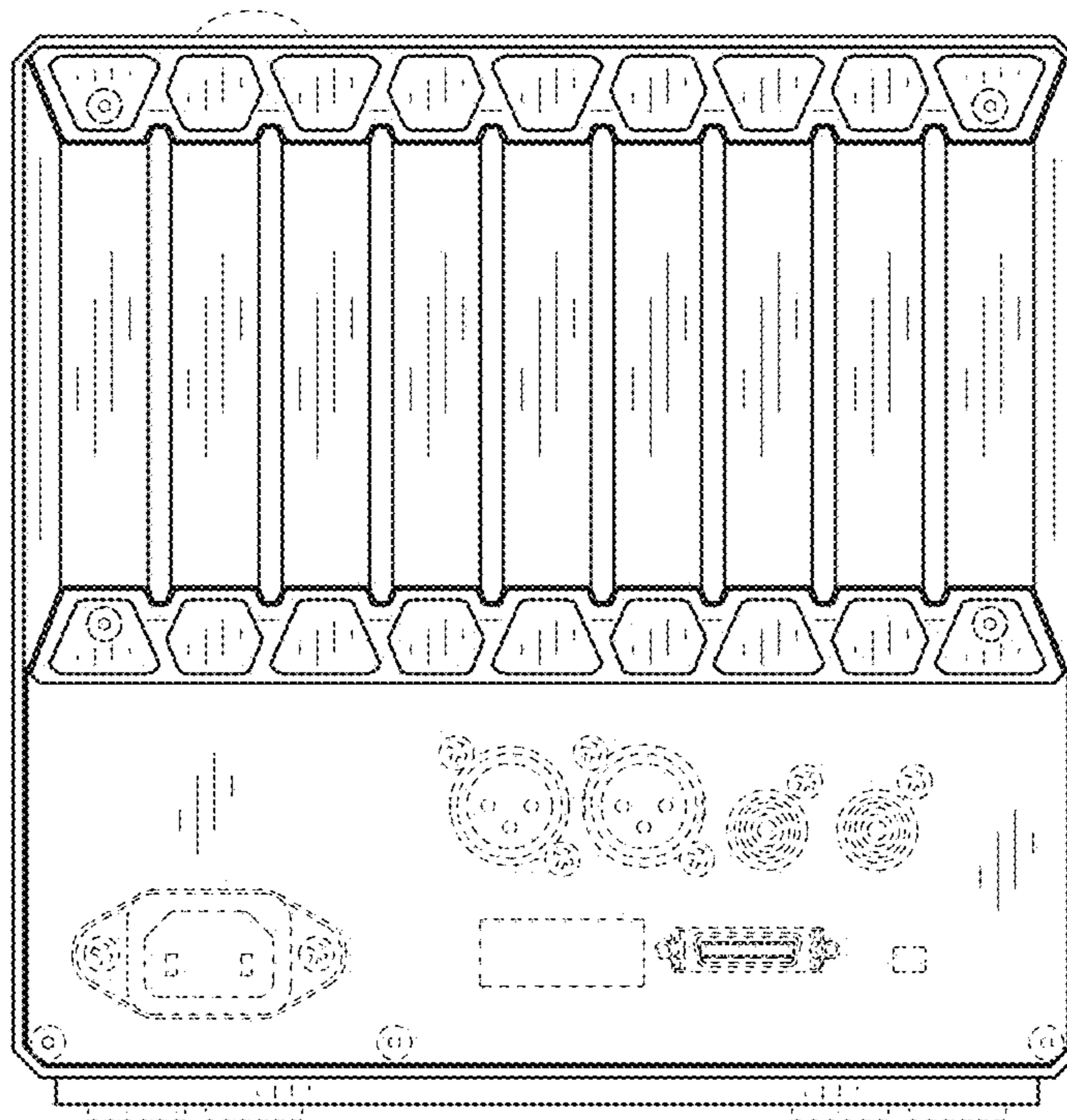

FIG. 13

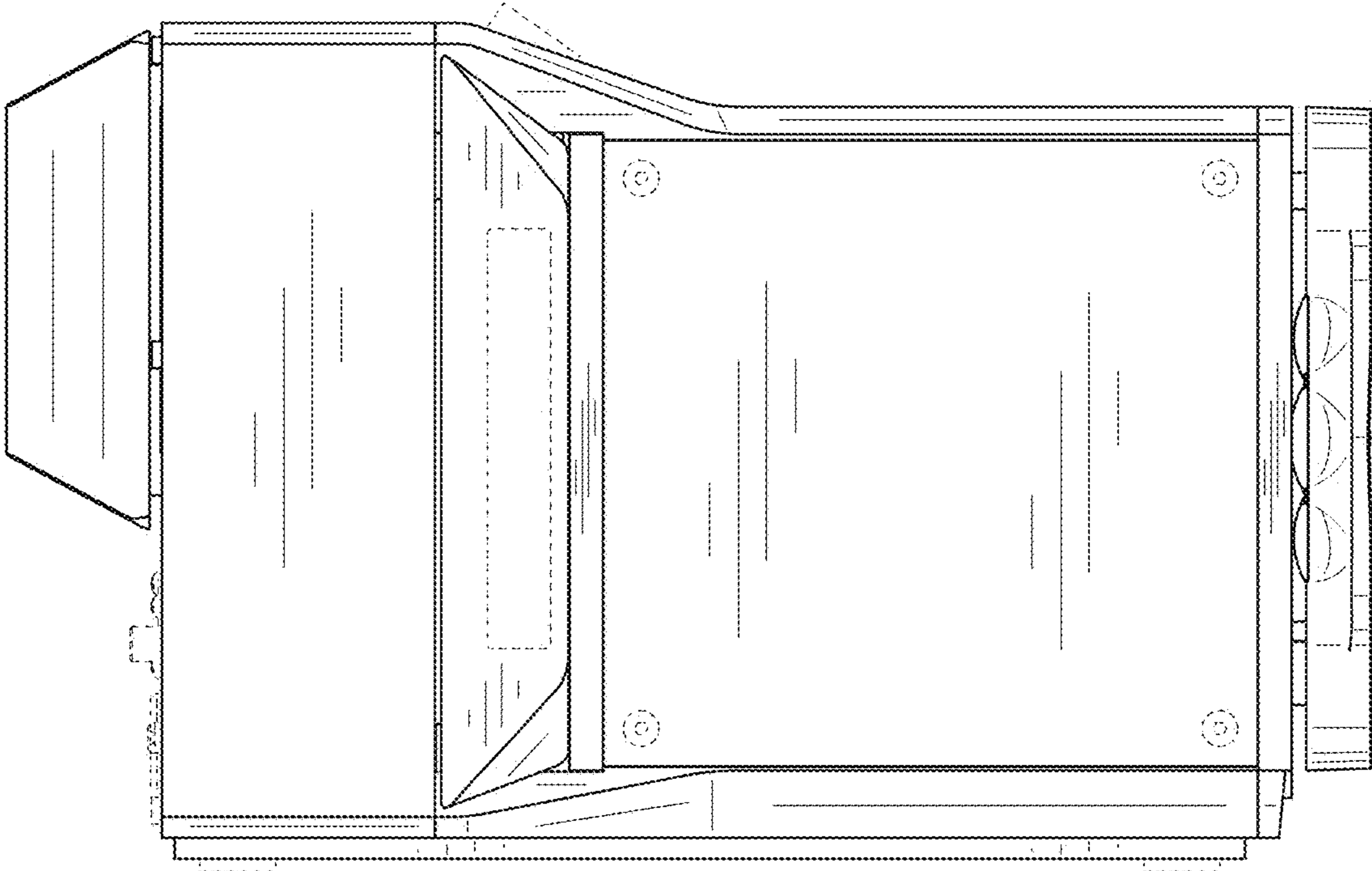

FIG. 14

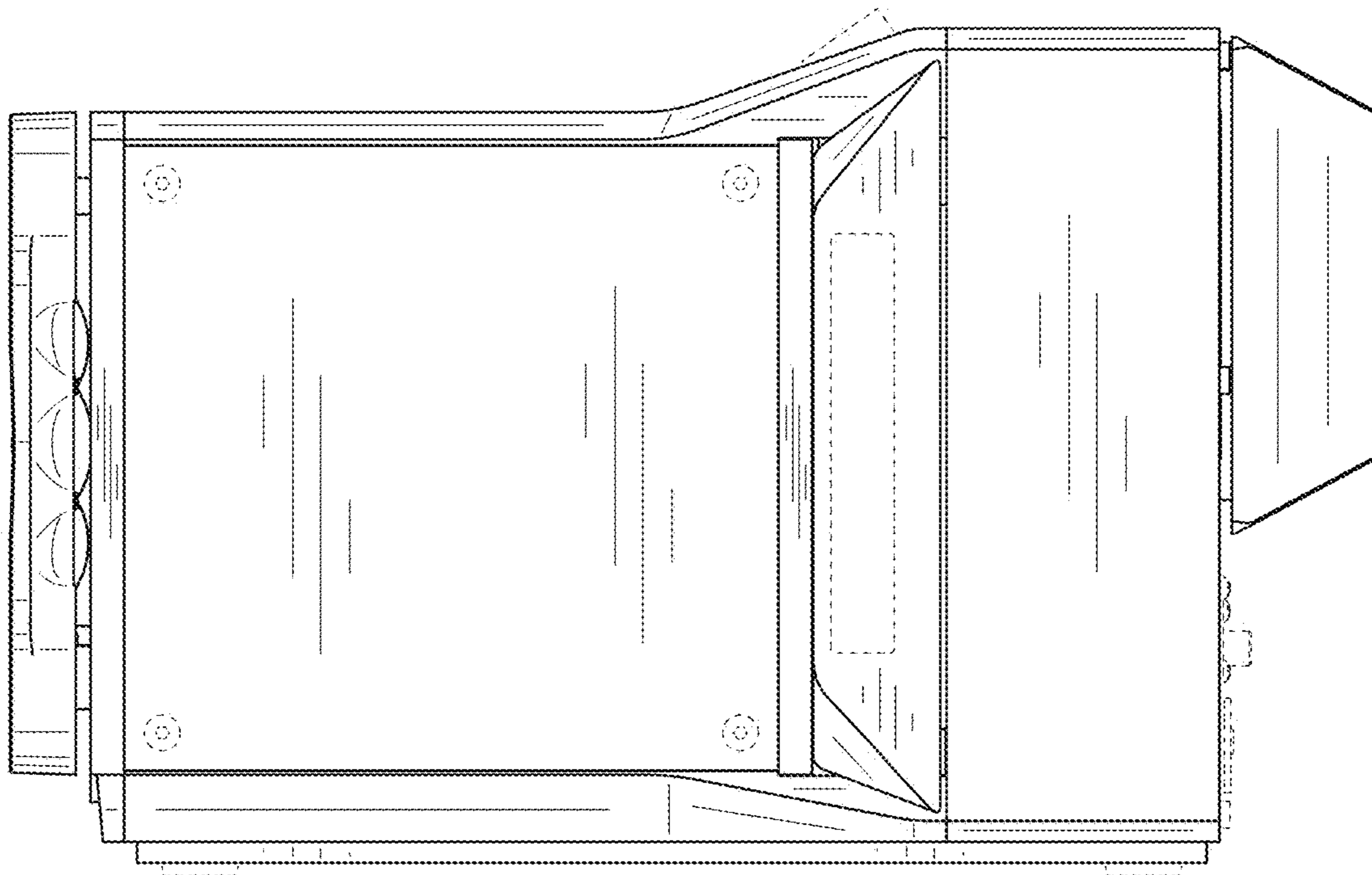



FIG. 15

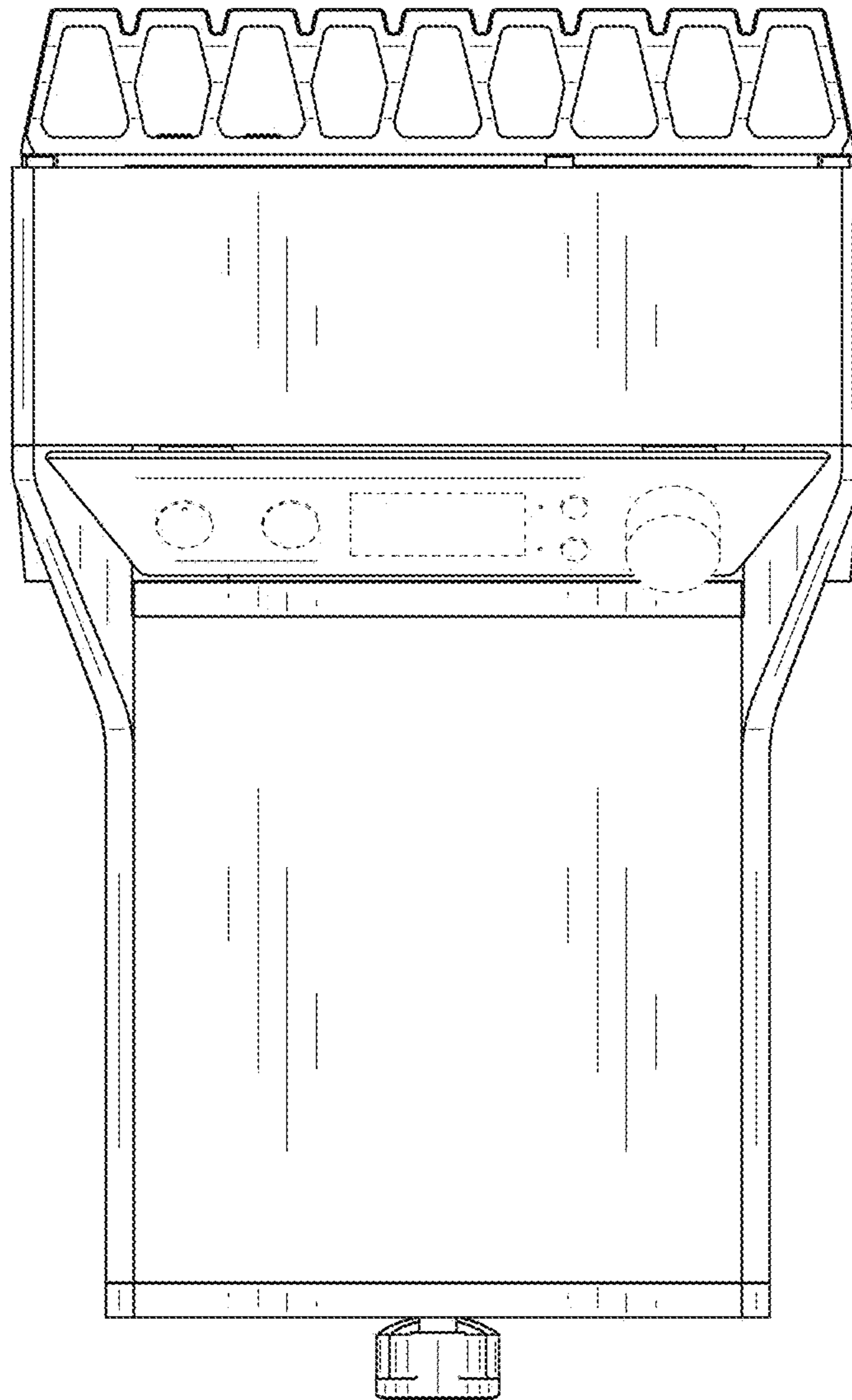

FIG. 16

