



US00D913980S

(12) **United States Design Patent**
Lee et al.

(10) **Patent No.: US D913,980 S**
(45) **Date of Patent: ** Mar. 23, 2021**

(54) **GAS SUPPLY PLATE FOR SEMICONDUCTOR MANUFACTURING APPARATUS**

(71) Applicant: **ASM IP Holding B.V.**, Almere (NL)

(72) Inventors: **Hak Joo Lee**, Gyeonggi-do (KR);
Jeong Jun Woo, Chungcheongnam-do (KR);
Jong Hyun Ahn, Gyeonggi-do (KR);
Yoon Ki Min, Seoul (KR)

(73) Assignee: **ASM IP Holding B.V.**, Almere (NL)

(**) Term: **15 Years**

(21) Appl. No.: **29/726,623**

(22) Filed: **Mar. 4, 2020**

Related U.S. Application Data

(63) Continuation of application No. 29/646,377, filed on May 3, 2018, now Pat. No. Des. 880,437.

(30) **Foreign Application Priority Data**

Feb. 1, 2018 (KR) 30-2018-0005758

(51) **LOC (13) Cl.** **13-03**

(52) **U.S. Cl.**
USPC **D13/182**

(58) **Field of Classification Search**
USPC D13/182; D23/213

(Continued)

(56) **References Cited**

U.S. PATENT DOCUMENTS

D30,036 S 1/1899 Rhind
D31,889 S 11/1899 Gill

(Continued)

FOREIGN PATENT DOCUMENTS

AT 520629 6/2019
CN 1186873 7/1998

(Continued)

OTHER PUBLICATIONS

CNIPA; Office Action dated Jan. 10, 2013 in Application No. 201080015699.9.

(Continued)

Primary Examiner — Elizabeth J Oswecki

(74) *Attorney, Agent, or Firm* — Snell & Wilmer L.L.P.

(57) **CLAIM**

The ornamental design for a gas supply plate for semiconductor manufacturing apparatus, as shown and described.

DESCRIPTION

FIG. 1 is a perspective view of a gas supply plate for semiconductor manufacturing apparatus showing our new design;

FIG. 2 is a front elevational view thereof;

FIG. 3 is a rear elevational view thereof;

FIG. 4 is a left side elevational view thereof;

FIG. 5 is a right side elevational view thereof;

FIG. 6 is a top plan view thereof;

FIG. 7 is an enlarged view of the portion labeled “FIG. 7” indicated in FIG. 6;

FIG. 8 is a bottom plan view of the gas supply plate for semiconductor manufacturing apparatus of FIG. 1;

FIG. 9 is an enlarged view of the portion labeled “FIG. 9” indicated in FIG. 8; and,

FIG. 10 is a cross-sectional view, taken along a line 10-10 of FIG. 9.

The dashed-dot lines in FIGS. 6-9 represent the boundary lines of an enlarged portion of the gas supply plate for semiconductor manufacturing apparatus. The even dashed lines that define the circle in FIGS. 1,6,7,8 and 9 and the even dashed lines that define the outer edge of the cross sectional view in FIG. 10 form no part of the claimed design.

1 Claim, 6 Drawing Sheets

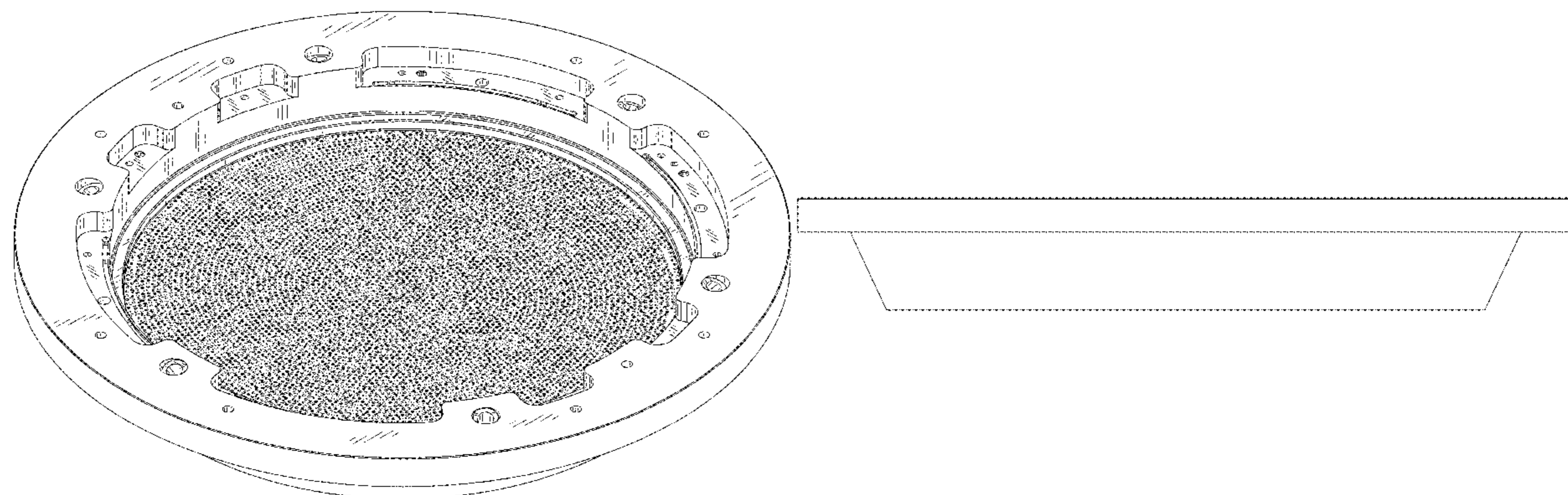

(58) **Field of Classification Search**

CPC H01J 37/32623; H01J 37/32633; H01J 37/32642; H01J 37/32; H01J 37/3244; H01J 37/32449; H01L 21/67; H01L 21/67011; H01L 21/67063; H01L 21/67069; H01L 21/6708; H01L 21/68098; H01L 21/67109; H01L 21/6875; H01L 21/68714; F27B 15/00; F27B 15/006; F27B 15/10; C30B 31/10; C30B 31/16; C30B 31/165; C30B 31/14; C30B 33/12; F27D 5/00; F27D 5/0037; F27D 7/02; F27D 7/00; F27D 7/023; G21D 9/673; G21D 9/675; G21D 9/677; G21D 9/42; G21D 9/54; G21D 9/0025; B21C 47/26; C23C 16/4412; C23C 16/44; C23C 16/4404; C23C 16/4405; C23C 16/4408; C23C 16/455; C23C 16/45517; C23C 16/45519; C23C 16/45521; C23C 16/45559; C23C 16/45563; C23C 16/45565; C23C 16/45568; C23C 16/4557; C23C 16/45587; C23C 16/458; C23C 16/4581; C23C 16/4582; C23C 16/4584; C23C 16/46; C23C 16/466

See application file for complete search history.

4,164,959 A 8/1979 Wurzburger
 4,176,630 A 12/1979 Elmer
 4,181,330 A 1/1980 Kojima
 4,194,536 A 3/1980 Stine et al.
 4,217,463 A 8/1980 Swearingen
 4,229,064 A 10/1980 Vetter et al.
 4,234,449 A 11/1980 Wolson et al.
 4,322,592 A 3/1982 Martin
 4,333,735 A 6/1982 Hardy
 4,355,912 A 10/1982 Haak
 4,389,973 A 6/1983 Suntola et al.
 D269,850 S 7/1983 Preisler et al.
 4,393,013 A 7/1983 McMenamin
 4,401,507 A 8/1983 Engle
 4,414,492 A 11/1983 Hanlet
 4,436,674 A 3/1984 McMenamin
 4,444,990 A 4/1984 Villar
 D274,122 S 6/1984 Stahel et al.
 4,454,370 A 6/1984 Voznick
 4,455,193 A 6/1984 Jeuch et al.
 4,466,766 A 8/1984 Geren et al.
 4,479,831 A 10/1984 Sandow
 4,484,061 A 11/1984 Zelinka et al.
 4,499,354 A 2/1985 Hill et al.
 4,512,113 A 4/1985 Budinger
 4,512,841 A 4/1985 Cunningham et al.
 4,527,005 A 7/1985 McKelvey et al.
 4,537,001 A 8/1985 Uppstrom
 4,548,688 A 10/1985 Mathews
 4,570,328 A 2/1986 Price et al.
 4,575,636 A 3/1986 Caprari
 4,578,560 A 3/1986 Tanaka et al.
 4,579,080 A 4/1986 Martin et al.
 4,579,378 A 4/1986 Snyders
 4,579,623 A 4/1986 Suzuki et al.
 4,581,520 A 4/1986 Vu et al.
 4,590,326 A 5/1986 Woldy
 4,611,966 A 9/1986 Johnson
 4,620,998 A 11/1986 Lalvani
 D288,556 S 3/1987 Wallgren
 4,653,541 A 3/1987 Oehlschlaeger et al.
 4,654,226 A 3/1987 Jackson et al.
 4,664,769 A 5/1987 Cuomo et al.
 4,681,134 A 7/1987 Paris
 4,693,211 A 9/1987 Ogami et al.
 4,718,637 A 1/1988 Contin
 4,721,533 A 1/1988 Phillippi et al.
 4,722,298 A 2/1988 Rubin et al.
 4,724,272 A 2/1988 Raniere et al.
 4,735,259 A 4/1988 Vincent
 4,749,416 A 6/1988 Greenspan
 4,750,520 A 6/1988 Heim et al.
 4,753,192 A 6/1988 Goldsmith et al.
 4,753,856 A 6/1988 Haluska et al.
 4,756,794 A 7/1988 Yoder
 4,771,015 A 9/1988 Kanai
 4,780,169 A 10/1988 Stark et al.
 4,789,294 A 12/1988 Sato et al.
 4,790,258 A 12/1988 Drage et al.
 4,808,387 A 2/1989 Datta et al.
 4,812,201 A 3/1989 Sakai et al.
 4,821,674 A 4/1989 deBoer et al.
 4,827,430 A 5/1989 Aid et al.
 4,828,224 A 5/1989 Crabb et al.
 4,830,515 A 5/1989 Cortes
 4,837,113 A 6/1989 Luttmmer et al.
 4,837,185 A 6/1989 Yau et al.
 4,854,263 A 8/1989 Chang et al.
 4,854,266 A 8/1989 Simson et al.
 4,857,137 A 8/1989 Tachi et al.
 4,857,382 A 8/1989 Liu et al.
 4,858,557 A 8/1989 Pozzetti et al.
 4,871,523 A 10/1989 Datta et al.
 4,882,199 A 11/1989 Sadoway et al.
 4,916,091 A 4/1990 Freeman et al.
 4,934,831 A 6/1990 Volbrecht
 D309,702 S 8/1990 Hall
 4,949,848 A 8/1990 Kos
 D311,126 S 10/1990 Crowley

(56) **References Cited**

U.S. PATENT DOCUMENTS

D56,051 S 8/1920 Cohn
 2,059,480 A 11/1936 Obermaier
 2,161,626 A 6/1939 Loughner et al.
 2,266,416 A 12/1941 Duclos
 2,280,778 A 4/1942 Andersen
 D142,841 S * 11/1945 Algodt D23/213
 2,410,420 A 11/1946 Bennett
 2,563,931 A 8/1951 Harrison
 2,660,061 A 11/1953 Lewis
 2,745,640 A 5/1956 Cushman
 2,990,045 A 6/1961 Root
 3,038,951 A 6/1962 Mead
 3,089,507 A 5/1963 Drake et al.
 3,094,396 A 6/1963 Flugge et al.
 3,232,437 A 2/1966 Hultgren
 3,263,502 A 8/1966 Springfield
 3,332,286 A 7/1967 Strong
 3,410,349 A 11/1968 Troutman
 3,588,192 A 6/1971 Drutchas et al.
 3,647,387 A 3/1972 Benson
 3,647,716 A 3/1972 Koches
 3,713,899 A 1/1973 Sebestyen
 3,718,429 A 2/1973 Williamson
 3,796,182 A 3/1974 Rosler
 3,833,492 A 9/1974 Bollyky
 3,854,443 A 12/1974 Baerg
 3,862,397 A 1/1975 Anderson et al.
 3,867,205 A 2/1975 Schley
 3,885,504 A 5/1975 Baermann
 3,887,790 A 6/1975 Ferguson
 3,904,371 A 9/1975 Neti
 3,913,058 A 10/1975 Nishio et al.
 3,913,617 A 10/1975 van Laar
 3,947,685 A 3/1976 Meinel
 3,960,559 A 6/1976 Suzuki
 3,997,638 A 12/1976 Manning et al.
 4,048,110 A 9/1977 Vanderspurt
 4,054,071 A 10/1977 Patejak
 4,058,430 A 11/1977 Suntola et al.
 4,093,491 A 6/1978 Whelpton et al.
 D249,341 S 9/1978 Mertz
 4,126,027 A 11/1978 Smith et al.
 4,134,425 A 1/1979 Gussefeld et al.
 4,145,699 A 3/1979 Hu et al.
 4,152,760 A 5/1979 Freitas et al.

(56)

References Cited

U.S. PATENT DOCUMENTS

4,976,996 A	12/1990	Monkowski et al.	5,305,417 A	4/1994	Najm et al.
4,978,567 A	12/1990	Miller	5,306,666 A	4/1994	Izumi
4,984,904 A	1/1991	Nakano et al.	5,306,946 A	4/1994	Yamamoto
4,985,114 A	1/1991	Okudaira	5,308,650 A	5/1994	Krummel et al.
4,986,215 A	1/1991	Yamada	5,310,456 A	5/1994	Kadomura
4,987,102 A	1/1991	Nguyen et al.	5,313,061 A	5/1994	Drew et al.
4,987,856 A	1/1991	Hey	5,314,570 A	5/1994	Ikegaya et al.
4,989,992 A	2/1991	Piai	5,315,092 A	5/1994	Takahashi et al.
4,991,614 A	2/1991	Hammel	5,320,218 A	6/1994	Yamashita et al.
5,002,632 A	3/1991	Loewenstein et al.	5,326,427 A	7/1994	Jerbic
5,013,691 A	5/1991	Lory et al.	5,328,810 A	7/1994	Lowrey et al.
5,027,746 A	7/1991	Frijlink	5,336,327 A	8/1994	Lee
5,028,366 A	7/1991	Harakal et al.	5,338,362 A	8/1994	Imahashi
D320,148 S	9/1991	Andrews	5,346,961 A	9/1994	Shaw et al.
5,049,029 A	9/1991	Mitsui et al.	5,348,774 A	9/1994	Golecki et al.
5,053,247 A	10/1991	Moore	5,350,480 A	9/1994	Gray
5,057,436 A	10/1991	Ball	5,354,580 A	10/1994	Goela et al.
5,060,322 A	10/1991	Delepine	5,356,478 A	10/1994	Chen et al.
5,061,083 A	10/1991	Grimm et al.	5,356,672 A	10/1994	Schmitt et al.
5,062,386 A	11/1991	Christensen	5,360,269 A	11/1994	Ogawa et al.
5,064,337 A	11/1991	Asakawa et al.	5,364,667 A	11/1994	Rhieu
5,065,698 A	11/1991	Koike	D353,452 S	12/1994	Groenhoff
5,069,591 A	12/1991	Kinoshita	5,374,315 A	12/1994	Deboer et al.
5,071,258 A	12/1991	Usher et al.	D354,898 S	1/1995	Nagy
5,074,017 A	12/1991	Toya et al.	5,380,367 A	1/1995	Bertone
5,082,517 A	1/1992	Moslehi	5,382,311 A	1/1995	Ishikawa et al.
5,084,126 A	1/1992	McKee	5,388,945 A	2/1995	Garric et al.
5,088,444 A	2/1992	Ohmine et al.	5,397,395 A	3/1995	Sano et al.
5,098,638 A	3/1992	Sawada	5,403,630 A	4/1995	Matsui et al.
5,098,865 A	3/1992	Machado	5,404,082 A	4/1995	Hernandez et al.
5,104,514 A	4/1992	Quartarone	5,407,449 A	4/1995	Zinger
5,107,170 A	4/1992	Ishikawa et al.	5,413,813 A	5/1995	Cruse et al.
5,108,192 A	4/1992	Mailliet et al.	5,414,221 A	5/1995	Gardner
5,110,407 A	5/1992	Ono et al.	5,415,753 A	5/1995	Hurwitt et al.
5,114,683 A	5/1992	Hirase	5,418,382 A	5/1995	Blackwood et al.
5,116,018 A	5/1992	Friemoth et al.	5,421,893 A	6/1995	Perlov
D327,534 S	6/1992	Manville	5,422,139 A	6/1995	Fischer
5,119,760 A	6/1992	McMillan et al.	5,423,942 A	6/1995	Robbins et al.
5,130,003 A	7/1992	Conrad	5,426,137 A	6/1995	Allen
5,137,286 A	8/1992	Whitford	5,430,011 A	7/1995	Tanaka et al.
5,151,296 A	9/1992	Tokunaga	5,431,734 A	7/1995	Chapple-Sokol et al.
5,154,301 A	10/1992	Kos	5,444,217 A	8/1995	Moore
5,158,128 A	10/1992	Inoue et al.	5,447,294 A	9/1995	Sakata et al.
D330,900 S	11/1992	Wakegijig	5,453,124 A	9/1995	Moslehi et al.
5,167,716 A	12/1992	Boitnott et al.	D363,464 S *	10/1995	Fukasawa D13/182
5,176,451 A	1/1993	Sasada	5,456,207 A	10/1995	Gedridge et al.
5,178,682 A	1/1993	Tsukamoto et al.	5,461,214 A	10/1995	Peck et al.
5,181,779 A	1/1993	Shia et al.	5,462,899 A	10/1995	Ikeda
5,183,511 A	2/1993	Yamazaki et al.	5,463,176 A	10/1995	Eckert
5,192,717 A	3/1993	Kawakami	5,474,612 A	12/1995	Sato et al.
5,194,401 A	3/1993	Adams et al.	5,480,818 A	1/1996	Matsumoto et al.
5,199,603 A	4/1993	Prescott	5,482,559 A	1/1996	Imai et al.
5,213,650 A	5/1993	Wang et al.	5,484,484 A	1/1996	Yamaga et al.
5,221,556 A	6/1993	Hawkins et al.	5,494,439 A	2/1996	Goldstein et al.
5,225,366 A	7/1993	Yoder	5,494,494 A	2/1996	Mizuno et al.
5,226,383 A	7/1993	Bhat	5,496,408 A	3/1996	Motoda et al.
5,228,114 A	7/1993	Suzuki	5,501,740 A	3/1996	Besen et al.
5,232,508 A	8/1993	Arena et al.	5,503,875 A	4/1996	Imai et al.
5,242,539 A	9/1993	Kumihashi et al.	5,504,042 A	4/1996	Cho et al.
5,243,195 A	9/1993	Nishi	5,510,277 A	4/1996	Cunningham et al.
5,243,202 A	9/1993	Mori et al.	5,514,439 A	5/1996	Sibley
5,246,218 A	9/1993	Yap et al.	5,518,549 A	5/1996	Hellwig
5,246,500 A	9/1993	Samata et al.	5,520,743 A	5/1996	Takahashi et al.
5,259,881 A	11/1993	Edwards et al.	5,523,616 A	6/1996	Yasuhide
5,266,526 A	11/1993	Aoyama	5,527,111 A	6/1996	Lysen et al.
5,271,967 A	12/1993	Kramer et al.	5,527,417 A	6/1996	Iida et al.
5,273,609 A	12/1993	Moslehi	5,531,218 A	7/1996	Krebs
5,277,932 A	1/1994	Spencer	5,531,835 A	7/1996	Fodor et al.
5,278,494 A	1/1994	Obigane	5,540,898 A	7/1996	Davidson
5,279,886 A	1/1994	Kawai et al.	5,558,717 A	9/1996	Zhao et al.
5,279,986 A	1/1994	Maloney et al.	5,559,046 A	9/1996	Oishi et al.
5,281,274 A	1/1994	Yoder	5,562,947 A	10/1996	White et al.
5,284,519 A	2/1994	Gadgil	5,574,247 A	11/1996	Nishitani et al.
5,288,684 A	2/1994	Yamazaki et al.	5,576,629 A	11/1996	Turner
5,294,778 A	3/1994	Carman et al.	5,577,331 A	11/1996	Suzuki
			5,583,736 A	12/1996	Anderson et al.
			5,586,585 A	12/1996	Bonora et al.
			5,589,002 A	12/1996	Su
			5,589,110 A	12/1996	Motoda et al.

(56)

References Cited

U.S. PATENT DOCUMENTS

5,595,606 A	1/1997	Fujikawa et al.	5,855,680 A	1/1999	Soininen et al.
5,601,641 A	2/1997	Stephens	5,855,681 A	1/1999	Maydan et al.
5,602,060 A	2/1997	Kobayashi et al.	5,857,777 A	1/1999	Schuh
5,604,410 A	2/1997	Vollkommer et al.	5,863,123 A	1/1999	Lee et al.
5,616,264 A	4/1997	Nishi et al.	5,865,205 A	2/1999	Wilmer
5,616,947 A	4/1997	Tamura	5,866,795 A	2/1999	Wang et al.
5,621,982 A	4/1997	Yamashita	5,872,065 A	2/1999	Sivaramakrishnan
5,632,919 A	5/1997	MacCracken et al.	5,873,942 A	2/1999	Park
D380,527 S	7/1997	Velez	5,877,095 A	3/1999	Tamura et al.
5,653,807 A	8/1997	Crumbaker	5,879,128 A	3/1999	Tietz et al.
5,656,093 A	8/1997	Burkhart et al.	5,879,459 A	3/1999	Gadgil et al.
5,662,470 A	9/1997	Huussen et al.	5,880,980 A	3/1999	Rothacher et al.
5,663,899 A	9/1997	Zvonar et al.	5,882,165 A	3/1999	Maydan et al.
5,665,608 A	9/1997	Chapple-Sokol et al.	5,884,640 A	3/1999	Fishkin et al.
5,667,592 A	9/1997	Boitnott et al.	5,893,741 A	4/1999	Huang
5,679,215 A	10/1997	Barnes et al.	D409,894 S	5/1999	McClurg
5,681,779 A	10/1997	Pasch et al.	5,904,170 A	5/1999	Harvey et al.
D386,076 S	11/1997	Moore	D411,516 S *	6/1999	Imafuku D13/182
5,683,517 A	11/1997	Shan	5,908,672 A	6/1999	Ryu
5,685,912 A	11/1997	Nishizaka	5,915,562 A	6/1999	Nyseth et al.
5,685,914 A	11/1997	Hills et al.	5,916,365 A	6/1999	Sherman
5,695,567 A	12/1997	Kordina	D412,270 S	7/1999	Fredrickson
5,697,706 A	12/1997	Ciaravino et al.	5,920,798 A	7/1999	Higuchi et al.
5,698,036 A	12/1997	Ishii et al.	5,928,426 A	7/1999	Aitchison
5,700,729 A	12/1997	Lee et al.	D412,512 S	8/1999	Boisvert
5,708,825 A	1/1998	Sotomayor	5,937,323 A	8/1999	Orczyk et al.
5,709,745 A	1/1998	Larkin et al.	5,939,886 A	8/1999	Turner et al.
5,711,811 A	1/1998	Suntola et al.	5,947,718 A	9/1999	Weaver
5,716,133 A	2/1998	Hosokawa et al.	5,950,327 A	9/1999	Peterson et al.
5,718,574 A	2/1998	Shimazu	5,950,925 A	9/1999	Fukunaga et al.
5,720,927 A	2/1998	Cripe et al.	5,954,375 A	9/1999	Trickle et al.
D392,855 S	3/1998	Pillow	5,961,775 A	10/1999	Fujimura
5,724,748 A	3/1998	Brooks	5,968,275 A	10/1999	Lee et al.
5,728,223 A	3/1998	Murakarni et al.	5,970,621 A	10/1999	Bazydola
5,728,425 A	3/1998	Ebe et al.	5,972,196 A	10/1999	Murphy et al.
5,730,801 A	3/1998	Tepman et al.	5,975,492 A	11/1999	Brenes
5,730,802 A	3/1998	Ishizumi et al.	5,979,506 A	11/1999	Aarseth
5,732,744 A	3/1998	Barr et al.	5,982,931 A	11/1999	Ishimaru
5,736,314 A	4/1998	Hayes et al.	5,984,391 A	11/1999	Vanderpot et al.
5,753,835 A	5/1998	Gustin	5,987,480 A	11/1999	Donohue et al.
5,759,281 A	6/1998	Gurary et al.	5,989,342 A	11/1999	Ikeda et al.
5,761,328 A	6/1998	Solberg et al.	5,992,453 A	11/1999	Zimmer
5,766,365 A	6/1998	Umutoy et al.	5,997,588 A	12/1999	Goodwin
5,768,125 A	6/1998	Zinger et al.	5,997,768 A	12/1999	Scully
5,775,889 A	7/1998	Kobayashi et al.	5,998,870 A	12/1999	Lee et al.
5,777,838 A	7/1998	Tamagawa et al.	6,000,732 A	12/1999	Scheler et al.
5,779,203 A	7/1998	Edlinger	6,001,183 A	12/1999	Gurary et al.
5,781,693 A	7/1998	Ballance et al.	6,001,267 A	12/1999	Van Os et al.
5,782,979 A	7/1998	Kaneno	6,004,204 A	12/1999	Luxton et al.
5,791,782 A	8/1998	Wooten et al.	D419,652 S	1/2000	Hall et al.
5,792,272 A	8/1998	Van Os et al.	6,013,553 A	1/2000	Wallace
5,796,074 A	8/1998	Edelstein et al.	6,013,920 A	1/2000	Gordon et al.
5,801,104 A	9/1998	Schuegraf et al.	6,015,459 A	1/2000	Jamison et al.
5,801,945 A	9/1998	Commer	6,015,465 A	1/2000	Kholodenko et al.
5,806,980 A	9/1998	Berrian	6,017,779 A	1/2000	Miyasaka
5,813,851 A	9/1998	Nakao	6,017,818 A	1/2000	Lu
5,818,716 A	10/1998	Chin et al.	6,024,799 A	2/2000	Chen
5,819,092 A	10/1998	Ferguson et al.	6,027,163 A	2/2000	Longenecker et al.
5,819,434 A	10/1998	Herchen et al.	6,035,101 A	3/2000	Sajoto et al.
5,820,685 A	10/1998	Kurihira et al.	6,035,804 A	3/2000	Arami et al.
5,820,686 A	10/1998	Moore	6,042,652 A	3/2000	Hyun
5,827,420 A	10/1998	Shirazi et al.	6,044,860 A	4/2000	Neu
5,827,435 A	10/1998	Samukawa	6,045,260 A	4/2000	Schwartz et al.
5,827,757 A	10/1998	Robinson, Jr. et al.	6,048,154 A	4/2000	Wytman
5,836,483 A	11/1998	Disel	6,050,506 A	4/2000	Guo et al.
5,837,058 A	11/1998	Chen et al.	6,053,982 A	4/2000	Halpin et al.
5,837,320 A	11/1998	Hampden-Smith et al.	6,053,983 A	4/2000	Saeki et al.
5,844,683 A	12/1998	Pavloski et al.	6,054,013 A	4/2000	Collins et al.
5,846,332 A	12/1998	Zhao et al.	6,054,678 A	4/2000	Miyazaki
5,851,294 A	12/1998	Young et al.	6,060,691 A	5/2000	Minami et al.
5,852,445 A	12/1998	Yoshikawa et al.	6,060,721 A	5/2000	Huang
5,852,879 A	12/1998	Schumaier	6,063,196 A	5/2000	Li et al.
5,853,484 A	12/1998	Jeong	6,068,441 A	5/2000	Raaijmakers et al.
D404,370 S	1/1999	Kimura	6,072,163 A	6/2000	Armstrong et al.
D404,372 S	1/1999	Ishii	6,073,973 A	6/2000	Boscaljon et al.
			6,074,154 A	6/2000	Ueda et al.
			6,074,443 A	6/2000	Venkatesh
			6,074,514 A	6/2000	Bjorkman et al.
			6,077,027 A	6/2000	Kawamura et al.

(56)

References Cited

U.S. PATENT DOCUMENTS

<p>6,079,356 A 6/2000 Umotoy et al. 6,079,927 A 6/2000 Muka 6,083,321 A 7/2000 Lei et al. 6,086,677 A 7/2000 Umotoy et al. 6,090,212 A 7/2000 Mahawili 6,091,062 A 7/2000 Pfahnl et al. 6,093,252 A 7/2000 Wengert et al. 6,093,253 A 7/2000 Lofgren 6,095,083 A 8/2000 Rice et al. 6,096,133 A 8/2000 Yuuki et al. 6,096,267 A 8/2000 Kishkovich 6,099,302 A 8/2000 Hong et al. 6,099,649 A 8/2000 Schmitt et al. 6,102,565 A 8/2000 Kita et al. 6,104,011 A 8/2000 Juliano 6,104,401 A 8/2000 Parsons 6,106,625 A 8/2000 Koai et al. 6,106,678 A 8/2000 Shufflebotham 6,119,710 A 9/2000 Brown 6,121,061 A 9/2000 Van Bilsen et al. 6,121,158 A 9/2000 Benchikha et al. 6,122,036 A 9/2000 Yamasaki et al. 6,124,600 A 9/2000 Moroishi et al. 6,125,789 A 10/2000 Gupta et al. 6,126,744 A 10/2000 Hawkins et al. 6,126,848 A 10/2000 Li et al. 6,127,249 A 10/2000 Hu 6,129,044 A 10/2000 Zhao et al. 6,129,546 A 10/2000 Sada 6,134,807 A 10/2000 Komino 6,135,460 A 10/2000 Wise et al. 6,137,240 A 10/2000 Bogdan 6,140,252 A 10/2000 Cho et al. 6,143,079 A 11/2000 Halpin 6,143,082 A 11/2000 McInerney et al. 6,146,463 A 11/2000 Yudovsky et al. 6,148,761 A 11/2000 Majewski et al. 6,151,446 A 11/2000 Hunter et al. 6,152,070 A 11/2000 Fairbairn et al. 6,156,151 A 12/2000 Komino et al. 6,158,941 A 12/2000 Muka et al. 6,160,244 A 12/2000 Ohashi 6,161,500 A 12/2000 Kopacz et al. 6,162,323 A 12/2000 Koshimizu 6,174,809 B1 1/2001 Kang et al. 6,178,918 B1 1/2001 Van Os et al. 6,180,979 B1 1/2001 Hofman et al. 6,182,603 B1 2/2001 Shang et al. 6,183,564 B1 2/2001 Reynolds et al. 6,187,672 B1 2/2001 Zhao et al. 6,187,691 B1 2/2001 Fukuda 6,190,037 B1 2/2001 Das et al. 6,190,113 B1 2/2001 Bui et al. 6,190,634 B1 2/2001 Lieber et al. 6,191,399 B1 2/2001 Van Bilsen 6,194,037 B1 2/2001 Terasaki et al. 6,201,999 B1 3/2001 Jevtic 6,203,613 B1 3/2001 Gates et al. 6,203,618 B1 3/2001 Hashizume et al. 6,207,932 B1 3/2001 Yoo 6,207,936 B1 3/2001 de Waard 6,212,789 B1 4/2001 Kato 6,214,122 B1 4/2001 Thompson 6,217,658 B1 4/2001 Orczyk et al. 6,218,288 B1 4/2001 Li et al. 6,225,020 B1 5/2001 Jung et al. 6,225,602 B1 5/2001 Buijze et al. 6,231,290 B1 5/2001 Kikuchi et al. 6,235,858 B1 5/2001 Swarup et al. 6,238,734 B1 5/2001 Senzaki et al. 6,241,822 B1 6/2001 Ide 6,242,359 B1 6/2001 Misra 6,243,654 B1 6/2001 Johnson et al. 6,245,665 B1 6/2001 Yokoyama 6,247,245 B1 6/2001 Ishii</p>	<p>6,250,250 B1 6/2001 Maishev et al. 6,257,758 B1 7/2001 Culbertson 6,261,648 B1 7/2001 Akiba et al. 6,264,467 B1 7/2001 Lue et al. 6,265,311 B1 7/2001 Hautala et al. 6,271,148 B1 8/2001 Kao 6,274,496 B1 8/2001 Leusink et al. 6,274,878 B1 8/2001 Li et al. 6,281,098 B1 8/2001 Wang 6,281,141 B1 8/2001 Das et al. 6,284,050 B1 9/2001 Shi et al. 6,284,149 B1 9/2001 Li et al. 6,287,965 B1 9/2001 Kang et al. 6,287,988 B1 9/2001 Nagamine et al. 6,293,700 B1 9/2001 Lund et al. D449,873 S 10/2001 Bronson 6,296,710 B1 10/2001 Allen et al. 6,296,711 B1 10/2001 Loan et al. 6,296,909 B1 10/2001 Spitsberg 6,299,133 B2 10/2001 Waragai et al. 6,302,964 B1 10/2001 Umotoy et al. 6,303,523 B2 10/2001 Cheung 6,305,898 B1 10/2001 Yamagishi et al. 6,311,016 B1 10/2001 Yanagawa et al. 6,312,525 B1 11/2001 Bright et al. 6,315,512 B1 11/2001 Tabrizi et al. 6,316,162 B1 11/2001 Jung et al. 6,321,680 B2 11/2001 Cook et al. 6,321,780 B1 11/2001 Iwabuchi D451,893 S 12/2001 Robson D452,220 S 12/2001 Robson 6,325,858 B1 12/2001 Wengert 6,326,322 B1 12/2001 Kim et al. 6,326,597 B1 12/2001 Lubomirsky et al. 6,329,297 B1 12/2001 Balish 6,335,049 B1 1/2002 Basceri 6,342,427 B1 1/2002 Choi et al. 6,344,084 B1 2/2002 Koinuma et al. 6,344,232 B1 2/2002 Jones et al. 6,346,419 B1 2/2002 Ryerson et al. 6,347,636 B1 2/2002 Xia 6,350,391 B1 2/2002 Livshits et al. 6,352,049 B1 3/2002 Yin et al. 6,352,945 B1 3/2002 Matsuki D455,024 S 4/2002 Mimick et al. 6,367,410 B1 4/2002 Leahey et al. 6,368,773 B1 4/2002 Jung et al. 6,368,987 B1 4/2002 Kopacz et al. 6,370,796 B1 4/2002 Zucker 6,372,583 B1 4/2002 Tyagi 6,374,831 B1 4/2002 Chandran 6,375,312 B1 4/2002 Ikeda et al. 6,375,749 B1 4/2002 Boydston et al. 6,375,750 B1 4/2002 Van Os et al. 6,379,466 B1 * 4/2002 Sahin C23C 16/455 118/715</p> <p>D457,609 S 5/2002 Piano 6,383,566 B1 5/2002 Zagdoun 6,383,955 B1 5/2002 Matsuki 6,387,207 B1 5/2002 Janakiraman 6,390,754 B2 5/2002 Yamaga et al. 6,391,803 B1 5/2002 Kim et al. 6,395,650 B1 5/2002 Callegari et al. 6,398,184 B1 6/2002 Sowada et al. 6,402,806 B1 6/2002 Schmitt et al. 6,410,433 B1 6/2002 Hautala et al. 6,410,459 B2 6/2002 Blalock et al. 6,410,463 B1 6/2002 Matsuki 6,413,321 B1 7/2002 Kim et al. 6,413,583 B1 7/2002 Moghadam et al. 6,420,279 B1 7/2002 Ono et al. 6,423,949 B1 7/2002 Chen et al. D461,233 S 8/2002 Whalen D461,882 S 8/2002 Piano 6,428,859 B1 8/2002 Chiang et al. 6,432,479 B2 8/2002 Chang et al. 6,432,849 B1 8/2002 Endo et al. 6,433,298 B1 8/2002 Ishii 6,435,798 B1 8/2002 Satoh</p>
--	--

(56)

References Cited

U.S. PATENT DOCUMENTS

- | | | | | | |
|--------------|---------|---------------------|--------------|---------|------------------|
| 6,435,865 B1 | 8/2002 | Tseng et al. | 6,565,763 B1 | 5/2003 | Asakawa et al. |
| 6,436,819 B1 | 8/2002 | Zhang | 6,566,278 B1 | 5/2003 | Harvey et al. |
| 6,437,444 B2 | 8/2002 | Andideh | 6,569,239 B2 | 5/2003 | Arai et al. |
| 6,438,502 B1 | 8/2002 | Awtrey | 6,569,971 B2 | 5/2003 | Roh et al. |
| 6,439,822 B1 | 8/2002 | Kimura et al. | 6,573,030 B1 | 6/2003 | Fairbairn et al. |
| 6,440,261 B1 | 8/2002 | Tepman et al. | 6,574,644 B2 | 6/2003 | Hsu et al. |
| 6,441,350 B1 | 8/2002 | Stoddard et al. | 6,576,062 B2 | 6/2003 | Matsuse |
| 6,445,574 B1 | 9/2002 | Saw et al. | 6,576,064 B2 | 6/2003 | Griffiths et al. |
| 6,446,573 B2 | 9/2002 | Hirayama et al. | 6,576,300 B1 | 6/2003 | Berry et al. |
| 6,447,232 B1 | 9/2002 | Davis et al. | 6,576,564 B2 | 6/2003 | Agarwal |
| 6,447,651 B1 | 9/2002 | Ishikawa et al. | 6,578,589 B1 | 6/2003 | Mayusumi |
| 6,447,937 B1 | 9/2002 | Murakawa et al. | 6,579,833 B1 | 6/2003 | McNallan et al. |
| 6,448,192 B1 | 9/2002 | Kaushik | 6,580,050 B1 | 6/2003 | Miller et al. |
| 6,450,117 B1 | 9/2002 | Murugesu et al. | 6,582,174 B1 | 6/2003 | Hayashi |
| 6,450,757 B1 | 9/2002 | Saeki | 6,583,048 B1 | 6/2003 | Vincent et al. |
| 6,451,713 B1 | 9/2002 | Tay et al. | 6,587,108 B1 | 7/2003 | Guerlain et al. |
| 6,454,860 B2 | 9/2002 | Metzner et al. | 6,589,352 B1 | 7/2003 | Yudovsky et al. |
| 6,455,098 B2 | 9/2002 | Tran et al. | 6,589,707 B2 | 7/2003 | Lee et al. |
| 6,455,225 B1 | 9/2002 | Kong et al. | 6,589,868 B2 | 7/2003 | Rossman |
| 6,455,445 B2 | 9/2002 | Matsuki | 6,590,251 B2 | 7/2003 | Kang et al. |
| 6,461,435 B1 | 10/2002 | Littau et al. | 6,594,550 B1 | 7/2003 | Okrah |
| 6,461,436 B1 | 10/2002 | Campbell et al. | 6,596,653 B2 | 7/2003 | Tan |
| 6,468,924 B2 | 10/2002 | Lee | 6,598,559 B1 | 7/2003 | Vellore et al. |
| 6,471,779 B1 | 10/2002 | Nishio et al. | 6,602,806 B1 | 8/2003 | Xia et al. |
| 6,472,266 B1 | 10/2002 | Yu et al. | 6,607,868 B2 | 8/2003 | Choi |
| 6,475,276 B1 | 11/2002 | Elers et al. | 6,607,948 B1 | 8/2003 | Sugiyama et al. |
| 6,475,930 B1 | 11/2002 | Junker et al. | 6,608,745 B2 | 8/2003 | Tsuruta et al. |
| 6,478,872 B1 | 11/2002 | Chae et al. | 6,610,375 B2 | 8/2003 | Akiba et al. |
| 6,481,945 B1 | 11/2002 | Hasper et al. | 6,620,251 B2 | 9/2003 | Kitano |
| 6,482,331 B2 | 11/2002 | Lu et al. | 6,624,064 B1 | 9/2003 | Sahin |
| 6,482,663 B1 | 11/2002 | Buckland | 6,627,268 B1 | 9/2003 | Fair et al. |
| 6,483,989 B1 | 11/2002 | Okada et al. | 6,627,503 B2 | 9/2003 | Ma et al. |
| 6,488,774 B1 | 12/2002 | Horie et al. | 6,632,478 B2 | 10/2003 | Gaillard et al. |
| 6,490,493 B1 | 12/2002 | Dharnipragada | 6,633,364 B2 | 10/2003 | Hayashi |
| 6,492,625 B1 | 12/2002 | Boguslavskiy et al. | 6,635,115 B1 | 10/2003 | Fairbairn et al. |
| 6,494,065 B2 | 12/2002 | Babbitt | 6,635,117 B1 | 10/2003 | Kinnard et al. |
| 6,494,998 B1 | 12/2002 | Brcka | 6,635,578 B1 | 10/2003 | Xu et al. |
| 6,496,819 B1 | 12/2002 | Bello et al. | 6,638,839 B2 | 10/2003 | Deng et al. |
| 6,497,734 B1 | 12/2002 | Barber et al. | 6,640,145 B2 | 10/2003 | Hoffberg et al. |
| 6,497,767 B1 | 12/2002 | Okase et al. | 6,645,304 B2 | 11/2003 | Yamaguchi |
| 6,498,091 B1 | 12/2002 | Chen et al. | 6,648,974 B1 | 11/2003 | Ogliari et al. |
| 6,499,533 B2 | 12/2002 | Yamada | 6,649,921 B1 | 11/2003 | Cekic et al. |
| 6,500,487 B1 | 12/2002 | Holst et al. | 6,652,924 B2 | 11/2003 | Sherman |
| 6,502,530 B1 | 1/2003 | Turlot et al. | 6,656,281 B1 | 12/2003 | Ueda |
| 6,503,079 B2 | 1/2003 | Kogano et al. | 6,660,662 B2 | 12/2003 | Ishikawa et al. |
| 6,503,365 B1 | 1/2003 | Kim et al. | 6,662,817 B2 | 12/2003 | Yamagishi |
| 6,503,562 B1 | 1/2003 | Saito et al. | 6,673,196 B1 | 1/2004 | Oyabu |
| 6,503,826 B1 | 1/2003 | Oda | 6,676,290 B1 | 1/2004 | Lu |
| 6,506,009 B1 | 1/2003 | Nulman et al. | 6,679,194 B2 | 1/2004 | Ham et al. |
| 6,506,253 B2 | 1/2003 | Sakuma | 6,682,971 B2 | 1/2004 | Tsuneda et al. |
| 6,507,410 B1 | 1/2003 | Robertson et al. | 6,682,973 B1 | 1/2004 | Paton et al. |
| 6,511,539 B1 | 1/2003 | Raaijmakers | D486,891 S | 2/2004 | Cronce |
| 6,514,313 B1 | 2/2003 | Spiegelman | 6,684,659 B1 | 2/2004 | Tanaka et al. |
| 6,514,666 B1 | 2/2003 | Choi et al. | 6,686,281 B2 | 2/2004 | Yamazaki et al. |
| 6,521,295 B1 | 2/2003 | Remington | 6,688,784 B1 | 2/2004 | Templeton |
| 6,521,547 B1 | 2/2003 | Chang et al. | 6,689,220 B1 | 2/2004 | Nguyen |
| 6,527,884 B1 | 3/2003 | Takakuwa et al. | 6,692,575 B1 | 2/2004 | Omstead et al. |
| 6,528,171 B1 | 3/2003 | Endler et al. | 6,692,576 B2 | 2/2004 | Halpin et al. |
| 6,528,430 B2 | 3/2003 | Kwan | 6,696,367 B1 | 2/2004 | Aggarwal |
| 6,528,752 B1 | 3/2003 | Ishii et al. | 6,699,003 B2 | 3/2004 | Saeki |
| 6,528,767 B2 | 3/2003 | Bagley et al. | 6,699,399 B1 | 3/2004 | Qian et al. |
| 6,530,994 B1 | 3/2003 | Mahawili | 6,709,989 B2 | 3/2004 | Ramdani et al. |
| 6,531,193 B2 | 3/2003 | Fonash et al. | 6,710,364 B2 | 3/2004 | Guldi et al. |
| 6,531,412 B2 | 3/2003 | Conti et al. | 6,710,857 B2 | 3/2004 | Kondo |
| 6,534,133 B1 | 3/2003 | Kaloyeros et al. | 6,713,824 B1 | 3/2004 | Mikata |
| 6,534,395 B2 | 3/2003 | Werkhoven et al. | 6,715,949 B1 | 4/2004 | Fisher et al. |
| 6,536,950 B1 | 3/2003 | Green | 6,716,571 B2 | 4/2004 | Gabriel |
| 6,539,891 B1 | 4/2003 | Kang et al. | 6,720,260 B1 | 4/2004 | Fair et al. |
| 6,540,469 B2 | 4/2003 | Matsunaga et al. | 6,720,531 B1 | 4/2004 | Jacobson et al. |
| 6,544,906 B2 | 4/2003 | Rotondaro et al. | 6,722,837 B2 | 4/2004 | Inui |
| 6,552,209 B1 | 4/2003 | Lei et al. | 6,723,642 B1 | 4/2004 | Lim et al. |
| 6,558,517 B2 | 5/2003 | Basceri | 6,730,614 B1 | 5/2004 | Lim et al. |
| 6,558,755 B2 | 5/2003 | Berry et al. | 6,732,006 B2 | 5/2004 | Haanstra et al. |
| 6,559,026 B1 | 5/2003 | Rossman et al. | 6,734,090 B2 | 5/2004 | Agarwala et al. |
| 6,562,094 B2 | 5/2003 | Denker et al. | 6,740,853 B1 | 5/2004 | Johnson et al. |
| | | | 6,743,475 B2 | 6/2004 | Skarp et al. |
| | | | 6,743,738 B2 | 6/2004 | Todd et al. |
| | | | 6,745,095 B1 | 6/2004 | Ben-Dov |
| | | | 6,746,240 B2 | 6/2004 | de Ridder et al. |

(56)

References Cited

U.S. PATENT DOCUMENTS

6,746,308 B1	6/2004	Bode et al.	6,929,699 B2	8/2005	Whitesell
6,749,671 B2	6/2004	Holst et al.	6,929,700 B2	8/2005	Tan et al.
6,753,507 B2	6/2004	Fure et al.	6,930,041 B2	8/2005	Agarwal
6,755,221 B2	6/2004	Jeong et al.	6,930,059 B2	8/2005	Conley, Jr. et al.
6,756,085 B2	6/2004	Waldfried	6,935,269 B2	8/2005	Lee et al.
6,756,293 B2	6/2004	Li et al.	6,939,817 B2	9/2005	Sandhu et al.
6,756,318 B2	6/2004	Nguyen et al.	6,942,753 B2	9/2005	Choi et al.
6,759,098 B2	7/2004	Han	6,949,204 B1	9/2005	Lenz et al.
6,760,981 B2	7/2004	Leap	6,951,587 B1	10/2005	Narushima
6,767,447 B2	7/2004	Uno et al.	6,952,656 B1	10/2005	Cordova et al.
D494,552 S	8/2004	Tezuka et al.	6,953,609 B2	10/2005	Carollo
6,783,875 B2	8/2004	Yamada et al.	6,955,741 B2	10/2005	Yamagishi
6,784,108 B1	8/2004	Donohoe et al.	6,955,836 B2	10/2005	Kumagai et al.
D496,008 S	9/2004	Takahashi et al.	6,955,928 B1	10/2005	Brennan
D497,977 S	11/2004	Engelbrektsson	6,963,052 B2	11/2005	Kuibira et al.
6,811,960 B2	11/2004	Lee et al.	6,972,055 B2	12/2005	Sferlazzo
6,812,157 B1	11/2004	Gadgil	6,972,478 B1	12/2005	Waite et al.
6,815,350 B2	11/2004	Kim et al.	6,974,781 B2	12/2005	Timmermans et al.
6,815,352 B1	11/2004	Tamura et al.	6,975,921 B2	12/2005	Verhaar
6,818,864 B2	11/2004	Ptak	6,976,822 B2	12/2005	Woodruff
6,820,570 B2	11/2004	Kilpela et al.	6,981,832 B2	1/2006	Zinger et al.
6,821,910 B2	11/2004	Adomaitis et al.	6,982,046 B2	1/2006	Srivastava et al.
6,824,665 B2	11/2004	Shelnut et al.	6,982,103 B2	1/2006	Basceri et al.
6,825,134 B2	11/2004	Law et al.	6,984,591 B1	1/2006	Buchanan et al.
D499,620 S	12/2004	Homer-Richardson et al.	6,984,595 B1	1/2006	Yamazaki
6,827,789 B2	12/2004	Lee et al.	6,985,788 B2	1/2006	Haanstra et al.
6,828,235 B2	12/2004	Takano	6,986,914 B2	1/2006	Elers et al.
6,831,004 B2	12/2004	Byun	6,987,155 B2	1/2006	Roh et al.
6,833,024 B2	12/2004	Holst et al.	6,990,430 B2	1/2006	Hosek
6,835,039 B2	12/2004	Van Den Berg	7,005,227 B2	2/2006	Yueh et al.
6,838,122 B2	1/2005	Basceri et al.	7,005,391 B2	2/2006	Min
6,841,201 B2	1/2005	Shanov et al.	7,008,879 B2	3/2006	Lee et al.
6,843,202 B2	1/2005	Kusuda	7,010,580 B1	3/2006	Fu et al.
6,846,146 B2	1/2005	Inui	7,017,514 B1	3/2006	Shepherd et al.
6,846,515 B2	1/2005	Vrtis	7,018,941 B2	3/2006	Cui et al.
6,846,742 B2	1/2005	Rossmann	7,021,330 B2	4/2006	Maula et al.
6,847,014 B1	1/2005	Benjamin et al.	7,021,881 B2	4/2006	Yamagishi
6,858,524 B2	2/2005	Haukka et al.	7,036,453 B2	5/2006	Ishikawa et al.
6,858,547 B2	2/2005	Metzner	7,041,609 B2	5/2006	Vaartstra
6,861,642 B2	3/2005	Ichiki et al.	7,045,430 B2	5/2006	Ahn et al.
6,863,019 B2	3/2005	Shamouilian	7,049,226 B2	5/2006	Chung et al.
6,863,281 B2	3/2005	Endou et al.	7,049,247 B2	5/2006	Gates et al.
6,864,041 B2	3/2005	Brown	7,052,584 B2	5/2006	Basceri
6,867,859 B1	3/2005	Powell	7,053,009 B2	5/2006	Conley, Jr. et al.
6,872,258 B2	3/2005	Park et al.	7,055,263 B2	6/2006	Wu et al.
6,872,259 B2	3/2005	Strang	7,055,875 B2	6/2006	Bonora
D504,142 S	4/2005	Homer-Richardson et al.	7,062,161 B2	6/2006	Kusuda et al.
6,874,247 B1	4/2005	Hsu	7,070,178 B2	7/2006	Van Der Toorn et al.
6,874,480 B1	4/2005	Ismailov	7,071,051 B1	7/2006	Jeon et al.
6,875,477 B2	4/2005	Trickett et al.	7,073,834 B2	7/2006	Matsumoto et al.
6,875,677 B1	4/2005	Conley, Jr. et al.	7,074,690 B1	7/2006	Gauri et al.
6,876,017 B2	4/2005	Goodner	7,080,545 B2	7/2006	Dimeo et al.
6,876,191 B2	4/2005	de Ridder	7,084,060 B1	8/2006	Furukawa
6,878,206 B2	4/2005	Tzu et al.	7,084,079 B2	8/2006	Conti et al.
6,878,402 B2	4/2005	Chiang et al.	7,085,623 B2	8/2006	Siegers
6,883,733 B1	4/2005	Lind	7,086,347 B2	8/2006	Howald et al.
6,884,066 B2	4/2005	Nguyen et al.	7,088,003 B2	8/2006	Gates et al.
6,884,295 B2	4/2005	Ishii	7,090,394 B2	8/2006	Hashikura et al.
6,884,319 B2	4/2005	Kim	7,092,287 B2	8/2006	Beulens et al.
6,884,475 B2	4/2005	Basceri	7,098,149 B2	8/2006	Lukas
D505,590 S	5/2005	Greiner	7,101,763 B1	9/2006	Anderson et al.
6,889,211 B1	5/2005	Yoshiura et al.	7,108,753 B2	9/2006	Wood
6,889,864 B2	5/2005	Lindfors et al.	7,109,098 B1	9/2006	Ramaswamy et al.
6,890,596 B2	5/2005	Sarigiannis et al.	7,109,114 B2	9/2006	Chen et al.
6,895,158 B2	5/2005	Alyward et al.	7,111,232 B1	9/2006	Bascom
6,899,507 B2	5/2005	Yamagishi et al.	7,115,305 B2	10/2006	Bronikowski et al.
6,902,395 B2	6/2005	Oosterlaken et al.	7,115,838 B2	10/2006	Kurara et al.
6,909,839 B2	6/2005	Wang et al.	7,122,085 B2	10/2006	Shero et al.
6,911,092 B2	6/2005	Sneh	7,122,222 B2	10/2006	Xiao et al.
6,913,152 B2	7/2005	Zuk	7,129,165 B2	10/2006	Basol et al.
6,913,796 B2	7/2005	Albano et al.	7,132,360 B2	11/2006	Schaeffer et al.
6,916,398 B2	7/2005	Chen et al.	7,135,421 B2	11/2006	Ahn et al.
6,916,559 B2	7/2005	Murakawa et al.	7,143,897 B1	12/2006	Guzman et al.
6,917,755 B2	7/2005	Nguyen et al.	7,144,809 B2	12/2006	Elers et al.
6,924,078 B2	8/2005	Lee et al.	7,147,766 B2	12/2006	Uzoh et al.
			7,153,542 B2	12/2006	Nguyen et al.
			7,156,380 B2	1/2007	Soininen
			7,163,393 B2	1/2007	Adachi et al.
			7,163,721 B2	1/2007	Zhang et al.

(56)

References Cited

U.S. PATENT DOCUMENTS

7,163,900 B2	1/2007	Weber	7,381,644 B1	6/2008	Soubramonium et al.
7,168,852 B2	1/2007	Linnarsson	7,387,685 B2	6/2008	Choi et al.
7,172,497 B2	2/2007	Basol et al.	7,393,207 B2	7/2008	Imai
7,173,216 B2	2/2007	Ptak	7,393,418 B2	7/2008	Yokogawa
7,183,229 B2	2/2007	Yamanaka	7,393,736 B2	7/2008	Ahn et al.
7,186,648 B1	3/2007	Rozbicki	7,393,765 B2	7/2008	Hanawa et al.
7,192,824 B2	3/2007	Ahn et al.	7,396,491 B2	7/2008	Marking et al.
7,192,892 B2	3/2007	Ahn et al.	7,399,388 B2	7/2008	Moghadam et al.
7,195,479 B2	3/2007	Beatty et al.	7,399,570 B2	7/2008	Lee et al.
7,195,693 B2	3/2007	Cowans	7,402,534 B2	7/2008	Mahajani
D541,125 S	4/2007	Gaudron	7,405,166 B2	7/2008	Liang et al.
7,198,447 B2	4/2007	Morimitsu et al.	7,405,454 B2	7/2008	Ahn et al.
7,201,943 B2	4/2007	Park et al.	D575,713 S	8/2008	Ratcliffe
7,202,148 B2	4/2007	Chen et al.	7,410,290 B2	8/2008	Tanaka
7,202,512 B2	4/2007	Chen et al.	7,410,666 B2	8/2008	Elers
7,204,886 B2	4/2007	Chen et al.	7,411,352 B2	8/2008	Madocks
7,204,887 B2	4/2007	Kawamura et al.	7,414,281 B1	8/2008	Fastow
7,205,246 B2	4/2007	MacNeil et al.	D576,001 S	9/2008	Brunderman
7,205,247 B2	4/2007	Lee et al.	7,422,635 B2	9/2008	Zheng et al.
7,207,763 B2	4/2007	Lee	7,422,636 B2	9/2008	Ishizaka
7,208,198 B2	4/2007	Basceri et al.	7,422,653 B2	9/2008	Blahnik et al.
7,208,389 B1	4/2007	Tipton et al.	7,422,775 B2	9/2008	Ramaswamy et al.
7,210,925 B2	5/2007	Adachi	7,425,224 B2	9/2008	Nguyen
7,211,524 B2	5/2007	Ryu et al.	7,427,571 B2	9/2008	Lindeboom et al.
7,211,525 B1	5/2007	Shanker	7,429,532 B2	9/2008	Ramaswamy et al.
7,214,630 B1	5/2007	Varadarajan et al.	7,431,966 B2	10/2008	Derderian et al.
7,217,617 B2	5/2007	Basceri	7,432,476 B2	10/2008	Morita et al.
7,223,014 B2	5/2007	Lojen	7,437,060 B2	10/2008	Wang et al.
7,208,413 B2	6/2007	Byun et al.	7,442,275 B2	10/2008	Cowans
7,234,476 B2	6/2007	Arai	7,456,429 B2	11/2008	Levy
7,235,137 B2	6/2007	Kitayama et al.	D583,395 S	12/2008	Ueda
7,235,482 B2	6/2007	Wu	7,467,632 B2	12/2008	Lee et al.
7,235,501 B2	6/2007	Ahn et al.	7,473,655 B2	1/2009	Wang et al.
7,238,596 B2	7/2007	Kouvetakis et al.	7,475,588 B2	1/2009	Dimeo et al.
7,238,616 B2	7/2007	Agarwal	7,476,291 B2	1/2009	Wang et al.
7,238,653 B2	7/2007	Lee et al.	7,479,198 B2	1/2009	Guffrey
7,256,375 B2	8/2007	Oosterlaken	7,482,247 B1	1/2009	Papasouliotis
7,265,061 B1	9/2007	Cho et al.	7,482,283 B2	1/2009	Yamasaki et al.
7,274,867 B2	9/2007	Peukert	D585,968 S	2/2009	Elkins et al.
D553,104 S	10/2007	Oohashi et al.	7,489,389 B2	2/2009	Shibazaki et al.
7,279,256 B2	10/2007	Son	7,494,882 B2	2/2009	Vitale
7,290,813 B2	11/2007	Bonora	7,497,614 B2	3/2009	Gaff
7,294,581 B2	11/2007	Haverkort et al.	7,498,242 B2	3/2009	Kumar et al.
7,296,460 B2	11/2007	Dimeo et al.	7,501,292 B2	3/2009	Matsushita et al.
7,297,641 B2	11/2007	Todd et al.	7,501,355 B2	3/2009	Bhatia et al.
7,298,009 B2	11/2007	Yan et al.	7,503,980 B2	3/2009	Kida et al.
7,301,623 B1	11/2007	Madsen et al.	7,504,344 B2	3/2009	Matsuki et al.
D556,704 S	12/2007	Nakamura et al.	D590,933 S	4/2009	Vansell
D557,226 S	12/2007	Uchino et al.	7,514,058 B1	4/2009	Hitzman et al.
D558,021 S	12/2007	Lawrence	7,514,375 B1	4/2009	Shanker et al.
7,307,028 B2	12/2007	Goto et al.	D593,585 S	6/2009	Ota et al.
7,307,178 B2	12/2007	Kiyomori et al.	D593,969 S	6/2009	Li
7,312,148 B2	12/2007	Ramaswamy et al.	7,541,297 B2	6/2009	Mallick et al.
7,312,162 B2	12/2007	Ramaswamy et al.	7,544,398 B1	6/2009	Chang et al.
7,312,494 B2	12/2007	Ahn et al.	7,547,363 B2	6/2009	Tomiyasu et al.
D559,993 S	1/2008	Nagakubo et al.	7,547,633 B2	6/2009	Ranish et al.
D559,994 S	1/2008	Nagakubo et al.	7,550,396 B2	6/2009	Frohberg et al.
7,320,544 B2	1/2008	Hsieh	D596,476 S	7/2009	Welch
7,323,401 B2	1/2008	Ramaswamy et al.	7,561,982 B2	7/2009	Rund et al.
7,326,656 B2	2/2008	Brask et al.	7,563,715 B2	7/2009	Haukka et al.
7,326,657 B2	2/2008	Xia et al.	7,566,891 B2	7/2009	Rocha-Alvarez et al.
7,327,948 B1	2/2008	Shrinivasan	7,569,193 B2	8/2009	Ferron et al.
7,329,947 B2	2/2008	Adachi et al.	7,575,968 B2	8/2009	Sadaka et al.
7,335,611 B2	2/2008	Ramaswamy et al.	7,579,285 B2	8/2009	Zimmerman et al.
7,351,057 B2	4/2008	Berenbak et al.	7,579,785 B2	8/2009	Shinmen et al.
7,354,847 B2	4/2008	Chan et al.	D600,223 S	9/2009	Aggarwal
7,354,873 B2	4/2008	Fukazawa et al.	7,582,555 B1	9/2009	Lang
7,356,762 B2	4/2008	van Driel	7,582,575 B2	9/2009	Fukazawa et al.
7,357,138 B2	4/2008	Ji et al.	7,589,003 B2	9/2009	Kouvetakis et al.
7,361,447 B2	4/2008	Jung	7,589,028 B1	9/2009	Cho et al.
7,375,035 B2	5/2008	Heden et al.	7,589,029 B2	9/2009	Derderian et al.
7,376,520 B2	5/2008	Wong	7,591,601 B2	9/2009	Matsuoka et al.
7,379,785 B2	5/2008	Higashi et al.	D602,575 S	10/2009	Breda
D571,383 S	6/2008	Ota et al.	7,598,513 B2	10/2009	Kouvetakis et al.
D571,831 S	6/2008	Ota et al.	7,601,223 B2	10/2009	Lindfors et al.
			7,601,225 B2	10/2009	Tuominen et al.
			7,601,652 B2	10/2009	Singh et al.
			7,611,640 B1	11/2009	Howald et al.
			7,611,751 B2	11/2009	Elers

(56)

References Cited

U.S. PATENT DOCUMENTS

7,611,980 B2	11/2009	Wells et al.	7,795,160 B2	10/2010	Wang et al.
7,618,226 B2	11/2009	Takizawa	7,806,587 B2	10/2010	Kobayashi
7,621,672 B2	11/2009	Ripley	7,807,566 B2	10/2010	Tsuji et al.
7,622,369 B1	11/2009	Lee et al.	7,807,578 B2	10/2010	Bencher et al.
7,622,378 B2	11/2009	Liu et al.	7,816,278 B2	10/2010	Reed et al.
7,623,940 B2	11/2009	Huskamp et al.	7,824,492 B2	11/2010	Tois et al.
D606,952 S	12/2009	Lee	7,825,040 B1	11/2010	Fukazawa et al.
7,625,820 B1	12/2009	Papasouliotis	7,829,460 B2	11/2010	Streck et al.
7,629,277 B2	12/2009	Ghatnagar	7,833,348 B2	11/2010	Wada et al.
7,632,549 B2	12/2009	Goundar	7,833,353 B2	11/2010	Furukawahara et al.
7,640,142 B2	12/2009	Tachikawa et al.	7,838,084 B2	11/2010	Derderian et al.
7,645,341 B2	1/2010	Kennedy et al.	7,842,518 B2	11/2010	Miyajima
7,645,484 B2	1/2010	Ishizaka	7,842,622 B1	11/2010	Lee et al.
7,648,927 B2	1/2010	Singh et al.	D629,874 S	12/2010	Hermans
7,651,269 B2	1/2010	Comendant	7,850,449 B2	12/2010	Yang et al.
7,651,583 B2	1/2010	Kent et al.	7,851,019 B2	12/2010	Tuominen et al.
7,651,955 B2	1/2010	Ranish et al.	7,851,232 B2	12/2010	van Schravendijk et al.
7,651,959 B2	1/2010	Fukazawa et al.	7,858,519 B2	12/2010	Liu et al.
7,651,961 B2	1/2010	Clark	7,858,533 B2	12/2010	Liu et al.
D609,652 S	2/2010	Nagasaka et al.	7,865,070 B2	1/2011	Nakamura
D609,655 S	2/2010	Sugimoto	7,871,198 B2	1/2011	Rempe et al.
7,661,299 B2	2/2010	Kusunoki	7,874,726 B2	1/2011	Jacobs et al.
7,670,432 B2	3/2010	Li	7,884,918 B2	2/2011	Hattori
7,674,726 B2	3/2010	Hasper et al.	7,888,233 B1	2/2011	Gauri
7,678,197 B2	3/2010	Maki	7,894,474 B1	2/2011	Bell
7,678,715 B2	3/2010	Mungekar et al.	D634,329 S	3/2011	Wastrom
7,682,454 B2	3/2010	Sneh	D634,719 S	3/2011	Yasuda et al.
7,682,657 B2	3/2010	Sherman	7,897,215 B1	3/2011	Fair et al.
D613,829 S	4/2010	Griffin et al.	7,897,217 B2	3/2011	Faguet
D614,153 S	4/2010	Fondurulia et al.	7,902,009 B2	3/2011	Simonelli et al.
D614,267 S	4/2010	Breda	7,902,582 B2	3/2011	Forbes et al.
D614,268 S	4/2010	Breda	7,906,174 B1	3/2011	Wu et al.
D614,593 S	4/2010	Lee	7,910,288 B2	3/2011	Abatchev et al.
7,690,881 B2	4/2010	Yamagishi	7,910,494 B2	3/2011	Dip et al.
7,691,205 B2	4/2010	Ikedo	7,915,139 B1	3/2011	Lang
7,692,171 B2	4/2010	Kaszuba et al.	7,915,667 B2	3/2011	Knoefler et al.
7,695,808 B2	4/2010	Tuma	7,919,142 B2	4/2011	Yeom et al.
D616,390 S	5/2010	Sato	7,919,416 B2	4/2011	Lee et al.
D616,394 S	5/2010	Sato	7,925,378 B2	4/2011	Gilchrist et al.
7,712,435 B2	5/2010	Yoshizaki et al.	7,935,940 B1	5/2011	Smargiassi
7,713,874 B2	5/2010	Milligan	7,939,447 B2	5/2011	Bauer et al.
7,716,993 B2	5/2010	Ozawa et al.	7,942,969 B2	5/2011	Riker et al.
7,718,930 B2	5/2010	Kawasaki et al.	7,946,762 B2	5/2011	Yednak
7,720,560 B2	5/2010	Menser et al.	7,951,262 B2	5/2011	Koshiishi et al.
7,723,648 B2	5/2010	Tsukamoto et al.	7,955,516 B2	6/2011	Chandrachood et al.
7,725,012 B2	5/2010	Aggarwal et al.	7,955,646 B2	6/2011	Cruse et al.
7,727,864 B2	6/2010	Elers	7,955,650 B2	6/2011	Tsuji
7,732,343 B2	6/2010	Niroomand et al.	7,957,708 B2	6/2011	Karschnia et al.
7,736,437 B2	6/2010	Cadwell et al.	7,963,736 B2	6/2011	Takizawa et al.
7,736,528 B2	6/2010	Okita et al.	7,967,913 B2	6/2011	Hua et al.
7,736,600 B2	6/2010	Clark et al.	7,972,980 B2	7/2011	Lee et al.
7,737,035 B1	6/2010	Lind et al.	7,977,256 B2	7/2011	Liu et al.
7,740,437 B2	6/2010	de Ridder et al.	7,981,751 B2	7/2011	Zhu et al.
7,740,705 B2	6/2010	Li	D643,055 S	8/2011	Takahashi
7,745,346 B2	6/2010	Hausmann et al.	7,989,736 B2	8/2011	Park et al.
7,748,760 B2	7/2010	Kushida	7,992,318 B2	8/2011	Kawaji
7,749,563 B2	7/2010	Zheng et al.	7,993,457 B1	8/2011	Krotov et al.
7,753,584 B2	7/2010	Gambino et al.	7,994,070 B1	8/2011	Dip et al.
7,754,621 B2	7/2010	Putjkonen	7,994,721 B2	8/2011	Espiau et al.
7,758,698 B2	7/2010	Bang et al.	7,997,795 B2	8/2011	Schwagerman et al.
7,763,869 B2	7/2010	Matsushita et al.	7,998,875 B2	8/2011	DeYoung
7,767,262 B2	8/2010	Clark	8,003,174 B2	8/2011	Fukazawa
7,771,796 B2	8/2010	Kohno et al.	8,003,919 B2	8/2011	Goto et al.
7,780,440 B2	8/2010	Shibagaki et al.	8,004,198 B2	8/2011	Bakre et al.
7,780,789 B2	8/2010	Wu et al.	8,020,315 B2	9/2011	Nishimura
7,781,352 B2	8/2010	Fukazawa et al.	8,030,129 B2	10/2011	Jeong
7,789,559 B2	9/2010	Waser et al.	8,033,771 B1	10/2011	Gage et al.
7,789,965 B2	9/2010	Matsushita et al.	8,038,835 B2	10/2011	Hayashi et al.
7,790,633 B1	9/2010	Tarafdar et al.	8,041,197 B2	10/2011	Kasai et al.
7,794,546 B2	9/2010	Li	8,041,450 B2	10/2011	Takizawa et al.
7,798,096 B2	9/2010	Mahajani et al.	8,043,972 B1	10/2011	Liu et al.
7,799,300 B2	9/2010	Lindfors et al.	8,046,193 B2	10/2011	Yetter et al.
7,799,706 B2	9/2010	Yeom et al.	8,047,711 B2	11/2011	Ploechinger
7,803,722 B2	9/2010	Liang	8,048,783 B2	11/2011	Chung et al.
D625,977 S	10/2010	Watson et al.	8,051,799 B2	11/2011	Itagaki et al.
			8,052,794 B2	11/2011	Sumakeris et al.
			8,055,378 B2	11/2011	Numakura
			8,060,252 B2	11/2011	Gage et al.
			8,083,853 B2	11/2011	Choi et al.

(56)

References Cited

U.S. PATENT DOCUMENTS

RE43,023 E	12/2011	Nakashima et al.	8,324,699 B2	12/2012	Ichijo et al.
D649,986 S	12/2011	Fujikata et al.	8,328,939 B2	12/2012	Choi et al.
D651,291 S	12/2011	Liebson et al.	8,329,599 B2	12/2012	Fukazawa et al.
8,071,451 B2	12/2011	Berry	8,334,219 B2	12/2012	Lee et al.
8,071,452 B2	12/2011	Raisanen	8,338,809 B2	12/2012	Yang et al.
8,072,578 B2	12/2011	Yasuda et al.	8,349,083 B2	1/2013	Takasuka et al.
8,076,230 B2	12/2011	Wei	D676,943 S	2/2013	Kluss
8,076,237 B2	12/2011	Uzoh	8,367,528 B2	2/2013	Bauer et al.
8,076,250 B1	12/2011	Rajagopalan	8,372,204 B2	2/2013	Nakamura
8,076,251 B2	12/2011	Akae et al.	8,378,464 B2	2/2013	Kato et al.
8,078,310 B2	12/2011	Nishimoto et al.	8,382,939 B2	2/2013	Kutney et al.
8,082,946 B2	12/2011	Laverdiere et al.	8,393,091 B2	3/2013	Kawamoto
8,084,104 B2	12/2011	Shinriki et al.	8,394,466 B2	3/2013	Hong et al.
8,084,372 B2	12/2011	You et al.	8,398,773 B2	3/2013	Jdira et al.
D652,896 S	1/2012	Gether	8,402,918 B2 *	3/2013	Kadkhodayan H01J 37/3255 118/723 E
8,092,604 B2	1/2012	Tomiyasu et al.	8,404,499 B2	3/2013	Moffatt
8,100,583 B2	1/2012	Aggarwal	8,415,258 B2	4/2013	Akae
D653,734 S	2/2012	Sisk	8,415,259 B2	4/2013	Lee et al.
D654,882 S *	2/2012	Honma D13/182	8,419,959 B2 *	4/2013	Bettencourt H01J 37/32568 216/67
D654,884 S	2/2012	Honma	8,425,682 B2	4/2013	Wang et al.
D655,055 S	2/2012	Toll	8,440,259 B2	5/2013	Chiang et al.
8,110,099 B2	2/2012	Hersey et al.	8,444,120 B2	5/2013	Gregg et al.
8,114,734 B2	2/2012	Yang et al.	8,445,075 B2	5/2013	Xu et al.
8,119,466 B2	2/2012	Avouris	8,450,191 B2	5/2013	Wang
8,119,527 B1	2/2012	Chadrashekar et al.	8,454,749 B2	6/2013	Li
D655,260 S *	3/2012	Honma D13/182	8,465,811 B2	6/2013	Ueda
D655,261 S *	3/2012	Honma D13/182	8,465,903 B2	6/2013	Weidman et al.
D655,599 S	3/2012	Durham	8,466,411 B2	6/2013	Arai
8,129,290 B2	3/2012	Balseanu et al.	8,470,187 B2	6/2013	Ha
8,137,462 B2	3/2012	Fondurulia et al.	8,484,846 B2	7/2013	Dhindsa
8,137,465 B1	3/2012	Shrinivasan et al.	8,492,170 B2	7/2013	Xie et al.
8,138,104 B2	3/2012	Balseanu et al.	8,496,377 B2	7/2013	Harr et al.
8,138,676 B2	3/2012	Mills	8,496,756 B2	7/2013	Cruse et al.
8,142,862 B2	3/2012	Lee et al.	8,497,213 B2	7/2013	Yasui et al.
8,143,174 B2	3/2012	Xia et al.	8,501,599 B2	8/2013	Ueno et al.
8,147,242 B2	4/2012	Shibagaki et al.	8,506,162 B2	8/2013	Schick et al.
8,158,512 B2	4/2012	Ji et al.	8,506,713 B2	8/2013	Takagi
8,172,947 B2	5/2012	Shibata et al.	8,529,701 B2	9/2013	Morita
8,173,554 B2	5/2012	Lee et al.	8,535,767 B1	9/2013	Kimura
8,178,436 B2	5/2012	King et al.	D691,974 S	10/2013	Osada et al.
8,187,679 B2	5/2012	Dickey et al.	8,551,892 B2	10/2013	Nakano
8,187,951 B1	5/2012	Wang	8,557,712 B1	10/2013	Antonelli et al.
8,192,901 B2	6/2012	Kageyama	8,562,272 B2	10/2013	Lenz
8,196,234 B2	6/2012	Glunk	8,563,443 B2	10/2013	Fukazawa
8,197,915 B2	6/2012	Oka et al.	8,569,184 B2	10/2013	Oka
8,198,168 B2	6/2012	Tanioku	D693,200 S	11/2013	Saunders
8,202,575 B2	6/2012	Monisma et al.	8,573,152 B2 *	11/2013	de la Llera H01R 13/20 118/723 E
8,206,506 B2 *	6/2012	Kadkhodayan H01J 37/3244 118/715	8,573,154 B2	11/2013	Yorozuya
8,216,380 B2	7/2012	White et al.	8,586,484 B2	11/2013	Matsuyama et al.
8,227,032 B2	7/2012	Dussarrat et al.	8,591,659 B1	11/2013	Fang et al.
8,231,799 B2	7/2012	Bera et al.	8,592,005 B2	11/2013	Ueda
D665,055 S	8/2012	Yanagisawa et al.	D694,790 S *	12/2013	Matsumoto D15/144
8,241,991 B2	8/2012	Hsieh et al.	D695,240 S	12/2013	Iida et al.
8,241,992 B2	8/2012	Clevenger et al.	8,608,885 B2	12/2013	Goto et al.
8,242,028 B1	8/2012	van Schravendijk	8,614,047 B2	12/2013	Ayothi et al.
8,242,031 B2	8/2012	Mallick et al.	8,616,765 B2	12/2013	Darabnia et al.
8,246,900 B2	8/2012	Kasai et al.	8,617,411 B2	12/2013	Singh
8,252,114 B2	8/2012	Vukovic	D697,038 S *	1/2014	Matsumoto D13/182
8,252,659 B2	8/2012	Huyghabaert et al.	8,633,115 B2	1/2014	Chang et al.
8,252,691 B2	8/2012	Beynet et al.	D698,904 S	2/2014	Milligan et al.
8,267,633 B2	9/2012	Obikane	8,642,488 B2	2/2014	Liu et al.
8,272,516 B2	9/2012	Salvador	8,647,439 B2	2/2014	Sanchez et al.
8,278,176 B2	10/2012	Bauer et al.	8,647,722 B2	2/2014	Kobayashi et al.
8,282,769 B2	10/2012	Iizuka	8,647,993 B2	2/2014	Lavoie et al.
8,282,847 B2	10/2012	Romano	8,651,788 B1	2/2014	Budde
8,287,648 B2	10/2012	Reed et al.	8,664,627 B1	3/2014	Ishikawa et al.
8,293,016 B2	10/2012	Bahng et al.	8,667,654 B2	3/2014	Gros-Jean
8,293,642 B2	10/2012	Kim	8,668,957 B2	3/2014	Dussarrat et al.
8,298,336 B2	10/2012	Wang et al.	8,669,185 B2	3/2014	Onizawa
8,298,951 B1	10/2012	Nakano	8,679,958 B2	3/2014	Takamure et al.
8,307,472 B1	11/2012	Saxon et al.	D702,188 S	4/2014	Jacobs
8,309,173 B2	11/2012	Tuominen et al.	8,683,943 B2	4/2014	Onodera et al.
8,318,327 B2	11/2012	O'Donnell	8,710,580 B2	4/2014	Sakuma et al.
8,323,413 B2	12/2012	Son	8,711,338 B2	4/2014	Liu et al.
			D705,745 S	5/2014	Kurs et al.
			D705,762 S	5/2014	Yu

(56)

References Cited

U.S. PATENT DOCUMENTS

8,664,127 B2	5/2014	Bhatia et al.	9,017,933 B2	4/2015	Liu et al.
8,720,965 B2	5/2014	Hino et al.	9,018,093 B2	4/2015	Tsuji et al.
8,721,791 B2	5/2014	Choi et al.	9,018,111 B2	4/2015	Milligan et al.
8,722,510 B2	5/2014	Watanabe et al.	9,018,567 B2	4/2015	de Ridder et al.
8,722,546 B2	5/2014	Fukazawa et al.	9,021,985 B2	5/2015	Alokozai et al.
8,726,837 B2	5/2014	Patalay et al.	9,023,737 B2	5/2015	Beynet et al.
8,728,832 B2	5/2014	Raisanen et al.	9,023,738 B2	5/2015	Kato et al.
8,728,956 B2	5/2014	Lavoie et al.	9,029,244 B2	5/2015	Won et al.
8,741,062 B2	6/2014	Lindfors et al.	9,029,253 B2	5/2015	Milligan et al.
8,742,668 B2	6/2014	Nakano et al.	9,029,272 B1	5/2015	Nakano
8,759,223 B2	6/2014	Sapre et al.	D732,145 S	6/2015	Yamagishi
D709,536 S	7/2014	Yoshimura et al.	D732,644 S	6/2015	Yamagishi et al.
D709,537 S	7/2014	Kuwabara et al.	D733,257 S *	6/2015	Schoenherr D23/213
8,764,085 B2	7/2014	Urabe	D733,261 S	6/2015	Yamagishi et al.
8,771,807 B2	7/2014	Xiao et al.	D733,262 S	6/2015	Kang
8,779,502 B2	7/2014	Sakuma et al.	9,057,388 B2	6/2015	Comeau et al.
8,784,950 B2	7/2014	Fukazawa et al.	9,064,815 B2	6/2015	Zhang et al.
8,784,951 B2	7/2014	Fukazawa et al.	D733,843 S	7/2015	Yamagishi
8,785,215 B2	7/2014	Kobayashi et al.	D734,377 S	7/2015	Hirakida
8,785,311 B2	7/2014	Miyoshi	9,076,635 B2	7/2015	Gross et al.
8,790,743 B1	7/2014	Omari	9,076,726 B2	7/2015	Kauerauf et al.
8,790,749 B2	7/2014	Omori et al.	D735,836 S	8/2015	Yamagishi et al.
8,802,201 B2	8/2014	Raisanen et al.	D736,348 S *	8/2015	Tan D23/213
8,809,170 B2	8/2014	Bauer	9,096,931 B2	8/2015	Yednak et al.
D712,358 S	9/2014	Allen et al.	9,099,423 B2	8/2015	Weeks et al.
D712,359 S	9/2014	Allen et al.	9,099,505 B2	8/2015	Kusakabe et al.
8,820,809 B2	9/2014	Ando et al.	9,111,972 B2	8/2015	Takeshita et al.
8,821,640 B2	9/2014	Cleary et al.	9,117,657 B2	8/2015	Nakano et al.
8,828,886 B2	9/2014	Samukawa et al.	9,117,866 B2	8/2015	Marquardt et al.
8,841,182 B1	9/2014	Chen et al.	D739,222 S	9/2015	Chadbourne
8,845,806 B2	9/2014	Aida et al.	9,123,510 B2	9/2015	Nakano et al.
8,846,502 B2	9/2014	Haukka et al.	9,123,577 B2	9/2015	Fujimoto et al.
D715,410 S	10/2014	Lohmann	9,127,358 B2	9/2015	Inoue et al.
8,859,368 B2	10/2014	Deniz	9,127,362 B2	9/2015	Scheible et al.
8,860,955 B2	10/2014	Rodnick et al.	9,129,897 B2	9/2015	Pore et al.
8,864,202 B1	10/2014	Schrameyer	9,136,108 B2	9/2015	Matsushita et al.
D716,742 S	11/2014	Jang et al.	9,136,180 B2	9/2015	Machkaoutsan
8,876,974 B2	11/2014	Wan	9,142,393 B2	9/2015	Okabe et al.
8,877,655 B2	11/2014	Shero et al.	9,142,437 B2	9/2015	Fosnight et al.
8,882,923 B2	11/2014	Saido et al.	9,153,441 B2	10/2015	Takamure et al.
8,883,270 B2	11/2014	Shero et al.	9,166,012 B2	10/2015	Sim et al.
8,900,999 B1	12/2014	Wu et al.	9,169,975 B2	10/2015	Sarin et al.
8,901,016 B2	12/2014	Jeongseok et al.	9,171,714 B2	10/2015	Mori
8,911,553 B2	12/2014	Baluja et al.	9,171,716 B2	10/2015	Fukuda
8,911,826 B2	12/2014	Adachi et al.	D742,202 S	11/2015	Cyphers et al.
8,912,101 B2	12/2014	Tsuji et al.	D743,357 S	11/2015	Vyne
D720,838 S	1/2015	Yamagishi et al.	D743,513 S	11/2015	Yamagishi
8,927,906 B2	1/2015	Tadokoro et al.	9,174,178 B2	11/2015	Berger et al.
8,933,375 B2	1/2015	Dunn et al.	9,175,394 B2	11/2015	Yudovsky et al.
8,940,646 B1	1/2015	Chandrasekharan	9,177,784 B2	11/2015	Raisanen et al.
D723,153 S	2/2015	Borkholder	9,184,047 B2	11/2015	Liu et al.
8,945,305 B2	2/2015	Marsh	9,184,054 B1	11/2015	Huang et al.
8,945,306 B2	2/2015	Tsuda	9,190,263 B2	11/2015	Ishikawa et al.
8,945,339 B2	2/2015	Kakimoto	9,190,264 B2	11/2015	Yuasa et al.
8,946,830 B2	2/2015	Jung et al.	9,196,483 B1	11/2015	Lee et al.
8,956,971 B2	2/2015	Huakka	D745,641 S *	12/2015	Blum D23/249
8,956,983 B2	2/2015	Swaminathan	9,202,727 B2	12/2015	Dunn et al.
D723,330 S	3/2015	York	9,214,333 B1	12/2015	Sims et al.
D724,553 S	3/2015	Choi	9,228,259 B2	1/2016	Haukka et al.
D724,701 S	3/2015	Yamagishi et al.	9,240,412 B2	1/2016	Xie et al.
D725,168 S	3/2015	Yamagishi	9,245,742 B2	1/2016	Haukka
8,967,608 B2	3/2015	Mitsumori et al.	9,252,024 B2	2/2016	Lam et al.
8,974,868 B2	3/2015	Ishikawa et al.	9,252,238 B1	2/2016	Trevino et al.
8,980,006 B2	3/2015	Huh et al.	9,257,274 B2	2/2016	Kang et al.
8,986,456 B2	3/2015	Fondurulia et al.	9,263,298 B2	2/2016	Matsumoto et al.
8,991,214 B2	3/2015	Hoshino et al.	9,267,204 B2	2/2016	Honma
8,991,887 B2	3/2015	Shin et al.	9,267,850 B2	2/2016	Aggarwal
8,993,054 B2	3/2015	Jung et al.	D751,176 S *	3/2016	Schoenherr D23/213
8,993,457 B1	3/2015	Ramkumar et al.	9,275,834 B1	3/2016	Park et al.
D726,365 S	4/2015	Weigensberg	9,281,277 B2	3/2016	Baek et al.
D726,884 S	4/2015	Yamagishi et al.	9,284,642 B2	3/2016	Nakano
8,999,102 B2	4/2015	Miyoshi et al.	9,287,273 B2	3/2016	Ragnarsson et al.
9,004,744 B1	4/2015	Kemp	9,297,705 B2	3/2016	Aggarwal
9,005,539 B2	4/2015	Halpin et al.	9,299,557 B2	3/2016	Tolle et al.
9,017,481 B1	4/2015	Pettinger et al.	9,299,595 B2	3/2016	Dunn et al.
			D753,269 S	4/2016	Yamagishi et al.
			D753,629 S	4/2016	Plattard
			9,305,836 B1	4/2016	Gates et al.
			9,309,598 B2	4/2016	Wang et al.

(56)

References Cited

U.S. PATENT DOCUMENTS

9,309,978 B2	4/2016	Hatch et al.	D787,458 S	5/2017	Kim et al.
9,312,155 B2	4/2016	Mori	9,640,416 B2	5/2017	Arai
9,315,897 B2	4/2016	Byun	9,640,448 B2	5/2017	Ikegawa et al.
9,324,811 B2	4/2016	Weeks	9,640,542 B2	5/2017	Lee et al.
9,324,846 B1	4/2016	Camillo	9,644,266 B2	5/2017	Nasu et al.
D756,929 S	5/2016	Harck et al.	9,647,114 B2	5/2017	Margetis
9,331,200 B1	5/2016	Wang et al.	9,657,845 B2	5/2017	Shugrue
9,337,054 B2	5/2016	Hunks et al.	9,659,799 B2	5/2017	Lawson
9,337,057 B2	5/2016	Park et al.	9,663,857 B2	5/2017	Nakano et al.
9,341,296 B2	5/2016	Yednak	9,666,528 B1	5/2017	Bergendahl et al.
9,343,297 B1	5/2016	Fukazawa et al.	D789,888 S	6/2017	Jang et al.
9,343,308 B2	5/2016	Isii	D790,041 S	6/2017	Jang et al.
9,343,343 B2	5/2016	Mori	9,680,268 B1	6/2017	Finona
9,343,350 B2	5/2016	Arai	9,684,234 B2	6/2017	Darling et al.
9,349,620 B2	5/2016	Kamata et al.	9,685,320 B2	6/2017	Kang et al.
9,353,440 B2	5/2016	Ge et al.	9,691,668 B2	6/2017	Chang et al.
9,353,441 B2	5/2016	Chung	9,691,771 B2	6/2017	Lansalot-Matras
9,355,876 B2	5/2016	Reuter et al.	9,698,031 B2	7/2017	Kobayashi et al.
9,355,882 B2	5/2016	Wu et al.	9,708,707 B2	7/2017	Ditizio et al.
D759,137 S	6/2016	Hassan	9,708,708 B2	7/2017	Isobe et al.
9,362,107 B2	6/2016	Thadani et al.	9,711,345 B2	7/2017	Shiba et al.
9,362,137 B2	6/2016	Kang et al.	D793,352 S	8/2017	Hill
9,362,180 B2	6/2016	Lee et al.	D793,572 S	8/2017	Kozuka et al.
9,365,924 B2	6/2016	Nonaka	D793,976 S	8/2017	Fukushima et al.
9,368,352 B2	6/2016	Takamure et al.	D795,208 S	8/2017	Sasaki et al.
9,370,863 B2	6/2016	Tsuji et al.	9,735,024 B2	8/2017	Zaitso
9,378,969 B2	6/2016	Hsu et al.	9,741,546 B2	8/2017	Carducci et al.
9,384,987 B2	7/2016	Jung et al.	9,741,559 B2	8/2017	Shimura et al.
9,390,909 B2	7/2016	Pasquale et al.	9,745,658 B2	8/2017	Kang et al.
9,394,608 B2	7/2016	Shero et al.	9,748,145 B1	8/2017	Kannan et al.
9,396,934 B2	7/2016	Tolle	D796,458 S	9/2017	Jang et al.
9,396,956 B1	7/2016	Fukazawa	D796,670 S	9/2017	Dolk et al.
9,399,228 B2	7/2016	Breiling et al.	9,754,779 B1	9/2017	Ishikawa
D764,196 S	8/2016	Handler et al.	9,754,818 B2	9/2017	Shiu et al.
9,404,587 B2	8/2016	Shugrue	9,759,489 B2	9/2017	Kaneko
9,412,564 B2	8/2016	Milligan	9,765,432 B2	9/2017	Ge et al.
9,412,581 B2	8/2016	Thadani et al.	9,786,491 B2	10/2017	Suzuki et al.
9,412,582 B2	8/2016	Sasaki et al.	9,790,595 B2	10/2017	Jung et al.
9,418,885 B2	8/2016	Sung et al.	9,793,115 B2	10/2017	Tolle
9,425,078 B2	8/2016	Tang et al.	9,793,135 B1	10/2017	Zaitso et al.
9,443,725 B2	9/2016	Liu et al.	9,793,148 B2	10/2017	Yamagishi et al.
9,447,498 B2	9/2016	Shiba et al.	9,798,308 B2	10/2017	Mimura
9,449,793 B2	9/2016	Shaji et al.	9,799,736 B1	10/2017	Ebrish et al.
9,455,138 B1	9/2016	Fukazawa	D802,546 S	11/2017	Jang et al.
9,455,177 B1	9/2016	Park et al.	9,808,246 B2	11/2017	Shelton et al.
9,464,352 B2	10/2016	Nakano et al.	9,812,319 B1	11/2017	Fukazawa et al.
9,474,163 B2	10/2016	Tolle et al.	9,812,320 B1	11/2017	Pore et al.
9,478,414 B2	10/2016	Kobayashi et al.	9,820,289 B1	11/2017	Pawar et al.
9,478,415 B2	10/2016	Kimura	9,824,893 B1	11/2017	Smith et al.
D770,993 S	11/2016	Yoshida et al.	9,847,221 B1	12/2017	McLaughlin et al.
9,484,191 B2	11/2016	Winkler	D808,254 S	1/2018	Deleu
9,496,225 B1	11/2016	Adusumilli et al.	9,859,151 B1	1/2018	Niskanen
9,514,927 B2	12/2016	Tolle et al.	9,865,455 B1	1/2018	Sims et al.
9,514,932 B2	12/2016	Mallick et al.	9,865,456 B1	1/2018	Pandey et al.
9,520,289 B2	12/2016	Park et al.	9,865,815 B2	1/2018	Hausmann
9,523,148 B1	12/2016	Pore et al.	9,868,131 B2	1/2018	Kilpi et al.
D777,546 S	1/2017	Ishii et al.	9,870,964 B1	1/2018	Yoshino et al.
9,543,180 B2	1/2017	Kamiya	9,875,891 B2	1/2018	Henri et al.
9,556,516 B2	1/2017	Takamure	9,875,893 B2	1/2018	Takamure et al.
9,558,931 B2	1/2017	Tang	D810,705 S	2/2018	Krishnan et al.
9,564,312 B2	2/2017	Henri et al.	9,887,082 B1	2/2018	Pore et al.
9,564,314 B2	2/2017	Takamure et al.	9,890,456 B2	2/2018	Tolle et al.
9,570,302 B1	2/2017	Chang et al.	9,891,521 B2	2/2018	Kang et al.
9,574,268 B1	2/2017	Dunn et al.	9,892,908 B2	2/2018	Pettinger et al.
9,576,952 B2	2/2017	Joshi et al.	9,892,913 B2	2/2018	Margetis et al.
9,583,345 B2	2/2017	Chen et al.	9,895,715 B2	2/2018	Haukka et al.
D782,419 S	3/2017	Willette	9,899,291 B2	2/2018	Kato
9,589,770 B2	3/2017	Winkler	9,899,405 B2	2/2018	Kim
9,605,342 B2	3/2017	Alokozai et al.	9,905,420 B2	2/2018	Margetis et al.
9,605,343 B2	3/2017	Winkler	9,905,492 B2	2/2018	Tang et al.
9,607,837 B1	3/2017	Namba	9,909,492 B2	2/2018	Tang
D783,351 S	4/2017	Fujino et al.	9,909,214 B2	3/2018	Suemori
9,613,801 B2	4/2017	Carcasi et al.	9,911,676 B2	3/2018	Tang
9,627,221 B1	4/2017	Zaitso et al.	9,916,980 B1	3/2018	Knaepen
D785,766 S	5/2017	Sato	9,929,011 B2	3/2018	Hawryluk et al.
			9,951,421 B2	4/2018	Lind
			9,960,033 B1	5/2018	Nozawa
			9,960,072 B2	5/2018	Coomer
			9,966,299 B2	5/2018	Tang et al.

(56)

References Cited

U.S. PATENT DOCUMENTS

9,984,869 B1	5/2018	Blanquart	2001/0001953 A1	5/2001	Griffiths et al.
D819,580 S	6/2018	Krishnan et al.	2001/0003015 A1	6/2001	Chang et al.
9,987,747 B2	6/2018	Hwang et al.	2001/0003191 A1	6/2001	Kovacs et al.
9,997,357 B2	6/2018	Arghavani et al.	2001/0004880 A1	6/2001	Cho et al.
9,997,373 B2	6/2018	Hudson	2001/0006070 A1	7/2001	Shang
10,032,628 B2	6/2018	Xie et al.	2001/0007645 A1	7/2001	Honma
10,018,920 B2	7/2018	Chang et al.	2001/0014267 A1	8/2001	Yamaga et al.
10,023,960 B2	7/2018	Alokozai	2001/0014514 A1	8/2001	Geusic
10,032,792 B2	7/2018	Kim et al.	2001/0016273 A1	8/2001	Narasimhan et al.
10,043,661 B2	8/2018	Kato et al.	2001/0017103 A1	8/2001	Takeshita et al.
10,047,435 B2	8/2018	Haukka et al.	2001/0018267 A1	8/2001	Shinriki et al.
10,053,774 B2	8/2018	Tolle et al.	2001/0019777 A1	9/2001	Tanaka et al.
10,060,473 B2	8/2018	Davey et al.	2001/0019900 A1	9/2001	Hasegawa
D827,592 S	9/2018	Ichino et al.	2001/0020715 A1	9/2001	Yamasaki
10,083,836 B2	9/2018	Milligan	2001/0028924 A1	10/2001	Sherman
D830,981 S	10/2018	Jeong et al.	2001/0031535 A1	10/2001	Agnello et al.
10,087,522 B2	10/2018	Raisanen et al.	2001/0031541 A1	10/2001	Madan et al.
10,087,525 B2	10/2018	Schmotzer et al.	2001/0034097 A1	10/2001	Lim et al.
10,090,316 B2	10/2018	Ootsuka	2001/0038783 A1	11/2001	Nakashima et al.
10,103,040 B1	10/2018	Oosterlaken et al.	2001/0039922 A1	11/2001	Nakahara
10,106,892 B1	10/2018	Siddiqui et al.	2001/0039966 A1	11/2001	Walpole et al.
RE47,145 E	11/2018	Hashimoto	2001/0040511 A1	11/2001	Bushner et al.
10,121,671 B2	11/2018	Fu et al.	2001/0041250 A1	11/2001	Werkhoven et al.
10,134,617 B2	11/2018	Gurary et al.	2001/0042511 A1	11/2001	Liu et al.
10,134,757 B2	11/2018	Chun et al.	2001/0046765 A1	11/2001	Cappellani et al.
RE47,170 E	12/2018	Beynet et al.	2001/0048981 A1	12/2001	Suzuki
10,147,600 B2	12/2018	Takamure et al.	2001/0049080 A1	12/2001	Asano
10,167,557 B2	1/2019	Hawkins et al.	2001/0049202 A1	12/2001	Maeda et al.
10,177,024 B2	1/2019	Gomm et al.	2001/0054388 A1	12/2001	Qian
10,177,025 B2	1/2019	Pore	2002/0000195 A1	1/2002	Bang et al.
10,179,947 B2	1/2019	Fukazawa	2002/0000202 A1	1/2002	Yuda et al.
10,186,420 B2	1/2019	Fukazawa	2002/0001974 A1	1/2002	Chan
10,190,213 B2	1/2019	Zhu et al.	2002/0001976 A1	1/2002	Danek
10,190,214 B2	1/2019	Shon et al.	2002/0005400 A1	1/2002	Gat et al.
10,190,701 B2	1/2019	Raj et al.	2002/0008270 A1	1/2002	Marsh
10,193,429 B2	1/2019	Smith et al.	2002/0009119 A1	1/2002	Matthew et al.
D840,364 S	2/2019	Ichino et al.	2002/0009560 A1	1/2002	Ozono
10,211,308 B2	2/2019	Zhu et al.	2002/0009861 A1	1/2002	Narwankar et al.
10,229,833 B2	3/2019	Raisanen et al.	2002/0011210 A1	1/2002	Satoh et al.
10,236,177 B1	3/2019	Kohen et al.	2002/0011211 A1	1/2002	Halpin
10,249,524 B2	4/2019	den Hartog Besselink et al.	2002/0011310 A1	1/2002	Kamarehi et al.
10,249,577 B2	4/2019	Lee et al.	2002/0013792 A1	1/2002	Imielinski et al.
10,262,859 B2	4/2019	Margetis et al.	2002/0014204 A1	2/2002	Pyo
10,269,558 B2	4/2019	Blanquart et al.	2002/0014483 A1	2/2002	Suzuki et al.
10,276,355 B2	4/2019	White et al.	2002/0016829 A1	2/2002	Defosse
D849,662 S	5/2019	Rike	2002/0020429 A1	2/2002	Selbrede et al.
10,283,353 B2	5/2019	Kobayashi et al.	2002/0023677 A1	2/2002	Zheng
10,290,508 B1	5/2019	Kubota et al.	2002/0025688 A1	2/2002	Kato
RE47,440 E	6/2019	Yudovsky et al.	2002/0027945 A1	3/2002	Hirano et al.
10,312,055 B2	6/2019	Suzuki	2002/0030047 A1	3/2002	Shao et al.
10,312,129 B2	6/2019	Coomer	2002/0031644 A1	3/2002	Malofsky et al.
10,319,588 B2	6/2019	Mattinen et al.	2002/0041931 A1	4/2002	Suntola et al.
10,322,384 B2	6/2019	Stumpf et al.	2002/0043337 A1	4/2002	Goodman et al.
D855,089 S	7/2019	Hopkins	2002/0048634 A1	4/2002	Basceri
10,340,125 B2	7/2019	Winkler	2002/0050648 A1	5/2002	Kishida et al.
10,340,135 B2	7/2019	Blanquart	2002/0062633 A1	5/2002	Denker et al.
10,343,920 B2	7/2019	Haukka	2002/0064592 A1	5/2002	Dana et al.
10,347,547 B2	7/2019	Varadarajan et al.	2002/0064598 A1	5/2002	Wang et al.
10,361,201 B2	7/2019	Xie et al.	2002/0066532 A1	6/2002	Shih et al.
10,367,080 B2	7/2019	Tang et al.	2002/0069222 A1	6/2002	McNeely
10,388,513 B1	8/2019	Blanquart	2002/0073922 A1	6/2002	Frankel et al.
10,395,917 B2	8/2019	Niskanen et al.	2002/0076490 A1	6/2002	Chiang et al.
10,395,919 B2	8/2019	Masaru et al.	2002/0076507 A1	6/2002	Chiang et al.
D859,136 S	9/2019	Tenander et al.	2002/0076944 A1	6/2002	Wang et al.
10,400,335 B2	9/2019	Ge et al.	2002/0078893 A1	6/2002	Van Os et al.
10,428,419 B2	10/2019	Huotari et al.	2002/0079714 A1	6/2002	Soucy et al.
10,435,790 B2	10/2019	Fukazawa et al.	2002/0081826 A1	6/2002	Rotondaro et al.
D867,867 S	11/2019	Tenander et al.	2002/0086501 A1	7/2002	O'Donnell et al.
10,468,244 B2	11/2019	Li et al.	2002/0088542 A1	7/2002	Nishikawa et al.
10,468,251 B2	11/2019	Ishikawa et al.	2002/0090735 A1	7/2002	Kishkovich et al.
10,483,154 B1	11/2019	Smith et al.	2002/0094378 A1	7/2002	O'Donnell et al.
10,529,554 B2	1/2020	Ishikawa et al.	2002/0096211 A1	7/2002	Zheng
D876,504 S	2/2020	Lee et al.	2002/0098627 A1	7/2002	Pomarede et al.
D880,437 S *	4/2020	Lee	2002/0099470 A1	7/2002	Zinger et al.
2001/0000141 A1	4/2001	Zhou et al.	2002/0100418 A1	8/2002	Sandhu et al.
			2002/0104751 A1	8/2002	Drewery et al.
			2002/0108670 A1	8/2002	Baker et al.
			2002/0108714 A1	8/2002	Doering et al.
			2002/0109115 A1	8/2002	Cederstav et al.

D13/182

(56)

References Cited

U.S. PATENT DOCUMENTS

2002/0110695	A1	8/2002	Yang et al.	2003/0049372	A1	3/2003	Cook et al.
2002/0110991	A1	8/2002	Li	2003/0049375	A1	3/2003	Nguyen et al.
2002/0112114	A1	8/2002	Blair et al.	2003/0049499	A1	3/2003	Murakawa et al.
2002/0114886	A1	8/2002	Chou et al.	2003/0049937	A1	3/2003	Suzuki
2002/0115252	A1	8/2002	Haukka et al.	2003/0054670	A1	3/2003	Wang et al.
2002/0117113	A1	8/2002	Tsuruno et al.	2003/0057848	A1	3/2003	Yuasa et al.
2002/0122885	A1	9/2002	Aim	2003/0059535	A1	3/2003	Luo et al.
2002/0123200	A1	9/2002	Yamamoto et al.	2003/0059980	A1	3/2003	Chen et al.
2002/0123230	A1	9/2002	Hubacek	2003/0062359	A1	4/2003	Ho et al.
2002/0123237	A1	9/2002	Nguyen et al.	2003/0065413	A1	4/2003	Liteplo et al.
2002/0124883	A1	9/2002	Zheng	2003/0066482	A1	4/2003	Pokharna et al.
2002/0124906	A1	9/2002	Suzuki et al.	2003/0066541	A1	4/2003	Sun et al.
2002/0127350	A1	9/2002	Ishikawa et al.	2003/0066826	A1	4/2003	Lee et al.
2002/0132408	A1	9/2002	Ma et al.	2003/0070617	A1	4/2003	Kim et al.
2002/0134511	A1	9/2002	Ushioda et al.	2003/0071015	A1	4/2003	Chinn et al.
2002/0136214	A1	9/2002	Do et al.	2003/0072882	A1	4/2003	Niinisto et al.
2002/0136909	A1	9/2002	Yang	2003/0075925	A1	4/2003	Lindfors et al.
2002/0139775	A1	10/2002	Chang	2003/0077857	A1	4/2003	Xia et al.
2002/0146512	A1	10/2002	Rossmann	2003/0077883	A1	4/2003	Ohtake
2002/0151327	A1	10/2002	Levitt	2003/0082296	A1	5/2003	Elers et al.
2002/0152244	A1	10/2002	Dean et al.	2003/0082307	A1	5/2003	Chung et al.
2002/0155219	A1	10/2002	Wang et al.	2003/0085663	A1	5/2003	Horsky
2002/0155708	A1	10/2002	Lo et al.	2003/0091938	A1	5/2003	Fairbairn et al.
2002/0157611	A1	10/2002	Bondestam et al.	2003/0094133	A1	5/2003	Yoshidome et al.
2002/0160112	A1	10/2002	Sakai et al.	2003/0101938	A1	6/2003	Ronsse et al.
2002/0164420	A1	11/2002	Derderian et al.	2003/0109107	A1	6/2003	Hsieh et al.
2002/0168870	A1	11/2002	Matsuki	2003/0109951	A1	6/2003	Hsiung et al.
2002/0172768	A1	11/2002	Endo et al.	2003/0111013	A1	6/2003	Oosterlaken et al.
2002/0174106	A1	11/2002	Martin	2003/0111963	A1	6/2003	Tolmachev et al.
2002/0179011	A1	12/2002	Jonnalagadda et al.	2003/0116087	A1	6/2003	Nguyen
2002/0184111	A1	12/2002	Swanson	2003/0121608	A1	7/2003	Chen
2002/0187650	A1	12/2002	Blalock et al.	2003/0124792	A1	7/2003	Jeon et al.
2002/0187656	A1	12/2002	Tan et al.	2003/0124820	A1	7/2003	Johnsgard et al.
2002/0188376	A1	12/2002	Derderian et al.	2003/0124842	A1	7/2003	Hytros et al.
2002/0192370	A1	12/2002	Metzner et al.	2003/0127049	A1	7/2003	Han et al.
2002/0197849	A1	12/2002	Mandal	2003/0133854	A1	7/2003	Tabata et al.
2003/0000647	A1	1/2003	Yudovsky et al.	2003/0134038	A1	7/2003	Paranjpe
2003/0002562	A1	1/2003	Yerlikaya et al.	2003/0140851	A1	7/2003	Janakiraman et al.
2003/0003607	A1	1/2003	Kagoshima	2003/0141820	A1	7/2003	White et al.
2003/0003635	A1	1/2003	Paranjpe et al.	2003/0143328	A1	7/2003	Chen
2003/0003696	A1	1/2003	Gelatos et al.	2003/0149506	A1	8/2003	Haanstra et al.
2003/0003719	A1	1/2003	Lim et al.	2003/0153177	A1	8/2003	Tepman et al.
2003/0008528	A1	1/2003	Xia et al.	2003/0153186	A1	8/2003	Bar-Gadda
2003/0010355	A1	1/2003	Nowak et al.	2003/0157432	A1	8/2003	Rottsegge
2003/0010451	A1	1/2003	Tzu	2003/0157436	A1	8/2003	Manger et al.
2003/0010452	A1	1/2003	Park et al.	2003/0159656	A1	8/2003	Tan
2003/0012632	A1	1/2003	Saeki	2003/0162412	A1	8/2003	Chung
2003/0015141	A1	1/2003	Takagi	2003/0168001	A1	9/2003	Sneh
2003/0015294	A1	1/2003	Wang	2003/0168008	A1	9/2003	Ohmi et al.
2003/0015596	A1	1/2003	Evans	2003/0168012	A1	9/2003	Tamura et al.
2003/0017265	A1	1/2003	Basceri et al.	2003/0168699	A1	9/2003	Honda
2003/0017266	A1	1/2003	Basceri et al.	2003/0168750	A1	9/2003	Basceri et al.
2003/0017268	A1	1/2003	Hu	2003/0168948	A1	9/2003	Yamagishi et al.
2003/0019428	A1	1/2003	Ku et al.	2003/0170153	A1	9/2003	Bar-Gadda
2003/0019580	A1	1/2003	Strang	2003/0170583	A1	9/2003	Nakashima
2003/0022468	A1	1/2003	Shioya et al.	2003/0170945	A1	9/2003	Igeta et al.
2003/0022523	A1	1/2003	Irino et al.	2003/0173030	A1	9/2003	Ishii et al.
2003/0023338	A1	1/2003	Chin et al.	2003/0173490	A1	9/2003	Lappen
2003/0024901	A1	2/2003	Ishikawa	2003/0176074	A1	9/2003	Paterson et al.
2003/0025146	A1	2/2003	Narwankar et al.	2003/0178145	A1	9/2003	Anderson et al.
2003/0027431	A1	2/2003	Sneh et al.	2003/0180458	A1	9/2003	Sneh
2003/0029303	A1	2/2003	Hasegawa et al.	2003/0183156	A1	10/2003	Dando
2003/0029381	A1	2/2003	Nishibayashi	2003/0183856	A1	10/2003	Wieczorek et al.
2003/0029475	A1	2/2003	Hua et al.	2003/0188685	A1	10/2003	Wang
2003/0035002	A1	2/2003	Moles	2003/0190804	A1	10/2003	Glenn et al.
2003/0035705	A1	2/2003	Johnson	2003/0192875	A1	10/2003	Bieker et al.
2003/0036272	A1	2/2003	Shamouilian et al.	2003/0198587	A1	10/2003	Kaloyeros
2003/0037800	A1	2/2003	Bailey et al.	2003/0201541	A1	10/2003	Kim
2003/0040120	A1	2/2003	Allen et al.	2003/0205202	A1	11/2003	Funaki et al.
2003/0040158	A1	2/2003	Saitoh	2003/0205327	A1	11/2003	Howald et al.
2003/0040196	A1	2/2003	Lim et al.	2003/0207032	A1	11/2003	Ahn et al.
2003/0040841	A1	2/2003	Nasr et al.	2003/0209323	A1	11/2003	Yokogaki
2003/0041971	A1	3/2003	Kido et al.	2003/0209326	A1	11/2003	Lee et al.
2003/0042419	A1	3/2003	Katsumata et al.	2003/0209746	A1	11/2003	Horii
2003/0045961	A1	3/2003	Nakao	2003/0210901	A1	11/2003	Donald et al.
				2003/0211735	A1	11/2003	Rossmann
				2003/0213435	A1	11/2003	Okuda et al.
				2003/0213560	A1	11/2003	Wang et al.
				2003/0213562	A1	11/2003	Gondhalekar et al.

(56)

References Cited

U.S. PATENT DOCUMENTS

2003/0215963	A1	11/2003	AmRhein et al.	2004/0142577	A1	7/2004	Sugawara et al.
2003/0217915	A1	11/2003	Ouellet	2004/0144311	A1	7/2004	Chen
2003/0219972	A1	11/2003	Green	2004/0144323	A1	7/2004	Kai
2003/0226840	A1	12/2003	Dalton	2004/0144980	A1	7/2004	Ahn et al.
2003/0228772	A1	12/2003	Cowans	2004/0146644	A1	7/2004	Xia et al.
2003/0230986	A1	12/2003	Horsky et al.	2004/0151844	A1	8/2004	Zhang et al.
2003/0231698	A1	12/2003	Yamaguchi	2004/0151845	A1	8/2004	Nguyen et al.
2003/0232138	A1	12/2003	Tuominen et al.	2004/0152287	A1	8/2004	Sherrill et al.
2003/0232491	A1	12/2003	Yamaguchi	2004/0159343	A1	8/2004	Shimbara et al.
2003/0232511	A1	12/2003	Metzner et al.	2004/0168627	A1	9/2004	Conley et al.
2003/0234371	A1	12/2003	Ziegler	2004/0168742	A1	9/2004	Kim et al.
2004/0002224	A1	1/2004	Chono et al.	2004/0168769	A1	9/2004	Matsuoka et al.
2004/0005147	A1	1/2004	Wang et al.	2004/0169032	A1	9/2004	Murayama et al.
2004/0009307	A1	1/2004	Koh et al.	2004/0185177	A1	9/2004	Basceri et al.
2004/0009679	A1	1/2004	Yeo et al.	2004/0187304	A1	9/2004	Chen et al.
2004/0010772	A1	1/2004	McKenna et al.	2004/0187777	A1	9/2004	Okamoto et al.
2004/0011504	A1	1/2004	Ku et al.	2004/0187784	A1	9/2004	Sferlazzo
2004/0013577	A1	1/2004	Ganguli et al.	2004/0187790	A1	9/2004	Bader
2004/0013818	A1	1/2004	Moon et al.	2004/0187928	A1	9/2004	Ambrosina
2004/0015300	A1	1/2004	Ganguli et al.	2004/0198069	A1	10/2004	Metzner et al.
2004/0016637	A1	1/2004	Yang	2004/0200499	A1	10/2004	Harvey et al.
2004/0018304	A1	1/2004	Chung et al.	2004/0202786	A1	10/2004	Wongsenakhum et al.
2004/0018307	A1	1/2004	Park et al.	2004/0203251	A1	10/2004	Kawaguchi et al.
2004/0018723	A1	1/2004	Byun et al.	2004/0206305	A1	10/2004	Choi et al.
2004/0018750	A1	1/2004	Sophie et al.	2004/0209477	A1	10/2004	Buxbaum et al.
2004/0023516	A1	2/2004	Londergan et al.	2004/0211357	A1	10/2004	Gadgil
2004/0025787	A1	2/2004	Selbrede et al.	2004/0212947	A1	10/2004	Nguyen
2004/0026372	A1	2/2004	Takenaka et al.	2004/0213921	A1	10/2004	Leu
2004/0029052	A1	2/2004	Park et al.	2004/0214399	A1	10/2004	Ahn et al.
2004/0031564	A1	2/2004	Gottscho et al.	2004/0214445	A1	10/2004	Shimizu et al.
2004/0035358	A1	2/2004	Basceri et al.	2004/0217217	A1	11/2004	Han et al.
2004/0036129	A1	2/2004	Forbes et al.	2004/0219793	A1	11/2004	Hishiya et al.
2004/0037675	A1	2/2004	Zinger et al.	2004/0220699	A1	11/2004	Heden et al.
2004/0038525	A1	2/2004	Meng et al.	2004/0221807	A1	11/2004	Verghese et al.
2004/0043149	A1	3/2004	Gordon et al.	2004/0221808	A1	11/2004	Kawano
2004/0043544	A1	3/2004	Asai et al.	2004/0223893	A1	11/2004	Tabata et al.
2004/0048439	A1	3/2004	Soman	2004/0228968	A1	11/2004	Basceri
2004/0048452	A1	3/2004	Sugawara et al.	2004/0231600	A1	11/2004	Lee
2004/0048492	A1	3/2004	Ishikawa et al.	2004/0238523	A1	12/2004	Kuibira et al.
2004/0050325	A1	3/2004	Samoilov	2004/0241322	A1	12/2004	Basceri et al.
2004/0050496	A1	3/2004	Iwai et al.	2004/0241998	A1	12/2004	Hanson
2004/0056017	A1	3/2004	Renken	2004/0247779	A1	12/2004	Selvamanickam et al.
2004/0062081	A1	4/2004	Drewes	2004/0250600	A1	12/2004	Bevers et al.
2004/0063289	A1	4/2004	Ohta	2004/0253867	A1	12/2004	Matsumoto
2004/0065255	A1	4/2004	Yang et al.	2004/0261492	A1	12/2004	Zarkar et al.
2004/0069226	A1	4/2004	Yoshida et al.	2004/0261712	A1	12/2004	Hayashi et al.
2004/0071897	A1	4/2004	Verplancken et al.	2004/0261946	A1	12/2004	Endoh et al.
2004/0077182	A1	4/2004	Lim et al.	2004/0266011	A1	12/2004	Lee et al.
2004/0079960	A1	4/2004	Shakuda	2005/0000428	A1	1/2005	Shero et al.
2004/0080697	A1	4/2004	Song	2005/0003089	A1	1/2005	Won et al.
2004/0082171	A1	4/2004	Shin et al.	2005/0003600	A1	1/2005	Kasai et al.
2004/0083961	A1	5/2004	Basceri	2005/0003662	A1	1/2005	Jurisch et al.
2004/0083964	A1	5/2004	Ingle et al.	2005/0008799	A1	1/2005	Tomiyasu et al.
2004/0083975	A1	5/2004	Tong et al.	2005/0009325	A1	1/2005	Chung et al.
2004/0087141	A1	5/2004	Ramanathan et al.	2005/0016470	A1	1/2005	Kang et al.
2004/0089236	A1	5/2004	Yokogawa et al.	2005/0016956	A1	1/2005	Liu et al.
2004/0092073	A1	5/2004	Cabral et al.	2005/0017272	A1	1/2005	Yamashita et al.
2004/0092120	A1	5/2004	Wicker	2005/0019026	A1	1/2005	Wang et al.
2004/0094206	A1	5/2004	Ishida	2005/0019494	A1	1/2005	Moghadam et al.
2004/0094402	A1	5/2004	Gopalraja	2005/0020071	A1	1/2005	Sonobe et al.
2004/0099213	A1	5/2004	Adomaitis et al.	2005/0023624	A1	2/2005	Ahn et al.
2004/0101622	A1	5/2004	Park et al.	2005/0026402	A1	2/2005	Jurgensen
2004/0103914	A1	6/2004	Cheng et al.	2005/0033075	A1	2/2005	Chi et al.
2004/0105738	A1	6/2004	Ahn et al.	2005/0034664	A1	2/2005	Koh et al.
2004/0106249	A1	6/2004	Huotari	2005/0034674	A1	2/2005	Ono
2004/0115936	A1	6/2004	DePetrillo et al.	2005/0037154	A1	2/2005	Koh et al.
2004/0121620	A1	6/2004	Pomarede et al.	2005/0037578	A1	2/2005	Chen et al.
2004/0124131	A1	7/2004	Aitchison	2005/0037610	A1	2/2005	Cha
2004/0124549	A1	7/2004	Curran	2005/0040144	A1	2/2005	Sellers
2004/0126213	A1	7/2004	Pelzmann et al.	2005/0042778	A1	2/2005	Peukert
2004/0126990	A1	7/2004	Ohta	2005/0046825	A1	3/2005	Powell et al.
2004/0127069	A1	7/2004	Yamazaki et al.	2005/0048797	A1	3/2005	Fukazawa
2004/0129211	A1	7/2004	Blonigan et al.	2005/0051093	A1	3/2005	Makino et al.
2004/0129671	A1	7/2004	Ji et al.	2005/0051100	A1	3/2005	Chiang et al.
2004/0134429	A1	7/2004	Yamanaka	2005/0054228	A1	3/2005	March
				2005/0056218	A1	3/2005	Sun et al.
				2005/0056780	A1	3/2005	Miller et al.
				2005/0059261	A1	3/2005	Basceri et al.
				2005/0059262	A1	3/2005	Yin et al.

(56)

References Cited

U.S. PATENT DOCUMENTS

2005/0059264	A1	3/2005	Cheung	2005/0233477	A1	10/2005	Yamazaki et al.
2005/0061964	A1	3/2005	Nagano et al.	2005/0238807	A1	10/2005	Lin et al.
2005/0064207	A1	3/2005	Senzaki et al.	2005/0241176	A1	11/2005	Shero et al.
2005/0064719	A1	3/2005	Liu	2005/0241763	A1	11/2005	Huang et al.
2005/0066893	A1	3/2005	Soininen	2005/0241765	A1	11/2005	Dhindsa et al.
2005/0069651	A1	3/2005	Miyoshi	2005/0245058	A1	11/2005	Lee et al.
2005/0070123	A1	3/2005	Hirano	2005/0249876	A1	11/2005	Kawahara et al.
2005/0070128	A1	3/2005	Xia et al.	2005/0250340	A1	11/2005	Chen et al.
2005/0070729	A1	3/2005	Kiyomori et al.	2005/0251990	A1	11/2005	Choi
2005/0072357	A1	4/2005	Shero et al.	2005/0252447	A1	11/2005	Zhao et al.
2005/0074576	A1	4/2005	Chaiken et al.	2005/0252449	A1	11/2005	Nguyen et al.
2005/0074983	A1	4/2005	Shinriki et al.	2005/0252455	A1	11/2005	Moriya et al.
2005/0079124	A1	4/2005	Sanderson	2005/0253061	A1	11/2005	Cameron et al.
2005/0092247	A1	5/2005	Schmidt	2005/0255257	A1	11/2005	Choi et al.
2005/0092249	A1	5/2005	Kilpela et al.	2005/0255327	A1	11/2005	Chaney et al.
2005/0092733	A1	5/2005	Ito et al.	2005/0258280	A1	11/2005	Goto et al.
2005/0095770	A1	5/2005	Kumagai et al.	2005/0260347	A1	11/2005	Narwankar et al.
2005/0095859	A1	5/2005	Chen et al.	2005/0260837	A1	11/2005	Walther et al.
2005/0098107	A1	5/2005	Du Bois et al.	2005/0260850	A1	11/2005	Loke
2005/0100669	A1	5/2005	Kools et al.	2005/0263072	A1	12/2005	Balasubramanian et al.
2005/0101154	A1	5/2005	Huang	2005/0263075	A1	12/2005	Wang et al.
2005/0101843	A1	5/2005	Quinn et al.	2005/0263932	A1	12/2005	Heugel
2005/0106762	A1	5/2005	Chakrapani et al.	2005/0268856	A1	12/2005	Miller et al.
2005/0106893	A1	5/2005	Wilk	2005/0271812	A1	12/2005	Myo et al.
2005/0107627	A1	5/2005	Dussarrat et al.	2005/0271813	A1	12/2005	Kher et al.
2005/0109461	A1	5/2005	Sun	2005/0274323	A1	12/2005	Seidel et al.
2005/0110069	A1	5/2005	Kil et al.	2005/0277271	A1	12/2005	Beintner
2005/0115946	A1	6/2005	Shim et al.	2005/0282101	A1	12/2005	Adachi
2005/0118804	A1	6/2005	Byun et al.	2005/0282350	A1	12/2005	Chou et al.
2005/0118837	A1	6/2005	Todd	2005/0284573	A1	12/2005	Egley et al.
2005/0120805	A1	6/2005	Lane	2005/0284991	A1	12/2005	Saez
2005/0120962	A1	6/2005	Ushioda et al.	2005/0285097	A1	12/2005	Shang et al.
2005/0121145	A1	6/2005	Du Bois et al.	2005/0287725	A1	12/2005	Kitagawa
2005/0123690	A1	6/2005	Derderian et al.	2005/0287771	A1	12/2005	Seamons et al.
2005/0130427	A1	6/2005	Seok-Jun	2006/0000411	A1	1/2006	Seo
2005/0132957	A1	6/2005	El-Raghy	2006/0009044	A1	1/2006	Igeta et al.
2005/0133161	A1	6/2005	Carpenter et al.	2006/0013674	A1	1/2006	Elliott et al.
2005/0136188	A1	6/2005	Chang	2006/0013946	A1	1/2006	Park et al.
2005/0139160	A1	6/2005	Lei et al.	2006/0014384	A1	1/2006	Lee et al.
2005/0141591	A1	6/2005	Sakano	2006/0014397	A1	1/2006	Seamons et al.
2005/0142361	A1	6/2005	Nakanishi	2006/0016783	A1	1/2006	Wu et al.
2005/0145338	A1	7/2005	Park et al.	2006/0019033	A1	1/2006	Muthukrishnan et al.
2005/0148162	A1	7/2005	Chen et al.	2006/0019502	A1	1/2006	Park et al.
2005/0153571	A1	7/2005	Senzaki	2006/0021572	A1	2/2006	Wolden
2005/0160987	A1	7/2005	Kasai et al.	2006/0021573	A1	2/2006	Monsma et al.
2005/0161434	A1	7/2005	Sugawara et al.	2006/0021703	A1	2/2006	Umotoy et al.
2005/0172895	A1	8/2005	Kijima et al.	2006/0024439	A2	2/2006	Tuominen et al.
2005/0173003	A1	8/2005	Laverdiere et al.	2006/0026314	A1	2/2006	Franchuk et al.
2005/0175789	A1	8/2005	Helms	2006/0040054	A1	2/2006	Pearlstein et al.
2005/0181535	A1	8/2005	Yun et al.	2006/0040508	A1	2/2006	Ji
2005/0181555	A1	8/2005	Haukka et al.	2006/0046518	A1	3/2006	Hill et al.
2005/0183827	A1	8/2005	White et al.	2006/0048710	A1	3/2006	Horiguchi et al.
2005/0186688	A1	8/2005	Basceri	2006/0051520	A1	3/2006	Behle et al.
2005/0187647	A1	8/2005	Wang et al.	2006/0051925	A1	3/2006	Ahn et al.
2005/0191828	A1	9/2005	Al-Bayati et al.	2006/0057799	A1	3/2006	Horiguchi et al.
2005/0193948	A1	9/2005	Oohirabaru et al.	2006/0057828	A1	3/2006	Omura
2005/0199013	A1	9/2005	Vandroux et al.	2006/0060930	A1	3/2006	Metz et al.
2005/0199342	A1	9/2005	Shajii et al.	2006/0062910	A1	3/2006	Meiere
2005/0208217	A1	9/2005	Shinriki et al.	2006/0063346	A1	3/2006	Lee et al.
2005/0208219	A1	9/2005	Basceri	2006/0068104	A1	3/2006	Ishizaka
2005/0208718	A1	9/2005	Lim et al.	2006/0068121	A1	3/2006	Lee et al.
2005/0211167	A1	9/2005	Gunji	2006/0068125	A1	3/2006	Radhakrishnan
2005/0212119	A1	9/2005	Shero	2006/0081558	A1	4/2006	Collins et al.
2005/0214457	A1	9/2005	Schmitt et al.	2006/0087638	A1	4/2006	Hirayanagi
2005/0214458	A1	9/2005	Meiere	2006/0093756	A1	5/2006	Rajagopalan et al.
2005/0208778	A1	10/2005	Li	2006/0094236	A1	5/2006	Elkins et al.
2005/0218462	A1	10/2005	Ahn et al.	2006/0096540	A1	5/2006	Choi
2005/0221021	A1	10/2005	Strang	2006/0099782	A1	5/2006	Ritenour
2005/0221618	A1	10/2005	AmRhein et al.	2006/0105566	A1	5/2006	Waldfried et al.
2005/0223982	A1	10/2005	Park et al.	2006/0107898	A1	5/2006	Blomberg
2005/0223994	A1	10/2005	Blomiley et al.	2006/0108221	A1	5/2006	Goodwin et al.
2005/0227502	A1	10/2005	Schmitt et al.	2006/0108331	A1	5/2006	Nozawa et al.
2005/0229848	A1	10/2005	Shinriki	2006/0110934	A1	5/2006	Fukuchi
2005/0229849	A1	10/2005	Silveti et al.	2006/0113038	A1	6/2006	Gondhalekar et al.
2005/0229972	A1	10/2005	Hoshi et al.	2006/0113675	A1	6/2006	Chang et al.
				2006/0113806	A1	6/2006	Tsuji et al.
				2006/0125099	A1	6/2006	Gordon et al.
				2006/0127067	A1	6/2006	Wintenberger et al.
				2006/0128142	A1	6/2006	Whelan et al.

(56)

References Cited

U.S. PATENT DOCUMENTS

2006/0128168 A1	6/2006	Ahn et al.	2007/0010072 A1	1/2007	Bailey et al.
2006/0130767 A1	6/2006	Herchen	2007/0012402 A1	1/2007	Sneh
2006/0137608 A1	6/2006	Choi et al.	2007/0020160 A1	1/2007	Berkman et al.
2006/0137609 A1	6/2006	Puchacz et al.	2007/0020167 A1	1/2007	Han et al.
2006/0141155 A1	6/2006	Gordon et al.	2007/0020830 A1	1/2007	Speranza
2006/0144820 A1	7/2006	Sawin et al.	2007/0020953 A1	1/2007	Tsai et al.
2006/0147626 A1	7/2006	Blomberg	2007/0022954 A1	2/2007	Iizuka et al.
2006/0148180 A1	7/2006	Ahn et al.	2007/0026148 A1	2/2007	Arai et al.
2006/0151117 A1	7/2006	Kasanami et al.	2007/0026162 A1	2/2007	Wei et al.
2006/0154424 A1	7/2006	Yang et al.	2007/0028842 A1	2/2007	Inagawa et al.
2006/0156981 A1	7/2006	Fondurulia	2007/0031598 A1	2/2007	Okuyama et al.
2006/0163612 A1	7/2006	Kouvetakis et al.	2007/0031599 A1	2/2007	Gschwandtner et al.
2006/0163683 A1	7/2006	Roth et al.	2007/0032045 A1	2/2007	Kasahara et al.
2006/0165892 A1	7/2006	Weidman	2007/0032082 A1	2/2007	Ramaswamy et al.
2006/0166428 A1	7/2006	Kamioka	2007/0034477 A1	2/2007	Inui
2006/0172531 A1	8/2006	Lin et al.	2007/0037343 A1	2/2007	Colombo et al.
2006/0175669 A1	8/2006	Kim et al.	2007/0037412 A1	2/2007	Dip et al.
2006/0177855 A1	8/2006	Utermohlen	2007/0042117 A1	2/2007	Kupurao et al.
2006/0182885 A1	8/2006	Lei et al.	2007/0045244 A1	3/2007	Lee et al.
2006/0185589 A1	8/2006	Zehavi et al.	2007/0049053 A1	3/2007	Mahajani
2006/0188360 A1	8/2006	Bonora et al.	2007/0051299 A1	3/2007	Ong et al.
2006/0191555 A1	8/2006	Yoshida et al.	2007/0051312 A1	3/2007	Sneh
2006/0193979 A1	8/2006	Meiere et al.	2007/0051471 A1	3/2007	Kawaguchi et al.
2006/0196418 A1	9/2006	Lindfors et al.	2007/0054049 A1	3/2007	Lindfors et al.
2006/0196420 A1	9/2006	Ushakov et al.	2007/0054499 A1	3/2007	Jang
2006/0196421 A1	9/2006	Ronsse et al.	2007/0056843 A1	3/2007	Ye et al.
2006/0199357 A1	9/2006	Wan et al.	2007/0056850 A1	3/2007	Ye et al.
2006/0205194 A1	9/2006	Bauer	2007/0059948 A1	3/2007	Metzner et al.
2006/0205223 A1	9/2006	Smayling	2007/0062439 A1	3/2007	Wada et al.
2006/0205231 A1	9/2006	Chou et al.	2007/0062453 A1	3/2007	Ishikawa
2006/0208215 A1	9/2006	Metzner et al.	2007/0062646 A1	3/2007	Ogawa et al.
2006/0211243 A1	9/2006	Ishizaka et al.	2007/0065578 A1	3/2007	McDougall
2006/0211259 A1	9/2006	Maes	2007/0066010 A1	3/2007	Ando
2006/0213437 A1	9/2006	Ishizaka et al.	2007/0066038 A1	3/2007	Sadjadi et al.
2006/0213439 A1	9/2006	Ishizaka	2007/0066079 A1	3/2007	Kolster et al.
2006/0216942 A1	9/2006	Kim et al.	2007/0066084 A1	3/2007	Wajda et al.
2006/0219169 A1	10/2006	Chen et al.	2007/0074665 A1	4/2007	Chacin et al.
2006/0223301 A1	10/2006	Vanhaelemeersch et al.	2007/0077355 A1	4/2007	Chacin et al.
2006/0226117 A1	10/2006	Bertram et al.	2007/0082132 A1	4/2007	Shinriki
2006/0228496 A1	10/2006	Choi	2007/0082500 A1	4/2007	Norman et al.
2006/0228863 A1	10/2006	Zhang et al.	2007/0084405 A1	4/2007	Kim
2006/0228888 A1	10/2006	Lee et al.	2007/0087296 A1	4/2007	Kim et al.
2006/0228898 A1	10/2006	Wajda et al.	2007/0087579 A1	4/2007	Kitayama et al.
2006/0236934 A1	10/2006	Choi et al.	2007/0089670 A1	4/2007	Ikedo
2006/0240187 A1	10/2006	Weidman	2007/0095283 A1	5/2007	Galewski
2006/0240574 A1	10/2006	Yoshie	2007/0095286 A1	5/2007	Baek et al.
2006/0240662 A1	10/2006	Conley et al.	2007/0096194 A1	5/2007	Streck et al.
2006/0247404 A1	11/2006	Todd	2007/0098527 A1	5/2007	Hall et al.
2006/0249253 A1	11/2006	Dando	2007/0107845 A1	5/2007	Ishizawa et al.
2006/0251827 A1	11/2006	Nowak	2007/0111470 A1	5/2007	Smythe
2006/0252228 A1	11/2006	Jeng	2007/0111545 A1	5/2007	Lee et al.
2006/0252351 A1	11/2006	Kundracik	2007/0113788 A1	5/2007	Nozawa et al.
2006/0257563 A1	11/2006	Doh et al.	2007/0116872 A1	5/2007	Li et al.
2006/0257584 A1	11/2006	Derderian et al.	2007/0116873 A1	5/2007	Li et al.
2006/0258078 A1	11/2006	Lee et al.	2007/0116887 A1	5/2007	Faguet
2006/0258173 A1	11/2006	Xiao et al.	2007/0116888 A1	5/2007	Faguet
2006/0260545 A1	11/2006	Ramaswamy et al.	2007/0119370 A1	5/2007	Ma et al.
2006/0263522 A1	11/2006	Byun	2007/0120275 A1	5/2007	Liu
2006/0264060 A1	11/2006	Ramaswamy et al.	2007/0123037 A1	5/2007	Lee et al.
2006/0264066 A1	11/2006	Bartholomew	2007/0123189 A1	5/2007	Saito et al.
2006/0266289 A1	11/2006	Vergheze et al.	2007/0125762 A1	6/2007	Cui et al.
2006/0269690 A1	11/2006	Watanabe et al.	2007/0128538 A1	6/2007	Fairbairn et al.
2006/0269692 A1	11/2006	Balseanu	2007/0128858 A1	6/2007	Haukka et al.
2006/0275710 A1	12/2006	Yamazaki et al.	2007/0128876 A1	6/2007	Fukiage
2006/0275933 A1	12/2006	Du Bois et al.	2007/0128888 A1	6/2007	Goto et al.
2006/0278524 A1	12/2006	Stowell	2007/0129621 A1	6/2007	Kellogg et al.
2006/0283629 A1	12/2006	Kikuchi et al.	2007/0131168 A1	6/2007	Gomi et al.
2006/0286774 A1	12/2006	Singh et al.	2007/0134919 A1	6/2007	Gunji et al.
2006/0286775 A1	12/2006	Singh et al.	2007/0134942 A1	6/2007	Ahn et al.
2006/0286817 A1	12/2006	Kato et al.	2007/0137794 A1	6/2007	Qiu et al.
2006/0286818 A1	12/2006	Wang et al.	2007/0146621 A1	6/2007	Yeom
2006/0286819 A1	12/2006	Seutter	2007/0148347 A1	6/2007	Hatanpaa et al.
2006/0291982 A1	12/2006	Tanaka	2007/0148350 A1	6/2007	Rahtu
2006/0292310 A1	12/2006	Le et al.	2007/0148990 A1	6/2007	Deboer et al.
2007/0006806 A1	1/2007	Imai	2007/0153625 A1	6/2007	Lundgren et al.
			2007/0155138 A1	7/2007	Tomasini et al.
			2007/0157466 A1	7/2007	Kida et al.
			2007/0157683 A1	7/2007	Li
			2007/0158026 A1	7/2007	Amikura

(56)

References Cited

U.S. PATENT DOCUMENTS

- 2007/0163440 A1 7/2007 Kim et al.
 2007/0163625 A1 7/2007 Lee
 2007/0163996 A1 7/2007 Horiguchi
 2007/0166457 A1 7/2007 Yamoto et al.
 2007/0166966 A1 7/2007 Todd et al.
 2007/0166999 A1 7/2007 Vaarstra
 2007/0170372 A1 7/2007 Horsky
 2007/0173071 A1 7/2007 Afzali-Ardakani et al.
 2007/0175393 A1 8/2007 Nishimura et al.
 2007/0175397 A1 8/2007 Tomiyasu et al.
 2007/0178235 A1 8/2007 Yamada et al.
 2007/0181066 A1 8/2007 Cadwell et al.
 2007/0184179 A1 8/2007 Waghray et al.
 2007/0186849 A1 8/2007 Furuya
 2007/0186952 A1 8/2007 Honda et al.
 2007/0187362 A1 8/2007 Nakagawa et al.
 2007/0187363 A1 8/2007 Oka et al.
 2007/0190362 A1 8/2007 Weidman
 2007/0190782 A1 8/2007 Park
 2007/0202678 A1 8/2007 Plombon et al.
 2007/0207275 A1 9/2007 Nowak et al.
 2007/0209588 A1 9/2007 Li et al.
 2007/0209590 A1 9/2007 Li
 2007/0210890 A1 9/2007 Hsu et al.
 2007/0212484 A1 9/2007 Li
 2007/0215048 A1 9/2007 Suzuki et al.
 2007/0218200 A1 9/2007 Suzuki et al.
 2007/0218705 A1 9/2007 Matsuki et al.
 2007/0224777 A1 9/2007 Hamelin
 2007/0224833 A1 9/2007 Morisada et al.
 2007/0231488 A1 10/2007 Von Kaenel
 2007/0232031 A1 10/2007 Singh et al.
 2007/0232071 A1 10/2007 Balseanu et al.
 2007/0232501 A1 10/2007 Tonomura
 2007/0234955 A1 10/2007 Suzuki et al.
 2007/0237697 A1 10/2007 Clark
 2007/0237698 A1 10/2007 Clark
 2007/0237699 A1 10/2007 Clark
 2007/0238305 A1 10/2007 Delgadino et al.
 2007/0241688 A1 10/2007 DeVancentis et al.
 2007/0243317 A1 10/2007 Du Bois et al.
 2007/0247075 A1 10/2007 Kim et al.
 2007/0248767 A1 10/2007 Okura
 2007/0249131 A1 10/2007 Allen et al.
 2007/0251444 A1 11/2007 Gros-Jean et al.
 2007/0251456 A1 11/2007 Herchen et al.
 2007/0252233 A1 11/2007 Yamazaki et al.
 2007/0252244 A1 11/2007 Srividya et al.
 2007/0252532 A1 11/2007 DeVancentis et al.
 2007/0254414 A1 11/2007 Miyanami
 2007/0258506 A1 11/2007 Schwagerman et al.
 2007/0258855 A1 11/2007 Turcot et al.
 2007/0259778 A1 11/2007 Spencer et al.
 2007/0261868 A1 11/2007 Gross
 2007/0264807 A1 11/2007 Leone et al.
 2007/0266932 A1 11/2007 Hiramatsu
 2007/0266945 A1 11/2007 Shuto et al.
 2007/0269983 A1 11/2007 Sneh
 2007/0275166 A1 11/2007 Thridandam et al.
 2007/0277735 A1 12/2007 Mokhesi et al.
 2007/0281082 A1 12/2007 Mokhesi et al.
 2007/0281105 A1 12/2007 Mokhesi et al.
 2007/0281496 A1 12/2007 Ingle et al.
 2007/0286957 A1 12/2007 Suzuki et al.
 2007/0292974 A1 12/2007 Mizuno et al.
 2007/0295602 A1 12/2007 Tiller et al.
 2007/0298362 A1 12/2007 Rocha-Alvarez et al.
 2008/0003425 A1 1/2008 Spencer et al.
 2008/0003824 A1 1/2008 Padhi et al.
 2008/0003838 A1 1/2008 Haukka et al.
 2008/0006208 A1 1/2008 Ueno et al.
 2008/0018004 A1 1/2008 Steidl
 2008/0020591 A1 1/2008 Balseanu et al.
 2008/0020593 A1 1/2008 Wang et al.
 2008/0023436 A1 1/2008 Gros-Jean et al.
 2008/0026162 A1 1/2008 Dickey et al.
 2008/0026574 A1 1/2008 Brcka
 2008/0026597 A1 1/2008 Munro et al.
 2008/0029790 A1 2/2008 Ahn et al.
 2008/0031708 A1 2/2008 Bonora et al.
 2008/0035055 A1 2/2008 Dip et al.
 2008/0036354 A1 2/2008 Letz et al.
 2008/0038485 A1 2/2008 Fukazawa et al.
 2008/0038934 A1 2/2008 Vrtis et al.
 2008/0042165 A1 2/2008 Sugizaki
 2008/0042192 A1 2/2008 Park et al.
 2008/0043803 A1 2/2008 Bando
 2008/0044938 A1 2/2008 England et al.
 2008/0050536 A1 2/2008 Aing et al.
 2008/0050538 A1 2/2008 Hirata
 2008/0054332 A1 3/2008 Kim et al.
 2008/0054813 A1 3/2008 Espiau et al.
 2008/0056860 A1 3/2008 Natume
 2008/0057659 A1 3/2008 Forbes et al.
 2008/0061667 A1 3/2008 Gaertner et al.
 2008/0063798 A1 3/2008 Kher et al.
 2008/0066778 A1 3/2008 Matsushita et al.
 2008/0067146 A1 3/2008 Onishi et al.
 2008/0069955 A1 3/2008 Hong et al.
 2008/0072821 A1 3/2008 Dalton et al.
 2008/0075562 A1 3/2008 Maria et al.
 2008/0075881 A1 3/2008 Won et al.
 2008/0076070 A1 3/2008 Koh et al.
 2008/0076266 A1 3/2008 Fukazawa et al.
 2008/0076281 A1 3/2008 Ciancanelli et al.
 2008/0081104 A1 4/2008 Hasebe et al.
 2008/0081113 A1 4/2008 Clark
 2008/0081121 A1 4/2008 Morita et al.
 2008/0085226 A1 4/2008 Fondurulia et al.
 2008/0085610 A1 4/2008 Wang et al.
 2008/0087218 A1 4/2008 Shimada et al.
 2008/0092815 A1 4/2008 Chen et al.
 2008/0099147 A1 5/2008 Myo et al.
 2008/0102203 A1 5/2008 Wu
 2008/0102205 A1 5/2008 Barry et al.
 2008/0102208 A1 5/2008 Wu et al.
 2008/0102603 A1 5/2008 Kobayashi et al.
 2008/0105276 A1 5/2008 Yeh et al.
 2008/0113094 A1 5/2008 Casper
 2008/0113096 A1 5/2008 Mahajani
 2008/0113097 A1 5/2008 Mahajani et al.
 2008/0118334 A1 5/2008 Bonora
 2008/0121177 A1 5/2008 Bang et al.
 2008/0121626 A1 5/2008 Thomas et al.
 2008/0124197 A1 5/2008 van der Meulen et al.
 2008/0124908 A1 5/2008 Forbes et al.
 2008/0124945 A1 5/2008 Miya et al.
 2008/0124946 A1 5/2008 Xiao et al.
 2008/0128726 A1 6/2008 Sakata et al.
 2008/0129209 A1 6/2008 Deakins et al.
 2008/0132046 A1 6/2008 Walther
 2008/0133154 A1 6/2008 Krauss et al.
 2008/0134887 A1 6/2008 Sherer
 2008/0142483 A1 6/2008 Hua
 2008/0146033 A1 6/2008 Park
 2008/0149031 A1 6/2008 Chu et al.
 2008/0149593 A1 6/2008 Bai et al.
 2008/0152463 A1 6/2008 Chidambaram et al.
 2008/0153308 A1 6/2008 Ogawa et al.
 2008/0153311 A1 6/2008 Padhi et al.
 2008/0157157 A1 7/2008 Tonomura
 2008/0157365 A1 7/2008 Ott et al.
 2008/0173237 A1 7/2008 Collins
 2008/0173238 A1 7/2008 Nakashima et al.
 2008/0173240 A1 7/2008 Furukawahara
 2008/0173326 A1 7/2008 Gu et al.
 2008/0176335 A1 7/2008 Alberti et al.
 2008/0176375 A1 7/2008 Erben et al.
 2008/0176412 A1 7/2008 Komeda
 2008/0178805 A1 7/2008 Paterson et al.
 2008/0179104 A1 7/2008 Zhang
 2008/0179291 A1 7/2008 Collins et al.
 2008/0179715 A1 7/2008 Coppa
 2008/0182075 A1 7/2008 Chopra

(56)

References Cited

U.S. PATENT DOCUMENTS

2008/0182390 A1	7/2008	Lemmi et al.	2009/0033907 A1	2/2009	Watson
2008/0182411 A1	7/2008	Elers	2009/0035584 A1	2/2009	Tran et al.
2008/0191193 A1	8/2008	Li et al.	2009/0035927 A1	2/2009	Olsen et al.
2008/0193643 A1	8/2008	Dip	2009/0035947 A1	2/2009	Horii
2008/0194105 A1	8/2008	Dominguez et al.	2009/0036292 A1	2/2009	Sun et al.
2008/0199977 A1	8/2008	Weigel et al.	2009/0041952 A1	2/2009	Yoon et al.
2008/0202416 A1	8/2008	Provencher	2009/0041984 A1	2/2009	Mayers et al.
2008/0202689 A1	8/2008	Kim	2009/0042344 A1	2/2009	Ye et al.
2008/0203487 A1	8/2008	Hohage et al.	2009/0042408 A1	2/2009	Maeda
2008/0205483 A1	8/2008	Rempe et al.	2009/0045829 A1	2/2009	Awazu
2008/0210278 A1	9/2008	Orii et al.	2009/0047426 A1	2/2009	Park et al.
2008/0211423 A1	9/2008	Shinmen et al.	2009/0047433 A1	2/2009	Kim et al.
2008/0211526 A1	9/2008	Shinma	2009/0050621 A1	2/2009	Awazu
2008/0213696 A1	9/2008	Meeus et al.	2009/0052498 A1	2/2009	Halpin et al.
2008/0214003 A1	9/2008	Xia et al.	2009/0053023 A1	2/2009	Wakabayashi
2008/0216077 A1	9/2008	Emani et al.	2009/0053900 A1	2/2009	Nozawa et al.
2008/0216742 A1	9/2008	Takebayashi	2009/0053906 A1	2/2009	Miya et al.
2008/0216958 A1	9/2008	Goto et al.	2009/0056112 A1	3/2009	Kobayashi
2008/0220619 A1	9/2008	Matsushita et al.	2009/0056629 A1	3/2009	Katz et al.
2008/0223130 A1	9/2008	Snell et al.	2009/0057269 A1	3/2009	Katz et al.
2008/0224240 A1	9/2008	Ahn et al.	2009/0061083 A1	3/2009	Chiang et al.
2008/0228306 A1	9/2008	Yetter et al.	2009/0061644 A1	3/2009	Chiang et al.
2008/0230371 A1	9/2008	McHugh	2009/0061647 A1	3/2009	Mallick et al.
2008/0233288 A1	9/2008	Clark	2009/0075491 A1	3/2009	Liu et al.
2008/0237572 A1	10/2008	Chui et al.	2009/0081879 A1	3/2009	Sukekawa et al.
2008/0241052 A1	10/2008	Hooper et al.	2009/0084317 A1	4/2009	Wu
2008/0241384 A1	10/2008	Jeong	2009/0085156 A1	4/2009	Dewey et al.
2008/0241387 A1	10/2008	Keto	2009/0087585 A1	4/2009	Lee et al.
2008/0242116 A1	10/2008	Clark	2009/0090382 A1	4/2009	Morisada
2008/0248310 A1	10/2008	Kim et al.	2009/0093080 A1	4/2009	Choi et al.
2008/0248597 A1	10/2008	Qin et al.	2009/0093094 A1	4/2009	Ye et al.
2008/0257102 A1	10/2008	Packer	2009/0095221 A1	4/2009	Tam et al.
2008/0257494 A1	10/2008	Hayashi et al.	2009/0104351 A1	4/2009	Kakegawa
2008/0260345 A1	10/2008	Mertesdorf et al.	2009/0104594 A1	4/2009	Webb
2008/0260963 A1	10/2008	Yoon et al.	2009/0104789 A1	4/2009	Mallick et al.
2008/0261405 A1	10/2008	Yang et al.	2009/0107404 A1	4/2009	Ogliari et al.
2008/0261413 A1	10/2008	Mahajani	2009/0108308 A1	4/2009	Yang et al.
2008/0264337 A1	10/2008	Sano et al.	2009/0112458 A1	4/2009	Nakai
2008/0267598 A1	10/2008	Nakamura	2009/0115064 A1	5/2009	Sandhu et al.
2008/0268171 A1	10/2008	Ma et al.	2009/0116936 A1	5/2009	Marubayashi et al.
2008/0268635 A1	10/2008	Yu et al.	2009/0117717 A1	5/2009	Tomasini et al.
2008/0272424 A1	11/2008	Kim et al.	2009/0117746 A1	5/2009	Masuda
2008/0274369 A1	11/2008	Lee et al.	2009/0120580 A1	5/2009	Kagoshima et al.
2008/0277647 A1	11/2008	Kouvetakis et al.	2009/0122293 A1	5/2009	Shibazaki
2008/0277715 A1	11/2008	Ohmi et al.	2009/0122458 A1	5/2009	Lischer et al.
2008/0282970 A1	11/2008	Heys et al.	2009/0124131 A1	5/2009	Breunsbach et al.
2008/0283962 A1	11/2008	Dyer	2009/0130331 A1	5/2009	Asai
2008/0286463 A1	11/2008	Tiner et al.	2009/0130859 A1	5/2009	Itatani et al.
2008/0289574 A1	11/2008	Jacobs et al.	2009/0136665 A1	5/2009	Choi et al.
2008/0291964 A1	11/2008	Shrimpling	2009/0136668 A1	5/2009	Gregg et al.
2008/0295872 A1	12/2008	Riker et al.	2009/0136683 A1	5/2009	Fukasawa et al.
2008/0298945 A1	12/2008	Cox	2009/0137055 A1	5/2009	Bognar
2008/0299326 A1	12/2008	Fukazawa	2009/0139657 A1	6/2009	Lee et al.
2008/0299758 A1	12/2008	Harada et al.	2009/0142905 A1	6/2009	Yamazaki
2008/0302303 A1	12/2008	Choi et al.	2009/0142935 A1	6/2009	Fukazawa et al.
2008/0303744 A1	12/2008	Hirayama et al.	2009/0146322 A1	6/2009	Weling et al.
2008/0305014 A1	12/2008	Honda	2009/0147819 A1	6/2009	Goodman et al.
2008/0305246 A1	12/2008	Choi et al.	2009/0155488 A1	6/2009	Nakano et al.
2008/0305443 A1	12/2008	Nakamura	2009/0156015 A1	6/2009	Park et al.
2008/0314319 A1	12/2008	Hamano et al.	2009/0156017 A1	6/2009	Fukazawa et al.
2008/0314892 A1	12/2008	Graham	2009/0159000 A1	6/2009	Aggarwal et al.
2008/0315292 A1	12/2008	Ji et al.	2009/0159002 A1	6/2009	Bera et al.
2008/0317972 A1	12/2008	Hendriks	2009/0159424 A1	6/2009	Liu et al.
2009/0000550 A1	1/2009	Tran et al.	2009/0162647 A1	6/2009	Sun et al.
2009/0000551 A1	1/2009	Choi et al.	2009/0162996 A1	6/2009	Ramaswamy et al.
2009/0000769 A1	1/2009	Lin et al.	2009/0163038 A1	6/2009	Miyoshi
2009/0004875 A1	1/2009	Shen et al.	2009/0165715 A1	7/2009	Oh
2009/0011145 A1	1/2009	Yun	2009/0165721 A1	7/2009	Pitney et al.
2009/0011608 A1	1/2009	Nabatame	2009/0165722 A1	7/2009	Ha
2009/0017631 A1	1/2009	Bencher	2009/0166616 A1	7/2009	Uchiyama
2009/0020072 A1	1/2009	Mizunaga et al.	2009/0179365 A1	7/2009	Lerner et al.
2009/0023229 A1	1/2009	Matsushita	2009/0186571 A1	7/2009	Haro
2009/0029503 A1	1/2009	Arai	2009/0194233 A1	8/2009	Tamura et al.
2009/0029528 A1	1/2009	Sanchez et al.	2009/0197015 A1	8/2009	Kudela et al.
2009/0029564 A1	1/2009	Yamashita et al.	2009/0197411 A1	8/2009	Dussarrat et al.
			2009/0200494 A1	8/2009	Hatem
			2009/0200547 A1	8/2009	Griffin et al.
			2009/0204403 A1	8/2009	Hollander et al.
			2009/0206056 A1	8/2009	Xu

- (56) **References Cited**
- U.S. PATENT DOCUMENTS
- 2009/0209081 A1 8/2009 Matero
- 2009/0211523 A1 8/2009 Kuppurao et al.
- 2009/0211525 A1 8/2009 Sarigiannis et al.
- 2009/0214825 A1 8/2009 Sun et al.
- 2009/0217871 A1 9/2009 Kim et al.
- 2009/0223441 A1 9/2009 Arena et al.
- 2009/0227094 A1 9/2009 Bateman
- 2009/0230211 A1 9/2009 Kobayashi et al.
- 2009/0232985 A1 9/2009 Dussarrat et al.
- 2009/0236014 A1 9/2009 Wilson
- 2009/0236276 A1 9/2009 Kurth et al.
- 2009/0239386 A1 9/2009 Suzaki et al.
- 2009/0242130 A1 10/2009 Tian et al.
- 2009/0242957 A1 10/2009 Ma et al.
- 2009/0246374 A1 10/2009 Vukovic
- 2009/0246399 A1 10/2009 Goundar
- 2009/0246971 A1 10/2009 Reid et al.
- 2009/0250004 A1 10/2009 Yamada et al.
- 2009/0250955 A1 10/2009 Aoki
- 2009/0255901 A1 10/2009 Okita
- 2009/0256127 A1 10/2009 Feist et al.
- 2009/0261331 A1 10/2009 Yang et al.
- 2009/0267135 A1 10/2009 Tanaka et al.
- 2009/0267225 A1 10/2009 Eguchi
- 2009/0269506 A1 10/2009 Okura et al.
- 2009/0269507 A1 10/2009 Yu et al.
- 2009/0269941 A1 10/2009 Raisanen
- 2009/0275205 A1 11/2009 Kiehlbauch et al.
- 2009/0275210 A1 11/2009 Shanker et al.
- 2009/0277510 A1 11/2009 Shikata
- 2009/0277874 A1 11/2009 Rui et al.
- 2009/0280248 A1 11/2009 Goodman et al.
- 2009/0283041 A1 11/2009 Tomiyasu et al.
- 2009/0283217 A1 11/2009 Lubomirsky et al.
- 2009/0284156 A1 11/2009 Banna et al.
- 2009/0286400 A1 11/2009 Heo et al.
- 2009/0286402 A1 11/2009 Xia et al.
- 2009/0289300 A1 11/2009 Sasaki et al.
- 2009/0297710 A1 12/2009 Lindfors
- 2009/0298257 A1 12/2009 Lee et al.
- 2009/0302002 A1 12/2009 Collins et al.
- 2009/0302434 A1 12/2009 Pallem et al.
- 2009/0304558 A1 12/2009 Patton
- 2009/0308315 A1 12/2009 de Ridder
- 2009/0308425 A1 12/2009 Yednak
- 2009/0311857 A1 12/2009 Todd et al.
- 2009/0315093 A1 12/2009 Li et al.
- 2009/0317214 A1 12/2009 Hsiao et al.
- 2009/0320754 A1 12/2009 Oya
- 2009/0324971 A1 12/2009 De Vries et al.
- 2009/0324989 A1 12/2009 Witz et al.
- 2009/0325391 A1 12/2009 De Vusser et al.
- 2009/0325469 A1 12/2009 Koo et al.
- 2010/0000608 A1 1/2010 Goto et al.
- 2010/0001409 A1 1/2010 Humbert et al.
- 2010/0003406 A1 1/2010 Lam et al.
- 2010/0006031 A1 1/2010 Choi et al.
- 2010/0006923 A1 1/2010 Fujitsuka
- 2010/0012036 A1 1/2010 Silva et al.
- 2010/0014479 A1 1/2010 Kim
- 2010/0015813 A1 1/2010 McGinnis et al.
- 2010/0018460 A1 1/2010 Singh et al.
- 2010/0024727 A1 2/2010 Kim et al.
- 2010/0024872 A1 2/2010 Kishimoto
- 2010/0025766 A1 2/2010 Nuttinck et al.
- 2010/0025796 A1 2/2010 Dabiran
- 2010/0032587 A1 2/2010 Hosch et al.
- 2010/0032842 A1 2/2010 Herdt et al.
- 2010/0034719 A1 2/2010 Dussarrat et al.
- 2010/0040441 A1 2/2010 Obikane
- 2010/0041179 A1 2/2010 Lee
- 2010/0041243 A1 2/2010 Cheng et al.
- 2010/0050943 A1 3/2010 Kato et al.
- 2010/0051584 A1 3/2010 Okita et al.
- 2010/0051597 A1 3/2010 Morita et al.
- 2010/0055312 A1 3/2010 Kato et al.
- 2010/0055316 A1 3/2010 Honma
- 2010/0055318 A1 3/2010 Volf et al.
- 2010/0055442 A1 3/2010 Kellock
- 2010/0055898 A1 3/2010 Chang et al.
- 2010/0058984 A1 3/2010 Marubayashi
- 2010/0065758 A1 3/2010 Liu et al.
- 2010/0068009 A1 3/2010 Kimura
- 2010/0068383 A1 3/2010 Kato et al.
- 2010/0068414 A1 3/2010 Takahashi et al.
- 2010/0068891 A1 3/2010 Hatanaka et al.
- 2010/0075037 A1 3/2010 Marsh et al.
- 2010/0075507 A1 3/2010 Chang et al.
- 2010/0081094 A1 4/2010 Hasebe et al.
- 2010/0086703 A1 4/2010 Mangum et al.
- 2010/0089320 A1 4/2010 Kim
- 2010/0089870 A1 4/2010 Hiroshima et al.
- 2010/0090149 A1 4/2010 Thompson et al.
- 2010/0092679 A1 4/2010 Lee et al.
- 2010/0092696 A1 4/2010 Shinriki
- 2010/0093187 A1 4/2010 Lee et al.
- 2010/0098862 A1 4/2010 Xu et al.
- 2010/0101728 A1 4/2010 Iwasaki
- 2010/0102417 A1 4/2010 Ganguli et al.
- 2010/0105936 A1 4/2010 Tada et al.
- 2010/0111648 A1 5/2010 Tamura et al.
- 2010/0112496 A1 5/2010 Nakajima et al.
- 2010/0116207 A1 5/2010 Givens
- 2010/0116209 A1 5/2010 Kato
- 2010/0119439 A1 5/2010 Shindou
- 2010/0119727 A1 5/2010 Takagi
- 2010/0120261 A1 5/2010 Kim et al.
- 2010/0124610 A1 5/2010 Aikawa et al.
- 2010/0124618 A1 5/2010 Kobayashi et al.
- 2010/0124621 A1 5/2010 Kobayashi et al.
- 2010/0126415 A1 5/2010 Ishino et al.
- 2010/0126539 A1 5/2010 Lee et al.
- 2010/0126605 A1 5/2010 Stones
- 2010/0129548 A1 5/2010 Sneh
- 2010/0129990 A1 5/2010 Nishizawa et al.
- 2010/0130015 A1 5/2010 Nakajima et al.
- 2010/0130017 A1 5/2010 Luo et al.
- 2010/0130105 A1 5/2010 Lee
- 2010/0134023 A1 6/2010 Mills
- 2010/0136216 A1 6/2010 Tsuei et al.
- 2010/0140221 A1 6/2010 Kikuchi et al.
- 2010/0140684 A1 6/2010 Ozawa
- 2010/0143609 A1 6/2010 Fukazawa et al.
- 2010/0144162 A1 6/2010 Lee et al.
- 2010/0144968 A1 6/2010 Lee et al.
- 2010/0145547 A1 6/2010 Darabnia et al.
- 2010/0151206 A1 6/2010 Wu et al.
- 2010/0159638 A1 6/2010 Jeong
- 2010/0159707 A1 6/2010 Huang et al.
- 2010/0162752 A1 7/2010 Tabata et al.
- 2010/0162956 A1 7/2010 Murakami et al.
- 2010/0163524 A1 7/2010 Arai
- 2010/0163937 A1 7/2010 Clendenning
- 2010/0166630 A1 7/2010 Gu et al.
- 2010/0168404 A1 7/2010 Girolami et al.
- 2010/0170441 A1 7/2010 Won et al.
- 2010/0170868 A1 7/2010 Lin et al.
- 2010/0173432 A1 7/2010 White et al.
- 2010/0178137 A1 7/2010 Chintalapati et al.
- 2010/0178423 A1 7/2010 Shimizu et al.
- 2010/0180819 A1 7/2010 Hatanaka et al.
- 2010/0183825 A1 7/2010 Becker et al.
- 2010/0184302 A1 7/2010 Lee et al.
- 2010/0186669 A1 7/2010 Shin et al.
- 2010/0193501 A1 8/2010 Zucker et al.
- 2010/0195392 A1 8/2010 Freeman
- 2010/0202860 A1 8/2010 Reed
- 2010/0209598 A1 8/2010 Xu et al.
- 2010/0219757 A1 9/2010 Benzerrouk et al.
- 2010/0221452 A1 9/2010 Kang
- 2010/0224130 A1 9/2010 Smith et al.
- 2010/0229795 A1 9/2010 Tanabe
- 2010/0229965 A1 9/2010 Kashima et al.
- 2010/0230051 A1 9/2010 Iizuka

(56)

References Cited

U.S. PATENT DOCUMENTS

2013/0052836	A1	2/2013	Hirose et al.	2013/0256962	A1	10/2013	Ranish
2013/0059078	A1	3/2013	Gatineau et al.	2013/0264659	A1	10/2013	Jung
2013/0061755	A1	3/2013	Frederick	2013/0267045	A1	10/2013	Lee et al.
2013/0062753	A1	3/2013	Nguyen et al.	2013/0269612	A1	10/2013	Cheng et al.
2013/0064973	A1	3/2013	Chen et al.	2013/0270676	A1	10/2013	Lindert et al.
2013/0065189	A1	3/2013	Yoshii et al.	2013/0276978	A1	10/2013	Bluck et al.
2013/0068727	A1	3/2013	Okita	2013/0280891	A1	10/2013	Kim et al.
2013/0068970	A1	3/2013	Matsushita	2013/0285155	A1	10/2013	Glass
2013/0069052	A1	3/2013	Sandhu	2013/0287526	A1	10/2013	Bluck et al.
2013/0070456	A1	3/2013	Jang et al.	2013/0288427	A1	10/2013	Hung et al.
2013/0078376	A1	3/2013	Higashino et al.	2013/0288471	A1	10/2013	Chi
2013/0078392	A1	3/2013	Xiao et al.	2013/0288480	A1	10/2013	Sanchez et al.
2013/0081702	A1	4/2013	Mohammed et al.	2013/0288485	A1	10/2013	Liang et al.
2013/0082274	A1	4/2013	Yang	2013/0292047	A1	11/2013	Tian et al.
2013/0084156	A1	4/2013	Shimamoto	2013/0292676	A1	11/2013	Milligan et al.
2013/0084408	A1	4/2013	Nakao et al.	2013/0292807	A1	11/2013	Raisanen et al.
2013/0084711	A1	4/2013	Liang et al.	2013/0295779	A1	11/2013	Chandra et al.
2013/0084714	A1	4/2013	Oka et al.	2013/0299944	A1	11/2013	Lai et al.
2013/0089716	A1	4/2013	Krishnamurthy et al.	2013/0302520	A1	11/2013	Wang et al.
2013/0093048	A1	4/2013	Chang et al.	2013/0302999	A1	11/2013	Won et al.
2013/0093321	A1	4/2013	Yoshikawa et al.	2013/0303803	A1	11/2013	Doerr et al.
2013/0095664	A1	4/2013	Matero et al.	2013/0309876	A1	11/2013	Ogawa
2013/0095973	A1	4/2013	Kroneberger et al.	2013/0312663	A1	11/2013	Khosla et al.
2013/0104988	A1	5/2013	Yednak et al.	2013/0313656	A1	11/2013	Tong
2013/0104992	A1	5/2013	Yednak et al.	2013/0319290	A1	12/2013	Xiao et al.
2013/0107415	A1	5/2013	Banna et al.	2013/0320429	A1	12/2013	Thomas
2013/0112251	A1	5/2013	Hang et al.	2013/0323435	A1	12/2013	Xiao et al.
2013/0113085	A1	5/2013	Michaelson et al.	2013/0323859	A1	12/2013	Chen et al.
2013/0115383	A1	5/2013	Lu et al.	2013/0323935	A1	12/2013	Suzuki et al.
2013/0115763	A1	5/2013	Takamura et al.	2013/0330165	A1	12/2013	Wimplinger
2013/0115768	A1	5/2013	Pore et al.	2013/0330911	A1	12/2013	Huang et al.
2013/0118895	A1	5/2013	Roozeboom et al.	2013/0330933	A1	12/2013	Fukazawa et al.
2013/0119018	A1	5/2013	Kanarik et al.	2013/0333619	A1	12/2013	Omari
2013/0122712	A1	5/2013	Kim et al.	2013/0337583	A1	12/2013	Kobayashi et al.
2013/0122722	A1	5/2013	Cissell et al.	2013/0337639	A1	12/2013	Ivanstov et al.
2013/0126515	A1	5/2013	Shero et al.	2013/0337653	A1	12/2013	Kovalgin et al.
2013/0129577	A1	5/2013	Halpin et al.	2013/0340619	A1	12/2013	Tammera
2013/0134148	A1	5/2013	Tachikawa	2013/0344248	A1	12/2013	Clark
2013/0137279	A1	5/2013	Yamamoto et al.	2014/0000843	A1	1/2014	Dunn et al.
2013/0143401	A1	6/2013	Yu et al.	2014/0001520	A1	1/2014	Glass
2013/0152933	A1	6/2013	Lischer et al.	2014/0004274	A1	1/2014	Thompson
2013/0157409	A1	6/2013	Vaidya	2014/0007808	A1	1/2014	Okabe et al.
2013/0157521	A1	6/2013	Aldrich et al.	2014/0014642	A1	1/2014	Elliot et al.
2013/0160709	A1	6/2013	White et al.	2014/0014644	A1	1/2014	Akiba et al.
2013/0161629	A1	6/2013	Han et al.	2014/0015108	A1	1/2014	Kim et al.
2013/0168353	A1	7/2013	Okita et al.	2014/0015186	A1	1/2014	Wessel et al.
2013/0168354	A1	7/2013	Kanarik	2014/0017408	A1	1/2014	Gandikota et al.
2013/0171818	A1	7/2013	Kim et al.	2014/0017414	A1	1/2014	Fukazawa et al.
2013/0175596	A1	7/2013	Cheng et al.	2014/0017908	A1	1/2014	Beynet et al.
2013/0180448	A1	7/2013	Sakaue et al.	2014/0020619	A1	1/2014	Vincent et al.
2013/0183814	A1	7/2013	Huang et al.	2014/0020764	A1	1/2014	Woelk et al.
2013/0186340	A1	7/2013	Omori et al.	2014/0020839	A1	1/2014	Kenney et al.
2013/0189635	A1	7/2013	Lim et al.	2014/0023794	A1	1/2014	Mahajani et al.
2013/0189854	A1	7/2013	Hausmann et al.	2014/0027884	A1	1/2014	Tang et al.
2013/0196502	A1	8/2013	Haukka et al.	2014/0033978	A1	2/2014	Adachi et al.
2013/0196507	A1	8/2013	Ma et al.	2014/0034240	A1	2/2014	Kim et al.
2013/0200518	A1	8/2013	Ahmed et al.	2014/0034632	A1	2/2014	Pan et al.
2013/0202387	A1	8/2013	Hiroki	2014/0036274	A1	2/2014	Marquardt et al.
2013/0203266	A1	8/2013	Hintze	2014/0045324	A1	2/2014	Brabant et al.
2013/0203267	A1	8/2013	Pomarede et al.	2014/0045342	A1	2/2014	Mallick et al.
2013/0209940	A1	8/2013	Sakamoto et al.	2014/0047705	A1	2/2014	Singh
2013/0210241	A1	8/2013	Lavoie et al.	2014/0048765	A1	2/2014	Ma et al.
2013/0214232	A1	8/2013	Tendulkar et al.	2014/0056679	A1	2/2014	Yamabe et al.
2013/0217239	A1	8/2013	Mallick et al.	2014/0056770	A1	2/2014	Bedard et al.
2013/0217240	A1	8/2013	Mallick et al.	2014/0057454	A1	2/2014	Subramonium
2013/0217241	A1	8/2013	Underwood et al.	2014/0058179	A1	2/2014	Stevens et al.
2013/0217243	A1	8/2013	Underwood et al.	2014/0060147	A1	3/2014	Sarin et al.
2013/0219853	A1	8/2013	Little et al.	2014/0060572	A1	3/2014	Yasumuro et al.
2013/0224964	A1	8/2013	Fukazawa	2014/0061770	A1	3/2014	Lee
2013/0228225	A1	9/2013	Leeser	2014/0062304	A1	3/2014	Nakano et al.
2013/0230814	A1	9/2013	Dunn et al.	2014/0065841	A1	3/2014	Matero
2013/0234203	A1	9/2013	Tsai et al.	2014/0067110	A1	3/2014	Lawson et al.
2013/0242287	A1	9/2013	Schlezingar	2014/0072710	A1	3/2014	Valle
2013/0256265	A1	10/2013	Darling et al.	2014/0072726	A1	3/2014	Kim
2013/0256838	A1	10/2013	Sanchez et al.	2014/0072925	A1	3/2014	Kaneko
				2014/0073143	A1	3/2014	Alokozai et al.
				2014/0076861	A1	3/2014	Cornelius et al.
				2014/0077240	A1	3/2014	Roucka et al.
				2014/0084341	A1	3/2014	Weeks

(56)

References Cited

U.S. PATENT DOCUMENTS

2014/0087544	A1	3/2014	Tolle
2014/0094027	A1	4/2014	Azumo et al.
2014/0096716	A1	4/2014	Chung et al.
2014/0097468	A1	4/2014	Okita
2014/0099794	A1	4/2014	Ingle et al.
2014/0099798	A1	4/2014	Tsuji
2014/0103145	A1	4/2014	White et al.
2014/0106574	A1	4/2014	Kang et al.
2014/0110798	A1	4/2014	Cai
2014/0113457	A1	4/2014	Sims
2014/0116335	A1	5/2014	Tsuji et al.
2014/0117380	A1	5/2014	Loboda et al.
2014/0120487	A1	5/2014	Kaneko
2014/0120678	A1	5/2014	Shinriki et al.
2014/0120723	A1	5/2014	Fu et al.
2014/0120738	A1	5/2014	Jung
2014/0120750	A1	5/2014	Johnson
2014/0127907	A1	5/2014	Yang
2014/0130687	A1	5/2014	Shibusawa et al.
2014/0138779	A1	5/2014	Xie et al.
2014/0141165	A1	5/2014	Sato et al.
2014/0141625	A1	5/2014	Fukazawa et al.
2014/0141674	A1	5/2014	Galbreath et al.
2014/0144500	A1	5/2014	Cao et al.
2014/0145332	A1	5/2014	Ryan et al.
2014/0158786	A1	6/2014	Santo
2014/0159170	A1	6/2014	Raisanen et al.
2014/0162401	A1	6/2014	Kawano et al.
2014/0167187	A1	6/2014	Kuo et al.
2014/0174354	A1	6/2014	Arai
2014/0175054	A1	6/2014	Carlson et al.
2014/0182053	A1	7/2014	Huang
2014/0182689	A1	7/2014	Shareef et al.
2014/0187045	A1	7/2014	Hua et al.
2014/0191389	A1	7/2014	Lee et al.
2014/0193983	A1	7/2014	Lavoie
2014/0202382	A1	7/2014	Kim et al.
2014/0202386	A1	7/2014	Taga
2014/0202388	A1	7/2014	Um et al.
2014/0209976	A1	7/2014	Yang et al.
2014/0217065	A1	8/2014	Winkler et al.
2014/0220247	A1	8/2014	Haukka et al.
2014/0225065	A1	8/2014	Rachmady et al.
2014/0227072	A1	8/2014	Lee et al.
2014/0227444	A1	8/2014	Winter et al.
2014/0227861	A1	8/2014	Wu et al.
2014/0227881	A1	8/2014	Lubomirsky et al.
2014/0231922	A1	8/2014	Kim et al.
2014/0234466	A1	8/2014	Gao et al.
2014/0234550	A1	8/2014	Winter et al.
2014/0234992	A1	8/2014	Kubota et al.
2014/0238608	A1	8/2014	Sabri et al.
2014/0242806	A1	8/2014	Knapp et al.
2014/0245948	A1	9/2014	Nguyen et al.
2014/0251788	A1	9/2014	Ge et al.
2014/0251953	A1	9/2014	Winkler et al.
2014/0251954	A1	9/2014	Winkler et al.
2014/0252134	A1	9/2014	Chen
2014/0252479	A1	9/2014	Utomo et al.
2014/0260684	A1	9/2014	Christmann
2014/0262034	A1	9/2014	Ishibashi et al.
2014/0262193	A1	9/2014	Im et al.
2014/0263272	A1	9/2014	Duan et al.
2014/0264297	A1	9/2014	Kumar et al.
2014/0264902	A1	9/2014	Ting et al.
2014/0272194	A1	9/2014	Xiao et al.
2014/0272341	A1	9/2014	Duan et al.
2014/0273428	A1	9/2014	Shero
2014/0273477	A1	9/2014	Niskanen
2014/0273510	A1	9/2014	Chen et al.
2014/0273528	A1	9/2014	Niskanen
2014/0273530	A1	9/2014	Nguyen
2014/0273531	A1	9/2014	Niskanen
2014/0283747	A1	9/2014	Kasai et al.
2014/0290573	A1	10/2014	Okabe et al.
2014/0306250	A1	10/2014	Gardner et al.
2014/0308108	A1	10/2014	Fosnight et al.
2014/0312767	A1	10/2014	Tian et al.
2014/0322862	A1	10/2014	Xie et al.
2014/0322885	A1	10/2014	Xie et al.
2014/0339981	A1	11/2014	Komatsu et al.
2014/0346142	A1	11/2014	Chapuis et al.
2014/0346650	A1	11/2014	Raisanen et al.
2014/0349033	A1	11/2014	Nonaka et al.
2014/0357090	A1	12/2014	Knaepen et al.
2014/0363980	A1	12/2014	Kawamata et al.
2014/0363983	A1	12/2014	Nakano et al.
2014/0363985	A1	12/2014	Jang et al.
2014/0367043	A1	12/2014	Bishara et al.
2014/0367642	A1	12/2014	Guo
2014/0377960	A1	12/2014	Koiwa
2015/0004316	A1	1/2015	Thompson et al.
2015/0004317	A1	1/2015	Dussarrat et al.
2015/0004798	A1	1/2015	Chandrasekharan et al.
2015/0007770	A1	1/2015	Chandrasekharan et al.
2015/0010381	A1	1/2015	Cai
2015/0011095	A1	1/2015	Chandrasekharan et al.
2015/0014632	A1	1/2015	Kim et al.
2015/0014823	A1	1/2015	Mallikarjunan et al.
2015/0017794	A1	1/2015	Takamure
2015/0021599	A1	1/2015	Ridgeway
2015/0024609	A1	1/2015	Milligan et al.
2015/0030766	A1	1/2015	Lind et al.
2015/0031218	A1	1/2015	Karakawa
2015/0041431	A1	2/2015	Zafiropoulo et al.
2015/0048485	A1	2/2015	Tolle
2015/0056815	A1	2/2015	Fernandez
2015/0056821	A1	2/2015	Ishikawa et al.
2015/0064923	A1	3/2015	Matsumoto et al.
2015/0072509	A1	3/2015	Chi et al.
2015/0078874	A1	3/2015	Sansoni
2015/0079311	A1	3/2015	Nakano
2015/0086316	A1	3/2015	Greenberg
2015/0087154	A1	3/2015	Guha et al.
2015/0091057	A1	4/2015	Xie et al.
2015/0091134	A1	4/2015	Amaratunga et al.
2015/0096973	A1	4/2015	Dunn et al.
2015/0099065	A1	4/2015	Canizares et al.
2015/0099072	A1	4/2015	Takamure et al.
2015/0099342	A1	4/2015	Tsai
2015/0099374	A1	4/2015	Kakimoto et al.
2015/0102466	A1	4/2015	Colinge
2015/0111374	A1	4/2015	Bao
2015/0111395	A1	4/2015	Hashimoto et al.
2015/0114295	A1	4/2015	Kim et al.
2015/0118009	A1	4/2015	Hsieh et al.
2015/0118846	A1	4/2015	Isii et al.
2015/0122180	A1	5/2015	Chang et al.
2015/0125628	A1	5/2015	Kim et al.
2015/0132212	A1	5/2015	Winkler et al.
2015/0140210	A1	5/2015	Jung et al.
2015/0147482	A1	5/2015	Kang et al.
2015/0147483	A1	5/2015	Fukazawa
2015/0147488	A1	5/2015	Choi et al.
2015/0147875	A1	5/2015	Takamure et al.
2015/0147877	A1	5/2015	Jung
2015/0152547	A1	6/2015	Nakamura et al.
2015/0155177	A1	6/2015	Zhang et al.
2015/0162168	A1	6/2015	Oehrlien
2015/0162185	A1	6/2015	Pore
2015/0162214	A1	6/2015	Thompson
2015/0167159	A1	6/2015	Halpin et al.
2015/0167162	A1	6/2015	Barik et al.
2015/0167165	A1	6/2015	Lindfors
2015/0167705	A1	6/2015	Lee et al.
2015/0170914	A1	6/2015	Haukka et al.
2015/0170945	A1	6/2015	Segawa et al.
2015/0170947	A1	6/2015	Bluck
2015/0170954	A1	6/2015	Agarwal
2015/0170975	A1	6/2015	Blatchford et al.
2015/0171177	A1	6/2015	Cheng et al.
2015/0174768	A1	6/2015	Rodnick
2015/0175467	A1	6/2015	Denifl et al.
2015/0176126	A1	6/2015	Ge et al.

(56)

References Cited

U.S. PATENT DOCUMENTS

2019/0233940 A1 8/2019 Guo et al.
 2019/0237327 A1 8/2019 Kohen et al.
 2019/0244803 A1 8/2019 Suzuki
 2019/0249300 A1 8/2019 Hatanpaa et al.
 2019/0249303 A1 8/2019 Kuroda et al.
 2019/0252195 A1 8/2019 Haukka
 2019/0252196 A1 8/2019 Vayrynen et al.
 2019/0259611 A1 8/2019 Nakano et al.
 2019/0259612 A1 8/2019 Nozawa et al.
 2019/0264324 A1 8/2019 Shugrue et al.
 2019/0271078 A1 9/2019 Raisanen et al.
 2019/0272981 A1 9/2019 Xu et al.
 2019/0272993 A1 9/2019 Mattinen et al.
 2019/0273133 A1 9/2019 Agrawal et al.
 2019/0276934 A1 9/2019 Verghese et al.
 2019/0287769 A1 9/2019 Blomberg et al.
 2019/0295837 A1 9/2019 Pore et al.
 2019/0301014 A1 10/2019 Pierreux et al.
 2019/0304776 A1 10/2019 Choi
 2019/0304780 A1 10/2019 Kohen et al.
 2019/0304790 A1 10/2019 Mousa et al.
 2019/0304821 A1 10/2019 Pierreux et al.
 2019/0311897 A1 10/2019 Kang et al.
 2019/0311940 A1 10/2019 Choi et al.
 2019/0318923 A1 10/2019 Blanquart et al.
 2019/0322812 A1 10/2019 Wojtecki et al.
 2019/0330740 A1 10/2019 Klaver
 2019/0333753 A1 10/2019 Ueda et al.
 2019/0333761 A1 10/2019 Tois et al.
 2019/0338418 A1 11/2019 Goradia et al.
 2019/0346300 A1 11/2019 Kim et al.
 2019/0348261 A1 11/2019 Lin et al.
 2019/0348273 A1 11/2019 Tang et al.
 2019/0348515 A1 11/2019 Li et al.
 2019/0363006 A1 11/2019 Min
 2019/0368040 A1 12/2019 Kachel et al.
 2019/0368041 A1 12/2019 Sreeram et al.
 2019/0371594 A1 12/2019 Niskanen et al.
 2019/0371640 A1 12/2019 Raisanen et al.
 2019/0375638 A1 12/2019 Haukka
 2019/0376180 A1 12/2019 Niskanen
 2019/0378916 A1 12/2019 Tang et al.
 2019/0390338 A1 12/2019 Raisanen et al.
 2019/0390343 A1 12/2019 Min et al.
 2019/0393308 A1 12/2019 Lo et al.
 2020/0002811 A1 1/2020 Sreeram et al.
 2020/0002812 A1 1/2020 Lee et al.
 2020/0013612 A1 1/2020 Blanquart et al.
 2020/0013613 A1 1/2020 Blanquart
 2020/0013626 A1 1/2020 Longrie et al.
 2020/0013629 A1 1/2020 de Roest et al.
 2020/0018421 A1 1/2020 Shugrue
 2020/0040458 A1 2/2020 Ma et al.
 2020/0048768 A1 2/2020 Wieggers et al.
 2020/0056282 A1 2/2020 Raisanen et al.
 2020/0056286 A1 2/2020 Shero et al.
 2020/0064737 A1 2/2020 de Roest
 2020/0066552 A1 2/2020 Susa
 2020/0080200 A1 3/2020 Um et al.
 2020/0083054 A1 3/2020 Väyrynen et al.
 2020/0083375 A1 3/2020 Tolle et al.
 2020/0083469 A1 3/2020 Lhullier
 2020/0102649 A1 4/2020 Reed
 2020/0102653 A1 4/2020 Muralidhar et al.
 2020/0105579 A1 4/2020 Zhu
 2020/0109472 A1 4/2020 Um et al.
 2020/0111669 A1 4/2020 Zaitso et al.
 2020/0111690 A1 4/2020 Oosterlaken
 2020/0118811 A1 4/2020 Utsuno et al.
 2020/0118815 A1 4/2020 Fukazawa et al.
 2020/0118817 A1 4/2020 Blomberg et al.
 2020/0126771 A1 4/2020 Roh et al.
 2020/0126840 A1 4/2020 Roh et al.
 2020/0131634 A1 4/2020 Gao et al.
 2020/0135512 A1 4/2020 Oosterlaken et al.

2020/0140995 A1 5/2020 Blanquart et al.
 2020/0141003 A1 5/2020 Lee et al.
 2020/0144058 A1 5/2020 Kohen
 2020/0161129 A1 5/2020 Mattinen et al.
 2020/0161438 A1 5/2020 Tang et al.
 2020/0168485 A1 5/2020 Fluit
 2020/0173020 A1 6/2020 Huggare
 2020/0176244 A1 6/2020 Lee et al.
 2020/0176246 A1 6/2020 Huotari et al.
 2020/0181770 A1 6/2020 Longrie et al.
 2020/0194253 A1 6/2020 Banerjee et al.
 2020/0194268 A1 6/2020 Sharma

FOREIGN PATENT DOCUMENTS

CN 2588350 11/2003
 CN 1563483 1/2005
 CN 1655362 8/2005
 CN 1664987 9/2005
 CN 1825535 8/2006
 CN 101142012 3/2008
 CN 101681873 3/2010
 CN 102383106 3/2012
 CN 103014846 4/2013
 CN 102373440 7/2014
 CN 104244620 12/2014
 CN 108389798 8/2018
 DE 3836696 12/1989
 DE 10133013 1/2003
 DE 102008052750 6/2009
 EP 0887632 12/1998
 EP 1889817 2/2008
 EP 2036600 3/2009
 EP 2426233 7/2012
 FR 1408266 8/1965
 FR 2233614 1/1975
 GB 752-277 7/1956
 GB 1186889 6/1966
 JP 58-19462 4/1983
 JP 59-211779 11/1984
 JP 61038863 2/1986
 JP S62237236 10/1987
 JP H01-296613 11/1989
 JP H01-307229 12/1989
 JP H02-93071 4/1990
 JP H02-185038 7/1990
 JP H03-044472 2/1991
 JP H03-155625 7/1991
 JP H03-248427 11/1991
 JP H04-29313 1/1992
 JP H04-115531 4/1992
 JP H05-23079 3/1993
 JP H05-118928 5/1993
 JP H05-171446 7/1993
 JP H05-291142 11/1993
 JP H06-053210 2/1994
 JP H06-84888 3/1994
 JP 6204231 7/1994
 JP H06-319177 11/1994
 JP H06-338497 12/1994
 JP H07-297271 1/1995
 JP H0729836 1/1995
 JP H07-109576 4/1995
 JP H07-034936 8/1995
 JP H07-225214 8/1995
 JP 7-272694 10/1995
 JP H07-283149 10/1995
 JP H07-209093 11/1995
 JP H08-181135 7/1996
 JP H08-335558 12/1996
 JP H09-064149 3/1997
 JP 9-89676 4/1997
 JP H09-148322 6/1997
 JP H10-41096 2/1998
 JP H10-50800 2/1998
 JP H10-064696 3/1998
 JP H10-153494 6/1998
 JP H10-227703 8/1998
 JP H10-0261620 9/1998

(56)	References Cited					
	FOREIGN PATENT DOCUMENTS					
				JP	2013235912	11/2013
				JP	2015115461	6/2015
				JP	2016098406	5/2016
				JP	2010123843	6/2016
				JP	2016174158	9/2016
				JP	2017183242	10/2017
				JP	6519897	5/2019
				KR	1998-0026850	7/1998
				KR	10-0253664	4/2000
				KR	10-2000-0031098	6/2000
				KR	10-2000-0045257	7/2000
				KR	10-0295043	4/2001
				KR	10-2002-0064028	8/2002
				KR	2002-0086763	11/2002
				KR	10-0377095	3/2003
				KR	2003-0092305	12/2003
				KR	10-2005-0054122	6/2005
				KR	10-0547248	1/2006
				KR	10-0593960	6/2006
				KR	10-0688484	2/2007
				KR	10-2007-0084683	8/2007
				KR	20080058620	6/2008
				KR	10-2009-0055443	6/2009
				KR	10-2009-0086790	8/2009
				KR	10-2010-0020834	2/2010
				KR	10-2010-0032812	3/2010
				KR	10-2010-0079920	7/2010
				KR	10-2011-0058534	6/2011
				KR	10-1114219	3/2012
				KR	10-2012-0111060	10/2012
				KR	101491726	2/2015
				KR	10-1535573	7/2015
				SU	494614	2/1976
				SU	1408319	7/1988
				TW	538327	6/2003
				TW	540093	7/2003
				TW	M292692	6/2006
				TW	200731357	8/2007
				TW	201247690	12/2012
				TW	201330086	7/2013
				WO	1991004522	4/1991
				WO	1996017107	6/1996
				WO	1997003223	1/1997
				WO	1998032893	7/1998
				WO	1999023690	5/1999
				WO	DM/048579	7/1999
				WO	2004008491	7/2002
				WO	2004008827	1/2004
				WO	2004010467	1/2004
				WO	2004106584	12/2004
				WO	2006054854	12/2004
				WO	2005112082	11/2005
				WO	2006035281	4/2006
				WO	2006056091	6/2006
				WO	2006078666	7/2006
				WO	2006080782	8/2006
				WO	2006097525	9/2006
				WO	2006101857	9/2006
				WO	2006114781	11/2006
				WO	2007024720	3/2007
				WO	2007027165	3/2007
				WO	2007076195	7/2007
				WO	2007117718	10/2007
				WO	2007131051	11/2007
				WO	2007140376	12/2007
				WO	2008045972	4/2008
				WO	2008091900	7/2008
				WO	2008121463	10/2008
				WO	2008147731	12/2008
				WO	2009028619	3/2009
				WO	2009029532	3/2009
				WO	2009039251	3/2009
				WO	2009099776	8/2009
				WO	2009154889	12/2009
				WO	2009154896	12/2009
				WO	2010039363	4/2010
				WO	2010077533	7/2010
				WO	2010100702	9/2010
				WO	2010118051	10/2010

(56)

References Cited

FOREIGN PATENT DOCUMENTS

WO	2010129428	11/2010
WO	2010129430	11/2010
WO	2010129431	11/2010
WO	2011019950	2/2011
WO	2011149640	12/2011
WO	2012056592	5/2012
WO	2012077590	6/2012
WO	2013043330	3/2013
WO	2013078065	5/2013
WO	2013078066	5/2013
WO	2014107290	7/2014
WO	2015026230	2/2015
WO	2015107009	7/2015
WO	2018109553	6/2016
WO	2018109554	6/2016
WO	2015112728	6/2017
WO	2017108713	6/2017
WO	2017108714	6/2017
WO	2017212546	12/2017
WO	2018003072	1/2018
WO	2018008088	1/2018
WO	2018013778	1/2018
WO	2018020316	2/2018
WO	2018020318	2/2018
WO	2018020320	2/2018
WO	2018020327	2/2018
WO	2018105349	6/2018
WO	2018109551	6/2018
WO	2018109552	6/2018
WO	2018178771	10/2018
WO	2019030565	2/2019
WO	2019103610	5/2019
WO	2019103613	5/2019
WO	2019142055	7/2019
WO	2019158960	8/2019
WO	2019217749	11/2019
WO	2019229537	12/2019
WO	2020002995	1/2020
WO	2020003000	1/2020

OTHER PUBLICATIONS

CNIPA; Office Action dated Aug. 1, 2013 in Application No. 201080015699.9.
 CNIPA; Office Action dated Jan. 21, 2014 in Application No. 201080015699.9.
 CNIPA; Office Action dated Jul. 25, 2014 in Application No. 201080015699.9.
 CNIPA; Office Action dated Jan. 12, 2015 in Application No. 201080015699.9.
 CNIPA; Notice of Allowance dated May 8, 2015 in Application No. 201080015699.9.
 CNIPA; Office Action dated Dec. 10, 2013 in Application No. 201080020267.7.
 CNIPA; Notice of Allowance dated Aug. 22, 2014 in Application No. 201080020267.7.
 CNIPA; Office Action dated Jan. 21, 2013 in Application No. 201080020268.1.
 CNIPA; Office Action dated Sep. 26, 2013 in Application No. 201080020268.1.
 CNIPA; Office Action dated Apr. 3, 2014 in Application No. 201080020268.1.
 CNIPA; Office Action dated Sep. 23, 2014 in Application No. 201080020268.1.
 CNIPA; Office Action dated Apr. 7, 2015 in Application No. 201080020268.1.
 CNIPA; Notice of Allowance dated Oct. 16, 2015 in Application No. 201080020268.1.
 CNIPA; Office Action dated May 24, 2013 in Application No. 201080036764.6.

CNIPA; Office Action dated Jan. 2, 2014 in Application No. 201080036764.6.
 CNIPA; Office Action dated Jul. 1, 2014 in Application No. 201080036764.6.
 CNIPA; Notice of Allowance dated Oct. 24, 2014 in Application No. 201080036764.6.
 CNIPA; Office Action dated Feb. 8, 2014 in Application No. 201110155056.0.
 CNIPA; Office Action dated Sep. 16, 2014 in Application No. 201110155056.0.
 CNIPA; Office Action dated Feb. 9, 2015 in Application No. 201110155056.0.
 CNIPA; Notice of Allowance dated Aug. 26, 2015 in Application No. 201110155056.0.
 CNIPA; Office Action dated Dec. 4, 2015 in Application No. 201210201995.9.
 CNIPA; Office Action dated Jul. 14, 2016 in Application No. 201210201995.9.
 CNIPA; Office Action dated Jan. 20, 2017 in Application No. 201210201995.9.
 CNIPA; Notice of Allowance dated Apr. 13, 2017 in Application No. 201210201995.9.
 CNIPA; Office Action dated Dec. 24, 2015 in Application No. 201280057466.4.
 CNIPA; Notice of Allowance dated Jun. 16, 2016 in Application No. 201280057466.4.
 CNIPA; Office Action dated Dec. 4, 2015 in Application No. 201280057542.1.
 CNIPA; Office Action dated May 16, 2016 in Application No. 201280057542.1.
 CNIPA; Office Action dated Sep. 9, 2016 in Application No. 201280057542.1.
 CNIPA; Notice of Allowance dated Jan. 3, 2017 in Application No. 201280057542.1.
 CNIPA; Office Action dated Dec. 5, 2016 in Application No. 201310412808.6.
 CNIPA; Notice of Allowance dated Jul. 20, 2017 in Application No. 201310412808.6.
 CNIPA; Office Action dated Feb. 5, 2018 in Application No. 201410331047.6.
 CNIPA; Office Action dated Dec. 14, 2018 in Application No. 201410331047.6.
 CNIPA; Notice of Allowance dated Jun. 14, 2019 in Application No. 201410331047.6.
 CNIPA; Office Action dated Oct. 19, 2018 in Application No. 201510765170.3.
 CNIPA; Office Action dated Jun. 28, 2019 in Application No. 201510765170.3.
 CNIPA; Notice of Allowance dated Sep. 30, 2019 in Application No. 201510765170.3.
 CNIPA; Office Action dated Oct. 31, 2018 in Application No. 201510765406.3.
 CNIPA; Office Action dated Jun. 28, 2019 in Application No. 201510765406.3.
 CNIPA; Notice of Allowance dated Dec. 27, 2019 in Application No. 201510765406.3.
 CNIPA; Office Action dated Jan. 21, 2020 in Application No. 201610028064.1.
 CNIPA; Office Action dated Mar. 14, 2019 in Application No. 201610141027.1.
 CNIPA; Notice of Allowance dated Sep. 3, 2019 in Application No. 201610141027.1.
 CNIPA; Office Action dated Jul. 23, 2019 in Application No. 201610897958.4.
 CNIPA; Office Action dated Feb. 28, 2020 in Application No. 201610897958.4.
 CNIPA; Office Action dated Nov. 4, 2019 in Application No. 201610898822.5.
 CNIPA; Office Action dated Dec. 20, 2018 in Application No. 201710738549.4.
 CNIPA; Office Action dated Jun. 20, 2019 in Application No. 201711120632.1.

(56)

References Cited

OTHER PUBLICATIONS

CNIPA; Notice of Allowance dated May 25, 2017 in Application No. 201730010308.9.
CNIPA; Office Action dated Nov. 11, 2019 in Application No. 201810379112.0.
CNIPA; Notice of Allowance dated Oct. 24, 2018 in Application No. 201830060972.9.
CNIPA; Notice of Allowance dated Nov. 1, 2018 in Application No. 201830397219.9.
EPO; Supplementary European Search Report and Opinion dated Nov. 9, 2012 in Application No. 08798519.8.
EPO; Office Action dated Jul. 18, 2016 in Application No. 08798519.8.
EPO; Extended European Search Report dated Dec. 9, 2016 in Application No. 09767208.3.
EPO; Office Action dated Aug. 10, 2018 in Application No. 09767208.3.
EPO; Notice of Allowance dated Aug. 1, 2019 in Application No. 09767208.3.
EPO; Supplementary European Search Report and Opinion dated Jan. 5, 2017 in Application No. 09836647.9.
EPO; Office Action dated Feb. 28, 2018 in Application No. 09836647.9.
EPO; Office Action dated Jan. 11, 2019 in Application No. 09836647.9.
EPO; Notice of Allowance dated Oct. 16, 2019 in Application No. 09836647.9.
EPO; Extended European Search Report dated Apr. 28, 2014 in Application No. 11162225.4.
EPO; Notice of Allowance dated Feb. 3, 2015 in Application No. 11162225.4.
EPO; Extended European Search Report dated Nov. 29, 2019 in Application No. 19188826.2.
EPO; Extended European Search Report dated Mar. 3, 2020 in Application No. 19205558.0.
IPOS; Notice of Allowance dated Aug. 14, 2017 in Application No. 10201401237.
JPO; Office Action dated Aug. 10, 2009 in Application No. 2003029767.
JPO; Office Action dated Apr. 13, 2010 in Application No. 2003029767.
JPO; Notice of Allowance dated Jun. 24, 2010 in Application No. 2003029767.
JPO; Office Action dated Oct. 30, 2008 in Application No. 2004558313.
JPO; Office Action dated Feb. 19, 2009 in Application No. 2004558313.
JPO; Notice of Allowance dated Jun. 30, 2009 in Application No. 2004558313.
JPO; Office Action dated Mar. 16, 2012 in Application No. 2009-532567.
JPO; Notice of Allowance dated Jul. 23, 2012 in Application No. 2009-532567.
JPO; Notice of Allowance dated Mar. 29, 2013 in Application No. 2010-509478.
JPO; Office Action dated Dec. 20, 2011 in Application No. 2010-522075.
JPO; Office Action dated Apr. 11, 2012 in Application No. 2010-522075.
JPO; Office Action dated May 15, 2013 in Application No. 2010058415.
JPO; Office Action dated Oct. 30, 2013 in Application No. 2010058415.
JPO; Office Action dated Aug. 7, 2014 in Application No. 2010058415.
JPO; Notice of Allowance dated Dec. 18, 2014 in Application No. 2010058415.
JPO; Office Action dated Aug. 22, 2013 in Application No. 2010-153754.
JPO; Office Action dated Oct. 30, 2013 in Application No. 2010-193285.
JPO; Office Action dated Aug. 26, 2015 in Application No. 2011-284831.
JPO; Notice of Allowance dated Mar. 3, 2016 in Application No. 2011-284831.
JPO; Office Action dated May 31, 2012 in Application No. 2011-514650.

JPO; Office Action dated Sep. 11, 2012 in Application No. 2011-514650.
JPO; Notice of Allowance dated Dec. 10, 2012 in Application No. 2011-514650.
JPO; Office Action dated Dec. 10, 2014 in Application No. 2011090067.
JPO; Notice of Allowance dated Apr. 28, 2015 in Application No. 2011090067.
JPO; Office Action dated Jul. 14, 2016 in Application No. 2012-153698.
JPO; Notice of Allowance dated Oct. 21, 2016 in Application No. 2012-153698.
JPO; Office Action dated Dec. 20, 2013 in Application No. 2012-504786.
JPO; Office Action dated Jan. 25, 2014 in Application No. 2012-504786.
JPO; Office Action dated Dec. 1, 2014 in Application No. 2012-504786.
JPO; Notice of Allowance dated Jun. 12, 2015 in Application No. 2012504786.
JPO; Office Action dated Mar. 11, 2013 in Application No. 2012-509857.
JPO; Notice of Allowance dated Jun. 29, 2013 in Application No. 2012-509857.
JPO; Office Action dated May 19, 2017 in Application No. 2013-160173.
JPO; Notice of Allowance dated Aug. 23, 2017 in Application No. 2013-160173.
JPO; Office Action dated Aug. 14, 2017 in Application No. 2013-178344.
JPO; Office Action dated Jan. 23, 2018 in Application No. 2013-178344.
JPO; Notice of Allowance dated Jul. 24, 2018 in Application No. 2013-178344.
JPO; Office Action dated Apr. 3, 2018 in Application No. 2014-120675.
JPO; Notice of Allowance dated Jun. 6, 2018 in Application No. 2014-120675.
JPO; Office Action dated Mar. 28, 2018 in Application No. 2014-188835.
JPO; Notice of Allowance dated Jun. 6, 2018 in Application No. 2014-188835.
JPO; Office Action dated Apr. 12, 2018 in Application No. 2014-205548.
JPO; Notice of Allowance dated Dec. 19, 2019 in Application No. 2014205548.
JPO; Notice of Allowance dated May 14, 2018 in Application No. 2014-216540.
JPO; Office Action dated Jul. 20, 2018 in Application No. 2015-034774.
JPO; Office Action dated Jun. 27, 2019 in Application No. 2015034774.
JPO; Notice of Allowance dated Nov. 20, 2019 in Application No. 2015034774.
JPO; Office Action dated Jan. 30, 2019 in Application No. 2015052198.
JPO; Notice of Allowance dated Apr. 5, 2019 in Application No. 2015052198.
JPO; Office Action dated Aug. 29, 2019 in Application No. 2016001928.
JPO; Notice of Allowance dated Dec. 17, 2019 in Application No. 2016001928.
KIPO; Office Action dated Dec. 10, 2015 in Application No. 10-2010-0028336.
KIPO; Office Action dated Jun. 29, 2016 in Application No. 10-2010-0028336.
KIPO; Notice of Allowance dated Sep. 29, 2016 in Application No. 10-2010-0028336.
KIPO; Office Action dated Mar. 3, 2016 in Application No. 10-2010-0067768.
KIPO; Office Action dated Aug. 1, 2016 in Application No. 10-2010-0067768.
KIPO; Notice of Allowance dated Dec. 1, 2016 in Application No. 10-2010-0067768.
KIPO; Office Action dated May 2, 2016 in Application No. 10-2010-0082446.

(56)

References Cited

OTHER PUBLICATIONS

KIPO; Office Action dated Sep. 19, 2016 in Application No. 10-2010-0082446.
 KIPO; Notice of Allowance dated Mar. 7, 2017 in Application No. 10-2010-0082446.
 KIPO; Office Action dated Mar. 13, 2017 in Application No. 20110034612.
 KIPO; Office Action dated Jul. 20, 2017 in Application No. 20110034612.
 KIPO; Notice of Allowance dated Sep. 1, 2017 in Application No. 20110034612.
 KIPO; Office Action dated Nov. 24, 2017 in Application No. 10-2011-0036449.
 KIPO; Office Action dated May 23, 2017 in Application No. 10-2011-0036449.
 KIPO; Office Action dated Apr. 2, 2018 in Application No. 10-2011-0036449.
 KIPO; Notice of Allowance dated Oct. 24, 2018 in Application No. 10-2011-0036449.
 KIPO; Office Action dated Sep. 4, 2017 in Application No. 10-2011-0087600.
 KIPO; Notice of Allowance dated Jan. 11, 2018 in Application No. 10-2011-0087600.
 KIPO; Office Action dated Oct. 23, 2017 in Application No. 10-2011-0142924.
 KIPO; Notice of Allowance dated Mar. 14, 2018 in Application No. 10-2011-0142924.
 KIPO; Office Action dated Dec. 11, 2015 in Application No. 10-2011-7023416.
 KIPO; Office Action dated Mar. 13, 2016 in Application No. 10-2011-7023416.
 KIPO; Notice of Allowance dated Jun. 2, 2016 in Application No. 10-2011-7023416.
 KIPO; Office Action dated Oct. 30, 2017 in Application No. 10-2012-0041878.
 KIPO; Notice of Allowance dated Feb. 28, 2018 in Application No. 10-2012-0041878.
 KIPO; Office Action dated Mar. 21, 2018 in Application No. 10-2012-0042518.
 KIPO; Notice of Allowance dated May 30, 2018 in Application No. 10-2012-0042518.
 KIPO; Office Action dated Mar. 21, 2018 in Application No. 10-2012-0064526.
 KIPO; Office Action dated Sep. 18, 2018 in Application No. 10-2012-0064526.
 KIPO; Office Action dated Dec. 13, 2018 in Application No. 10-2012-0064526.
 KIPO; Office Action dated Jan. 12, 2019 in Application No. 10-2012-0064526.
 KIPO; Notice of Allowance dated Jul. 5, 2019 in Application No. 10-2012-0064526.
 KIPO; Office Action dated Mar. 30, 2018 in Application No. 10-2012-0076564.
 KIPO; Office Action dated Sep. 27, 2018 in Application No. 10-2012-0076564.
 KIPO; Office Action dated Mar. 27, 2019 in Application No. 10-2012-0076564.
 KIPO; Office Action dated Apr. 30, 2018 in Application No. 10-2012-0103114.
 KIPO; Notice of Allowance dated Nov. 22, 2018 in Application No. 10-2012-0103114.
 KIPO; Office Action dated Oct. 24, 2016 in Application No. 10-2012-7004062.
 KIPO; Office Action dated Jul. 24, 2017 in Application No. 10-2012-7004062.
 KIPO; Decision of Intellectual Property Trial and Appeal Board dated May 13, 2019 in Application No. 10-2012-7004062.
 KIPO; Office Action dated May 30, 2019 in Application No. 10-2012-7004062.

KIPO; Notice of Allowance dated Sep. 27, 2019 in Application No. 10-2012-7004062.
 KIPO; Office Action dated Feb. 28, 2020 in Application No. 10-2013-0049598.
 KIPO; Notice of Allowance dated Feb. 27, 2020 in Application No. 10-2013-0089998.
 KIPO; Office Action dated Apr. 19, 2019 in Application No. 10-2013-0101944.
 KIPO; Notice of Allowance dated Mar. 4, 2020 in Application No. 10-2013-0114079.
 KIPO; Office Action dated Apr. 24, 2019 in Application No. 10-2013-0036823.
 KIPO; Notice of Allowance dated Aug. 29, 2019 in Application No. 10-2013-0036823.
 KIPO; Office Action dated Aug. 27, 2019 in Application No. 10-2013-0049598.
 KIPO; Office Action dated May 31, 2019 in Application No. 10-2013-0050740.
 KIPO; Office Action dated Nov. 27, 2019 in Application No. 10-2013-0050740.
 KIPO; Office Action dated Mar. 27, 2019 in Application No. 10-2013-0084459.
 KIPO; Notice of Allowance dated Oct. 30, 2019 in Application No. 10-2013-0084459.
 KIPO; Office Action dated Apr. 30, 2019 in Application No. 10-2013-0088450.
 KIPO; Office Action dated Nov. 29, 2019 in Application No. 10-2013-0088450.
 KIPO; Notice of Allowance dated Jan. 13, 2020 in Application No. 10-2013-0088450.
 KIPO; Office Action dated Aug. 27, 2019 in Application No. 10-2013-0089998.
 KIPO; Office Action dated Dec. 4, 2019 in Application No. 10-2013-0098575.
 KIPO; Notice of Allowance dated Oct. 8, 2019 in Application No. 10-2013-0101944.
 KIPO; Office Action dated Nov. 12, 2019 in Application No. 10-2013-0102026.
 KIPO; Office Action dated Aug. 15, 2019 in Application No. 10-2013-0109390.
 KIPO; Notice of Allowance dated Oct. 21, 2019 in Application No. 10-2013-0109390.
 KIPO; Office Action dated Oct. 7, 2019 in Application No. 10-2013-0114079.
 KIPO; Office Action dated May 21, 2019 in Application No. 10-2013-0121554.
 KIPO; Notice of Allowance dated Oct. 28, 2019 in Application No. 10-2013-0121554.
 KIPO; Office Action dated Mar. 30, 2020 in Application No. 10-2014-0011764.
 KIPO; Office Action dated Feb. 3, 2020 in Application No. 10-2014-0021615.
 KIPO; Office Action dated Feb. 15, 2020 in Application No. 10-2014-0027305.
 KIPO; Office Action dated Mar. 11, 2020 in Application No. 10-2014-0103853.
 KIPO; Office Action dated Jan. 22, 2019 in Application No. 10-2014-7017110.
 KIPO; Notice of Allowance dated Aug. 26, 2019 in Application No. 10-2014-7017110.
 KIPO; Office Action dated Sep. 28, 2017 in Application No. 10-2014-7017112.
 KIPO; Notice of Allowance dated Feb. 23, 2018 in Application No. 10-2014-7017112.
 KIPO; Office Action dated Nov. 9, 2016 in Application No. 10-2016-7023913.
 KIPO; Notice of Allowance dated May 30, 2017 in Application No. 10-2016-7023913.
 KIPO; Notice of Allowance dated Feb. 27, 2018 in Application No. 10-2017-0175442.
 KIPO; Office Action dated Sep. 28, 2017 in Application No. 10-2017-7023740.

(56)

References Cited

OTHER PUBLICATIONS

KIPO; Final Office Action dated Jun. 17, 2019 in Application No. 10-2017-7023740.
 KIPO; Notice of Allowance dated Jul. 19, 2018 in Application No. 20187013945.
 KIPO; Notice of Allowance dated Nov. 29, 2019 in Application No. 10-2019-0127773.
 KIPO; Office Action dated Feb. 12, 2020 in Application No. 10-2020-7000992.
 KIPO; Office Action dated Sep. 15, 2017 in Application No. 30-2017-0001320.
 KIPO; Notice of Allowance dated Jan. 19, 2018 in Application No. 30-2017-0001320.
 KIPO; Notice of Allowance dated Jul. 10, 2018 in Application No. 30-2017-0052872.
 KIPO; Office Action dated Jul. 11, 2018 in Application No. 30-2018-0006016.
 KIPO; Notice of Allowance dated Oct. 16, 2018 in Application No. 30-2018-0006016.
 KIPO; Office Action dated Jan. 30, 2019 in Application No. 30-2018-0033442.
 KIPO; Notice of Allowance dated Apr. 1, 2019 in Application No. 30-2018-0033442.
 TIPO; Office Action dated Aug. 30, 2013 in Application No. 97132391.
 TIPO; Office Action dated Dec. 20, 2013 in Application No. 98117513.
 TIPO; Notice of Allowance dated Jun. 12, 2014 in Application No. 98117513.
 TIPO; Office Action dated Jul. 4, 2014 in Application No. 99110511.
 TIPO; Notice of Allowance dated Feb. 24, 2016 in Application No. 99110511.
 TIPO; Office Action dated Aug. 27, 2014 in Application No. 99114329.
 TIPO; Notice of Allowance dated Jan. 28, 2015 in Application No. 99114329.
 TIPO; Office Action dated Dec. 26, 2014 in Application No. 99114330.
 TIPO; Notice of Allowance dated Apr. 28, 2015 in Application No. 99114330.
 TIPO; Office Action dated Aug. 14, 2014 in Application No. 99114331.
 TIPO; Notice of Allowance dated Oct. 16, 2015 in Application No. 99114331.
 TIPO; Office Action dated Dec. 19, 2014 in Application No. 99127063.
 TIPO; Notice of Allowance dated Mar. 14, 2016 in Application No. 99127063.
 TIPO; Notice of Allowance dated Oct. 2, 2015 in Application No. 100130472.
 TIPO; Office Action dated Feb. 19, 2016 in Application No. 100113130.
 TIPO; Notice of Allowance dated Jun. 29, 2016 in Application No. 100113130.
 TIPO; Notice of Allowance dated Nov. 2, 2016 in Application No. 101142581.
 TIPO; Office Action dated Apr. 28, 2016 in Application No. 101142582.
 TIPO; Notice of Allowance dated Aug. 19, 2016 in Application No. 101142582.
 TIPO; Office Action dated Aug. 1, 2016 in Application No. 101124745.
 TIPO; Notice of Allowance dated Oct. 19, 2016 in Application No. 101124745.
 TIPO; Office Action dated Sep. 19, 2016 in Application No. 102113028.
 TIPO; Notice of Allowance dated Feb. 13, 2017 in Application No. 102113028.
 TIPO; Office Action dated Aug. 2016 in Application No. 102115605.
 TIPO; Office Action dated Feb. 24, 2017 in Application No. 102115605.

TIPO; Notice of Allowance dated Dec. 26, 2017 in Application No. 102115605.
 TIPO; Office Action dated Nov. 15, 2016 in Application No. 102125191.
 TIPO; Office Action dated Jun. 20, 2017 in Application No. 102125191.
 TIPO; Notice of Allowance dated Feb. 20, 2020 in Application No. 102125191.
 TIPO; Office Action dated Dec. 6, 2016 in Application No. 102126071.
 TIPO; Office Action dated May 17, 2018 in Application No. 102126071.
 TIPO; Notice of Allowance dated Aug. 24, 2018 in Application No. 102126071.
 TIPO; Office Action dated Feb. 10, 2017 in Application No. 102127065.
 TIPO; Notice of Allowance dated Jul. 18, 2017 in Application No. 102127065.
 TIPO; Office Action dated Nov. 3, 2016 in Application No. 102129262.
 TIPO; Notice of Allowance dated Mar. 3, 2017 in Application No. 102129262.
 TIPO; Office Action dated Dec. 29, 2016 in Application No. 102129397.
 TIPO; Notice of Allowance dated Aug. 29, 2017 in Application No. 102129397.
 TIPO; Office Action dated Nov. 3, 2016 in Application No. 102131839.
 TIPO; Notice of Allowance dated Jan. 26, 2017 in Application No. 102131839.
 TIPO; Office Action dated Dec. 2, 2016 in Application No. 102136496.
 TIPO; Office Action dated Jan. 10, 2018 in Application No. 102136496.
 TIPO; Office Action dated Aug. 16, 2019 in Application No. 102136496.
 TIPO; Notice of Allowance dated Jan. 7, 2020 in Application No. 102136496.
 TIPO; Office Action dated Nov. 11, 2016 in Application No. 102132952.
 TIPO; Notice of Allowance dated Apr. 19, 2017 in Application No. 102132952.
 TIPO; Office Action dated Jul. 17, 2017 in Application No. 103101400.
 TIPO; Notice of Allowance dated Jan. 24, 2018 in Application No. 103101400.
 TIPO; Office Action dated Feb. 23, 2017 in Application No. 103102563.
 TIPO; Notice of Allowance dated Nov. 30, 2017 in Application No. 103102563.
 TIPO; Office Action dated Mar. 3, 2017 in Application No. 103105251.
 TIPO; Notice of Allowance dated Oct. 20, 2017 in Application No. 103105251.
 TIPO; Office Action dated Nov. 1, 2017 in Application No. 103106021.
 TIPO; Notice of Allowance dated Apr. 10, 2018 in Application No. 103106021.
 TIPO; Office Action dated Oct. 31, 2017 in Application No. 103106022.
 TIPO; Notice of Allowance dated Apr. 10, 2018 in Application No. 103106022.
 TIPO; Office Action dated Jul. 5, 2017 in Application No. 103117477.
 TIPO; Notice of Allowance dated Jan. 22, 2018 in Application No. 103117477.
 TIPO; Office Action dated Nov. 22, 2017 in Application No. 103117478.
 TIPO; Notice of Allowance dated Mar. 13, 2018 in Application No. 103117478.
 TIPO; Office Action dated May 19, 2017 in Application No. 103120478.
 TIPO; Notice of Allowance dated Sep. 25, 2017 in Application No. 103120478.
 TIPO; Office Action dated Sep. 20, 2018 in Application No. 103123439.
 TIPO; Notice of Allowance dated Jul. 10, 2019 in Application No. 103123439.
 TIPO; Office Action dated Nov. 8, 2017 in Application No. 103124509.
 TIPO; Notice of Allowance dated Apr. 25, 2018 in Application No. 103124509.
 TIPO; Office Action dated Nov. 20, 2017 in Application No. 103127588.

(56)

References Cited

OTHER PUBLICATIONS

- TIPO; Notice of Allowance dated Jun. 19, 2018 in Application No. 103127588.
TIPO; Office Action dated Sep. 19, 2017 in Application No. 103127734.
TIPO; Notice of Allowance dated Dec. 11, 2017 in Application No. 103127734.
TIPO; Office Action dated Sep. 26, 2018 in Application No. 103132230.
TIPO; Notice of Allowance dated Jan. 29, 2019 in Application No. 103132230.
TIPO; Office Action dated Nov. 22, 2017 in Application No. 103134537.
TIPO; Notice of Allowance dated Apr. 19, 2018 in Application No. 103134537.
TIPO; Office Action dated Aug. 24, 2017 in Application No. 103136251.
TIPO; Notice of Allowance dated Oct. 17, 2017 in Application No. 103136251.
TIPO; Office Action dated Feb. 26, 2018 in Application No. 103138510.
TIPO; Notice of Allowance dated Jun. 13, 2018 in Application No. 103138510.
TIPO; Office Action dated May 21, 2018 in Application No. 103139014.
TIPO; Notice of Allowance dated Sep. 11, 2018 in Application No. 103139014.
TIPO; Office Action dated Jun. 22, 2018 in Application No. 104105533.
TIPO; Office Action dated Feb. 22, 2019 in Application No. 104105533.
TIPO; Notice of Allowance dated Sep. 27, 2019 in Application No. 104105533.
TIPO; Office Action dated Nov. 19, 2018 in Application No. 104105965.
TIPO; Notice of Allowance dated Sep. 23, 2019 in Application No. 104105965.
TIPO; Office Action dated Jul. 9, 2018 in Application No. 104107876.
TIPO; Notice of Allowance dated May 9, 2019 in Application No. 104107876.
TIPO; Office Action dated Aug. 7, 2018 Application No. 104107888.
TIPO; Notice of Allowance dated Apr. 26, 2019 in Application No. 104107888.
TIPO; Office Action dated May 6, 2019 in Application No. 104108277.
TIPO; Office Action dated Jan. 17, 2020 in Application No. 104108277.
TIPO; Office Action dated Jul. 9, 2018 in Application No. 104110326.
TIPO; Notice of Allowance dated May 8, 2019 in Application No. 104110326.
TIPO; Office Action dated Jun. 13, 2018 in Application No. 104111910.
TIPO; Notice of Allowance dated Sep. 18, 2018 in Application No. 104111910.
TIPO; Office Action dated Apr. 29, 2019 in Application No. 104122889.
TIPO; Notice of Allowance dated Oct. 4, 2019 in Application No. 104122889.
TIPO; Office Action dated Jan. 30, 2019 in Application No. 104122890.
TIPO; Notice of Allowance dated Jul. 19, 2019 in Application No. 104122890.
TIPO; Office Action dated Jul. 11, 2018 in Application No. 104124377.
TIPO; Notice of Allowance dated Jun. 19, 2019 in Application No. 104124377.
TIPO; Office Action dated Jan. 7, 2019 in Application No. 104132991.
TIPO; Notice of Allowance dated Apr. 12, 2019 in Application No. 104132991.
TIPO; Office Action dated Apr. 25, 2019 in Application No. 104141679.
TIPO; Notice of Allowance dated Nov. 27, 2019 in Application No. 104141679.
TIPO; Office Action dated Apr. 25, 2019 in Application No. 105101536.
TIPO; Office Action dated Dec. 13, 2019 in Application No. 105101536.
TIPO; Office Action dated Nov. 6, 2019 in Application No. 105101537.
TIPO; Notice of Allowance dated May 7, 2019 in Application No. 105104453.
TIPO; Office Action dated Dec. 13, 2019 in Application No. 105111990.
TIPO; Office Action dated Jul. 5, 2019 in Application No. 105112363.
TIPO; Notice of Allowance dated Dec. 10, 2019 in Application No. 105112363.
TIPO; Office Action dated Oct. 1, 2019 in Application No. 105114105.
TIPO; Notice of Allowance dated Jan. 15, 2020 in Application No. 105114105.
TIPO; Office Action dated Sep. 9, 2019 in Application No. 105115513.
TIPO; Notice of Allowance dated Feb. 10, 2020 in Application No. 105115513.
TIPO; Office Action dated Oct. 3, 2019 in Application No. 105119533.
TIPO; Notice of Allowance dated Mar. 13, 2020 in Application No. 105119533.
TIPO; Office Action dated Jan. 20, 2020 in Application No. 105122394.
TIPO; Office Action dated Jan. 17, 2020 in Application No. 105122586.
TIPO; Office Action dated Oct. 28, 2019 in Application No. 105122715.
TIPO; Notice of Allowance dated Feb. 13, 2020 in Application No. 105122715.
TIPO; Notice of Allowance dated Dec. 5, 2017 in Application No. 105308015.
TIPO; Notice of Allowance dated Apr. 11, 2018 in Application No. 105308015D01.
TIPO; Office Action dated Nov. 6, 2017 in Application No. 106117181.
TIPO; Notice of Allowance dated Jun. 5, 2018 in Application No. 106117181.
TIPO; Office Action dated Sep. 28, 2018 in Application No. 106119537.
TIPO; Office Action dated Dec. 26, 2018 in Application No. 106127690.
TIPO; Office Action dated Aug. 31, 2018 in Application No. 106138119.
TIPO; Office Action dated Jun. 25, 2018 in Application No. 106138800.
TIPO; Office Action dated Jan. 7, 2019 in Application No. 106138800.
TIPO; Notice of Allowance dated Sep. 20, 2019 in Application No. 106138800.
TIPO; Office Action dated Oct. 3, 2018 in Application No. 106142731.
TIPO; Office Action dated Sep. 28, 2018 in Application No. 107112951.
TIPO; Office Action dated Aug. 27, 2019 in Application No. 107116804.
TIPO; Notice of Allowance dated Jan. 16, 2020 in Application No. 107116804.
TIPO; Office Action dated Nov. 20, 2018 in Application No. 107118271.
TIPO; Office Action dated Jun. 4, 2019 in Application No. 107123992.
TIPO; Office Action dated May 28, 2019 in Application No. 107125586.
TIPO; Office Action dated Jan. 17, 2020 in Application No. 107127688.
TIPO; Notice of Allowance dated Aug. 29, 2018 in Application No. 107300633.
TIPO; Notice of Allowance dated Feb. 21, 2019 in Application No. 107303723.
TIPO; Office Action dated May 31, 2019 in Application No. 108102146.
TIPO; Office Action dated Jun. 28, 2019 in Application No. 108102948.
TIPO; Office Action dated Dec. 24, 2019 in Application No. 108105002.
TIPO; Office Action dated Feb. 3, 2020 in Application No. 108114221.
TIPO; Office Action dated Nov. 13, 2019 in Application No. 108115406.
TIPO; Notice of Allowance dated Mar. 12, 2020 in Application No. 108129100.
USPTO; Notice of Allowance dated Jul. 26, 2005 in U.S. Appl. No. 10/033,058.
USPTO; Non-Final Office Action dated Aug. 25, 2005 in U.S. Appl. No. 10/191,635.

(56)

References Cited

OTHER PUBLICATIONS

- USPTO; Final Office Action dated Apr. 25, 2006 in U.S. Appl. No. 10/191,635.
- USPTO; Non-Final Office Action dated Nov. 20, 2006 in U.S. Appl. No. 10/191,635.
- USPTO; Notice of Allowance dated May 21, 2007 in U.S. Appl. No. 10/191,635.
- USPTO; Notice of Allowance dated Feb. 20, 2008 in U.S. Appl. No. 10/191,635.
- USPTO; Non-Final Office Action dated May 13, 2003 in U.S. Appl. No. 10/222,229.
- USPTO; Non-Final Office Action dated Oct. 22, 2003 in U.S. Appl. No. 10/222,229.
- USPTO; Final Office Action dated Mar. 22, 2004 in U.S. Appl. No. 10/222,229.
- USPTO; Advisory Action dated Oct. 7, 2004 in U.S. Appl. No. 10/222,229.
- USPTO; Non-Final Office Action dated Dec. 22, 2004 in U.S. Appl. No. 10/222,229.
- USPTO; Final Office Action dated Jun. 20, 2005 in U.S. Appl. No. 10/222,229.
- USPTO; Advisory Action dated Nov. 16, 2005 in U.S. Appl. No. 10/222,229.
- USPTO; Notice of Allowance dated Mar. 8, 2006 in U.S. Appl. No. 10/222,229.
- USPTO; Non-Final Office Action dated Jan. 26, 2005 in U.S. Appl. No. 10/838,510.
- USPTO; Notice of Allowance dated Jul. 12, 2005 in U.S. Appl. No. 10/838,510.
- USPTO; Office Action dated Feb. 15, 2011 in U.S. Appl. No. 12/118,596.
- USPTO; Notice of Allowance dated Aug. 4, 2011 in U.S. Appl. No. 12/118,596.
- USPTO; Non-Final Office Action dated Apr. 28, 2010 in U.S. Appl. No. 12/121,085.
- USPTO; Notice of Allowance dated Jul. 26, 2010 in U.S. Appl. No. 12/121,085.
- USPTO; Notice of Allowance dated Oct. 4, 2010 in U.S. Appl. No. 12/121,085.
- USPTO; Non-Final Office Action dated Sep. 13, 2010 in U.S. Appl. No. 12/140,809.
- USPTO; Final Office Action dated Dec. 28, 2010 in U.S. Appl. No. 12/140,809.
- USPTO; Notice of Allowance dated Mar. 17, 2011 in U.S. Appl. No. 12/140,809.
- USPTO; Non-Final Office Action dated Mar. 15, 2011 in U.S. Appl. No. 12/193,924.
- USPTO; Foma; Office Action dated Sep. 30, 2011 in U.S. Appl. No. 12/193,924.
- USPTO; Non-Final Office Action dated Oct. 24, 2012 in U.S. Appl. No. 12/193,924.
- USPTO; Final Office Action dated Apr. 17, 2013 in U.S. Appl. No. 12/193,924.
- USPTO; Advisory Action dated Jul. 9, 2013 in U.S. Appl. No. 12/193,924.
- USPTO; Non-Final Office Action dated Jul. 28, 2011 in U.S. Appl. No. 12/330,096.
- USPTO; Final Office Action dated Jan. 13, 2012 in U.S. Appl. No. 12/330,096.
- USPTO; Notice of Allowance dated Mar. 6, 2012 in U.S. Appl. No. 12/330,096.
- USPTO; Non-Final Office Action dated Mar. 20, 2012 in U.S. Appl. No. 12/330,096.
- USPTO; Notice of Allowance dated Jun. 7, 2012 in U.S. Appl. No. 12/330,096.
- USPTO; Non-Final Office Action dated Apr. 1, 2010 in U.S. Appl. No. 12/357,174.
- USPTO; Final Office Action dated Sep. 1, 2010 in U.S. Appl. No. 12/357,174.
- USPTO; Notice of Allowance dated Dec. 13, 2010 in U.S. Appl. No. 12/357,174.
- USPTO; Non-Final Office Action dated Dec. 29, 2010 in U.S. Appl. No. 12/362,023.
- USPTO; Non-Final Office Action dated Jul. 26, 2011 in U.S. Appl. No. 12/416,809.
- USPTO; Final Office Action dated Dec. 6, 2011 in U.S. Appl. No. 12/416,809.
- USPTO; Notice of Allowance dated Apr. 2, 2012 in U.S. Appl. No. 12/416,809.
- USPTO; Advisory Action dated Feb. 3, 2012 in U.S. Appl. No. 12/416,809.
- USPTO; Notice of Allowance dated Jun. 16, 2011 in U.S. Appl. No. 12/430,751.
- USPTO; Notice of Allowance dated Jul. 27, 2011 in U.S. Appl. No. 12/430,751.
- USPTO; Non-Final Office Action dated Aug. 3, 2011 in U.S. Appl. No. 12/436,300.
- USPTO; Final Office Action dated Jan. 23, 2012 in U.S. Appl. No. 12/436,300.
- USPTO; Advisory Action dated Mar. 6, 2012 in U.S. Appl. No. 12/436,300.
- USPTO; Non-Final Office Action dated May 22, 2012 in U.S. Appl. No. 12/436,300.
- USPTO; Notice of Allowance dated Nov. 28, 2012 in U.S. Appl. No. 12/436,300.
- USPTO; Non-Final Office Action dated Apr. 11, 2012 in U.S. Appl. No. 12/436,306.
- USPTO; Final Office Action dated Sep. 26, 2012 in U.S. Appl. No. 12/436,306.
- USPTO; Non-Final Office Action dated May 31, 2013 in U.S. Appl. No. 12/436,306.
- USPTO; Final Office Action dated Oct. 17, 2013 in U.S. Appl. No. 12/436,306.
- USPTO; Non-Final Office Action dated Feb. 4, 2014 in U.S. Appl. No. 12/436,306.
- USPTO; Final Office Action dated Jun. 23, 2014 in U.S. Appl. No. 12/436,306.
- USPTO; Advisory Action dated Oct. 1, 2014 in U.S. Appl. No. 12/436,306.
- USPTO; Non-Final Office Action dated Feb. 3, 2015 in U.S. Appl. No. 12/436,306.
- USPTO; Final Office Action dated May 13, 2015 in U.S. Appl. No. 12/436,306.
- USPTO; Non-Final Office Action dated Oct. 14, 2015 in U.S. Appl. No. 12/436,306.
- USPTO; Final Office Action dated Dec. 31, 2015 in U.S. Appl. No. 12/436,306.
- USPTO; Notice of Allowance dated Feb. 3, 2016 in U.S. Appl. No. 12/436,306.
- USPTO; Non-Final Office Action dated Aug. 3, 2011 in U.S. Appl. No. 12/436,315.
- USPTO; Notice of Allowance dated Nov. 17, 2011 in U.S. Appl. No. 12/436,315.
- USPTO; Notice of Allowance dated Oct. 1, 2010 in U.S. Appl. No. 12/467,017.
- USPTO; Non-Final Office Action dated Mar. 18, 2010 in U.S. Appl. No. 12/489,252.
- USPTO; Notice of Allowance dated Sep. 2, 2010 in U.S. Appl. No. 12/489,252.
- USPTO; Non-Final Office Action dated Dec. 15, 2010 in U.S. Appl. No. 12/553,759.
- USPTO; Final Office Action dated May 4, 2011 in U.S. Appl. No. 12/553,759.
- USPTO; Advisory Action dated Jul. 13, 2011 in U.S. Appl. No. 12/553,759.
- USPTO; Non-Final Office Action dated Sep. 6, 2011 in U.S. Appl. No. 12/553,759.
- USPTO; Notice of Allowance dated Jan. 27, 2012 in U.S. Appl. No. 12/553,759.
- USPTO; Non-Final Office Action dated Oct. 19, 2012 in U.S. Appl. No. 12/618,355.

(56)

References Cited

OTHER PUBLICATIONS

- USPTO; Final Office Action dated May 8, 2013 in U.S. Appl. No. 12/618,355.
- USPTO; Advisory Action dated Jul. 23, 2013 in U.S. Appl. No. 12/618,355.
- USPTO; Non-Final Office Action dated Apr. 8, 2015 in U.S. Appl. No. 12/618,355.
- USPTO; Final Office Action dated Oct. 22, 2015 in U.S. Appl. No. 12/618,355.
- USPTO; Advisory Action dated Mar. 4, 2016 in U.S. Appl. No. 12/618,355.
- USPTO; Non-Final Office Action dated Jun. 30, 2016 in U.S. Appl. No. 12/618,355.
- USPTO; Final Office Action dated Feb. 10, 2017 in U.S. Appl. No. 12/618,355.
- USPTO; Advisory Action dated May 16, 2017 in U.S. Appl. No. 12/618,355.
- USPTO; Non-Final Office Action dated Nov. 29, 2017 in U.S. Appl. No. 12/618,355.
- USPTO; Final Office Action dated Aug. 10, 2018 in U.S. Appl. No. 12/618,355.
- USPTO; Notice of Allowance dated Apr. 4, 2019 in U.S. Appl. No. 12/618,355.
- USPTO; Non-Final Office Action dated Feb. 16, 2012 in U.S. Appl. No. 12/618,419.
- USPTO; Final Office Action dated Jun. 22, 2012 in U.S. Appl. No. 12/618,419.
- USPTO; Non-Final Office Action dated Nov. 27, 2012 in U.S. Appl. No. 12/618,419.
- USPTO; Advisory Action dated Aug. 9, 2012 in U.S. Appl. No. 12/618,419.
- USPTO; Notice of Allowance dated Apr. 12, 2013 in U.S. Appl. No. 12/618,419.
- USPTO; Non-Final Office Action dated Jun. 12, 2013 in U.S. Appl. No. 12/618,419.
- USPTO; Notice of Allowance dated Oct. 9, 2013 in U.S. Appl. No. 12/618,419.
- USPTO; Non-Final Office Action dated Dec. 6, 2011 in U.S. Appl. No. 12/718,731.
- USPTO; Notice of Allowance dated Mar. 16, 2012 in U.S. Appl. No. 12/718,731.
- USPTO; Office Action dated Feb. 26, 2013 in U.S. Appl. No. 12/754,223.
- USPTO; Final Office Action dated Jun. 28, 2013 in U.S. Appl. No. 12/754,223.
- USPTO; Office Action dated Feb. 25, 2014 in U.S. Appl. No. 12/754,223.
- USPTO; Final Office Action dated Jul. 14, 2014 in U.S. Appl. No. 12/754,223.
- USPTO; Non-Final Office Action dated Mar. 25, 2015 in U.S. Appl. No. 12/754,223.
- USPTO; Final Office Action dated Aug. 12, 2015 in U.S. Appl. No. 12/754,223.
- USPTO; Notice of Allowance dated May 23, 2016 in U.S. Appl. No. 12/754,223.
- USPTO; Office Action dated Apr. 23, 2013 in U.S. Appl. No. 12/763,037.
- USPTO; Final Office Action dated Oct. 21, 2013 in U.S. Appl. No. 12/763,037.
- USPTO; Office Action dated Oct. 8, 2014 in U.S. Appl. No. 12/763,037.
- USPTO; Notice of Allowance dated Jan. 27, 2015 in U.S. Appl. No. 12/763,037.
- USPTO; Non-Final Office Action dated Jan. 24, 2011 in U.S. Appl. No. 12/778,808.
- USPTO; Notice of Allowance dated May 9, 2011 in U.S. Appl. No. 12/778,808.
- USPTO; Notice of Allowance dated Oct. 12, 2012 in U.S. Appl. No. 12/832,739.
- USPTO; Non-Final Office Action dated Oct. 16, 2012 in U.S. Appl. No. 12/847,848.
- USPTO; Final Office Action dated Apr. 22, 2013 in U.S. Appl. No. 12/847,848.
- USPTO; Advisory Action dated Jul. 1, 2013 in U.S. Appl. No. 12/847,848.
- USPTO; Notice of Allowance dated Jan. 16, 2014 in U.S. Appl. No. 12/847,848.
- USPTO; Office Action dated Dec. 6, 2012 in U.S. Appl. No. 12/854,818.
- USPTO; Final Office Action dated Mar. 13, 2013 in U.S. Appl. No. 12/854,818.
- USPTO; Office Action dated Aug. 30, 2013 in U.S. Appl. No. 12/854,818.
- USPTO; Final Office Action dated Mar. 26, 2014 in U.S. Appl. No. 12/854,818.
- USPTO; Office Action dated Jun. 3, 2014 in U.S. Appl. No. 12/854,818.
- USPTO; Non-Final Office Action dated Jul. 11, 2012 in U.S. Appl. No. 12/875,889.
- USPTO; Notice of Allowance dated Jan. 4, 2013 in U.S. Appl. No. 12/875,889.
- USPTO; Notice of Allowance dated Jan. 9, 2012 in U.S. Appl. No. 12/901,323.
- USPTO; Non-Final Office Action dated Nov. 20, 2013 in U.S. Appl. No. 12/910,607.
- USPTO; Final Office Action dated Apr. 28, 2014 in U.S. Appl. No. 12/910,607.
- USPTO; Advisory Action dated Jul. 9, 2014 in U.S. Appl. No. 12/910,607.
- USPTO; Notice of Allowance dated Aug. 15, 2014 in U.S. Appl. No. 12/910,607.
- USPTO; Non-Final Office Action dated Oct. 24, 2012 in U.S. Appl. No. 12/940,906.
- USPTO; Final Office Action dated Feb. 13, 2013 in U.S. Appl. No. 12/940,906.
- USPTO; Notice of Allowance dated Apr. 23, 2013 in U.S. Appl. No. 12/940,906.
- USPTO; Non-Final Office Action dated Dec. 7, 2012 in U.S. Appl. No. 12/953,870.
- USPTO; Final Office Action dated Apr. 22, 2013 in U.S. Appl. No. 12/953,870.
- USPTO; Advisory Action dated Jul. 8, 2013 in U.S. Appl. No. 12/953,870.
- USPTO; Non-Final Office Action dated Aug. 28, 2013 in U.S. Appl. No. 12/953,870.
- USPTO; Final Office Action dated Apr. 17, 2014 in U.S. Appl. No. 12/953,870.
- USPTO; Non-Final Office Action dated Sep. 19, 2012 in U.S. Appl. No. 13/016,735.
- USPTO; Final Office Action dated Feb. 11, 2013 in U.S. Appl. No. 13/016,735.
- USPTO; Notice of Allowance dated Apr. 24, 2013 in U.S. Appl. No. 13/016,735.
- USPTO; Non-Final Office Action dated Apr. 4, 2012 in U.S. Appl. No. 13/030,438.
- USPTO; Final Office Action dated Aug. 22, 2012 in U.S. Appl. No. 13/030,438.
- USPTO; Notice of Allowance dated Oct. 24, 2012 in U.S. Appl. No. 13/030,438.
- USPTO; Non-Final Office Action dated Dec. 3, 2012 in U.S. Appl. No. 13/040,013.
- USPTO; Notice of Allowance dated May 3, 2013 in U.S. Appl. No. 13/040,013.
- USPTO; Non-Final Office Action dated Feb. 15, 2012 in U.S. Appl. No. 13/085,531.
- USPTO; Notice of Allowance dated Jul. 12, 2012 in U.S. Appl. No. 13/085,531.
- USPTO; Notice of Allowance dated Sep. 13, 2012 in U.S. Appl. No. 13/085,698.
- USPTO; Non-Final Office Action dated Mar. 29, 2013 in U.S. Appl. No. 13/094,402.

(56)

References Cited

OTHER PUBLICATIONS

USPTO; Final Office Action dated Jul. 17, 2013 in U.S. Appl. No. 13/094,402.
USPTO; Notice of Allowance dated Sep. 30, 2013 in U.S. Appl. No. 13/094,402.
USPTO; Office Action dated Oct. 7, 2013 in U.S. Appl. No. 13/102,980.
USPTO; Final Office Action dated Mar. 25, 2014 in U.S. Appl. No. 13/102,980.
USPTO; Advisory Action dated Jun. 12, 2014 in U.S. Appl. No. 13/102,980.
USPTO; Notice of Allowance dated Jul. 3, 2014 in U.S. Appl. No. 13/102,980.
USPTO; Notice of Allowance dated Sep. 17, 2014 in U.S. Appl. No. 13/102,980.
USPTO; Non-Final Office Action dated Jul. 17, 2014 in U.S. Appl. No. 13/154,271.
USPTO; Final Office Action dated Jan. 2, 2015 in U.S. Appl. No. 13/154,271.
USPTO; Non-Final Office Action dated May 27, 2015 in U.S. Appl. No. 13/154,271.
USPTO; Final Office Action dated Nov. 23, 2015 in U.S. Appl. No. 13/154,271.
USPTO; Notice of Allowance dated Feb. 10, 2016 in U.S. Appl. No. 13/154,271.
USPTO; Non-Final Office Action dated Jun. 27, 2016 in U.S. Appl. No. 13/166,367.
USPTO; Final Office Action dated Dec. 30, 2016 in U.S. Appl. No. 13/166,367.
USPTO; Advisory Action dated Apr. 21, 2017 in U.S. Appl. No. 13/166,367.
USPTO; Notice of Allowance dated Jun. 28, 2017 in U.S. Appl. No. 13/166,367.
USPTO; Non-Final Office Action dated Oct. 27, 2014 in U.S. Appl. No. 13/169,951.
USPTO; Final Office Action dated May 26, 2015 in U.S. Appl. No. 13/169,951.
USPTO; Non-Final Office Action dated Sep. 1, 2015 in U.S. Appl. No. 13/169,951.
USPTO; Final Office Action dated Mar. 3, 2016 in U.S. Appl. No. 13/169,951.
USPTO; Non-Final Office Action dated Jun. 9, 2016 in U.S. Appl. No. 13/169,951.
USPTO; Final Office Action dated Dec. 9, 2016 in U.S. Appl. No. 13/169,951.
USPTO; Advisory Action dated May 13, 2016 in U.S. Appl. No. 13/169,951.
USPTO; Advisory Action dated Feb. 15, 2017 in U.S. Appl. No. 13/169,951.
USPTO; Non-Final Office Action dated Apr. 26, 2017 in U.S. Appl. No. 13/169,951.
USPTO; Final Office Action dated Nov. 2, 2017 in U.S. Appl. No. 13/169,951.
USPTO; Advisory Action dated Feb. 8, 2018 in U.S. Appl. No. 13/169,951.
USPTO; Non-Final Office Action dated Apr. 6, 2018 in U.S. Appl. No. 13/169,951.
USPTO; Final Office Action dated Nov. 2, 2018 in U.S. Appl. No. 13/169,951.
USPTO; Advisory Action dated Feb. 4, 2019 in U.S. Appl. No. 13/169,951.
USPTO; Notice of Allowance dated Apr. 4, 2019 in U.S. Appl. No. 13/169,951.
USPTO; Non-Final Office Action dated Jun. 24, 2014 in U.S. Appl. No. 13/181,407.
USPTO; Final Office Action dated Sep. 24, 2014 in U.S. Appl. No. 13/181,407.
USPTO; Advisory Action dated Dec. 17, 2014 in U.S. Appl. No. 13/181,407.

USPTO; Non-Final Office Action dated Jan. 2, 2015 in U.S. Appl. No. 13/181,407.
USPTO; Final Office Action dated Apr. 8, 2015 in U.S. Appl. No. 13/181,407.
USPTO; Non-Final Office Action dated Jan. 23, 2013 in U.S. Appl. No. 13/184,351.
USPTO; Final Office Action dated Jul. 29, 2013 in U.S. Appl. No. 13/184,351.
USPTO; Advisory Action dated Nov. 7, 2013 in U.S. Appl. No. 13/184,351.
USPTO; Non-Final Office Action dated Jul. 16, 2014 in U.S. Appl. No. 13/184,351.
USPTO; Final Office Action dated Feb. 17, 2015 in U.S. Appl. No. 13/184,351.
USPTO; Advisory Action dated May 18, 2015 in U.S. Appl. No. 13/184,351.
USPTO; Non-Final Office Action dated Aug. 10, 2015 in U.S. Appl. No. 13/184,351.
USPTO; Final Office Action dated Feb. 12, 2016 in U.S. Appl. No. 13/184,351.
USPTO; Non-Final Office Action dated Dec. 15, 2016 in U.S. Appl. No. 13/184,351.
USPTO; Final Office Action dated Jun. 15, 2017 in U.S. Appl. No. 13/184,351.
USPTO; Advisory Action dated Oct. 4, 2017 in U.S. Appl. No. 13/184,351.
USPTO; Non-Final Office Action dated Jul. 26, 2018 in U.S. Appl. No. 13/184,351.
USPTO; Final Office Action dated Dec. 28, 2018 in U.S. Appl. No. 13/184,351.
USPTO; Non-Final Office Action dated Aug. 19, 2019 in U.S. Appl. No. 13/184,351.
USPTO; Non-Final Office Action dated Sep. 17, 2014 in U.S. Appl. No. 13/187,300.
USPTO; Final Office Action dated Apr. 15, 2015 in U.S. Appl. No. 13/187,300.
USPTO; Non-Final Office Action dated Apr. 7, 2016 in U.S. Appl. No. 13/187,300.
USPTO; Final Office Action dated Sep. 23, 2016 in U.S. Appl. No. 13/187,300.
USPTO; Non-Final Office Action dated Jan. 30, 2017 in U.S. Appl. No. 13/187,300.
USPTO; Final Office Action dated Aug. 9, 2017 in U.S. Appl. No. 13/187,300.
USPTO; Non-Final Office Action dated Oct. 1, 2012 in U.S. Appl. No. 13/191,762.
USPTO; Final Office Action dated Apr. 10, 2013 in U.S. Appl. No. 13/191,762.
USPTO; Notice of Allowance dated Aug. 15, 2013 in U.S. Appl. No. 13/191,762.
USPTO; Non-Final Office Action dated Oct. 22, 2012 in U.S. Appl. No. 13/238,960.
USPTO; Final Office Action dated May 3, 2013 in U.S. Appl. No. 13/238,960.
USPTO; Non-Final Office Action dated Apr. 26, 2013 in U.S. Appl. No. 13/250,721.
USPTO; Notice of Allowance dated Sep. 11, 2013 in U.S. Appl. No. 13/250,721.
USPTO; Non-Final Office Action dated Jul. 2, 2014 in U.S. Appl. No. 13/283,408.
USPTO; Final Office Action dated Jan. 29, 2015 in U.S. Appl. No. 13/283,408.
USPTO; Non-Final Office Action dated Jun. 17, 2015 in U.S. Appl. No. 13/283,408.
USPTO; Final Office Action dated Dec. 18, 2015 in U.S. Appl. No. 13/283,408.
USPTO; Advisory Action dated Mar. 28, 2016 in U.S. Appl. No. 13/283,408.
USPTO; Notice of Allowance dated Mar. 28, 2016 in U.S. Appl. No. 13/283,408.
USPTO; Non-Final Office Action dated Jul. 30, 2014 in U.S. Appl. No. 13/284,642.

(56)

References Cited

OTHER PUBLICATIONS

- USPTO; Notice of Allowance dated Feb. 11, 2015 in U.S. Appl. No. 13/284,642.
- USPTO; Non-Final Office Action dated Jan. 28, 2014 in U.S. Appl. No. 13/312,591.
- USPTO; Final Office Action dated May 14, 2014 in U.S. Appl. No. 13/312,591.
- USPTO; Advisory Action dated Aug. 26, 2014 in U.S. Appl. No. 13/312,591.
- USPTO; Non-Final Office Action dated Nov. 26, 2014 in U.S. Appl. No. 13/312,591.
- USPTO; Final Office Action dated Mar. 20, 2015 in U.S. Appl. No. 13/312,591.
- USPTO; Notice of Allowance dated May 14, 2015 in U.S. Appl. No. 13/312,591.
- USPTO; Notice of Allowance dated Jun. 11, 2015 in U.S. Appl. No. 13/312,591.
- USPTO; Non-Final Office Action dated Apr. 9, 2014 in U.S. Appl. No. 13/333,420.
- USPTO; Notice of Allowance dated Sep. 15, 2014 in U.S. Appl. No. 13/333,420.
- USPTO; Office Action dated Feb. 11, 2013 in U.S. Appl. No. 13/339,609.
- USPTO; Final Office Action dated May 17, 2013 in U.S. Appl. No. 13/339,609.
- USPTO; Office Action dated Aug. 29, 2013 in U.S. Appl. No. 13/339,609.
- USPTO; Final Office Action dated Dec. 18, 2013 in U.S. Appl. No. 13/339,609.
- USPTO; Notice of Allowance dated Apr. 7, 2014 in U.S. Appl. No. 13/339,609.
- USPTO; Non-Final Office Action dated Oct. 10, 2012 in U.S. Appl. No. 13/406,791.
- USPTO; Final Office Action dated Jan. 31, 2013 in U.S. Appl. No. 13/406,791.
- USPTO; Advisory Action dated Mar. 27, 2013 in U.S. Appl. No. 13/406,791.
- USPTO; Non-Final Office Action dated Apr. 25, 2013 in U.S. Appl. No. 13/406,791.
- USPTO; Final Office Action dated Aug. 23, 2013 in U.S. Appl. No. 13/406,791.
- USPTO; Advisory Action dated Oct. 29, 2013 in U.S. Appl. No. 13/406,791.
- USPTO; Non-Final Office Action dated Dec. 4, 2013 in U.S. Appl. No. 13/406,791.
- USPTO; Final Office Action dated Apr. 21, 2014 in U.S. Appl. No. 13/406,791.
- USPTO; Non-Final Office Action dated Jan. 14, 2013 in U.S. Appl. No. 13/410,970.
- USPTO; Notice of Allowance dated Feb. 14, 2013 in U.S. Appl. No. 13/410,970.
- USPTO; Non-Final Office Action dated Feb. 13, 2014 in U.S. Appl. No. 13/411,271.
- USPTO; Non-Final Office Action dated Jul. 31, 2014 in U.S. Appl. No. 13/411,271.
- USPTO; Advisory Action dated Apr. 22, 2015 in U.S. Appl. No. 13/411,271.
- USPTO; Final Office Action dated Jan. 16, 2015 in U.S. Appl. No. 13/411,271.
- USPTO; Notice of Allowance dated Oct. 6, 2015 in U.S. Appl. No. 13/411,271.
- USPTO; Office Action dated Feb. 4, 2014 in U.S. Appl. No. 13/439,528.
- USPTO; Final Office Action dated Jul. 8, 2014 in U.S. Appl. No. 13/439,528.
- USPTO; Notice of Allowance dated Oct. 21, 2014 in U.S. Appl. No. 13/439,528.
- USPTO; Non-Final Office Action dated Apr. 11, 2013 in U.S. Appl. No. 13/450,368.
- USPTO; Notice of Allowance dated Jul. 17, 2013 in U.S. Appl. No. 13/450,368.
- USPTO; Non-Final Office Action dated May 23, 2013 in U.S. Appl. No. 13/465,340.
- USPTO; Final Office Action dated Oct. 30, 2013 in U.S. Appl. No. 13/465,340.
- USPTO; Notice of Allowance dated Feb. 12, 2014 in U.S. Appl. No. 13/465,340.
- USPTO; Non-Final Office Action dated Oct. 17, 2013 in U.S. Appl. No. 13/493,897.
- USPTO; Notice of Allowance dated Mar. 20, 2014 in U.S. Appl. No. 13/493,897.
- USPTO; Non-Final Office Action dated Dec. 20, 2013 in U.S. Appl. No. 13/535,214.
- USPTO; Final Office Action dated Jun. 18, 2014 in U.S. Appl. No. 13/535,214.
- USPTO; Notice of Allowance dated Oct. 23, 2014 in U.S. Appl. No. 13/535,214.
- USPTO; Non-Final Office Action dated Sep. 11, 2013 in U.S. Appl. No. 13/550,419.
- USPTO; Final Office Action dated Jan. 27, 2014 in U.S. Appl. No. 13/550,419.
- USPTO; Advisory Action dated Mar. 31, 2014 in U.S. Appl. No. 13/550,419.
- USPTO; Notice of Allowance dated May 29, 2014 in U.S. Appl. No. 13/550,419.
- USPTO; Non-Final Office Action dated Aug. 8, 2014 in U.S. Appl. No. 13/563,066.
- USPTO; Final Office Action dated Feb. 12, 2015 in U.S. Appl. No. 13/563,066.
- USPTO; Advisory Action dated Apr. 16, 2015 in U.S. Appl. No. 13/563,066.
- USPTO; Notice of Allowance dated Jun. 12, 2015 in U.S. Appl. No. 13/563,066.
- USPTO; Notice of Allowance dated Jul. 16, 2015 in U.S. Appl. No. 13/563,066.
- USPTO; Non-Final Office Action dated May 28, 2013 in U.S. Appl. No. 13/563,274.
- USPTO; Notice of Allowance dated Sep. 27, 2013 in U.S. Appl. No. 13/563,274.
- USPTO; Non-Final Office Action dated Nov. 7, 2013 in U.S. Appl. No. 13/565,564.
- USPTO; Final Office Action dated Feb. 28, 2014 in U.S. Appl. No. 13/565,564.
- USPTO; Advisory Action dated May 5, 2014 in U.S. Appl. No. 13/565,564.
- USPTO; Non-Final Office Action dated Jul. 2, 2014 in U.S. Appl. No. 13/565,564.
- USPTO; Notice of Allowance dated Nov. 3, 2014 in U.S. Appl. No. 13/565,564.
- USPTO; Notice of Allowance dated Sep. 13, 2013 in U.S. Appl. No. 13/566,069.
- USPTO; Non-Final Office Action dated Aug. 30, 2013 in U.S. Appl. No. 13/570,067.
- USPTO; Notice of Allowance dated Jan. 6, 2014 in U.S. Appl. No. 13/570,067.
- USPTO; Non-Final Office Action dated Oct. 15, 2014 in U.S. Appl. No. 13/597,043.
- USPTO; Final Office Action dated Mar. 13, 2015 in U.S. Appl. No. 13/597,043.
- USPTO; Notice of Allowance dated Aug. 28, 2015 in U.S. Appl. No. 13/597,043.
- USPTO; Non-Final Office Action dated Feb. 12, 2015 in U.S. Appl. No. 13/597,108.
- USPTO; Final Office Action dated Jun. 1, 2015 in U.S. Appl. No. 13/597,108.
- USPTO; Advisory Action dated Sep. 2, 2015 in U.S. Appl. No. 13/597,108.
- USPTO; Non-Final Office Action dated Dec. 8, 2015 in U.S. Appl. No. 13/597,108.
- USPTO; Final Office Action dated Jun. 2, 2016 in U.S. Appl. No. 13/597,108.

(56)

References Cited

OTHER PUBLICATIONS

- USPTO; Non-Final Office Action dated Sep. 15, 2016 in U.S. Appl. No. 13/597,108.
- USPTO; Notice of Allowance dated Mar. 7, 2017 in U.S. Appl. No. 13/597,108.
- USPTO; Notice of Allowance dated Mar. 27, 2014 in U.S. Appl. No. 13/604,498.
- USPTO; Non-Final Office Action dated Nov. 15, 2013 in U.S. Appl. No. 13/612,538.
- USPTO; Non-Final Office Action dated Jul. 10, 2014 in U.S. Appl. No. 13/612,538.
- USPTO; Notice of Allowance dated Feb. 25, 2015 in U.S. Appl. No. 13/612,538.
- USPTO; Non-Final Office Action dated Apr. 15, 2015 in U.S. Appl. No. 13/646,403.
- USPTO; Final Office Action dated Oct. 15, 2015 in U.S. Appl. No. 13/646,403.
- USPTO; Notice of Allowance dated Feb. 2, 2016 in U.S. Appl. No. 13/646,403.
- USPTO; Non-Final Office Action dated May 15, 2014 in U.S. Appl. No. 13/646,471.
- USPTO; Final Office Action dated Aug. 18, 2014 in U.S. Appl. No. 13/646,471.
- USPTO; Advisory Action dated Nov. 14, 2014 in U.S. Appl. No. 13/646,471.
- USPTO; Non-Final Office Action dated Dec. 16, 2014 in U.S. Appl. No. 13/646,471.
- USPTO; Final Office Action dated Apr. 21, 2015 in U.S. Appl. No. 13/646,471.
- USPTO; Non-Final Office Action dated Aug. 19, 2015 in U.S. Appl. No. 13/646,471.
- USPTO; Final Office Action dated Jan. 22, 2016 in U.S. Appl. No. 13/646,471.
- USPTO; Advisory Action dated Apr. 15, 2016 in U.S. Appl. No. 13/646,471.
- USPTO; Non-Final Office Action dated Jun. 2, 2016 in U.S. Appl. No. 13/646,471.
- USPTO; Final Office Action dated Oct. 20, 2016 in U.S. Appl. No. 13/646,471.
- USPTO; Non-Final Office Action dated May 28, 2015 in U.S. Appl. No. 13/651,144.
- USPTO; Final Office Action dated Dec. 14, 2017 in U.S. Appl. No. 13/651,144.
- USPTO; Final Office Action dated Nov. 19, 2015 in U.S. Appl. No. 13/651,144.
- USPTO; Advisory Action dated Feb. 12, 2016 in U.S. Appl. No. 13/651,144.
- USPTO; Non-Final Office Action dated May 10, 2016 in U.S. Appl. No. 13/651,144.
- USPTO; Final Office Action dated Sep. 20, 2016 in U.S. Appl. No. 13/651,144.
- USPTO; Advisory Action dated Dec. 29, 2016 in U.S. Appl. No. 13/651,144.
- USPTO; Non-Final Office Action dated May 17, 2017 in U.S. Appl. No. 13/651,144.
- USPTO; Non-Final Office Action dated Dec. 14, 2017 in U.S. Appl. No. 13/651,144.
- USPTO; Advisory Action dated Apr. 19, 2018 in U.S. Appl. No. 13/651,144.
- USPTO; Non-Final Office Action dated Sep. 20, 2018 in U.S. Appl. No. 13/651,144.
- USPTO; Final Office Action dated Mar. 15, 2019 in U.S. Appl. No. 13/651,144.
- USPTO; Non-Final Office Action dated Sep. 18, 2019 in U.S. Appl. No. 13/651,144.
- USPTO; Notice of Allowance dated Feb. 10, 2020 in U.S. Appl. No. 13/651,144.
- USPTO; Advisory Action dated Jun. 26, 2015 in U.S. Appl. No. 13/791,246.
- USPTO; Non-Final Office Action dated Jun. 18, 2015 in U.S. Appl. No. 13/665,366.
- USPTO; Final Office Action dated Mar. 1, 2016 in U.S. Appl. No. 13/665,366.
- USPTO; Advisory Action dated May 13, 2016 in U.S. Appl. No. 13/665,366.
- USPTO; Non-Final Office Action dated Jun. 17, 2016 in U.S. Appl. No. 13/665,366.
- USPTO; Final Office Action dated May 3, 2017 in U.S. Appl. No. 13/665,366.
- USPTO; Non-Final Office Action dated Apr. 3, 2015 in U.S. Appl. No. 13/677,133.
- USPTO; Notice of Allowance dated Aug. 4, 2015 in U.S. Appl. No. 13/677,133.
- USPTO; Notice of Allowance dated Aug. 24, 2015 in U.S. Appl. No. 13/677,133.
- USPTO; Office Action dated Jun. 2, 2014 in U.S. Appl. No. 13/677,151.
- USPTO; Final Office Action dated Nov. 14, 2014 in U.S. Appl. No. 13/677,151.
- USPTO; Notice of Allowance dated Feb. 26, 2015 in U.S. Appl. No. 13/677,151.
- USPTO; Notice of Allowance dated Mar. 17, 2015 in U.S. Appl. No. 13/677,151.
- USPTO; Non-Final Office Action dated Aug. 20, 2013 in U.S. Appl. No. 13/679,502.
- USPTO; Final Office Action dated Feb. 25, 2014 in U.S. Appl. No. 13/679,502.
- USPTO; Notice of Allowance dated May 2, 2014 in U.S. Appl. No. 13/679,502.
- USPTO; Non-Final Office Action dated Jul. 21, 2015 in U.S. Appl. No. 13/727,324.
- USPTO; Final Office Action dated Jan. 22, 2016 in U.S. Appl. No. 13/727,324.
- USPTO; Advisory Action dated Apr. 6, 2016 in U.S. Appl. No. 13/727,324.
- USPTO; Non-Final Office Action dated May 25, 2016 in U.S. Appl. No. 13/727,324.
- USPTO; Final Office Action dated Dec. 1, 2016 in U.S. Appl. No. 13/727,324.
- USPTO; Notice of Allowance dated Mar. 1, 2017 in U.S. Appl. No. 13/727,324.
- USPTO; Non-Final Office Action dated Oct. 24, 2013 in U.S. Appl. No. 13/749,878.
- USPTO; Non-Final Office Action dated Jun. 18, 2014 in U.S. Appl. No. 13/749,878.
- USPTO; Final Office Action dated Dec. 10, 2014 in U.S. Appl. No. 13/749,878.
- USPTO; Notice of Allowance Mar. 13, 2015 dated in U.S. Appl. No. 13/749,878.
- USPTO; Non-Final Office Action dated Sep. 16, 2013 in U.S. Appl. No. 13/760,160.
- USPTO; Final Office Action dated Dec. 27, 2013 in U.S. Appl. No. 13/760,160.
- USPTO; Non-Final Office Action dated Jun. 4, 2014 in U.S. Appl. No. 13/760,160.
- USPTO; Final Office Action dated Sep. 25, 2014 in U.S. Appl. No. 13/760,160.
- USPTO; Final Office Action dated Jan. 28, 2015 in U.S. Appl. No. 13/760,160.
- USPTO; Final Office Action dated May 12, 2015 in U.S. Appl. No. 13/760,160.
- USPTO; Notice of Allowance dated Oct. 21, 2015 in U.S. Appl. No. 13/760,160.
- USPTO; Notice of Allowance dated Jan. 20, 2016 in U.S. Appl. No. 13/760,160.
- USPTO; Office Action dated Apr. 23, 2014 in U.S. Appl. No. 13/784,362.
- USPTO; Notice of Allowance dated Aug. 13, 2014 in U.S. Appl. No. 13/784,362.
- USPTO; Non-Final Office Action dated Dec. 19, 2013 in U.S. Appl. No. 13/784,388.

(56)

References Cited

OTHER PUBLICATIONS

- USPTO; Notice of Allowance dated Jun. 4, 2014 in U.S. Appl. No. 13/784,388.
- USPTO; Non-Final Office Action dated Sep. 19, 2014 in U.S. Appl. No. 13/791,246.
- USPTO; Final Office Action dated Mar. 25, 2015 in U.S. Appl. No. 13/791,246.
- USPTO; Non-Final Office Action dated Oct. 26, 2015 in U.S. Appl. No. 13/791,246.
- USPTO; Final Office Action dated Apr. 20, 2016 in U.S. Appl. No. 13/791,246.
- USPTO; Advisory Action dated Jul. 13, 2016 in U.S. Appl. No. 13/791,246.
- USPTO; Non-Final Office Action dated Aug. 11, 2016 in U.S. Appl. No. 13/791,246.
- USPTO; Notice of Allowance dated Oct. 19, 2016 in U.S. Appl. No. 13/791,246.
- USPTO; Notice of Allowance dated Nov. 25, 2016 in U.S. Appl. No. 13/791,246.
- USPTO; Non-Final Office Action dated Nov. 6, 2015 in U.S. Appl. No. 13/791,339.
- USPTO; Final Office Action dated Apr. 12, 2016 in U.S. Appl. No. 13/791,339.
- USPTO; Advisory Action dated Jul. 14, 2016 in U.S. Appl. No. 13/791,339.
- USPTO; Notice of Allowance dated Aug. 24, 2016 in U.S. Appl. No. 13/791,339.
- USPTO; Non-Final Office Action dated Mar. 21, 2014 in U.S. Appl. No. 13/799,708.
- USPTO; Notice of Allowance dated Oct. 31, 2014 in U.S. Appl. No. 13/799,708.
- USPTO; Non-Final Office Action dated Oct. 9, 2014 in U.S. Appl. No. 13/874,708.
- USPTO; Notice of Allowance dated Mar. 10, 2015 in U.S. Appl. No. 13/874,708.
- USPTO; Notice of Allowance dated Apr. 10, 2014 in U.S. Appl. No. 13/901,341.
- USPTO; Notice of Allowance dated Jun. 6, 2014 in U.S. Appl. No. 13/901,341.
- USPTO; Non-Final Office Action dated Jan. 2, 2015 in U.S. Appl. No. 13/901,372.
- USPTO; Final Office Action dated Apr. 16, 2015 in U.S. Appl. No. 13/901,372.
- USPTO; Notice of Allowance dated Aug. 5, 2015 in U.S. Appl. No. 13/901,372.
- USPTO; Advisory Action dated Jun. 29, 2015 in U.S. Appl. No. 13/901,372.
- USPTO; Non-Final Office Action dated Jul. 8, 2015 in U.S. Appl. No. 13/901,400.
- USPTO; Final Office Action dated Jan. 14, 2016 in U.S. Appl. No. 13/901,400.
- USPTO; Notice of Allowance dated Apr. 12, 2016 in U.S. Appl. No. 13/901,400.
- USPTO; Non-Final Office Action dated Apr. 24, 2014 in U.S. Appl. No. 13/912,666.
- USPTO; Final Office Action dated Sep. 25, 2014 in U.S. Appl. No. 13/912,666.
- USPTO; Advisory Action dated Dec. 11, 2014 in U.S. Appl. No. 13/912,666.
- USPTO; Non-Final Office Action dated Jan. 26, 2015 in U.S. Appl. No. 13/912,666.
- USPTO; Notice of Allowance dated Jun. 25, 2015 in U.S. Appl. No. 13/912,666.
- USPTO; Non-Final Office Action dated Dec. 16, 2014 in U.S. Appl. No. 13/915,732.
- USPTO; Final Office Action dated Apr. 10, 2015 in U.S. Appl. No. 13/915,732.
- USPTO; Notice of Allowance dated Jun. 19, 2015 in U.S. Appl. No. 13/915,732.
- USPTO; Notice of Allowance dated Mar. 17, 2015 in U.S. Appl. No. 13/923,197.
- USPTO; Non-Final Office Action dated Sep. 12, 2014 in U.S. Appl. No. 13/941,134.
- USPTO; Notice of Allowance dated Jan. 20, 2015 in U.S. Appl. No. 13/941,134.
- USPTO; Non-Final Office Action dated Jul. 30, 2015 in U.S. Appl. No. 13/941,216.
- USPTO; Final Office Action dated Mar. 1, 2016 in U.S. Appl. No. 13/941,216.
- USPTO; Non-Final Office Action dated Jun. 15, 2016 in U.S. Appl. No. 13/941,216.
- USPTO; Notice of Allowance dated Sep. 13, 2016 in U.S. Appl. No. 13/941,216.
- USPTO; Notice of Allowance dated Nov. 14, 2016 in U.S. Appl. No. 13/941,216.
- USPTO; Non-Final Office Action dated Jan. 14, 2014 in U.S. Appl. No. 13/941,226.
- USPTO; Non-Final Office Action dated Jul. 8, 2014 in U.S. Appl. No. 13/941,226.
- USPTO; Non-Final Office Action dated Feb. 3, 2015 in U.S. Appl. No. 13/941,226.
- USPTO; Final Office Action dated Feb. 12, 2016 in U.S. Appl. No. 13/941,226.
- USPTO; Advisory Action dated Jul. 29, 2016 in U.S. Appl. No. 13/941,226.
- USPTO; Non-Final Office Action dated Aug. 8, 2017 in U.S. Appl. No. 13/941,226.
- USPTO; Notice of Allowance dated Aug. 13, 2018 in U.S. Appl. No. 13/941,226.
- USPTO; Notice of Allowance dated Oct. 3, 2018 in U.S. Appl. No. 13/941,226.
- USPTO; Non-Final Office Action dated Oct. 30, 2014 in U.S. Appl. No. 13/948,055.
- USPTO; Notice of Allowance dated Feb. 27, 2015 in U.S. Appl. No. 13/948,055.
- USPTO; Notice of Allowance dated Mar. 31, 2015 in U.S. Appl. No. 13/948,055.
- USPTO; Non-Final Office Action dated Jun. 29, 2015 in U.S. Appl. No. 13/966,782.
- USPTO; Final Office Action dated Jan. 4, 2016 in U.S. Appl. No. 13/966,782.
- USPTO; Notice of Allowance dated Mar. 21, 2016 in U.S. Appl. No. 13/966,782.
- USPTO; Notice of Allowance dated Oct. 7, 2015 in U.S. Appl. No. 13/973,777.
- USPTO; Non-Final Office Action dated Feb. 20, 2015 in U.S. Appl. No. 14/018,231.
- USPTO; Notice of Allowance dated Jul. 20, 2015 in U.S. Appl. No. 14/018,231.
- USPTO; Non-Final Office Action dated Apr. 7, 2015 in U.S. Appl. No. 14/018,345.
- USPTO; Final Office Action dated Sep. 14, 2015 in U.S. Appl. No. 14/018,345.
- USPTO; Notice of Allowance dated Jan. 14, 2016 in U.S. Appl. No. 14/018,345.
- USPTO; Notice of Allowance dated Mar. 17, 2016 in U.S. Appl. No. 14/018,345.
- USPTO; Non-Final Office Action dated Mar. 26, 2015 in U.S. Appl. No. 14/031,982.
- USPTO; Final Office Action dated Aug. 28, 2015 in U.S. Appl. No. 14/031,982.
- USPTO; Notice of Allowance dated Nov. 17, 2015 in U.S. Appl. No. 14/031,982.
- USPTO; Non-Final Office Action dated Jan. 2, 2015 in U.S. Appl. No. 14/040,196.
- USPTO; Non-Final Office Action dated Apr. 28, 2015 in U.S. Appl. No. 14/040,196.
- USPTO; Notice of Allowance dated Sep. 11, 2015 in U.S. Appl. No. 14/040,196.
- USPTO; Non-Final Action dated Dec. 3, 2015 in U.S. Appl. No. 14/050,150.

(56)

References Cited

OTHER PUBLICATIONS

- USPTO; Final Office Action dated Jun. 15, 2016 in U.S. Appl. No. 14/050,150.
- USPTO; Final Office Action dated Jul. 8, 2016 in U.S. Appl. No. 14/050,150.
- USPTO; Notice of Allowance dated Oct. 20, 2016 in U.S. Appl. No. 14/050,150.
- USPTO; Non-Final Office Action dated Dec. 15, 2014 in U.S. Appl. No. 14/065,114.
- USPTO; Final Office Action dated Jun. 19, 2015 in U.S. Appl. No. 14/065,114.
- USPTO; Advisory Action dated Aug. 24, 2015 in U.S. Appl. No. 14/065,114.
- USPTO; Non-Final Office Action dated Oct. 7, 2015 in U.S. Appl. No. 14/065,114.
- USPTO; Notice of Allowance dated Feb. 22, 2016 in U.S. Appl. No. 14/065,114.
- USPTO; Non-Final Office Action dated Nov. 14, 2014 in U.S. Appl. No. 14/069,244.
- USPTO; Notice of Allowance dated Mar. 25, 2015 in U.S. Appl. No. 14/069,244.
- USPTO; Non-Final Office Action dated Mar. 19, 2015 in U.S. Appl. No. 14/079,302.
- USPTO; Final Office Action dated Sep. 1, 2015 in U.S. Appl. No. 14/079,302.
- USPTO; Non-Final Office Action dated Dec. 23, 2015 in U.S. Appl. No. 14/079,302.
- USPTO; Non-Final Office Action dated Apr. 27, 2016 in U.S. Appl. No. 14/079,302.
- USPTO; Final Office Action dated Aug. 22, 2016 in U.S. Appl. No. 14/079,302.
- USPTO; Notice of Allowance dated Dec. 14, 2016 in U.S. Appl. No. 14/079,302.
- USPTO; Non-Final Office Action dated Sep. 9, 2015 in U.S. Appl. No. 14/090,750.
- USPTO; Final Office Action dated Feb. 11, 2016 in U.S. Appl. No. 14/090,750.
- USPTO; Advisory Action dated May 5, 2016 in U.S. Appl. No. 14/090,750.
- USPTO; Non-Final Office Action dated Jun. 14, 2016 in U.S. Appl. No. 14/090,750.
- USPTO; Advisory Action dated Dec. 21, 2016 in U.S. Appl. No. 14/090,750.
- USPTO; Advisory Action dated Jan. 30, 2018 in U.S. Appl. No. 14/090,750.
- USPTO; Final Office Action dated Sep. 28, 2016 in U.S. Appl. No. 14/090,750.
- USPTO; Non-Final Office Action dated Jun. 23, 2017 in U.S. Appl. No. 14/090,750.
- USPTO; Final Office Action dated Nov. 17, 2017 in U.S. Appl. No. 14/090,750.
- USPTO; Non-Final Office Action dated Mar. 12, 2018 in U.S. Appl. No. 14/090,750.
- USPTO; Notice of Allowance dated Aug. 29, 2018 in U.S. Appl. No. 14/090,750.
- USPTO; Non-Final Office Action dated Mar. 19, 2015 in U.S. Appl. No. 14/166,462.
- USPTO; Notice of Allowance dated Sep. 3, 2015 in U.S. Appl. No. 14/166,462.
- USPTO; Non-Final Office Action dated Nov. 17, 2015 in U.S. Appl. No. 14/172,220.
- USPTO; Notice of Allowance dated Apr. 22, 2016 in U.S. Appl. No. 14/172,220.
- USPTO; Office Action dated May 29, 2014 in U.S. Appl. No. 14/183,187.
- USPTO; Final Office Action dated Nov. 7, 2014 in U.S. Appl. No. 14/183,187.
- USPTO; Advisory Action dated Feb. 20, 2015 in U.S. Appl. No. 14/183,187.
- USPTO; Non-Final Office Action dated Mar. 16, 2015 in U.S. Appl. No. 14/183,187.
- USPTO; Final Office Action dated Jul. 10, 2015 in U.S. Appl. No. 14/183,187.
- USPTO; Notice of Allowance dated Aug. 31, 2015 in U.S. Appl. No. 14/183,187.
- USPTO; Non-Final Office Action dated Jan. 11, 2016 in U.S. Appl. No. 14/188,760.
- USPTO; Final Office Action dated Aug. 25, 2016 in U.S. Appl. No. 14/188,760.
- USPTO; Advisory Action dated Jan. 12, 2017 in U.S. Appl. No. 14/188,760.
- USPTO; Non-Final Office Action dated Mar. 23, 2017 in U.S. Appl. No. 14/188,760.
- USPTO; Final Office Action dated Oct. 5, 2017 in U.S. Appl. No. 14/188,760.
- USPTO; Advisory Action dated Jan. 3, 2018 in U.S. Appl. No. 14/188,760.
- USPTO; Non-Final Office Action dated Apr. 18, 2018 in U.S. Appl. No. 14/188,760.
- USPTO; Final Office Action dated Jan. 25, 2019 in U.S. Appl. No. 14/188,760.
- USPTO; Non-Final Office Action dated Aug. 8, 2019 in U.S. Appl. No. 14/188,760.
- USPTO; Notice of Allowance dated Feb. 10, 2020 in U.S. Appl. No. 14/188,760.
- USPTO; Non-Final Office Action dated Oct. 8, 2015 in U.S. Appl. No. 14/218,374.
- USPTO; Final Office Action dated Feb. 23, 2016 in U.S. Appl. No. 14/218,374.
- USPTO; Advisory Action dated Apr. 29, 2016 in U.S. Appl. No. 14/218,374.
- USPTO; Notice of Allowance dated Aug. 5, 2016 in U.S. Appl. No. 14/218,374.
- USPTO; Non-Final Office Action dated Jul. 15, 2016 in U.S. Appl. No. 14/218,690.
- USPTO; Final Office Action dated Nov. 14, 2016 in U.S. Appl. No. 14/218,690.
- USPTO; Non-Final Office Action dated Apr. 6, 2017 in U.S. Appl. No. 14/218,690.
- USPTO; Final Office Action dated Jul. 20, 2017 in U.S. Appl. No. 14/218,690.
- USPTO; Non-Final Office Action dated Jan. 11, 2018 in U.S. Appl. No. 14/218,690.
- USPTO; Final Office Action dated May 24, 2018 in U.S. Appl. No. 14/218,690.
- USPTO; Notice of Allowance dated Sep. 24, 2018 in U.S. Appl. No. 14/218,690.
- USPTO; Non-Final Office Action dated Sep. 22, 2015 in U.S. Appl. No. 14/219,839.
- USPTO; Final Office Action dated Mar. 25, 2016 in U.S. Appl. No. 14/219,839.
- USPTO; Non-Final Office Action dated Dec. 22, 2016 in U.S. Appl. No. 14/219,839.
- USPTO; Advisory Action dated Jun. 30, 2016 in U.S. Appl. No. 14/219,839.
- USPTO; Final Office Action dated Jul. 6, 2017 in U.S. Appl. No. 14/219,839.
- USPTO; Non-Final Office Action dated Mar. 27, 2018 in U.S. Appl. No. 14/219,839.
- USPTO; Final Office Action dated Nov. 1, 2018 in U.S. Appl. No. 14/219,839.
- USPTO; Advisory Action dated Jan. 22, 2019 in U.S. Appl. No. 14/219,839.
- USPTO; Non-Final Office Action dated Jul. 15, 2019 in U.S. Appl. No. 14/219,839.
- USPTO; Final Office Action dated Jan. 27, 2020 in U.S. Appl. No. 14/219,839.
- USPTO; Non-Final Office Action dated Nov. 25, 2015 in U.S. Appl. No. 14/219,879.
- USPTO; Final Office action dated May 19, 2016 in U.S. Appl. No. 14/219,879.

(56)

References Cited

OTHER PUBLICATIONS

- USPTO; Advisory Action dated Aug. 22, 2016 in U.S. Appl. No. 14/219,879.
- USPTO; Non-Final Office Action dated Dec. 23, 2016 in U.S. Appl. No. 14/219,879.
- USPTO; Final Office action dated Jul. 6, 2017 in U.S. Appl. No. 14/219,879.
- USPTO; Advisory Action dated Oct. 5, 2017 in U.S. Appl. No. 14/219,879.
- USPTO; Non-Final Office Action dated Apr. 6, 2018 in U.S. Appl. No. 14/219,879.
- USPTO; Final Office Action dated Nov. 2, 2018 in U.S. Appl. No. 14/219,879.
- USPTO; Advisory Action dated Jan. 22, 2019 in U.S. Appl. No. 14/219,879.
- USPTO; Non-Final Office Action dated Jun. 24, 2019 in U.S. Appl. No. 14/219,879.
- USPTO; Final Office Action dated Jan. 13, 2020 in U.S. Appl. No. 14/219,879.
- USPTO; Non-Final Office Action dated Sep. 18, 2015 in U.S. Appl. No. 14/244,689.
- USPTO; Notice of Allowance dated Feb. 11, 2016 in U.S. Appl. No. 14/244,689.
- USPTO; Non-Final Office Action dated Oct. 7, 2015 in U.S. Appl. No. 14/246,969.
- USPTO; Final Office Action dated May 4, 2016 in U.S. Appl. No. 14/246,969.
- USPTO; Advisory Action dated Aug. 2, 2016 in U.S. Appl. No. 14/246,969.
- USPTO; Non-Final Office Action dated Aug. 12, 2016 in U.S. Appl. No. 14/246,969.
- USPTO; Notice of Allowance dated Feb. 27, 2017 in U.S. Appl. No. 14/246,969.
- USPTO; Non-Final Office Action dated Nov. 20, 2015 in U.S. Appl. No. 14/260,701.
- USPTO; Notice of Allowance dated Jun. 2, 2016 in U.S. Appl. No. 14/260,701.
- USPTO; Notice of Allowance dated Feb. 23, 2016 in U.S. Appl. No. 14/327,134.
- USPTO; Non-Final Office Action dated Aug. 19, 2015 in U.S. Appl. No. 14/268,348.
- USPTO; Non-Final Office Action dated Jan. 6, 2016 in U.S. Appl. No. 14/268,348.
- USPTO; Final Office Action dated Apr. 29, 2016 in U.S. Appl. No. 14/268,348.
- USPTO; Notice of Allowance dated Aug. 19, 2016 in U.S. Appl. No. 14/268,348.
- USPTO; Notice of Allowance dated Aug. 30, 2016 in U.S. Appl. No. 14/268,348.
- USPTO; Non-Final Office Action dated Oct. 20, 2015 in U.S. Appl. No. 14/281,477.
- USPTO; Notice of Allowance dated Mar. 28, 2016 in U.S. Appl. No. 14/281,477.
- USPTO; Non-Final Office Action dated Jan. 13, 2017 in U.S. Appl. No. 14/444,744.
- USPTO; Final Office Action dated Jul. 10, 2017 in U.S. Appl. No. 14/444,744.
- USPTO; Non-Final Office Action dated Nov. 29, 2017 in U.S. Appl. No. 14/444,744.
- USPTO; Final Office Action dated Mar. 28, 2018 in U.S. Appl. No. 14/444,744.
- USPTO; Non-Final Office Action dated Jul. 27, 2018 in U.S. Appl. No. 14/444,744.
- USPTO; Final Office Action dated Feb. 7, 2019 in U.S. Appl. No. 14/444,744.
- USPTO; Non-Final Office Action dated Aug. 8, 2019 in U.S. Appl. No. 14/444,744.
- USPTO; Final Office Action dated Feb. 20, 2020 in U.S. Appl. No. 14/444,744.
- USPTO; Non-Final Office Action dated May 18, 2016 in U.S. Appl. No. 14/449,838.
- USPTO; Notice of Allowance dated Nov. 28, 2016 in U.S. Appl. No. 14/449,838.
- USPTO; Non-Final Office Action dated Feb. 12, 2015 in U.S. Appl. No. 14/457,058.
- USPTO; Final Office Action dated Jul. 14, 2015 in U.S. Appl. No. 14/457,058.
- USPTO; Non-Final Office Action dated Nov. 6, 2015 in U.S. Appl. No. 14/457,058.
- USPTO; Advisory Action dated Nov. 6, 2015 in U.S. Appl. No. 14/457,058.
- USPTO; Final Office Acton dated Jun. 17, 2016 in U.S. Appl. No. 14/457,058.
- USPTO; Advisory Action dated Sep. 21, 2016 in U.S. Appl. No. 14/457,058.
- USPTO; Non-Final Office Action dated Oct. 6, 2016 in U.S. Appl. No. 14/457,058.
- USPTO; Final Office Acton dated May 4, 2017 in U.S. Appl. No. 14/457,058.
- USPTO; Non-Final Office Action dated Oct. 19, 2017 in U.S. Appl. No. 14/457,058.
- USPTO; Final Office Action dated Jun. 14, 2018 in U.S. Appl. No. 14/457,058.
- USPTO; Non-Final Office Action dated Jan. 11, 2019 in U.S. Appl. No. 14/457,058.
- USPTO; Final Office Action dated Jun. 25, 2019 in U.S. Appl. No. 14/457,058.
- USPTO; Non-Final Office Action dated Oct. 31, 2019 in U.S. Appl. No. 14/457,058.
- USPTO; Non-Final Office Action dated Sep. 16, 2016 in U.S. Appl. No. 14/465,252.
- USPTO; Final Office Action dated Nov. 1, 2016 in U.S. Appl. No. 14/465,252.
- USPTO; Non-Final Office Action dated Mar. 6, 2017 in U.S. Appl. No. 14/465,252.
- USPTO; Final Office Action dated Jun. 9, 2017 in U.S. Appl. No. 14/465,252.
- USPTO; Notice of Allowance dated Oct. 3, 2017 in U.S. Appl. No. 14/465,252.
- USPTO; Non-Final Office Action dated Nov. 24, 2015 in U.S. Appl. No. 14/498,036.
- USPTO; Final Office Action dated Apr. 5, 2016 in U.S. Appl. No. 14/498,036.
- USPTO; Advisory Action dated Jun. 16, 2016 in U.S. Appl. No. 14/498,036.
- USPTO; Notice of Allowance dated Aug. 17, 2016 in U.S. Appl. No. 14/498,036.
- USPTO; Non-Final Office Action dated Apr. 10, 2015 in U.S. Appl. No. 14/505,290.
- USPTO; Notice of Allowance dated Aug. 21, 2015 in U.S. Appl. No. 14/505,290.
- USPTO; Non-Final Office Action dated Dec. 17, 2015 in U.S. Appl. No. 14/508,296.
- USPTO; Final Office Action dated May 26, 2016 in U.S. Appl. No. 14/508,296.
- USPTO; Advisory Action dated Aug. 17, 2016 in U.S. Appl. No. 14/508,296.
- USPTO; Non-Final Office Action dated Sep. 8, 2016 in U.S. Appl. No. 14/508,296.
- USPTO; Final Office Action dated Dec. 7, 2016 in U.S. Appl. No. 14/508,296.
- USPTO; Notice of Allowance dated Jan. 27, 2017 in U.S. Appl. No. 14/508,296.
- USPTO; Non-Final Office Action dated Apr. 6, 2017 in U.S. Appl. No. 14/508,489.
- USPTO; Final Office Action dated Oct. 4, 2017 in U.S. Appl. No. 14/508,489.
- USPTO; Non-Final Office Action dated May 15, 2018 in U.S. Appl. No. 14/508,489.
- USPTO; Final Office Action dated Nov. 28, 2018 in U.S. Appl. No. 14/508,489.

(56)

References Cited

OTHER PUBLICATIONS

- USPTO; Non-Final Office Action dated Apr. 4, 2019 in U.S. Appl. No. 14/508,489.
- USPTO; Final Office Action dated Aug. 20, 2019 in U.S. Appl. No. 14/508,489.
- USPTO; Advisory Action dated Oct. 28, 2019 in U.S. Appl. No. 14/508,489.
- USPTO; Non-Final Office Action dated Mar. 5, 2020 in U.S. Appl. No. 14/508,489.
- USPTO; Non-Final Office Action dated Jan. 16, 2015 in U.S. Appl. No. 14/563,044.
- USPTO; Final Office Action dated Jul. 16, 2015 in U.S. Appl. No. 14/563,044.
- USPTO; Notice of Allowance dated Oct. 15, 2015 in U.S. Appl. No. 14/563,044.
- USPTO; Notice of Allowance dated Dec. 2, 2015 in U.S. Appl. No. 14/563,044.
- USPTO; Non-Final Office Action dated May 4, 2016 in U.S. Appl. No. 14/568,647.
- USPTO; Final Office Action dated Sep. 29, 2016 in U.S. Appl. No. 14/568,647.
- USPTO; Advisory Action dated Dec. 21, 2016 in U.S. Appl. No. 14/568,647.
- USPTO; Non-Final Office Action dated Feb. 2, 2017 in U.S. Appl. No. 14/568,647.
- USPTO; Final Office Action dated May 19, 2017 in U.S. Appl. No. 14/568,647.
- USPTO; Non-Final Office Action dated Sep. 14, 2017 in U.S. Appl. No. 14/568,647.
- USPTO; Final Office Action dated Jan. 23, 2018 in U.S. Appl. No. 14/568,647.
- USPTO; Advisory Action dated Apr. 12, 2018 in U.S. Appl. No. 14/568,647.
- USPTO; Non-Final Office Action dated May 25, 2018 in U.S. Appl. No. 14/568,647.
- USPTO; Non-Final Office Action dated Oct. 1, 2015 in U.S. Appl. No. 14/571,126.
- USPTO; Final Office Action dated Feb. 22, 2016 in U.S. Appl. No. 14/571,126.
- USPTO; Notice of Allowance dated May 18, 2016 in U.S. Appl. No. 14/571,126.
- USPTO; Notice of Allowance dated Jun. 2, 2016 in U.S. Appl. No. 14/571,126.
- USPTO; Non-Final Office Action dated Nov. 25, 2015 in U.S. Appl. No. 14/598,532.
- USPTO; Notice of Allowance dated May 16, 2016 in U.S. Appl. No. 14/598,532.
- USPTO; Non-Final Office Action dated Jan. 15, 2016 in U.S. Appl. No. 14/606,364.
- USPTO; Final Office Action dated Jun. 14, 2016 in U.S. Appl. No. 14/606,364.
- USPTO; Advisory Action dated Aug. 25, 2016 in U.S. Appl. No. 14/606,364.
- USPTO; Final Office Action dated Jan. 12, 2017 in U.S. Appl. No. 14/606,364.
- USPTO; Non-Final Office Action dated May 10, 2017 in U.S. Appl. No. 14/606,364.
- USPTO; Notice of Allowance dated Aug. 16, 2017 in U.S. Appl. No. 14/606,364.
- USPTO; Non-Final Office Action dated Mar. 3, 2016 in U.S. Appl. No. 14/622,603.
- USPTO; Notice of Allowance dated Aug. 2, 2016 in U.S. Appl. No. 14/622,603.
- USPTO; Notice of Allowance dated Feb. 16, 2016 in U.S. Appl. No. 14/634,342.
- USPTO; Non-Final Office Action dated Oct. 19, 2017 in U.S. Appl. No. 14/645,234.
- USPTO; Non-Final Office Action dated May 16, 2018 in U.S. Appl. No. 14/645,234.
- USPTO; Final Office Action dated Aug. 10, 2018 in U.S. Appl. No. 14/645,234.
- USPTO; Notice of Allowance dated Aug. 15, 2019 in U.S. Appl. No. 14/645,234.
- USPTO; Non-Final Office Action dated Jun. 7, 2017 in U.S. Appl. No. 14/656,588.
- USPTO; Final Office Action dated Dec. 26, 2017 in U.S. Appl. No. 14/656,588.
- USPTO; Non-Final Office Action dated Apr. 6, 2018 in U.S. Appl. No. 14/656,588.
- USPTO; Notice of Allowance dated Nov. 19, 2018 in U.S. Appl. No. 14/656,588.
- USPTO; Non-Final Office Action dated Mar. 21, 2016 in U.S. Appl. No. 14/659,152.
- USPTO; Final Office Action dated Jul. 29, 2016 in U.S. Appl. No. 14/659,152.
- USPTO; Notice of Allowance dated Nov. 22, 2016 in U.S. Appl. No. 14/659,152.
- USPTO; Non-Final Office Action dated Nov. 19, 2015 in U.S. Appl. No. 14/659,437.
- USPTO; Final Office Action dated Mar. 17, 2016 in U.S. Appl. No. 14/659,437.
- USPTO; Notice of Allowance dated May 31, 2016 in U.S. Appl. No. 14/659,437.
- USPTO; Non-Final Office Action dated Sep. 7, 2017 in U.S. Appl. No. 14/660,755.
- USPTO; Notice of Allowance dated Oct. 2, 2017 in U.S. Appl. No. 14/660,755.
- USPTO; Notice of Allowance dated Mar. 25, 2016 in U.S. Appl. No. 14/693,138.
- USPTO; Non-Final Office Action dated Aug. 3, 2017 in U.S. Appl. No. 14/752,712.
- USPTO; Final Office Action dated Nov. 29, 2017 in U.S. Appl. No. 14/752,712.
- USPTO; Advisory Action dated Feb. 15, 2018 in U.S. Appl. No. 14/752,712.
- USPTO; Non-Final Office Action dated Mar. 21, 2018 in U.S. Appl. No. 14/752,712.
- USPTO; Final Office Action dated Sep. 5, 2018 in U.S. Appl. No. 14/752,712.
- USPTO; Non-Final Office Action dated Dec. 28, 2018 in U.S. Appl. No. 14/752,712.
- USPTO; Notice of Allowance dated Jun. 11, 2019 in U.S. Appl. No. 14/752,712.
- USPTO; Non-Final Office Action dated Nov. 29, 2017 in U.S. Appl. No. 14/793,323.
- USPTO; Final Office Action dated Mar. 29, 2018 in U.S. Appl. No. 14/793,323.
- USPTO; Non-Final Office Action dated Aug. 10, 2018 in U.S. Appl. No. 14/793,323.
- USPTO; Final Office Action dated Feb. 25, 2019 in U.S. Appl. No. 14/793,323.
- USPTO; Non-Final Office Action dated Jun. 27, 2019 in U.S. Appl. No. 14/793,323.
- USPTO; Notice of Allowance dated Nov. 14, 2019 in U.S. Appl. No. 14/793,323.
- USPTO; Non-Final Office Action dated Jun. 16, 2017 in U.S. Appl. No. 14/798,136.
- USPTO; Notice of Allowance dated Oct. 5, 2017 in U.S. Appl. No. 14/798,136.
- USPTO; Non-Final Office Action dated Mar. 30, 2016 in U.S. Appl. No. 14/808,979.
- USPTO; Final Office Action dated Sep. 30, 2016 in U.S. Appl. No. 14/808,979.
- USPTO; Non-Final Office Action dated Dec. 20, 2016 in U.S. Appl. No. 14/808,979.
- USPTO; Final Office Action dated Jun. 8, 2017 in U.S. Appl. No. 14/808,979.
- USPTO; Non-Final Office Action dated Sep. 21, 2017 in U.S. Appl. No. 14/808,979.
- USPTO; Final Office Action dated Mar. 14, 2018 in U.S. Appl. No. 14/808,979.

(56)

References Cited

OTHER PUBLICATIONS

- USPTO; Notice of Allowance dated Jun. 27, 2018 in U.S. Appl. No. 14/808,979.
- USPTO; Non-Final Office Action dated Feb. 23, 2018 in U.S. Appl. No. 14/817,953.
- USPTO; Notice of Allowance dated Jul. 11, 2018 in U.S. Appl. No. 14/817,953.
- USPTO; Non-Final Office Action dated Sep. 1, 2016 in U.S. Appl. No. 14/827,177.
- USPTO; Notice of Allowance dated Jan. 27, 2017 in U.S. Appl. No. 14/827,177.
- USPTO; Non-Final Office Action dated Sep. 9, 2016 in U.S. Appl. No. 14/829,565.
- USPTO; Final Office Action dated Feb. 9, 2017 in U.S. Appl. No. 14/829,565.
- USPTO; Advisory Action dated Apr. 20, 2017 in U.S. Appl. No. 14/829,565.
- USPTO; Non-Final Office Action dated Sep. 19, 2017 in U.S. Appl. No. 14/829,565.
- USPTO; Final Office Action dated Mar. 5, 2018 in U.S. Appl. No. 14/829,565.
- USPTO; Advisory Action dated Aug. 10, 2018 in U.S. Appl. No. 14/829,565.
- USPTO; Non-Final Office Action dated Sep. 6, 2018 in U.S. Appl. No. 14/829,565.
- USPTO; Final Office Action dated Apr. 18, 2019 in U.S. Appl. No. 14/829,565.
- USPTO; Advisory Action dated Jul. 22, 2019 in U.S. Appl. No. 14/829,565.
- USPTO; Non-Final Office Action dated Sep. 19, 2019 in U.S. Appl. No. 14/829,565.
- USPTO; Final Office Action dated Mar. 3, 2020 in U.S. Appl. No. 14/829,565.
- USPTO; Non-Final Office Action dated Apr. 29, 2016 in U.S. Appl. No. 14/835,637.
- USPTO; Final Office Action dated Nov. 25, 2016 in U.S. Appl. No. 14/835,637.
- USPTO; Advisory Action dated Feb. 14, 2017 in U.S. Appl. No. 14/835,637.
- USPTO; Notice of Allowance dated Apr. 25, 2017 in U.S. Appl. No. 14/835,637.
- USPTO; Non-Final Office Action dated Jul. 29, 2016 in U.S. Appl. No. 14/884,695.
- USPTO; Final Office Action dated Feb. 9, 2017 in U.S. Appl. No. 14/884,695.
- USPTO; Advisory Action dated Apr. 20, 2017 in U.S. Appl. No. 14/884,695.
- USPTO; Non-Final Office Action dated May 18, 2017 in U.S. Appl. No. 14/884,695.
- USPTO; Notice of Allowance dated Oct. 20, 2017 in U.S. Appl. No. 14/884,695.
- USPTO; Non-Final Office Action dated May 18, 2017 in U.S. Appl. No. 14/886,571.
- USPTO; Final Office Action dated Sep. 21, 2017 in U.S. Appl. No. 14/886,571.
- USPTO; Notice of Allowance dated Dec. 6, 2017 in U.S. Appl. No. 14/886,571.
- USPTO; Non-Final Office Action dated Dec. 1, 2016 in U.S. Appl. No. 14/919,536.
- USPTO; Final Office Action dated Mar. 28, 2017 in U.S. Appl. No. 14/919,536.
- USPTO; Non-Final Office Action dated Aug. 29, 2017 in U.S. Appl. No. 14/919,536.
- USPTO; Final Office Action dated May 11, 2018 in U.S. Appl. No. 14/919,536.
- USPTO; Notice of Allowance dated Oct. 4, 2018 in U.S. Appl. No. 14/919,536.
- USPTO; Notice of Allowance dated Nov. 19, 2018 in U.S. Appl. No. 14/919,536.
- USPTO; Non-Final Office Action dated May 3, 2016 in U.S. Appl. No. 14/937,053.
- USPTO; Notice of Allowance dated Jul. 26, 2016 in U.S. Appl. No. 14/937,053.
- USPTO; Non-Final Office Action dated Dec. 15, 2016 in U.S. Appl. No. 14/938,180.
- USPTO; Notice of Allowance dated Nov. 9, 2017 in U.S. Appl. No. 14/938,180.
- USPTO; Non-Final Office Action dated Apr. 14, 2017 in U.S. Appl. No. 14/956,115.
- USPTO; Final Office Action dated Jul. 21, 2017 in U.S. Appl. No. 14/956,115.
- USPTO; Notice of Allowance dated Dec. 14, 2017 in U.S. Appl. No. 14/956,115.
- USPTO; Notice of Allowance dated Feb. 3, 2017 in U.S. Appl. No. 14/977,291.
- USPTO; Non-Final Office Action dated Aug. 12, 2016 in U.S. Appl. No. 14/981,434.
- USPTO; Notice of Allowance dated Nov. 21, 2016 in U.S. Appl. No. 14/981,434.
- USPTO; Non-Final Office Action dated Jan. 12, 2017 in U.S. Appl. No. 14/981,468.
- USPTO; Notice of Allowance dated Jun. 7, 2017 in U.S. Appl. No. 14/981,468.
- USPTO; Non-Final Office Action dated Mar. 22, 2016 in U.S. Appl. No. 14/987,420.
- USPTO; Final Office Action dated Jun. 10, 2016 in U.S. Appl. No. 14/987,420.
- USPTO; Non-Final Office Action dated Dec. 14, 2016 in U.S. Appl. No. 14/997,683.
- USPTO; Final Office Action dated Apr. 14, 2017 in U.S. Appl. No. 14/997,683.
- USPTO; Non-Final Office Action dated Sep. 1, 2017 in U.S. Appl. No. 14/997,683.
- USPTO; Final Office Action dated Feb. 6, 2018 in U.S. Appl. No. 14/997,683.
- USPTO; Advisory Action dated May 2, 2018 in U.S. Appl. No. 14/997,683.
- USPTO; Non-Final Office Action dated Jun. 20, 2018 in U.S. Appl. No. 14/997,683.
- USPTO; Final Office Action dated Dec. 10, 2018 in U.S. Appl. No. 14/997,683.
- USPTO; Notice of Allowance dated Mar. 25, 2019 in U.S. Appl. No. 14/997,683.
- USPTO; Non-Final Office Action dated Sep. 23, 2016 in U.S. Appl. No. 15/048,422.
- USPTO; Notice of Allowance dated May 4, 2017 in U.S. Appl. No. 15/048,422.
- USPTO; Non-Final Office Action dated Aug. 4, 2017 in U.S. Appl. No. 15/050,159.
- USPTO; Notice of Allowance dated Feb. 7, 2018 in U.S. Appl. No. 15/050,159.
- USPTO; Non-Final Office Action dated Apr. 22, 2016 in U.S. Appl. No. 15/055,122.
- USPTO; Notice of Allowance dated Sep. 15, 2016 in U.S. Appl. No. 15/055,122.
- USPTO; Non-Final Office Action dated Feb. 20, 2018 in U.S. Appl. No. 15/060,412.
- USPTO; Final Office Action dated Oct. 19, 2018 in U.S. Appl. No. 15/060,412.
- USPTO; Non-Final Office Action dated Jun. 3, 2019 in U.S. Appl. No. 15/060,412.
- USPTO; Final Office Action dated Dec. 26, 2019 in U.S. Appl. No. 15/060,412.
- USPTO; Notice of Allowance dated Mar. 5, 2020 in U.S. Appl. No. 15/060,412.
- USPTO; Non-Final Office Action dated Aug. 27, 2018 in U.S. Appl. No. 15/067,028.
- USPTO; Notice of Allowance dated Dec. 21, 2018 in U.S. Appl. No. 15/067,028.
- USPTO; Non-Final Office Action dated Sep. 26, 2018 in U.S. Appl. No. 15/074,813.

(56)

References Cited

OTHER PUBLICATIONS

- USPTO; Notice of Allowance dated Feb. 25, 2019 in U.S. Appl. No. 15/074,813.
- USPTO; Non-Final Office Action dated Jan. 9, 2018 in U.S. Appl. No. 15/135,224.
- USPTO; Notice of Allowance dated Jun. 29, 2018 in U.S. Appl. No. 15/135,224.
- USPTO; Non-Final Office Action dated Jan. 9, 2018 in U.S. Appl. No. 15/135,258.
- USPTO; Final Office Action dated Jul. 6, 2018 in U.S. Appl. No. 15/135,258.
- USPTO; Non-Final Office Action dated Nov. 23, 2018 in U.S. Appl. No. 15/135,258.
- USPTO; Final Office Action dated Mar. 14, 2019 in U.S. Appl. No. 15/135,258.
- USPTO; Non-Final Office Action dated Jul. 19, 2019 in U.S. Appl. No. 15/135,258.
- USPTO; Final Office Action dated Oct. 24, 2019 in U.S. Appl. No. 15/135,258.
- USPTO; Advisory Action dated Jan. 3, 2020 in U.S. Appl. No. 15/135,258.
- USPTO; Non-Final Office Action dated Feb. 13, 2020 in U.S. Appl. No. 15/135,258.
- USPTO; Non-Final Office Action dated Jan. 9, 2018 in U.S. Appl. No. 15/135,333.
- USPTO; Notice of Allowance dated Sep. 14, 2018 in U.S. Appl. No. 15/135,333.
- USPTO; Non-Final Office Action dated Nov. 21, 2016 in U.S. Appl. No. 15/144,481.
- USPTO; Final Office Action dated May 26, 2017 in U.S. Appl. No. 15/144,481.
- USPTO; Non-Final Office Action dated Sep. 21, 2017 in U.S. Appl. No. 15/144,481.
- USPTO; Notice of Allowance dated Mar. 26, 2018 in U.S. Appl. No. 15/144,481.
- USPTO; Notice of Allowance dated Apr. 11, 2018 in U.S. Appl. No. 15/144,481.
- USPTO; Non-Final Office Action dated Apr. 13, 2017 in U.S. Appl. No. 15/144,506.
- USPTO; Final Office Action dated Oct. 10, 2017 in U.S. Appl. No. 15/144,506.
- USPTO; Final Office Action dated Jul. 26, 2018 in U.S. Appl. No. 15/144,506.
- USPTO; Notice of Allowance dated Mar. 13, 2019 in U.S. Appl. No. 15/144,506.
- USPTO; Non-Final Office Action dated Oct. 9, 2018 in U.S. Appl. No. 15/182,504.
- USPTO; Final Office Action dated Mar. 28, 2019 in U.S. Appl. No. 15/182,504.
- USPTO; Notice of Allowance dated Jul. 17, 2019 in U.S. Appl. No. 15/182,504.
- USPTO; Non-Final Office Action dated Nov. 28, 2016 in U.S. Appl. No. 15/203,632.
- USPTO; Final Office Action dated Jun. 7, 2017 in U.S. Appl. No. 15/203,632.
- USPTO; Advisory Action dated Aug. 23, 2017 in U.S. Appl. No. 15/203,632.
- USPTO; Notice of Allowance dated Sep. 20, 2017 in U.S. Appl. No. 15/203,632.
- USPTO; Non-Final Office Action dated Nov. 29, 2016 in U.S. Appl. No. 15/203,642.
- USPTO; Final Office Action dated Apr. 13, 2017 in U.S. Appl. No. 15/203,642.
- USPTO; Advisory Action dated Jun. 22, 2017 in U.S. Appl. No. 15/203,642.
- USPTO; Notice of Allowance dated Aug. 7, 2017 in U.S. Appl. No. 15/203,642.
- USPTO; Non-Final Office Action dated Jun. 1, 2017 in U.S. Appl. No. 15/205,827.
- USPTO; Final Office Action dated Oct. 16, 2017 in U.S. Appl. No. 15/205,827.
- USPTO; Non-Final Office Action dated May 14, 2018 in U.S. Appl. No. 15/205,827.
- USPTO; Final Office Action dated Oct. 9, 2018 in U.S. Appl. No. 15/205,827.
- USPTO; Non-Final Office Action dated Mar. 28, 2019 in U.S. Appl. No. 15/205,827.
- USPTO; Final Office Action dated Aug. 9, 2019 in U.S. Appl. No. 15/205,827.
- USPTO; Advisory Action dated Oct. 22, 2019 in U.S. Appl. No. 15/205,827.
- USPTO; Notice of Allowance dated Dec. 3, 2019 in U.S. Appl. No. 15/205,827.
- USPTO; Non-Final Office Action dated Mar. 31, 2017 in U.S. Appl. No. 15/205,890.
- USPTO; Notice of Allowance dated Oct. 16, 2017 in U.S. Appl. No. 15/205,890.
- USPTO; Non-Final Office Action dated Jan. 20, 2017 in U.S. Appl. No. 15/210,256.
- USPTO; Notice of Allowance dated May 18, 2017 in U.S. Appl. No. 15/210,256.
- USPTO; Notice of Allowance dated Jul. 24, 2017 in U.S. Appl. No. 15/210,256.
- USPTO; Non-Final Office Action dated Apr. 21, 2017 in U.S. Appl. No. 15/222,715.
- USPTO; Notice of Allowance dated Jul. 14, 2017 in U.S. Appl. No. 15/222,715.
- USPTO; Notice of Allowance dated Sep. 27, 2017 in U.S. Appl. No. 15/222,715.
- USPTO; Non-Final Office Action dated Feb. 3, 2017 in U.S. Appl. No. 15/222,738.
- USPTO; Notice of Allowance dated May 22, 2017 in U.S. Appl. No. 15/222,738.
- USPTO; Notice of Allowance dated Aug. 23, 2017 in U.S. Appl. No. 15/222,738.
- USPTO; Non-Final Office Action dated Jan. 17, 2017 in U.S. Appl. No. 15/222,749.
- USPTO; Final Office Action dated May 5, 2017 in U.S. Appl. No. 15/222,749.
- USPTO; Non-Final Office Action dated Sep. 7, 2017 in U.S. Appl. No. 15/222,749.
- USPTO; Final Office Action dated Jun. 4, 2018 in U.S. Appl. No. 15/222,749.
- USPTO; Notice of Allowance dated Aug. 30, 2018 in U.S. Appl. No. 15/222,749.
- USPTO; Non-Final Office Action dated Jan. 3, 2017 in U.S. Appl. No. 15/222,780.
- USPTO; Final Office Action dated May 5, 2017 in U.S. Appl. No. 15/222,780.
- USPTO; Non-Final Office Action dated Sep. 7, 2017 in U.S. Appl. No. 15/222,780.
- USPTO; Final Office Action dated May 17, 2018 in U.S. Appl. No. 15/222,780.
- USPTO; Non-Final Office Action dated Oct. 1, 2018 in U.S. Appl. No. 15/222,780.
- USPTO; Notice of Allowance dated Apr. 19, 2019 in U.S. Appl. No. 15/222,780.
- USPTO; Notice of Allowance dated Jul. 12, 2018 in U.S. Appl. No. 15/254,605.
- USPTO; Non-Final Office Action dated Aug. 28, 2017 in U.S. Appl. No. 15/254,724.
- USPTO; Notice of Allowance dated Jan. 17, 2018 in U.S. Appl. No. 15/254,724.
- USPTO; Notice of Allowance dated Apr. 2, 2018 in U.S. Appl. No. 15/254,724.
- USPTO; Non-Final Office Action dated May 22, 2018 in U.S. Appl. No. 15/262,990.
- USPTO; Non-Final Office Action dated Sep. 13, 2018 in U.S. Appl. No. 15/262,990.
- USPTO; Non-Final Office Action dated Jan. 30, 2019 in U.S. Appl. No. 15/262,990.

(56)

References Cited

OTHER PUBLICATIONS

- USPTO; Final Office Action dated May 13, 2019 in U.S. Appl. No. 15/262,990.
- USPTO; Advisory Action dated Jul. 22, 2019 in U.S. Appl. No. 15/262,990.
- USPTO; Non-Final Office Action dated Aug. 5, 2019 in U.S. Appl. No. 15/262,990.
- USPTO; Final Office Action dated Nov. 19, 2019 in U.S. Appl. No. 15/262,990.
- USPTO; Advisory Action dated Jan. 30, 2020 in U.S. Appl. No. 15/262,990.
- USPTO; Non-Final Office Action dated Aug. 3, 2018 in U.S. Appl. No. 15/273,488.
- USPTO; Final Office Action dated Jan. 11, 2019 in U.S. Appl. No. 15/273,488.
- USPTO; Notice of Allowance dated Apr. 19, 2019 in U.S. Appl. No. 15/273,488.
- USPTO; Non-Final Office Action dated Jul. 2, 2018 in U.S. Appl. No. 15/286,503.
- USPTO; Final Office Action dated Feb. 7, 2019 in U.S. Appl. No. 15/286,503.
- USPTO; Non-Final Office Action dated Jun. 27, 2019 in U.S. Appl. No. 15/286,503.
- USPTO; Final Office Action dated Jan. 6, 2020 in U.S. Appl. No. 15/286,503.
- USPTO; Advisory Action dated Mar. 31, 2020 in U.S. Appl. No. 15/286,503.
- USPTO; Non-Final Office Action dated Dec. 14, 2018 in U.S. Appl. No. 15/340,512.
- USPTO; Notice of Allowance dated May 24, 2019 in U.S. Appl. No. 15/340,512.
- USPTO; Non-Final Office Action dated Oct. 23, 2017 in U.S. Appl. No. 15/377,439.
- USPTO; Final Office Action dated Apr. 16, 2018 in U.S. Appl. No. 15/377,439.
- USPTO; Advisory Action dated Aug. 8, 2018 in U.S. Appl. No. 15/377,439.
- USPTO; Non-Final Office Action dated Nov. 14, 2018 in U.S. Appl. No. 15/377,439.
- USPTO; Final Office Action dated Jun. 25, 2019 in U.S. Appl. No. 15/377,439.
- USPTO; Non-Final Office Action dated Nov. 7, 2019 in U.S. Appl. No. 15/377,439.
- USPTO; Notice of Allowance dated Aug. 8, 2017 in U.S. Appl. No. 15/380,895.
- USPTO; Notice of Allowance dated Oct. 11, 2017 in U.S. Appl. No. 15/380,895.
- USPTO; Non-Final Office Action dated May 31, 2019 in U.S. Appl. No. 15/380,909.
- USPTO; Final Office Action dated Dec. 12, 2019 in U.S. Appl. No. 15/380,909.
- USPTO; Non-Final Office Action dated Jan. 4, 2018 in U.S. Appl. No. 15/380,921.
- USPTO; Final Office Action dated Jun. 28, 2018 in U.S. Appl. No. 15/380,921.
- USPTO; Non-Final Office Action dated Feb. 25, 2019 in U.S. Appl. No. 15/380,921.
- USPTO; Final Office Action dated Sep. 18, 2019 in U.S. Appl. No. 15/380,921.
- USPTO; Non-Final Office Action dated Jan. 15, 2020 in U.S. Appl. No. 15/380,921.
- USPTO; Non-Final Office Action dated Oct. 3, 2017 in U.S. Appl. No. 15/388,410.
- USPTO; Final Office Action dated May 15, 2018 in U.S. Appl. No. 15/388,410.
- USPTO; Notice of Allowance dated Nov. 14, 2018 in U.S. Appl. No. 15/388,410.
- USPTO; Notice of Allowance dated Dec. 28, 2018 in U.S. Appl. No. 15/388,410.
- USPTO; Non-Final Office Action dated Aug. 11, 2017 in U.S. Appl. No. 15/397,237.
- USPTO; Notice of Allowance dated Dec. 22, 2017 in U.S. Appl. No. 15/397,237.
- USPTO; Non-Final Office Action dated Apr. 12, 2017 in U.S. Appl. No. 15/397,319.
- USPTO; Final Office Action dated Jul. 12, 2017 in U.S. Appl. No. 15/397,319.
- USPTO; Notice of Allowance dated Dec. 15, 2017 in U.S. Appl. No. 15/397,319.
- USPTO; Non-Final Office Action dated Feb. 5, 2019 in U.S. Appl. No. 15/402,993.
- USPTO; Final Office Action dated May 21, 2019 in U.S. Appl. No. 15/402,993.
- USPTO; Advisory Action dated Jul. 29, 2019 in U.S. Appl. No. 15/402,993.
- USPTO; Non-Final Office Action dated Oct. 24, 2019 in U.S. Appl. No. 15/402,993.
- USPTO; Final Office Action dated Feb. 19, 2020 in U.S. Appl. No. 15/402,993.
- USPTO; Advisory Action dated Apr. 2, 2020 in U.S. Appl. No. 15/402,993.
- USPTO; Non-Final Office Action dated Sep. 20, 2018 in U.S. Appl. No. 15/410,503.
- USPTO; Final Office Action dated Feb. 4, 2019 in U.S. Appl. No. 15/410,503.
- USPTO; Non-Final Office Action dated Apr. 25, 2019 in U.S. Appl. No. 15/410,503.
- USPTO; Notice of Allowance dated Aug. 14, 2019 in U.S. Appl. No. 15/410,503.
- USPTO; Non-Final Office Action dated Aug. 7, 2018 in U.S. Appl. No. 15/428,808.
- USPTO; Final Office Action dated Jan. 11, 2019 in U.S. Appl. No. 15/428,808.
- USPTO; Notice of Allowance dated Apr. 25, 2019 in U.S. Appl. No. 15/428,808.
- USPTO; Non-Final Office Action dated Apr. 6, 2018 in U.S. Appl. No. 15/434,051.
- USPTO; Final Office Action dated Aug. 29, 2018 in U.S. Appl. No. 15/434,051.
- USPTO; Advisory Action dated Dec. 4, 2018 in U.S. Appl. No. 15/434,051.
- USPTO; Non-Final Office Action dated Jan. 25, 2019 in U.S. Appl. No. 15/434,051.
- USPTO; Notice of Allowance dated Jun. 3, 2019 in U.S. Appl. No. 15/434,051.
- USPTO; Notice of Allowance dated Oct. 6, 2017 in U.S. Appl. No. 15/450,199.
- USPTO; Non-Final Office Action dated Dec. 15, 2017 in U.S. Appl. No. 15/466,149.
- USPTO; Notice of Allowance dated Apr. 20, 2018 in U.S. Appl. No. 15/466,149.
- USPTO; Non-Final Office Action dated Apr. 6, 2018 in U.S. Appl. No. 15/472,750.
- USPTO; Notice of Allowance dated Nov. 30, 2018 in U.S. Appl. No. 15/472,750.
- USPTO; Non-Final Office Action dated Oct. 4, 2017 in U.S. Appl. No. 15/489,453.
- USPTO; Final Office Action dated Apr. 19, 2018 in U.S. Appl. No. 15/489,453.
- USPTO; Non-Final Office Action dated Sep. 10, 2018 in U.S. Appl. No. 15/489,453.
- USPTO; Final Office Action dated Feb. 27, 2019 in U.S. Appl. No. 15/489,453.
- USPTO; Non-Final Office Action dated Jun. 5, 2019 in U.S. Appl. No. 15/489,453.
- USPTO; Notice of Allowance dated Oct. 7, 2019 in U.S. Appl. No. 15/489,453.
- USPTO; Notice of Allowance dated Dec. 19, 2017 in U.S. Appl. No. 15/489,660.
- USPTO; Non-Final Office Action dated Dec. 6, 2017 in U.S. Appl. No. 15/476,035.

(56)

References Cited

OTHER PUBLICATIONS

- USPTO; Notice of Allowance dated Mar. 21, 2018 in U.S. Appl. No. 15/476,035.
- USPTO; Notice of Allowance dated Aug. 14, 2018 in U.S. Appl. No. 15/476,035.
- USPTO; Final Office Action dated May 1, 2019 in U.S. Appl. No. 15/491,726.
- USPTO; Non-Final Office Action dated May 31, 2018 in U.S. Appl. No. 15/491,726.
- USPTO; Non-Final Office Action dated Oct. 3, 2019 in U.S. Appl. No. 15/491,726.
- USPTO; Non-Final Office Action dated Jan. 16, 2018 in U.S. Appl. No. 15/499,647.
- USPTO; Notice of Allowance dated May 23, 2018 in U.S. Appl. No. 15/499,647.
- USPTO; Non-Final Office Action dated Jun. 21, 2018 in U.S. Appl. No. 15/499,647.
- USPTO; Notice of Allowance dated Nov. 1, 2018 in U.S. Appl. No. 15/499,647.
- USPTO; Notice of Allowance dated Nov. 15, 2018 in U.S. Appl. No. 15/499,647.
- USPTO; Office Action dated Aug. 30, 2018 in U.S. Appl. No. 15/589,849.
- USPTO; Final Office Action dated Mar. 6, 2019 in U.S. Appl. No. 15/589,849.
- USPTO; Non-Final Office Action dated Jun. 28, 2019 in U.S. Appl. No. 15/589,849.
- USPTO; Final Office Action dated Jan. 8, 2020 in U.S. Appl. No. 15/589,849.
- USPTO; Notice of Allowance dated Feb. 28, 2020 in U.S. Appl. No. 15/589,849.
- USPTO; Office Action dated May 3, 2018 in U.S. Appl. No. 15/589,861.
- USPTO; Non-Final Office Action dated Dec. 21, 2018 in U.S. Appl. No. 15/589,861.
- USPTO; Final Office Action dated Jun. 26, 2019 in U.S. Appl. No. 15/589,861.
- USPTO; Advisory Action dated Sep. 20, 2019 in U.S. Appl. No. 15/589,861.
- USPTO; Non-Final Office Action dated Jan. 13, 2020 in U.S. Appl. No. 15/589,861.
- USPTO; Non-Final Office Action dated Apr. 4, 2018 in U.S. Appl. No. 15/592,730.
- USPTO; Final Office Action dated Nov. 16, 2018 in U.S. Appl. No. 15/592,730.
- USPTO; Advisory Action dated Mar. 15, 2019 in U.S. Appl. No. 15/592,730.
- USPTO; Notice of Allowance dated Aug. 21, 2019 in U.S. Appl. No. 15/592,730.
- USPTO; Non-Final Office Action dated Mar. 7, 2019 in U.S. Appl. No. 15/598,169.
- USPTO; Final Office Action dated Jun. 25, 2019 in U.S. Appl. No. 15/598,169.
- USPTO; Notice of Allowance dated Sep. 11, 2019 in U.S. Appl. No. 15/598,169.
- USPTO; Non-Final Office Action dated Mar. 10, 2020 in U.S. Appl. No. 15/611,707.
- USPTO; Ex Parte Quayle Action dated Mar. 21, 2019 in U.S. Appl. No. 15/615,489.
- USPTO; Non-Final Office Action dated Sep. 4, 2019 in U.S. Appl. No. 15/615,489.
- USPTO; Notice of Allowance dated Feb. 28, 2020 in U.S. Appl. No. 15/615,489.
- USPTO; Non-Final Office Action dated Feb. 1, 2019 in U.S. Appl. No. 15/627,189.
- USPTO; Notice of Allowance dated May 21, 2019 in U.S. Appl. No. 15/627,189.
- USPTO; Non-Final Office Action dated Nov. 9, 2018 in U.S. Appl. No. 15/636,307.
- USPTO; Final Office Action dated Mar. 6, 2019 in U.S. Appl. No. 15/636,307.
- USPTO; Non-Final Office Action dated Jul. 16, 2019 in U.S. Appl. No. 15/636,307.
- USPTO; Final Office Action dated Nov. 12, 2019 in U.S. Appl. No. 15/636,307.
- USPTO; Advisory Action dated Jan. 17, 2020 in U.S. Appl. No. 15/636,307.
- USPTO; Non-Final Office Action dated Mar. 11, 2020 in U.S. Appl. No. 15/636,307.
- USPTO; Notice of Allowance dated Jul. 18, 2018 in U.S. Appl. No. 15/640,239.
- USPTO; Notice of Allowance dated Aug. 30, 2018 in U.S. Appl. No. 15/640,239.
- USPTO; Non-Final Office Action dated Jun. 5, 2018 in U.S. Appl. No. 15/650,686.
- USPTO; Final Office Action dated Nov. 20, 2018 in U.S. Appl. No. 15/650,686.
- USPTO; Notice of Allowance dated Jun. 24, 2019 in U.S. Appl. No. 15/650,686.
- USPTO; Non-Final Office Action dated Sep. 21, 2018 in U.S. Appl. No. 15/659,631.
- USPTO; Notice of Allowance dated Feb. 21, 2019 in U.S. Appl. No. 15/659,631.
- USPTO; Non-Final Office Action dated Jul. 29, 2019 in U.S. Appl. No. 15/660,797.
- USPTO; Notice of Allowance dated Nov. 7, 2019 in U.S. Appl. No. 15/660,797.
- USPTO; Non-Final Office Action dated Aug. 9, 2018 in U.S. Appl. No. 15/660,805.
- USPTO; Non-Final Office Action dated Mar. 1, 2019 in U.S. Appl. No. 15/660,805.
- USPTO; Notice of Allowance dated Aug. 22, 2019 in U.S. Appl. No. 15/660,805.
- USPTO; Non-Final Office Action dated Aug. 27, 2018 in U.S. Appl. No. 15/662,107.
- USPTO; Notice of Allowance dated Feb. 21, 2019 in U.S. Appl. No. 15/662,107.
- USPTO; Non-Final Office Action dated Dec. 4, 2018 in U.S. Appl. No. 15/672,063.
- USPTO; Notice of Allowance dated Mar. 20, 2019 in U.S. Appl. No. 15/672,063.
- USPTO; Non-Final Office Action dated Oct. 10, 2019 in U.S. Appl. No. 15/672,096.
- USPTO; Final Office Action dated Mar. 27, 2020 in U.S. Appl. No. 15/672,096.
- USPTO; Non-Final Office Action dated Feb. 8, 2019 in U.S. Appl. No. 15/672,119.
- USPTO; Final Office Action dated Jul. 16, 2019 in U.S. Appl. No. 15/672,119.
- USPTO; Advisory Action dated Sep. 23, 2019 in U.S. Appl. No. 15/672,119.
- USPTO; Notice of Allowance dated Feb. 7, 2020 in U.S. Appl. No. 15/672,119.
- USPTO; Non-Final Office Action dated Jul. 27, 2018 in U.S. Appl. No. 15/673,110.
- USPTO; Notice of Allowance dated Jan. 9, 2019 in U.S. Appl. No. 15/673,110.
- USPTO; Non-Final Office Action dated Apr. 25, 2018 in U.S. Appl. No. 15/673,278.
- USPTO; Notice of Allowance dated May 6, 2019 in U.S. Appl. No. 15/673,278.
- USPTO; Non-Final Office Action dated Jan. 18, 2018 in U.S. Appl. No. 15/683,701.
- USPTO; Notice of Allowance dated Jan. 9, 2019 in U.S. Appl. No. 15/683,701.
- USPTO; Final Office Action dated Aug. 24, 2018 in U.S. Appl. No. 15/683,701.
- USPTO; Advisory Action dated Nov. 26, 2018 in U.S. Appl. No. 15/683,701.
- USPTO; Non-Final Office Action dated Dec. 18, 2018 in U.S. Appl. No. 15/690,017.

(56)

References Cited

OTHER PUBLICATIONS

- USPTO; Final Office Action dated Jul. 26, 2019 in U.S. Appl. No. 15/690,017.
- USPTO; Non-Final Office Action dated Nov. 20, 2019 in U.S. Appl. No. 15/690,017.
- USPTO; Non-Final Office Action dated Aug. 9, 2018 in U.S. Appl. No. 15/691,241.
- USPTO; Final Office Action dated Jan. 11, 2019 in U.S. Appl. No. 15/691,241.
- USPTO; Non-Final Office Action dated Mar. 19, 2019 in U.S. Appl. No. 15/691,241.
- USPTO; Final Office Action dated Jan. 24, 2020 in U.S. Appl. No. 15/691,241.
- USPTO; Non-Final Office Action dated Dec. 6, 2018 in U.S. Appl. No. 15/705,955.
- USPTO; Notice of Allowance dated Apr. 16, 2019 in U.S. Appl. No. 15/705,955.
- USPTO; Non-Final Office Action dated Feb. 11, 2019 in U.S. Appl. No. 15/707,786.
- USPTO; Final Office Action dated Aug. 12, 2019 in U.S. Appl. No. 15/707,786.
- USPTO; Notice of Allowance dated Nov. 7, 2019 in U.S. Appl. No. 15/707,786.
- USPTO; Non-Final Office Action dated Jun. 14, 2018 in U.S. Appl. No. 15/711,989.
- USPTO; Notice of Allowance dated Dec. 6, 2018 in U.S. Appl. No. 15/711,989.
- USPTO; Non-Final Office Action dated May 29, 2018 in U.S. Appl. No. 15/719,208.
- USPTO; Final Office Action dated Dec. 13, 2018 in U.S. Appl. No. 15/719,208.
- USPTO; Non-Final Office Action dated Jun. 25, 2019 in U.S. Appl. No. 15/719,208.
- USPTO; Notice of Allowance dated Jan. 29, 2020 in U.S. Appl. No. 15/719,208.
- USPTO; Non-Final Office Action dated Oct. 4, 2018 in U.S. Appl. No. 15/726,222.
- USPTO; Notice of Allowance dated Apr. 19, 2019 in U.S. Appl. No. 15/726,222.
- USPTO; Non-Final Office Action dated Apr. 19, 2018 in U.S. Appl. No. 15/726,959.
- USPTO; Final Office Action dated Nov. 14, 2018 in U.S. Appl. No. 15/726,959.
- USPTO; Non-Final Office Action dated Jul. 8, 2019 in U.S. Appl. No. 15/726,959.
- USPTO; Final Office Action dated Jan. 7, 2020 in U.S. Appl. No. 15/726,959.
- USPTO; Advisory Action dated Mar. 16, 2020 in U.S. Appl. No. 15/726,959.
- USPTO; Non-Final Office Action dated Apr. 3, 2020 in U.S. Appl. No. 15/726,959.
- USPTO; Non-Final Office Action dated Sep. 26, 2019 in U.S. Appl. No. 15/727,432.
- USPTO; Notice of Allowance dated Jan. 6, 2020 in U.S. Appl. No. 15/727,432.
- USPTO; Non-Final Office Action dated May 17, 2018 in U.S. Appl. No. 15/729,485.
- USPTO; Notice of Allowance dated Jan. 23, 2019 in U.S. Appl. No. 15/729,485.
- USPTO; Non-Final Office Action dated Nov. 28, 2018 in U.S. Appl. No. 15/795,056.
- USPTO; Final Office Action dated Apr. 19, 2019 in U.S. Appl. No. 15/795,056.
- USPTO; Final Office Action dated Jul. 31, 2019 in U.S. Appl. No. 15/795,056.
- USPTO; Non-Final Office Action dated Nov. 20, 2019 in U.S. Appl. No. 15/795,056.
- USPTO; Notice of Allowance dated Mar. 12, 2020 in U.S. Appl. No. 15/795,056.
- USPTO; Non-Final Office Action dated Jun. 26, 2018 in U.S. Appl. No. 15/796,593.
- USPTO; Final Office Action dated Feb. 21, 2019 in U.S. Appl. No. 15/796,593.
- USPTO; Non-Final Office Action dated Jun. 14, 2019 in U.S. Appl. No. 15/796,593.
- USPTO; Notice of Allowance dated Dec. 31, 2019 in U.S. Appl. No. 15/796,593.
- USPTO; Non-Final Office Action dated Dec. 26, 2017 in U.S. Appl. No. 15/798,120.
- USPTO; Notice of Allowance dated Jun. 13, 2018 in U.S. Appl. No. 15/798,120.
- USPTO; Non-Final Office Action dated Dec. 21, 2018 in U.S. Appl. No. 15/798,150.
- USPTO; Notice of Allowance dated May 14, 2019 in U.S. Appl. No. 15/798,150.
- USPTO; Non-Final Office Action dated Aug. 9, 2018 in U.S. Appl. No. 15/798,201.
- USPTO; Final Office Action dated Dec. 14, 2018 in U.S. Appl. No. 15/798,201.
- USPTO; Non-Final Office Action dated Oct. 2, 2019 in U.S. Appl. No. 15/798,201.
- USPTO; Final Office Action dated Mar. 19, 2020 in U.S. Appl. No. 15/798,201.
- USPTO; Non-Final Office Action dated Nov. 15, 2019 in U.S. Appl. No. 15/802,154.
- USPTO; Final Office Action dated Mar. 11, 2020 in U.S. Appl. No. 15/802,154.
- USPTO; Non-Final Office Action dated Jul. 2, 2018 in U.S. Appl. No. 15/815,483.
- USPTO; Final Office Action dated Mar. 7, 2019 in U.S. Appl. No. 15/815,483.
- USPTO; Non-Final Office Action dated Aug. 20, 2019 in U.S. Appl. No. 15/815,483.
- USPTO; Final Office Action dated Jan. 13, 2020 in U.S. Appl. No. 15/815,483.
- USPTO; Advisory Action dated Mar. 25, 2020 in U.S. Appl. No. 15/815,483.
- USPTO; Non-Final Office Action dated Sep. 26, 2018 in U.S. Appl. No. 15/832,188.
- USPTO; Notice of Allowance dated Dec. 5, 2017 in U.S. Appl. No. 15/832,188.
- USPTO; Non-Final Office Action dated Mar. 17, 2020 in U.S. Appl. No. 15/835,328.
- USPTO; Non-Final Office Action dated Feb. 20, 2020 in U.S. Appl. No. 15/835,352.
- USPTO; Non-Final Office Action dated Sep. 10, 2018 in U.S. Appl. No. 15/836,547.
- USPTO; Non-Final Office Action dated Mar. 13, 2019 in U.S. Appl. No. 15/836,547.
- USPTO; Notice of Allowance dated Aug. 16, 2019 in U.S. Appl. No. 15/836,547.
- USPTO; Non-Final Office Action dated Jul. 31, 2019 in U.S. Appl. No. 15/860,564.
- USPTO; Final Office Action dated Nov. 13, 2019 in U.S. Appl. No. 15/860,564.
- USPTO; Advisory Action dated Jan. 21, 2020 in U.S. Appl. No. 15/860,564.
- USPTO; Non-Final Office Action dated Mar. 30, 2020 in U.S. Appl. No. 15/860,564.
- USPTO; Non-Final Office Action dated Mar. 20, 2020 in U.S. Appl. No. 15/861,418.
- USPTO; Non-Final Office Action dated Jul. 23, 2018 in U.S. Appl. No. 15/863,340.
- USPTO; Notice of Allowance dated Dec. 10, 2018 in U.S. Appl. No. 15/863,340.
- USPTO; Non-Final Office Action dated Jan. 11, 2019 in U.S. Appl. No. 15/879,209.
- USPTO; Non-Final Office Action dated Jan. 22, 2019 in U.S. Appl. No. 15/879,209.
- USPTO; Final Office Action dated Aug. 21, 2019 in U.S. Appl. No. 15/879,209.

(56)

References Cited

OTHER PUBLICATIONS

- USPTO; Advisory Action dated Nov. 5, 2019 in U.S. Appl. No. 15/879,209.
- USPTO; Notice of Allowance dated Jan. 16, 2020 in U.S. Appl. No. 15/879,209.
- USPTO; Non-Final Office Action dated Apr. 17, 2019 in U.S. Appl. No. 15/886,225.
- USPTO; Notice of Allowance dated Sep. 23, 2019 in U.S. Appl. No. 15/886,225.
- USPTO; Non-Final Office Action dated Nov. 15, 2018 in U.S. Appl. No. 15/890,037.
- USPTO; Final Office Action dated May 2, 2019 in U.S. Appl. No. 15/890,037.
- USPTO; Non-Final Office Action dated Oct. 24, 2019 in U.S. Appl. No. 15/890,037.
- USPTO; Final Office Action dated Feb. 26, 2020 in U.S. Appl. No. 15/890,037.
- USPTO; Notice of Allowance dated Feb. 8, 2019 in U.S. Appl. No. 15/892,756.
- USPTO; Non-Final Office Action dated Apr. 24, 2019 in U.S. Appl. No. 15/896,986.
- USPTO; Final Office Action dated Nov. 19, 2019 in U.S. Appl. No. 15/896,986.
- USPTO; Advisory Action dated Feb. 7, 2020 in U.S. Appl. No. 15/896,986.
- USPTO; Non-Final Office Action dated Mar. 24, 2020 in U.S. Appl. No. 15/896,986.
- USPTO; Non-Final Office Action dated Sep. 19, 2019 in U.S. Appl. No. 15/897,578.
- USPTO; Notice of Allowance dated Mar. 27, 2020 in U.S. Appl. No. 15/897,578.
- USPTO; Non-Final Office Action dated May 30, 2019 in U.S. Appl. No. 15/900,425.
- USPTO; Notice of Allowance dated Dec. 17, 2019 in U.S. Appl. No. 15/900,425.
- USPTO; Non-Final Office Action dated Mar. 8, 2019 in U.S. Appl. No. 15/917,224.
- USPTO; Final Office Action dated Aug. 28, 2019 in U.S. Appl. No. 15/917,224.
- USPTO; Advisory Action dated Nov. 27, 2019 in U.S. Appl. No. 15/917,224.
- USPTO; Non-Final Office Action dated Feb. 8, 2019 in U.S. Appl. No. 15/917,262.
- USPTO; Final Office Action dated Jun. 14, 2019 in U.S. Appl. No. 15/917,262.
- USPTO; Notice of Allowance dated Aug. 30, 2019 in U.S. Appl. No. 15/917,262.
- USPTO; Non-Final Office Action dated Dec. 23, 2019 in U.S. Appl. No. 15/923,834.
- USPTO; Final Office Action dated Mar. 12, 2020 in U.S. Appl. No. 15/923,834.
- USPTO; Non-Final Office Action dated May 8, 2019 in U.S. Appl. No. 15/925,532.
- USPTO; Final Office Action dated Nov. 27, 2019 in U.S. Appl. No. 15/925,532.
- USPTO; Non-Final Office Action dated Jul. 22, 2019 in U.S. Appl. No. 15/940,759.
- USPTO; Final Office Action dated Feb. 19, 2020 in U.S. Appl. No. 15/940,759.
- USPTO; Non-Final Office Action dated Mar. 29, 2019 in U.S. Appl. No. 15/940,801.
- USPTO; Notice of Allowance dated Aug. 26, 2019 in U.S. Appl. No. 15/940,801.
- USPTO; Non-Final Rejection dated Nov. 29, 2019 in U.S. Appl. No. 15/949,990.
- USPTO; Notice of Allowance dated Mar. 12, 2020 in U.S. Appl. No. 15/949,990.
- USPTO; Notice of Allowance dated May 31, 2019 in U.S. Appl. No. 15/957,565.
- USPTO; Non-Final Office Action dated Jan. 31, 2020 in U.S. Appl. No. 15/962,980.
- USPTO; Non-Final Office Action dated Apr. 2, 2020 in U.S. Appl. No. 15/974,948.
- USPTO; Non-Final Office Action dated Jan. 16, 2020 in U.S. Appl. No. 15/985,261.
- USPTO; Notice of Allowance dated Apr. 3, 2020 in U.S. Appl. No. 15/985,261.
- USPTO; Non-Final Office Action dated Apr. 19, 2019 in U.S. Appl. No. 15/985,298.
- USPTO; Notice of Allowance dated Aug. 22, 2019 in U.S. Appl. No. 15/985,298.
- USPTO; Non-Final Office Action dated Feb. 21, 2019 in U.S. Appl. No. 15/987,755.
- USPTO; Notice of Allowance dated Jul. 31, 2019 in U.S. Appl. No. 15/987,755.
- USPTO; Non-Final Office Action dated Apr. 1, 2020 in U.S. Appl. No. 15/997,445.
- USPTO; Non-Final Office Action dated Mar. 3, 2020 in U.S. Appl. No. 16/000,109.
- USPTO; Non-Final Office Action dated Jul. 29, 2019 in U.S. Appl. No. 16/000,125.
- USPTO; Final Office Action dated Jan. 13, 2020 in U.S. Appl. No. 16/000,125.
- USPTO; Advisory Action dated Apr. 3, 2020 in U.S. Appl. No. 16/000,125.
- USPTO; Non-Final Office Action dated Jul. 16, 2019 in U.S. Appl. No. 16/014,981.
- USPTO; Non-Final Office Action dated Jan. 16, 2020 in U.S. Appl. No. 16/014,981.
- USPTO; Non-Final Office Action dated Jan. 24, 2019 in U.S. Appl. No. 16/018,692.
- USPTO; Final Office Action dated Aug. 23, 2019 in U.S. Appl. No. 16/018,692.
- USPTO; Non-Final Office Action dated Dec. 11, 2019 in U.S. Appl. No. 16/018,692.
- USPTO; Notice of Allowance dated Jan. 30, 2020 in U.S. Appl. No. 16/018,692.
- USPTO; Non-Final Office Action dated Aug. 7, 2019 in U.S. Appl. No. 16/024,390.
- USPTO; Notice of Allowance dated Nov. 26, 2019 in U.S. Appl. No. 16/024,390.
- USPTO; Notice of Allowance dated Apr. 9, 2019 in U.S. Appl. No. 16/026,711.
- USPTO; Non-Final Office Action dated Mar. 4, 2020 in U.S. Appl. No. 16/036,692.
- USPTO; Non-Final Office Action dated Apr. 25, 2019 in U.S. Appl. No. 16/038,024.
- USPTO; Final Office Action dated Nov. 29, 2019 in U.S. Appl. No. 16/038,024.
- USPTO; Advisory Action dated Feb. 28, 2020 in U.S. Appl. No. 16/038,024.
- USPTO; Notice of Allowance dated Mar. 23, 2020 in U.S. Appl. No. 16/038,024.
- USPTO; Non-Final Office Action dated Jul. 25, 2019 in U.S. Appl. No. 16/039,867.
- USPTO; Final Office Action dated Jan. 28, 2020 in U.S. Appl. No. 16/039,867.
- USPTO; Notice of Allowance dated Apr. 3, 2020 in U.S. Appl. No. 16/039,867.
- USPTO; Notice of Allowance dated Jul. 10, 2019 in U.S. Appl. No. 16/046,218.
- USPTO; Non-Final Office Action dated Feb. 20, 2020 in U.S. Appl. No. 16/105,745.
- USPTO; Non-Final Office Action dated Feb. 24, 2020 in U.S. Appl. No. 16/105,761.
- USPTO; Non-Final Office Action dated Mar. 19, 2020 in U.S. Appl. No. 16/105,802.
- USPTO; Non-Final Office Action dated Mar. 16, 2020 in U.S. Appl. No. 16/116,708.
- USPTO; Non-Final Office Action dated Feb. 6, 2020 in U.S. Appl. No. 16/117,530.

(56)

References Cited

OTHER PUBLICATIONS

- USPTO; Non-Final Office Action dated Jan. 6, 2020 in U.S. Appl. No. 16/132,142.
- USPTO; Non-Final Office Action dated Feb. 28, 2020 in U.S. Appl. No. 16/137,974.
- USPTO; Non-Final Office Action dated Apr. 2, 2019 in U.S. Appl. No. 16/147,047.
- USPTO; Final Office Action dated Sep. 25, 2019 in U.S. Appl. No. 16/147,047.
- USPTO; Notice of Allowance dated Jan. 3, 2020 in U.S. Appl. No. 16/147,047.
- USPTO; Non-Final Office Action dated Nov. 5, 2019 in U.S. Appl. No. 16/152,260.
- USPTO; Non-Final Office Action dated Aug. 6, 2019 in U.S. Appl. No. 16/158,077.
- USPTO; Final Office Action dated Mar. 2, 2020 in U.S. Appl. No. 16/158,077.
- USPTO; Non-Final Office Action dated Aug. 29, 2019 in U.S. Appl. No. 16/161,744.
- USPTO; Final Office Action dated Mar. 17, 2020 in U.S. Appl. No. 16/161,744.
- USPTO; Non-Final Office Action dated Aug. 16, 2019 in U.S. Appl. No. 16/167,225.
- USPTO; Final Office Action dated Dec. 16, 2019 in U.S. Appl. No. 16/167,225.
- USPTO; Notice of Allowance dated Mar. 5, 2020 in U.S. Appl. No. 16/167,225.
- USPTO; Notice of Allowance dated Apr. 17, 2019 in U.S. Appl. No. 16/171,098.
- USPTO; Notice of Allowance dated May 1, 2019 in U.S. Appl. No. 16/171,098.
- USPTO; Non-Final Office Action dated Apr. 2, 2019 in U.S. Appl. No. 16/188,690.
- USPTO; Final Office Action dated Sep. 26, 2019 in U.S. Appl. No. 16/188,690.
- USPTO; Notice of Allowance dated Dec. 16, 2019 in U.S. Appl. No. 16/188,690.
- USPTO; Notice of Allowance dated Oct. 3, 2019 in U.S. Appl. No. 16/200,100.
- USPTO; Non-Final Office Action dated Aug. 19, 2019 in U.S. Appl. No. 16/208,062.
- USPTO; Notice of Allowance dated Jan. 28, 2020 in U.S. Appl. No. 16/208,062.
- USPTO; Non-Final Office Action dated Sep. 16, 2019 in U.S. Appl. No. 16/213,702.
- USPTO; Notice of Allowance dated Dec. 9, 2019 in U.S. Appl. No. 16/213,702.
- USPTO; Non-Final Office Action dated Jan. 8, 2020 in U.S. Appl. No. 16/219,555.
- USPTO; Non-Final Office Action dated Feb. 19, 2020 in U.S. Appl. No. 16/242,829.
- USPTO; Non-Final Office Action dated Jan. 30, 2020 in U.S. Appl. No. 16/245,006.
- USPTO; Non-Final Office Action dated Sep. 24, 2019 in U.S. Appl. No. 16/251,534.
- USPTO; Final Office Action dated Jan. 10, 2020 in U.S. Appl. No. 16/251,534.
- USPTO; Advisory Action dated Apr. 3, 2020 in U.S. Appl. No. 16/251,534.
- USPTO; Non-Final Office Action dated Dec. 18, 2019 in U.S. Appl. No. 16/280,964.
- USPTO; Non-Final Office Action dated Jan. 9, 2020 in U.S. Appl. No. 16/317,774.
- USPTO; Notice of Allowance dated Apr. 15, 2020 in U.S. Appl. No. 16/317,774.
- USPTO; Non-Final Office Action dated Mar. 2, 2020 in U.S. Appl. No. 16/356,394.
- USPTO; Notice of Allowance dated Jun. 13, 2019 in U.S. Appl. No. 16/396,475.
- USPTO; Non-Final Office Action dated Dec. 26, 2019 in U.S. Appl. No. 16/417,938.
- USPTO; Notice of Allowance dated Mar. 30, 2020 in U.S. Appl. No. 16/417,938.
- USPTO; Non-Final Office Action dated Dec. 31, 2019 in U.S. Appl. No. 16/427,288.
- USPTO; Non-Final Office Action dated Dec. 31, 2019 in U.S. Appl. No. 16/455,406.
- USPTO; Final Office Action dated Jan. 10, 2020 in U.S. Appl. No. 16/674,894.
- USPTO; Notice of Allowance dated May 14, 2012 in U.S. Appl. No. 29/411,637.
- USPTO; Notice of Allowance dated Oct. 2, 2013 in U.S. Appl. No. 29/412,887.
- USPTO; Non-Final Office Action dated Mar. 16, 2015 in U.S. Appl. No. 29/447,298.
- USPTO; Notice of Allowance dated Jul. 6, 2015 in U.S. Appl. No. 29/447,298.
- USPTO; Notice of Allowance dated Dec. 19, 2013 in U.S. Appl. No. 29/448,094.
- USPTO; Notice of Allowance dated Nov. 26, 2014 in U.S. Appl. No. 29/481,301.
- USPTO; Notice of Allowance dated Feb. 17, 2015 in U.S. Appl. No. 29/481,308.
- USPTO; Notice of Allowance dated Jan. 12, 2015 in U.S. Appl. No. 29/481,312.
- USPTO; Notice of Allowance dated Apr. 30, 2015 in U.S. Appl. No. 29/481,315.
- USPTO; Notice of Allowance dated May 11, 2015 in U.S. Appl. No. 29/511,011.
- USPTO; Notice of Allowance dated May 11, 2015 in U.S. Appl. No. 29/514,153.
- USPTO; Notice of Allowance dated Dec. 14, 2015 in U.S. Appl. No. 29/514,264.
- USPTO; Notice of Allowance dated Jun. 16, 2017 in U.S. Appl. No. 29/570,711.
- USPTO; Non-Final Office Action dated Apr. 16, 2019 in U.S. Appl. No. 29/604,101.
- USPTO; Notice of Allowance dated Oct. 30, 2019 in U.S. Appl. No. 29/604,101.
- USPTO; Notice of Allowance dated Jun. 26, 2018 in U.S. Appl. No. 29/604,288.
- USPTO; Ex Parte Quayle Action dated Dec. 17, 2019 in U.S. Appl. No. 29/615,000.
- USPTO; Non-Final Office Action dated Aug. 21, 2019 in U.S. Appl. No. 29/634,768.
- USPTO; Notice of Allowance dated Jan. 23, 2020 in U.S. Appl. No. 29/634,768.
- USPTO; Non-Final Office Action dated Feb. 20, 2019 in U.S. Appl. No. 29/646,377.
- USPTO; Final Office Action dated Jul. 15, 2019 in U.S. Appl. No. 29/646,377.
- USPTO; Notice of Allowance dated Nov. 14, 2019 in U.S. Appl. No. 29/646,377.
- WIPO; International Search Report and Written Opinion dated Nov. 16, 2017 in Application No. PCT/IB2017/001015.
- WIPO; International Search Report and Written Opinion dated Nov. 13, 2017 in Application No. PCT/IB2017/001050.
- WIPO; International Search Report and Written Opinion dated Nov. 30, 2017 in Application No. PCT/IB2017/001070.
- WIPO; International Search Report and Written Opinion dated Jan. 25, 2018 in Application No. PCT/IB2017/001262.
- WIPO; International Search Report and Written Opinion dated Sep. 14, 2018 in Application No. PCT/IB2017/001640.
- WIPO; International Search Report and Written Opinion dated Jun. 1, 2018 in Application No. PCT/IB2017/001644.
- WIPO; International Search Report and Written Opinion dated Nov. 6, 2018 in Application No. PCT/IB2017/001652.
- WIPO; International Search Report and Written Opinion dated Jun. 1, 2018 in Application No. PCT/IB2017/001656.
- WIPO; International Search Report and Written Opinion dated Jan. 25, 2019 in Application No. PCT/IB2018/000192.

(56)

References Cited

OTHER PUBLICATIONS

- WIPO; International Search Report and Written Opinion dated Jul. 9, 2018 in Application No. PCT/IB2018/000419.
- WIPO; International Search Report and Written Opinion dated Jan. 4, 2019 in Application No. PCT/IB2018/000936.
- WIPO; International Search Report and Written Opinion dated Dec. 20, 2018 in Application No. PCT/IB2018/001003.
- WIPO; International Search Report and Written Opinion dated Dec. 20, 2018 in Application No. PCT/IB2018/001022.
- WIPO; International Search Report and Written Opinion dated Jun. 28, 2019 in Application No. PCT/IB2019/000084.
- WIPO; International Search Report and Written Opinion dated Nov. 19, 2019 in Application No. PCT/IB2019/000127.
- WIPO; International Search Report and Written Opinion dated Jan. 10, 2020 in Application No. PCT/IB2019/000729.
- WIPO; International Search Report and Written Opinion dated Dec. 20, 2019 in Application No. PCT/IB2019/000805.
- WIPO; International Search Report and Written Opinion dated Dec. 20, 2019 in Application No. PCT/IB2019/000817.
- WIPO; International Search Report and Written Opinion dated May 23, 2019 in Application No. PCT/IB2019/050974.
- WIPO; International Search Report and Written Opinion dated Apr. 17, 2019 in Application No. PCT/NL2018/050787.
- WIPO; International Search Report and Written Opinion dated Apr. 29, 2019 in Application No. PCT/NL2018/050791.
- WIPO; International Preliminary Report on Patentability dated Nov. 24, 2009 and International Search Report dated Jul. 31, 2008 in Application No. PCT/US2008/063919.
- WIPO; International Preliminary Report on Patentability dated Feb. 24, 2010 in Application No. PCT/US2008/074063.
- WIPO; International Preliminary Report on Patentability dated Nov. 26, 2009 in Application No. PCT/US2009/043454.
- WIPO; International Preliminary Report on Patentability dated Jun. 14, 2011 in Application No. PCT/US2009/066377.
- WIPO; International Search report and Written Opinion dated Nov. 12, 2010 in Application No. PCT/US2010/030126.
- WIPO; International Preliminary Report on Patentability dated Oct. 11, 2011 Application No. PCT/US2010/030126.
- WIPO; International Preliminary Report on Patentability dated Nov. 9, 2011 in Application No. PCT/US2010/033244.
- WIPO; International Preliminary Report on Patentability dated Nov. 9, 2011 in Application No. PCT/US2010/033248.
- WIPO; International Preliminary Report on Patentability dated Nov. 9, 2011 in Application No. PCT/US2010/033252.
- WIPO; International Search report and Written Opinion dated Jan. 20, 2011 in Application No. PCT/US2010/045368.
- WIPO; International Search report and Written Opinion dated Feb. 6, 2013 in Application No. PCT/US2012/065343.
- WIPO; International Search report and Written Opinion dated Feb. 13, 2013 in Application No. PCT/US2012/065347.
- Alen, "Atomic layer deposition of TaN, NbN and MoN films for Cu Metallizations," University of Helsinki Finland, 72 pages, (2005).
- Arita et al. "Electrical and optical properties of germanium-doped zinc oxide thin films" *Materials Transactions*, vol. 45, No. 11, pp. 3180-3183 (2004).
- Arnold et al., "Novel single-layer vanadium sulphide phases" *2D Materials*, 5, 045009, 11 pages.
- Athavale et al., "Realization of Atomic Layer Etching of Silicon", *Journal of Vacuum Science and Technology B*, vol. 14, pp. 3702-3705 (1996).
- Bark et al. "Large-area niobium disulfide thin films as transparent electrodes for devices based on two-dimensional materials," *Nanoscale*, published online, 7 pages. (2012).
- Barreca et al. "Cobalt oxide nanomaterials by vapor phase synthesis for fast and reversible lithium storage" *J Phys Chem C*, 114, 10054-10060 (2010).
- Basuvalingam et al. "NS-WeA6—Low Temperature ALD for Phase-controlled Synthesis of 2D Transition Metal (M=Ti, Nb) di-(MX₂) and Tri-(MX₃) Sulfides," AVS 19th International Conference on Atomic Layer Deposition (ALD 2019)), Jul. 22, 2019, Abstract, 1 page (2019).
- Bearzotti, et al., "Fast Humidity Response of a Metal Halide-Doped Novel Polymer," *Sensors and Actuators B*, 7, pp. 451-454, (1992).
- Becker et al., "Atomic Layer Deposition of Insulating Hafnium and Zirconium Nitrides," *Chem. Mater.*, 16, 3497-3501 (2004).
- Beynet et al. "Low temperature plasma-enhanced ALD enables cost-effective spacer defined double patterning," *Proceedings of SPIE*, 7520, (2009).
- Bhatnagar et al., "Copper Interconnect Advances to Meet Moore's Law Milestones," *Solid State Technology*, 52, 10 (2009).
- Boscher et al., "Atmosphere Pressure Chemical Vapour Deposition of NbSe₂ Thin Films on Glass" *Eur. J. Inorg. Chem.*, pp. 1255-1259 (2006).
- Buriak, "Organometallic Chemistry on Silicon and Germanium Surfaces," *Chemical Reviews*, 102, 5 (2002).
- Cahiez et al. "Cobalt-Catalyzed cross coupling reaction between functionalized primary and secondary alkyl halides and aliphatic grignard reagents" *Adv. Synth. Catal*, 350, 1484-1488 (2008).
- Cant et al., "Chemisorption Sites on Porous Silica Glass and on Mixed-Oxide Catalysis," *Can. J. Chem.* 46, 1373 (1968).
- Carmalt et al., "Chemical Vapor Deposition of Niobium Disulfide Thin Films" *Eur. J. Inorg. Chem.*, pp. 4470-4476 (2004).
- Casey et al. "Chemical Vapor Deposition of Mo onto Si" *J. Electrochem. Soc.: Solid State Science*, 114 (2), pp. 201-204 (1967).
- Chang et al. "Small-Subthreshold-Swing and Low-Voltage Flexible Organic Thin-Film Transistors Which Use HfLaO as the Gate Dielectric," *IEEE Electron Device Letters*, Feb. 2009, pp. 133-135; vol. 30, No. 2; IEEE Electron Device Society.
- Chatterjee et al., "Sub-100nm Gate Length Metal Gate NMOS Transistors Fabricated by a Replacement by a Replacement Gate Process," *IEEE Semiconductor Process and Device Center*, 821-824 (1997).
- Chen et al., "A Self-Aligned Airgap Interconnect Scheme," *IEEE International Interconnect Technology Conference*, vol. 1-3, 146-148 (2009).
- Chen et al., "Develop Gap-fill Process of Shallow Trench Isolation in 450mm Wafer by Advanced Flowable CVD Technology for Sub-20nm Node," 2016 27th Annual Semi Advanced Semiconductor.
- Cheng et al., "Effect of carrier gas on the structure and electric properties of low dielectric constant SiCOH film using trimethylsilane prepared by plasma enhanced chemical vapor deposition," *Thin Solid Films* vol. 469-470, pp. 178-183 (2004).
- Choi et al., "Improvement of Silicon Direct Bonding using Surfaces Activated by Hydrogen Plasma Treatment," *Journal of the Korean Physical Society*, 37, 6, 878-881 (2000).
- Choi et al., "Low Temperature Formation of Silicon Oxide Thin Films by Atomic Layer Deposition Using NH₃/O₂ Plasma," *ECS Solid State Letters*, 2(12) P114-P116 (2013).
- Coates, "Process Analytical Technology: Spectroscopic Tools and Implementation Strategies for the Chemical and Pharmaceutical Industries." Blackwell Publishing Ltd, 91-132, (2005).
- Conroy et al., "The Preparation and Properties of Single Crystals of the 1S and 2S Polymorphs of Tantalum Disulfide" *J. Solid State Chemistry*, 4, pp. 345-350 (1972).
- Crowell, "Chemical methods of thin film deposition: Chemical vapor deposition, atomic layer deposition, and related technologies," *Journal of Vacuum Science & Technology A* 21.5, (2003): S88-S95.
- Cui et al., "Impact of Reductive N₂/H₂ Plasma on Porous Low-Dielectric Constant SiCOH Thin Films," *Journal of Applied Physics* 97, 113302, 1-8 (2005).
- De Silva et al., "Inorganic Hardmask Development For Extreme Ultraviolet Patterning," *Journal of Micro/Nanolithography, MEMS, and MOEMS* 18(1) (2018).
- Dingemans et al., "Comparison Between Aluminum Oxide Surface Passivation Films Deposited with Thermal Aid," *Plasma Aid and Pevcd*, 35th IEEE PVCS, Jun. (2010).
- Drummond et al., "Hydrophobic Radiofrequency Plasma-Deposited Polymer Films: Dielectric Properties and Surface Forces," *Colloids and Surfaces A*, 129-130, 117-129 (2006).

(56)

References Cited

OTHER PUBLICATIONS

- Duffey et al., "Raman Scattering from 1T-TaS₂" *Solid State Communications* 20, pp. 617-621 (1976).
- Easley et al., "Thermal Isolation of Microchip Reaction Chambers for Rapid Non-Contact DNA Amplification," *J. Micromech. Microeng.* 17, 1758-1766 (2007).
- Elam et al., "New Insights into Sequential Infiltration Synthesis", *ECS Transactions*, vol. 69, pp. 147-157 (2015).
- Elers et al. "Film Uniformity in Atomic Layer Deposition," *Chemical Vapor Deposition*, 12, pp. 13-24 (2006).
- Ellis et al. "Nitrous Oxide (N₂O) Processing for Silicon Oxynitride Gate Dielectrics." *IBM Journal of Research and Development*. 1999. 43[3]. pp. 287-300. (1999).
- "Fiji F200 200mm Thermal/Plasma ALD Systems: Installation and Use Manual." CAW-02635 Rev. 0.6 (Mar. 13, 2012). Cambridge NanoTech Inc. pp. 1-164 (2012).
- Fu et al., "Controlled Synthesis of Atomically Thin 1T-TaS₂ for Tunable Charge Density Wave Phase Transitions" *Chem. Mater.* 28, pp. 7613-7618 (2016).
- Ge et al., "Carbon Nanotube-Based Synthetic Gecko Tapes," *Department of Polymer Science, PNAS*, 10792-10795 (2007).
- Ge et al. "Large-scale synthesis of NbS₂ nanosheets with controlled orientation on graphene by ambient pressure CVD," *Nanoscale*, vol. 5, 5773-5778 (2013).
- George et al., "Atomic Layer Deposition: An Overview," *Chem. Rev.* 110, 111-131 (2010).
- Gesheva et al. "Composition and Microstructure of Black Molybdenum Photothermal Converter Layers Deposited by the Pyrolytic Hydrogen Reduction of MoO₂Cl₂" *Thin Solid Films*, 79, pp. 39-49 (1981).
- Gole et al. "Preparation of Nickel Sulfide Thin Films and Nanocrystallites Using Nickel Furfuraldehyde Thiosemicarbazone as Single-source Precursor," *Advanced Materials Research*, vols. 383-390, pp. 3828-3834 (2012).
- Gordon et al. "A Kinetic Model for Step Coverage by Atomic Layer Deposition in Narrow Holes or Trenches." *Chemical Vapor Deposition*. 9 [2]. pp. 73-78 (2003).
- Grill et al., "The Effect of Plasma Chemistry on the Damage Induced Porous SiCOH Dielectrics," *IBM Research Division, RC23683 (W0508-008), Materials Science*, 1-19 (2005).
- Guan et al., "Voltage gated ion and molecule transport in engineered nanochannels: theory, fabrication and applications," *Nanotechnology* 25 (2014) 122001.
- Gupta et al., "Charge carrier transport and electroluminescence in atomic layer deposited poly-GaN/c-Si heterojunction diodes," *Journal of Applied Physics*, 124, 084503 (2018).
- Gupta et al., "Conversion of Metal Carbides to Carbide Derived Carbon by Reactive Ion Etching in Halogen Gas," *Proceedings of SPIE—The International Society for Optical Engineering and Nanotechnologies for Space Applications*, ISSN: 0277-786X (2006).
- Habib et al. "Atmospheric oxygen plasma activation of silicon (100) surfaces," *American Vacuum Society*, 28(3), pp. 476-485 (2010).
- Hamalainen et al., "Atomic Layer Deposition of Rhenium Disulfide," *Adv. Mater.* 30.24, 6 pages (2018).
- Han et al., "van der Waals Metallic Transition Metal Dichalcogenides" *Chem. Rev.* 118, pp. 6297-6336 (2018).
- Hansen. "A Primer on Vacuum Pressure Measurement." *Vacuum Technology & Coating*. Jun. 2009. pp. 36-42 (2009).
- Hansen. "Speed, Pressure and Throughput: Part 1 System Diagnostics." *Vacuum Technology & Coating*. Sep. 2011. pp. 14-17 (2011).
- Hansen. "Speed, Pressure and Throughput: Part 2 Managing Gas Flow in High Vacuum Systems." *Vacuum Technology & Coating*. Oct. 2011. pp. 19-22 (2011).
- Hansen. "Speed, Pressure and Throughput: Part 3 Automating the Pressure Control Process." *Vacuum Technology & Coating*. Nov. 2011. pp. 22-25 (2011).
- Hansen. "Speed, Pressure and Throughput: Part 4 Outgassing and Base Pressure." *Vacuum Technology & Coating*. Dec. 2011. pp. 22-25 (2011).
- Hansen. "Speed, Pressure and Throughput: Part 5 Leaks and Gas Flow in Leak Detection." *Vacuum Technology & Coating*. Jan. 2012. pp. 18-21 (2011).
- Hargreaves et al., "New Fluorides and Oxyfluorides of Rhenium," *J. Chem. Soc.*, pp. 1099-1103 (1960).
- Harrison et al., "Poly-gate Replacement Through Contact Hole (PRETCH): A New Method for High-K/ Metal Gate and Multi-Oxide Implementation on Chip," *IEEE* (2004).
- Hayashi et al. "Spectroscopic properties of nitrogen doped hydrogenated amorphous carbon films grown by radio frequency plasma-enhanced chemical vapor deposition," *Journal of Applied Physics*. vol. 89, No. 12, pp. 7924-7931 (2001).
- Heo et al., "Structural Characterization of Nanoporous Low-Dielectric Constant SiCOH Films Using Organosilane Precursors," *NSTI-Nanotech*, vol. 4, 122-123 (2007).
- Henke et al., "X-Ray Interactions: Photo absorption, Scattering, Transmission, and Reflection at E=50-30,000 eV, Z=1-92," *Atomic Data and Nuclear Data Tables*, 54, 181-342 (1993).
- Heyne et al., "The conversion mechanism of amorphous silicon to stoichiometric WS₂" *J. Materials Chemistry C*, 6, pp. 4122-4130 (2018).
- Hossain et al., "Recent Advances in Two-Dimensional Materials with Charge Density Waves: Synthesis, Characterization and Applications" *Crystals* 7, 298, 19 pages (2017).
- Hudis, "Surface Crosslinking of Polyethylene Using a Hydrogen Glow Discharge," *J. Appl. Polym. Sci.*, 16 (1972) 2397.
- Johansson et al. "Towards absolute asymmetric synthesis. Synthesis and crystal structure of stereochemically labile MCl₂ (M=CO, Ni, Cu, Zn) complexes with diamine ligands," *Inorganica Chimica Acta* 358, pp. 3293-3302 (2005).
- Jones et al., "Growth of Aluminum Films by Low Pressure Chemical Vapour Deposition Using Tertiarybutylaluminium," *Journal of Crystal Growth* 135, pp. 285-289, Elsevier Science B.V. (1994).
- Jones et al., "Recent Developments in Metalorganic Precursors for Metalorganic Chemical Vapour Deposition," *Journal of Crystal Growth* 146, pp. 503-510, Elsevier Science B.V. (1995).
- Jung et al., "Double Patterning of Contact Array with Carbon Polymer," *Proc. Of SPIE*, 6924, 69240C, 1-10 (2008).
- Kern et al., "Chemically Vapor-Deposited Borophosphosilicate Glasses for Silicon Device Applications" *RCE Review*, 43, 3, pp. 423-457 (1982).
- Kerrigan et al. "Low Temperature, Selective Atomic Layer Deposition of Cobalt Metal Films Using Bis(1,4-di-tert-butyl-1,3-diazadienyl)cobalt and Alkylamine Precursors," *Chem. Materials*, 29, pp. 7458-7466 (2017).
- Khandelwal et al. "Low-temperature Ar/N₂ remote plasma nitridation of SiO₂ thin films," *J. Vacuum Science & Technology A*, 20(6), pp. 1989-1996 (2002).
- Kim et al., "Passivation Effect on Low-k S/OC Dielectrics by H₂ Plasma Treatment," *Journal of the Korean Physical Society*, 40, 1, 94-98 (2002).
- Kim et al., "Characteristics of Low Temperature High Quality Silicon Oxide by Plasma Enhanced Atomic Layer Deposition with In-Situ Plasma Densification Process," *The Electrochemical Society, ECS Transactions*, College of Information and Communication Engineering, Sungkyunkwan University, 53(1), 321-329 (2013).
- Kim et al., "Novel Flowable CVD Process Technology for sub-20nm Interlayer Dielectrics," *IEEE. International Interconnect Technology Conference (IITC 2012)*, San Jose, California, USA, Jun. 4-6, 2012, pp. 1-3 (2012).
- King, Plasma. Enhanced Atomic Layer Deposition of SiN_x: H and SiO₂, *J. Vac. Sci. Technol.*, A29(4) (2011).
- Klug et al., "Atomic Layer Deposition of Amorphous Niobium Carbide-Based Thin Film Superconductors," *The Journal of Physical Chemistry C*, vol. 115, pp. 25063-25071, (2011).
- Kobayshi, et al., "Temperature Dependence of SiO₂ Film Growth with Plasma-Enhanced Atomic Layer Deposition," regarding Thin Solid Films, published by Elsevier in the *International Journal on the Science and Technology of Condensed Matter*, in vol. 520, No. 11, 3994-3998 (2012).
- Kogelschatz et al. "Ozone Generation from Oxygen and Air: Discharge Physics And Reaction Mechanisms" *Ozone Science & Engineering*, 10, pp. 367-378 (1998).

(56)

References Cited

OTHER PUBLICATIONS

- Koo et al., "Characteristics of Al₂O₃ Thin Films Deposited Using Dimethylaluminum Isopropoxide and Trimethylaluminum Precursors by the Plasma-Enhanced Atomic-Layer Deposition Method," *Journal of Physical Society*, 48, 1, 131-136 (2006).
- Koutsokeras et al., "Texture and Microstructure Evolution in Single-Phase Ti_xTal-xN Alloys of Rocksalt Structure," *Journal of Applied Physics*, 110, pp. 043535-1-043535-6, (2011).
- Knoops et al., "Atomic Layer Deposition of Silicon Nitride from Bis(tert-butyloamino) silane and N₂ Plasma," *Applied Materials & Interfaces*, American Chemical Society, A-E (2015).
- Krenek et al., "IR Laser CVD of Nanodisperse Ge-Si-Sn Alloys Obtained by Dielectric Breakdown of GeH₄/SiH₄/SnH₄ Mixtures," *NanoCon 2014*, Nov. 5-7, Brno, Czech Republic, EU.
- Kucheyev et al., "Mechanisms of Atomic Layer Deposition on Substrates with Ultrahigh Aspect Ratios," *Langmuir*, 24 [3], pp. 943-948 (2008).
- Kukli et al., "Influence of atomic layer deposition parameters on the phase content of Ta₂O₅ films" *J. Crystal Growth*, 212, pp. 459-468 (2000).
- Kukli et al., "Properties of hafnium oxide films grown by atomic layer deposition from hafnium tetraiodide and oxygen". *Journal of Applied Physics*, vol. 92, No. 10, Nov. 15, 2002, pp. 5698-5703 (2002).
- Kukli et al., "Properties of tantalum oxide thin films grown by atomic layer deposition" *Thin Solid Films*, 260, pp. 135-142 (1995).
- Kurosawa et al., "Synthesis and Characterization of Plasma-Polymerized Hexamethyldisiloxane Films," *Thin Solid Films*, 506-507, 176-179 (2006).
- Kwon et al., "Substrate Selectivity of (tBu-Allyl)Co(Co)₃ during Thermal Atomic Layer Deposition of Cobalt," *Chem. Materials*, 24, pp. 1025-1030 (2012).
- Lanford et al., "The Hydrogen Content of Plasmadeposited Silicon Nitride," *J. Appl. Phys.*, 49, 2473 (1978).
- Lee et al., "Characteristics of Low-K SiOC Films Deposited Via Atomic Layer Deposition," *Thin Solid Films* 645, pp. 334-339 (2018).
- Lee et al., Layer Selection by Multi-Level Permutation in 3-D Stacked NAND Flash Memory, *IEEE Electron Device Letters*, vol. 37, No. 7, 866-869 (2016).
- Levy et al., "Reflow Mechanisms of Contact Vias in VLSI Processing" *J. Electrochem. Soc.: Solid-State Science and Technology*, 133, 7, pp. 1417-1424 (1986).
- Li et al., "Metallic Transition-Metal Dichalcogenide Nanocatalysts for Energy Conversion" *Chem.* 4, pp. 1510-1537 (2018).
- Liang et al., "Conversion of Metal Carbides to Carbide Derived Carbon by Reactive Ion Etching in Halogen Gas" *Micro (MEMS) and Nanotechnologies for Space Applications*, Thomas George et al. vol. 6223, 2006 p. 62230J-I to 62230J-11 lines 3-14 in the "Abstract" section and lines 7-9 in the "Introduction" section of p. 1, lines 3-4 in the "Introduction" section and lines 3-4 in the "Experimental Procedure" section of p. 2 (2006).
- Lieberman, et al., "Principles of Plasma Discharges and Materials Processing," Second Edition, 368-381 (2005).
- Lim et al., "Low-Temperature Growth of SiO₂ Films by Plasma-Enhanced Atomic Layer Deposition," *ETRI Journal*, 27 (1), 118-121 (2005).
- Lim et al., "Synthesis and Characterization of Volatile, Thermally Stable, Reactive Transition Metal Amidinates," *Inorg. Chem.*, 42, pp. 7951-7958 (2003).
- Liu et al., "Research, Design, and Experiment of End Effector for Wafer Transfer Robot," *Industrial Robot: An International Journal*, 79-91 (2012).
- Liu et al., "Van der Waals metal-semiconductor junction: Weak Fermi level pinning enables effective tuning of Schottky barrier" *Sci. Adv.* 2: e1600069, 7 pages. (2016).
- Londergan et al., "Engineered Low Resistivity Titanium-Tantalum Nitride Films by Atomic Layer Deposition," *Mat. Res. Soc. Symp. Proc.*, vol. 714E, pp. L5.3.1-L5.3.6 (2001).
- Longrie et al., "Plasma-Enhanced ALD of Platinum with O₂, N₂ and NH₃ Plasmas", *ECS Journal of Solid State Science and Technology*, vol. 1, pp. Q123-Q129 (2012).
- Mackenzie et al., "Stress Control of Si-Based PEVCD Dielectrics," *Proc. Symp. Silicon Nitride and Silicon Dioxide Thin Insulating Films & Other Emerging Dielectrics VIII*, 148-159 (2005).
- Mackus et al., "Optical Emission Spectroscopy as a Tool for Studying Optimizing and Monitoring Plasma-Assisted Atomic Layer Deposition Processes," *Journal of Vacuum Science and Technology*, 77-87 (2010).
- Maeng et al. Electrical properties of atomic layer disposition HfO₂ and HfO_xN_y on Si substrates with various crystal orientations, *Journal of the Electrochemical Society*, 2008-04, p. H267-H271, vol. 155, No. 4, Department of Materials Science and Engineering, Pohang University of Science and Technology, Pohang, Korea (2008).
- Maeno, "Gecko Tape Using Carbon Nanotubes," *Nitto Denko Gihou*, 47, 48-51 (2009).
- Makela et al., "Thermal Atomic Layer Deposition of Continuous and Highly Conducting Gold Thin Films," *Chem. Materials*, 29, pp. 6130-6136 (2017).
- Marsik et al., "Effect of Ultraviolet Curing Wavelength on Low-k Dielectric Material Properties and Plasma Damage Resistance," *Sciencedirect.com*, 519, 11, 3619-3626 (2011).
- Mason et al., "Hydrolysis of Tri-tert-butylaluminum: The First Structural Characterization of Alkylaluminumoxanes [(R₂Al)₂O]_n and (RAIO)_n," *J. American Chemical Society*, vol. 115, No. 12, pp. 4971-4984 (1993).
- Massachusetts Institute of Technology Lincoln Laboratory, "Solid State Research," *Quarterly Technical Report* (1995).
- Mattinen et al., "Crystalline tungsten sulfide thin films by atomic layer deposition and mild annealing" *J. Vac. Sci. Tech.* 37, 020921, 35 pages. (2019).
- Maydannik et al., "Spatial atomic layer deposition: Performance of low temperature H₂O and O₃oxidant chemistry for flexible electronics encapsulation", *Journal of Vacuum Science and Technology: Part A AVS/ AIP*, vol. 33 (1901).
- Meng et al., "Atomic Layer of Deposition of Silicon Nitride Thin Films: A Review of Recent Progress, Challenges, and Outlooks," *Materials*, 9, 1007 (2016).
- Miller et al., "Carbon nitrides: synthesis and characterization of a new class of functional materials," *Phys.Chem.Chem.Phys.*, 19, pp. 15613-15638 (2017).
- Mix et al., "Characterization of plasma-polymerized allyl alcohol polymers and copolymers with styrene," *Adhes. Sci. Technol.*, 21 (2007), S. 487-507.
- Moeen, "Design, Modelling and Characterization of Si/SiGe Structures for IR Bolometer Applications," *KTH Royal Institute of Technology. Information and Communication Technology, Department of Integrated Devices and Circuits, Stockholm Sweden* (2015).
- Morishige et al., "Thermal Desorption and Infrared Studies of Ammonia Amines and Pyridines Chemisorbed on Chromic Oxide," *J. Chem. Soc., Faraday Trans. 1*, 78, 2947-2957 (1982).
- Mosleh et al., "Enhancement of Material Quality of (Si)GeSn Films Grown by SnCl₄ Precursor," *ECS Transactions*, 69 (5), 279-285 (2015).
- Mukai et al., "A Study of CD Budget in Spacer Patterning Technology," *Proc. Of SPIE*, 6924, 1-8 (2008).
- Naito et al., "Electrical Transport Properties in 2H-NbS₂, -NbSe₂, -TaS₂ and -TaSe₂," *J. Of Physical Society of Japan*, vol. 51, No. 1, 219-227 (1982).
- Nakano et al., "Layer-by-Layer Epitaxial Growth of Scalable WSe₂ on Sapphire by Molecular Beam Epitaxy" *Nano. Lett.* 17, pp. 5595-5599 (2017).
- Ngo et al., "Atomic layer deposition of photoactive CoO/SrTiO₃ and CoO/TiO₂ on Si(001) for visible light driven photoelectrochemical water oxidation," *J. Applied Physics*, 114, 9 pages. (2013).
- Nogueira et al., "Production of Highly Hydrophobic Films Using Low Frequency and High Density Plasma," *Revista Brasileira de Aplicacoes de Vacuo*, 25(1), 45-53 (2006).
- Novaro et al. Theoretical Study on a Reaction Pathway of Ziegler-Natta-Type Catalysis, *J. Chem. Phys.* 68(5), Mar. 1, 1978 p. 2337-2351.

(56)

References Cited

OTHER PUBLICATIONS

- Ohchi et al. "Reducing damage to Si substrates during gate etching processes." *Japanese Journal of Applied Physics* 47.7R 5324 (2008).
- Ohtsu et al. "Influences of Gap Distance on Plasma Characteristics in Narrow Gap Capacitively Coupled Radio-Frequency Discharge," vol. 43, No. 2, pp. 795-799 (2004).
- Okamoto et al., "Luminescent Properties of Pr³⁺-sensitized LaPO₄:Gd³⁺ Ultraviolet-B Phosphor Under Vacuum-Ultraviolet Light Excitation," *J. App. Phys.* 106, 013522 (2009).
- Park, "Substituted Aluminum Metal Gate on High-K Dielectric for Low Work-Function and Fermi-Level Pinning Free," 4 pages, *IEEE* 0-7803-8684-1/04 (2004).
- Pichler. "Intrinsic Point Defects, Impurities and Their Diffusion in Silicon," Springer-Verlag Wien, p. 367 (2004).
- Portet et al., "Impact of Synthesis Conditions on Surface Chemistry and Structure of Carbide-Derived Carbons," *Thermochimica Acta*, 497, 137-142 (2010).
- Potts et al., "Low Temperature Plasma-Enhanced Atomic Layer Deposition of metal Oxide Thin Films," *Journal of the Electrochemical Society*, 157, 66-74 (2010).
- Potts et al., "Room-Temperature ALD of Metal Oxide Thin Films by Energy-Enhanced ALD", *Chemical Vapor Deposition*, vol. 19, pp. 125-133 (2013).
- Presser, et al., "Effect of Pore Size on Carbon Dioxide Sorption by Carbide Derived Carbon," *Energy & Environmental Science* 4.8, 3059-3066 (2011).
- Provine et al., "Correlation of Film Density and Wet Etch Rate in Hydrofluoric Acid of Plasma Enhanced Atomic Layer Deposited Silicon Nitride," *AIP Advances*, 6 (2016).
- Qin et al., "Chemical Vapor Deposition Growth of Degenerate p-Type Mo-Doped ReS₂ Films and Their Homojunction," *ACS Appl. Mater. Interfaces*, 9(18), pp. 15583-15591 (2007).
- Radamson et al. "Growth of Sn-alloyed Group IV Materials for Photonic and Electronic Applications" Chapter 5 pp. 129-144, *Manufacturing Nano Structures* (2014).
- Rossing et al. "Acoustics of Eastern and Western bells, Old and New" *J of Acoustical Society of Japan*; 10(5); pp. 241-252 (1989).
- Ryu et al., "Persistent Charge-Density-Wave Order in Single-Layer TaSe₂" *Nano. Lett.* 18, pp. 689-694 (2018).
- Saeki et al. "Reaction Process of Vanadium Tetrachloride with Ammonia in the Vapor Phase and Properties of the Vanadium Nitride Formed" *Bull. Chem. Soc. Jpn.*, 55, pp. 3446-3449 (1982).
- Sakuma et al., "Highly Scalable Horizontal Channel 3-D NAND Memory Excellent in Compatibility with Conventional Fabrication Technology," *IEEE Electron Device Letters*, vol. 34, No. 9, 1142-1144 (2013).
- Salim, "In-situ Fourier Transform Infrared Spectroscopy of Chemistry and Growth in Chemical Vapor Deposition," *Massachusetts Institute of Technology*, 187 pages (1995).
- Salim et al., "In Situ Concentration Monitoring in a Vertical OMVPE Reactor by Fiber-Optics-Based Fourier Transform Infrared Spectroscopy," *Journal of Crystal Growth* 169, pp. 443-449, Elsevier Science B.V. (1996).
- Samal et al., "Low-Temperature (<200° C) Plasma Enhanced Atomic Deposition of Dense Titanium Nitride Thin Films" (2012).
- Sanders et al., "Crystalline and electronic structure of single-layer TaS₂" *Phys. Rev. B.* 94, 081404, 6 pages. (2016).
- Schindler, Dissertation, Next Generation High-k Dielectrics for DRAM Produced by Atomic Layer Deposition Studied by Transmission Electron Microscopy (2015).
- Schmatz et al., "Unusual Isomerization Reactions in 1,3-Diaza-2-Silacyclopentanes," *Organometallics*, 23, 1180-1182 (2004).
- Sellers, Making Your Own Timber Dogs, Paul Sellers blog, Published on Nov. 18, 2014, [online], [site visited Jun. 10, 2017]. Available from Internet, <URL: <https://paulsellers.com/2014/11/making-your-own-timber-dogs/>>.
- Selvaraj et al., "Selective Atomic Layer Deposition of Zirconia on Copper Patterned Silicon Substrates Using Ethanol as Oxygen Source as Well as Copper Reductant," *J. Vac. Sci. Technol.* A32(1), (2014).
- Selvaraj et al., "Surface Selective Atomic Layer Deposition of Hafnium Oxide for Copper Diffusion Barrier Application Using Tetrakis (diethylamino) Hafnium and Ethanol," 225th ECS Meeting, Meeting Abstract, (May 12, 2014).
- Seshadri et al., "Ultrathin Extreme Ultraviolet Patterning Stack Using Polymer Brush As an Adhesion Promotion Layer," *Journal of Micro/Nanolithography, MEMS, and MOEMS* 16(3) (2017).
- Shamma et al., "PDL Oxide Enabled Doubling," *Proc. Of SPIE*, 6924, 69240D, 1-10 (2008).
- Simchi et al., "Sulfidation of 2D transition metals (Mo, W, Re, Nb, Ta): thermodynamics, processing, and characterization" *J. Materials Science* 52: 17, 9 pages (2017).
- Stanley et al. "Feedgas for Modern High-Performance Ozone Generators" *Ozonia Ltd., Duebendorf, Switzerland.* 7 pages. Available Jul. 14, 2017 online at: http://www.degremont-technologies.com/cms_medias/pdf/tech_ozonia_feedgas.pdf (1999).
- Svetin et al., "Three-dimensional resistivity and switching between correlated electronic states in 1T-TaS₂" *Nature, Scientific Reports* Apr. 12, 2017, 7:46048, 10 pages (2017).
- Tatehaha et al., "Adhesion Energy of Polystyrene and Substrate in Function Water," 5th International Symposium of Cleaning Technology in Semiconductor Device Manufacturing, pp. 560-565 (1998).
- Tidman et al. "Resistivity of thin TaS₂ crystals," *Can. J. Phys.*, vol. 54, 2306-2309 (1976).
- Todi et al., "Characterization of Pt-Ru Binary Alloy Thin Films for Work Function Tuning," *IEEE Electron Device Letters*, vol. 27, No. 7, pp. 542-545 (2006).
- Trumbore et al. "Solid solubilities of aluminum and gallium in germanium," *J. of Physics and Chemistry of Solids*, vol. 11, Issues 3-4, 239-240 (1959).
- Tseng et al., "Etch Properties of Resists Modified by Sequential Infiltration Synthesis," *American Vacuum Society* (2011).
- Tseng et al., "Enhanced Block Copolymer Lithography Using Sequential Infiltration Synthesis," *Journal of Physical Chemistry*, vol. 5, 17725-17729 (2011).
- Ueda et al. "Enhanced Sidewall Grown (ESG) process: towards PEALD with conformality above 100%," *Extended Abstracts of the 2011 International Conference on Solid State Devices and Materials*, Nagoya, pp. 34-35 (2011).
- Varma, et al., "Effect of Metal Halides on Thermal, Mechanical, and Electrical Properties of Polypyromellitimide Films," *Journal of Applied Polymer Science*, vol. 32, pp. 3987-4000, (1986).
- Vasilev, "Borophosphosilicate Glass Films in Silicon Microelectronics, Part 1: Chemical Vapor Deposition, Composition, and Properties" *Russian Microelectronics*, vol. 33, No. 5, pp. 271-284 (2004).
- Voltaix, "Material Safety Data Sheet for: Trisilylamine", pp. 1-8, (2014).
- Wang et al., "Tertiarybutylaluminum as an Organometallic Source for Epitaxial Growth of AlGaSb," *Appl. Phys. Lett.* 67 (10), Sep. 4, pp. 1384-1386, *American Institute of Physics* (1995).
- Wirths, et al, "SiGeSn Growth studies Using Reduced Pressure Chemical Vapor Deposition Towards Optoelectronic Applications," *This Soid Films*, 557, 183-187 (2014).
- Xing et al., "Ising Superconductivity and Quantum Phase Transition in Macro-Size Monolayer NbSe₂" *Nano. Lett.* 17, pp. 6802-6807 (2017).
- Xu et al., "14NM Metal Gate Film Stack Development and Challenges," *SMIC et al.* (2016).
- Xu et al., "Contacts between Two- and Three-Dimensional Materials: Ohmic, Schottky, and p-n Heterojunctions" *ACS Nano* 10, pp. 4895-4919 (2016).
- Yoshida, et al., Threshold Voltage Tuning for 10NM and Beyond CMOS Integration, *Solid State Technology*, 57(7): 23-25 (2014).
- Yu et al., "Modulation of the Ni FUSI Workfunction by Yb Doping: from Midgap to N-Type Band-Edge," 4 pages, *IEEE* 0-7803-9269-8/05 (2005).
- Yuan et al., "Facile Synthesis of Single Crystal Vanadium Disulfide Nanosheets by Chemical Vapor Deposition for Efficient Hydrogen Evolution Reaction" *Adv. Mater.* 27, pp. 5605-5609 (2015).
- Yun et al., "Behavior of Various Organosilicon Molecules in PECVD Processes for Hydrocarbon-Doped Silicon Oxide Films," *Solid State Phenomena*, vol. 124-126, 347-350 (2007).

(56)

References Cited

OTHER PUBLICATIONS

Yun et al., "Comparison of Atomic Scale Etching of Poly-Si in Inductively Coupled Ar and He Plasmas", Korean Journal of Chemical Engineering, vol. 24, 670-673 (2007).

Yun et al., "Single-Crystalline Si Stacked Array (STAR) NAND Flash Memory," IEEE Transactions on Electron Devices, vol. 58, No. 4, 1006-1014 (2011).

Yun et al., "Effect of Plasma on Characteristics of Zirconium Oxide Films Deposited by Plasma-Enhanced Atomic Layer Deposition," Electrochemical and Solid State Letters, 8(11) F47-F50 (2005).

Yushin et al., "Carbon-Derived Carbon," Department of Materials Science and Engineering, Taylor & Francis Group, LLC (2006).

Zhou et al., "A library of atomically thin metal chalcogenides" Nature 556, pp. 355-361 (2018).

Chemistry Stack Exchange, "Why is CF4 Non-Polar and CHF3 Polar," <https://chemistry.stackexchange.com/questions/31604/why-is-cf4-non-polar-and-chf3-polar>, (2015).

Crystal IS "Application Note: Using UV Reflective Materials to Maximize Disinfection"; AN011; Jun. 16, 2016.

IPS Water Heater Pan Adapter Kit, Nov. 1, 2015, [online], [site visited Dec. 4, 2019]; URL: <http://es.ipscorp.com/watertite/protectivesystem/whpanadapter> (2015).

"Polyurethane_HF"; webpage; no date. Cited in Notice of References dated May 18, 2017 in U.S. Appl. No. 14/884,695.

Rhenium trioxide; https://en.wikipedia.org/wiki/Rhenium_trioxide [online]; last edited on Feb. 18, 2017.

Scientific and Technical Information Center EIC 2800 Search Report dated Feb. 16, 2012.

CNIPA; Notice of Allowance dated May 22, 2020 in Application No. 201610028064.1.

CNIPA; Office Action dated Mar. 26, 2020 in Application No. 201610131743.1.

CNIPA; Office Action dated May 18, 2020 in Application No. 201610982040.X.

CNIPA; Office Action dated May 29, 2020 in Application No. 201710131319.1.

CNIPA; Office Action dated Jun. 1, 2020 in Application No. 201710173292.2.

CNIPA; Notice of Allowance dated May 14, 2020 in Application No. 201930615780.4.

CNIPA; Notice of Allowance dated Apr. 27, 2020 in Application No. 201930660355.7.

CNIPA; Notice of Allowance dated Jun. 2, 2020 in Application No. 202030048819.1.

CNIPA; Notice of Allowance dated May 15, 2020 in Application No. 202030048854.3.

CNIPA; Notice of Allowance dated May 15, 2020 in Application No. 202030053560.X.

CNIPA; Notice of Allowance dated May 20, 2020 in Application No. 202030053634.X.

KIPO; Notice of Allowance dated Apr. 23, 2020 in Application No. 10-2013-0050740.

KIPO; Office Action dated Jun. 19, 2020 in Application No. 10-2013-0098575.

KIPO; Notice of Allowance dated May 14, 2020 in Application No. 10-2013-0102026.

KIPO; Office Action dated May 21, 2020 in Application No. 10-2014-0086902.

KIPO; Office Action dated May 21, 2020 in Application No. 10-2014-0091092.

KIPO; Office Action dated Apr. 22, 2020 in Application No. 10-2020-0009462.

TIPO; Notice of Allowance dated May 4, 2020 in Application No. 105101536.

TIPO; Office Action dated Apr. 14, 2020 in Application No. 105129977.

TIPO; Office Action dated Mar. 17, 2020 in Application No. 105130130.

TIPO; Office Action dated Feb. 21, 2020 in Application No. 108120947.

USPTO; Advisory Action dated Apr. 24, 2020 in U.S. Appl. No. 14/219,839.

USPTO; Advisory Action dated Apr. 24, 2020 in U.S. Appl. No. 14/219,879.

USPTO; Non-Final Office Action dated Apr. 28, 2020 in U.S. Appl. No. 14/444,744.

USPTO; Final Office Action dated May 15, 2020 in U.S. Appl. No. 14/457,058.

USPTO; Advisory Action dated Jun. 22, 2020 in U.S. Appl. No. 14/829,565.

USPTO; Final Office Action dated Jun. 1, 2020 in U.S. Appl. No. 15/135,258.

USPTO; Non-Final Office Action dated Apr. 16, 2020 in U.S. Appl. No. 15/286,503.

USPTO; Final Office Action dated May 13, 2020 in U.S. Appl. No. 15/377,439.

USPTO; Non-Final Office Action dated May 27, 2020 in U.S. Appl. No. 15/402,993.

USPTO; Final Office Action dated Apr. 17, 2020 in U.S. Appl. No. 15/491,726.

USPTO; Final Office Action dated Jun. 16, 2020 in U.S. Appl. No. 15/636,307.

USPTO; Notice of Allowance dated May 20, 2020 in U.S. Appl. No. 15/672,096.

USPTO; Final Office Action dated May 27, 2020 in U.S. Appl. No. 15/690,017.

USPTO; Advisory Action dated Jun. 19, 2020 in U.S. Appl. No. 15/691,241.

USPTO; Advisory Action dated May 26, 2020 in U.S. Appl. No. 15/798,201.

USPTO; Advisory Action dated May 19, 2020 in U.S. Appl. No. 15/802,154.

USPTO; Non-Final Office Action dated Apr. 24, 2020 in U.S. Appl. No. 15/815,483.

USPTO; Final Office Action dated Jun. 11, 2020 in U.S. Appl. No. 15/861,418.

USPTO; Advisory Action dated Jun. 5, 2020 in U.S. Appl. No. 15/890,037.

USPTO; Final Office Action dated Jun. 15, 2020 in U.S. Appl. No. 15/896,986.

USPTO; Non-Final Office Action dated May 1, 2020 in U.S. Appl. No. 15/917,224.

USPTO; Advisory Action dated May 15, 2020 in U.S. Appl. No. 15/923,834.

USPTO; Non-Final Office Action dated May 1, 2020 U.S. Appl. No. 15/925,532.

USPTO; Advisory Action dated Apr. 23, 2020 in U.S. Appl. No. 15/940,759.

USPTO; Final Office Action dated Apr. 30, 2020 in U.S. Appl. No. 15/962,980.

USPTO; Non-Final Office Action dated May 15, 2020 in U.S. Appl. No. 15/974,988.

USPTO; Non-Final Office Action dated Jun. 12, 2020 in U.S. Appl. No. 15/985,539.

USPTO; Non-Final Office Action dated Feb. 20, 2020 in U.S. Appl. No. 15/996,286.

USPTO; Non-Final Office Action dated Jun. 5, 2020 in U.S. Appl. No. 16/000,125.

USPTO; Non-Final Office Action dated Apr. 22, 2020 in U.S. Appl. No. 16/000,156.

USPTO; Non-Final Office Action dated May 7, 2020 in U.S. Appl. No. 16/004,041.

USPTO; Notice of Allowance dated Jun. 24, 2020 in U.S. Appl. No. 16/014,981.

USPTO; Notice of Allowance dated May 26, 2020 in U.S. Appl. No. 16/036,692.

USPTO; Non-Final Office Action dated Apr. 30, 2020 in U.S. Appl. No. 16/055,532.

USPTO; Non-Final Office Action dated May 27, 2020 in U.S. Appl. No. 16/100,012.

USPTO; Final Office Action dated Jun. 23, 2020 in U.S. Appl. No. 16/105,745.

(56)

References Cited

OTHER PUBLICATIONS

USPTO; Final Office Action dated Apr. 21, 2020 in U.S. Appl. No. 16/105,761.
USPTO; Final Office Action dated Jun. 26, 2020 in U.S. Appl. No. 16/105,802.
USPTO; Non-Final Office Action dated Jun. 22, 2020 in U.S. Appl. No. 16/128,282.
USPTO; Non-Final Office Action dated Apr. 21, 2020 in U.S. Appl. No. 16/130,798.
USPTO; Final Office Action dated Jun. 5, 2020 in U.S. Appl. No. 16/132,142.
USPTO; Advisory Action dated Jun. 9, 2020 in U.S. Appl. No. 16/158,077.
USPTO; Notice of Allowance dated Jun. 19, 2020 in U.S. Appl. No. 16/161,744.
USPTO; Non-Final Office Action dated May 29, 2020 in U.S. Appl. No. 16/205,899.
USPTO; Final Office Action dated Jun. 19, 2020 in U.S. Appl. No. 16/219,555.
USPTO; Final Office Action dated Jun. 15, 2020 in U.S. Appl. No. 16/242,829.
USPTO; Notice of Allowance dated May 29, 2020 in U.S. Appl. No. 16/245,006.
USPTO; Non-Final Office Action dated Apr. 24, 2020 in U.S. Appl. No. 16/251,534.
USPTO; Non-Final Office Action dated May 27, 2020 in U.S. Appl. No. 16/252,567.
USPTO; Non-Final Office Action dated Apr. 16, 2020 in U.S. Appl. No. 16/255,639.
USPTO; Non-Final Office Action dated Jun. 30, 2020 in U.S. Appl. No. 16/258,187.
USPTO; Notice of Allowance dated May 21, 2020 in U.S. Appl. No. 16/280,964.
USPTO; Notice of Allowance dated Apr. 16, 2020 in U.S. Appl. No. 16/427,288.
USPTO; Non-Final Office Action dated May 12, 2020 in U.S. Appl. No. 16/454,063.
USPTO; Notice of Allowance dated Apr. 17, 2020 in U.S. Appl. No. 16/455,406.

USPTO; Non-Final Office Action dated Jun. 11, 2020 in U.S. Appl. No. 16/598,768.
USPTO; Notice of Allowance dated Apr. 21, 2020 in U.S. Appl. No. 16/674,894.
USPTO; Non-Final Office Action dated Apr. 13, 2020 in U.S. Appl. No. 16/833,279.
USPTO; Notice of Allowance dated Jun. 10, 2020 in U.S. Appl. No. 29/615,000.
USPTO; Non-Final Office Action dated Apr. 24, 2020 in U.S. Appl. No. 29/726,623.
WIPO; International Search Report and Written Opinion dated Apr. 29, 2019 in U.S. Appl. No. PCT/NL2018/050791.
Chatterjee et al. "Chemical Vapor Deposition of Boron Nitride Nanosheets on Metallic Substrates via Decaborane/Ammonia Reactions", *Chem. Mater.* 23, pp. 4414-4416 (2011).
Fallica et al., "Dynamic Absorption Coefficients Of Chemically Amplified Resists And Nonchemically Amplified Resists At Extreme Ultraviolet", *J. Micro/Nanolith. MEMS MOEMS* 15(3), pp. 033506-1-033506-7 (2016).
Glass et al. "The Chemical Vapor Deposition of Metal Boride Thin Films from Polyhedral Cluster Species", Winter and Hoffman, *Inorganic Materials Synthesis. ACS Symposium Series; American Chemical Society: Washington DC, Chapter 10*, pp. 130-143 (1999).
Jensen et al. "Titanium, Zirconium, and Hafnium Tetrahydroborates as "Tailored" CVD Precursors for Metal Diboride Thin Films", *J. Am. Chem. Soc.* 110, pp. 1643-1644 (1988).
Kliem et al. "Silyl Group Migrations Between Oxygen and Nitrogen in Aminosiloxanes"; *Organosilicon Chemistry VI: from Molecules to Materials*; pp. 216-221 (2005).
Lewis et al. "Hawley's Condensed Chemical Dictionary" 12th Edition; excerpt pp. 1027-1038 (2005).
Roddy, "Transport Reactions and Vaporization Studies of Some Vanadium Halides", Iowa State university of Science and Technology dissertation, 207 pages (1962).
Spear et al., "Chemical Transport Reactions in the Vanadium-Silicon-Oxygen System and the Ternary Phase Diagram", *Journal of the Less-Common Metals*, 14, pp. 69-75 (1968).
Su et al. "A Polymer Precursor Route to Metal Borides", *Chem. Mater.*, 5, pp. 1659-1668 (1993).
TIPO; Notice of Allowance dated Jan. 30, 2019 in Application No. 103132230.

* cited by examiner

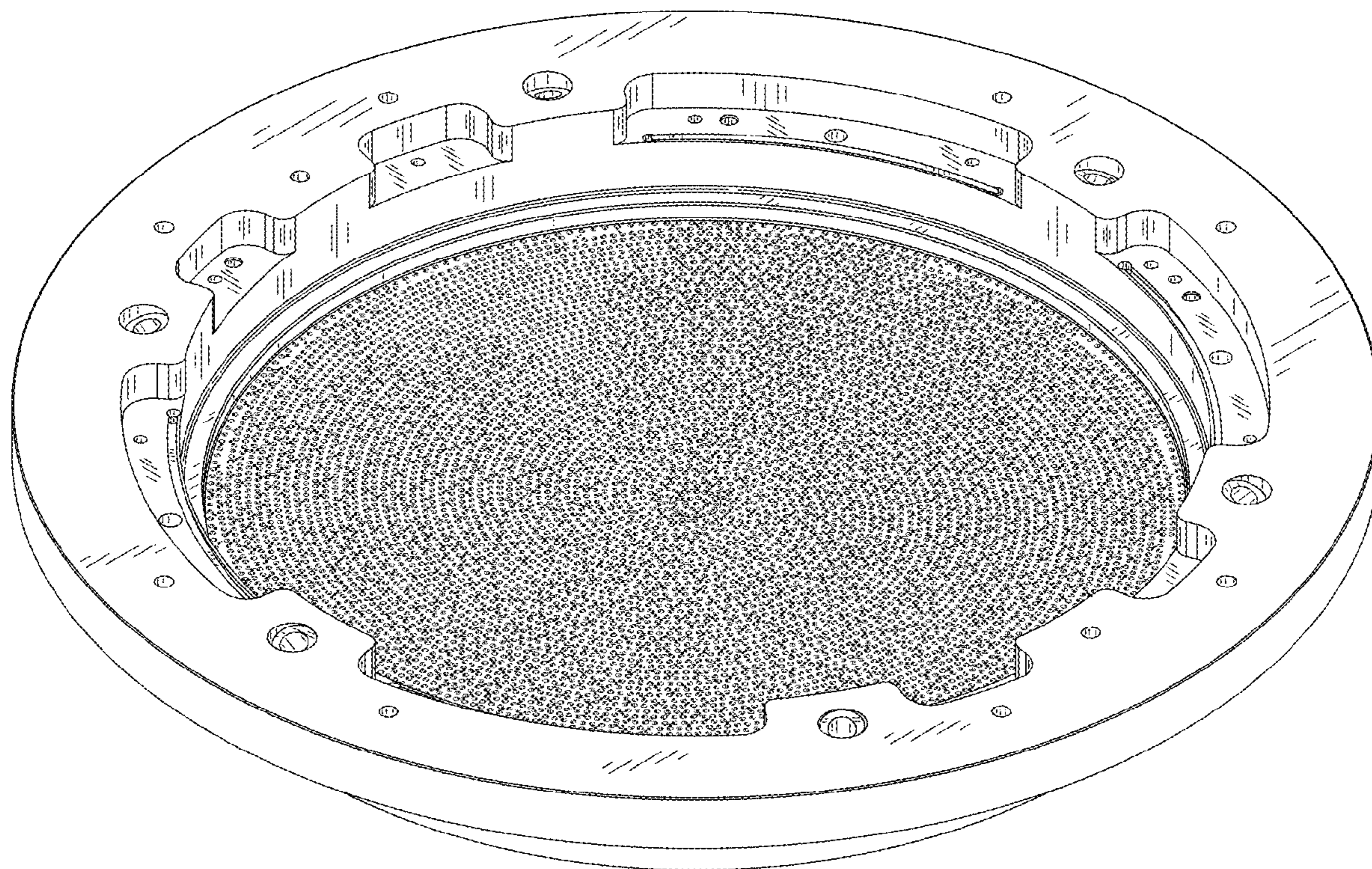

FIG.1

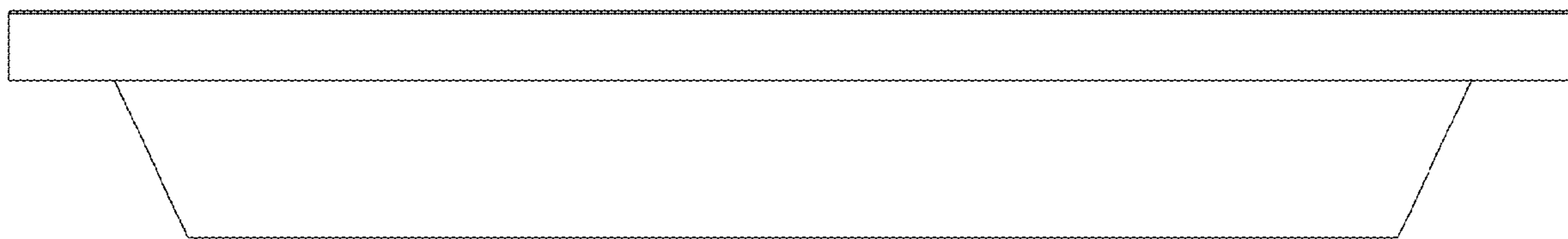

FIG.2

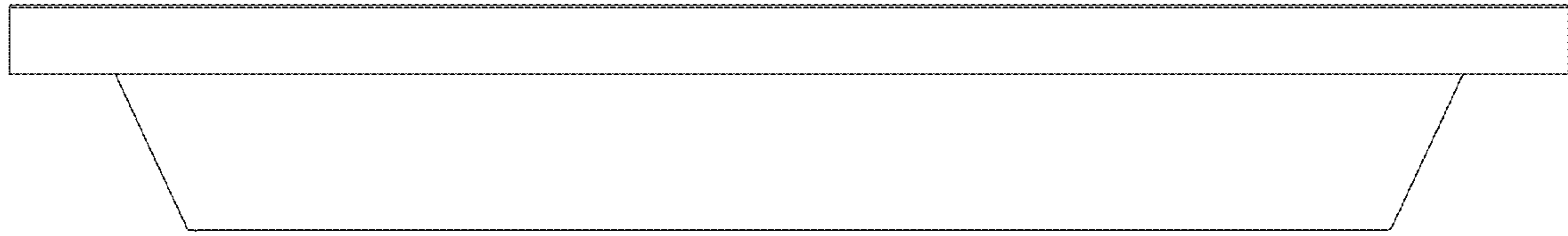

FIG.3

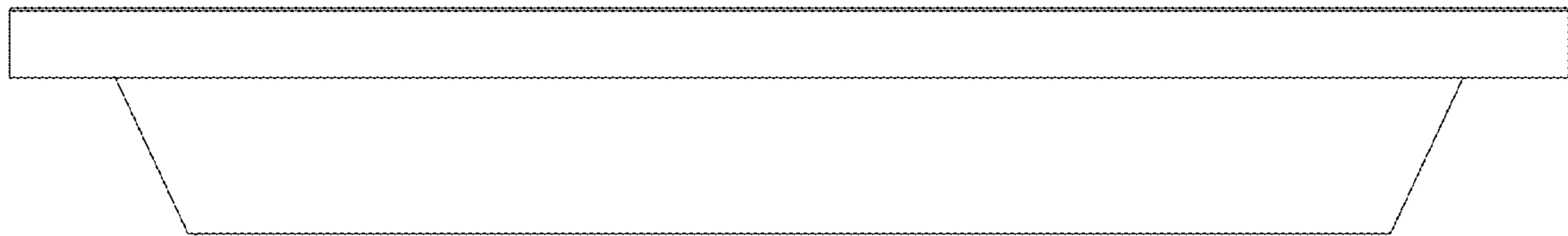

FIG.4

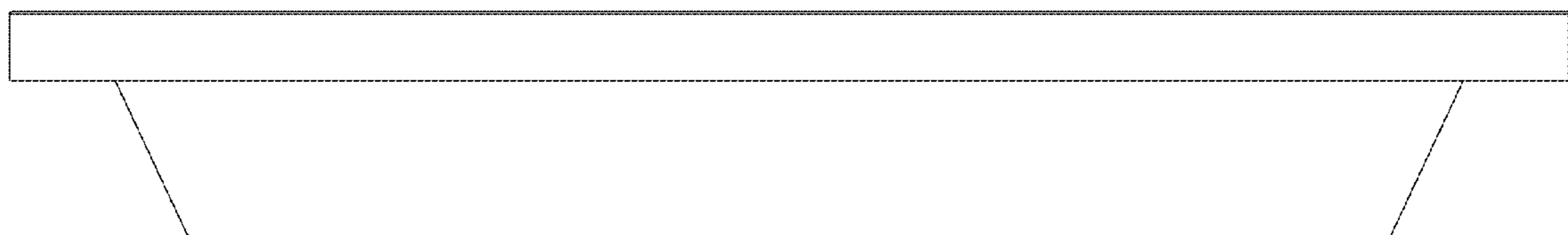

FIG.5

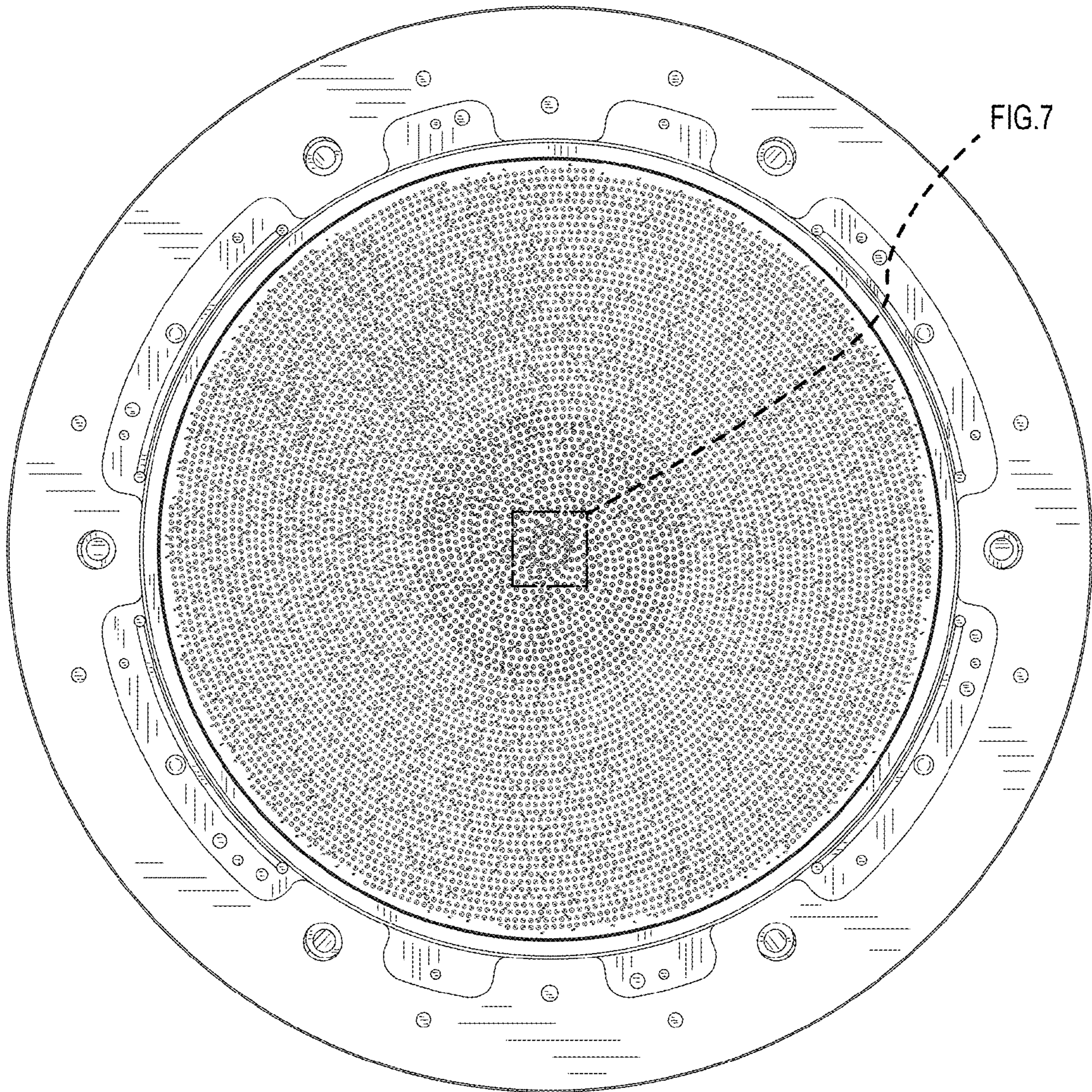

FIG.6

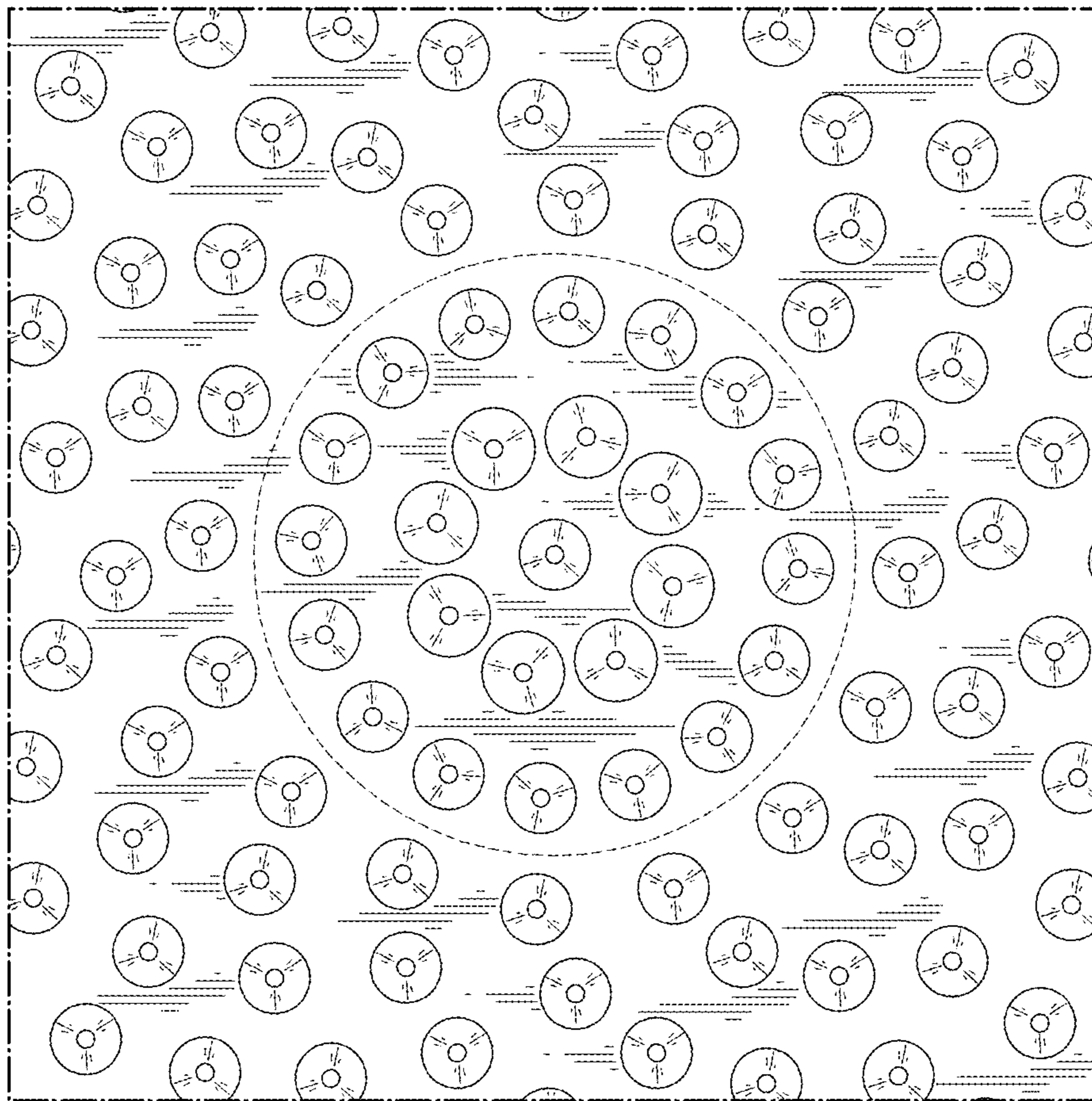

FIG.7

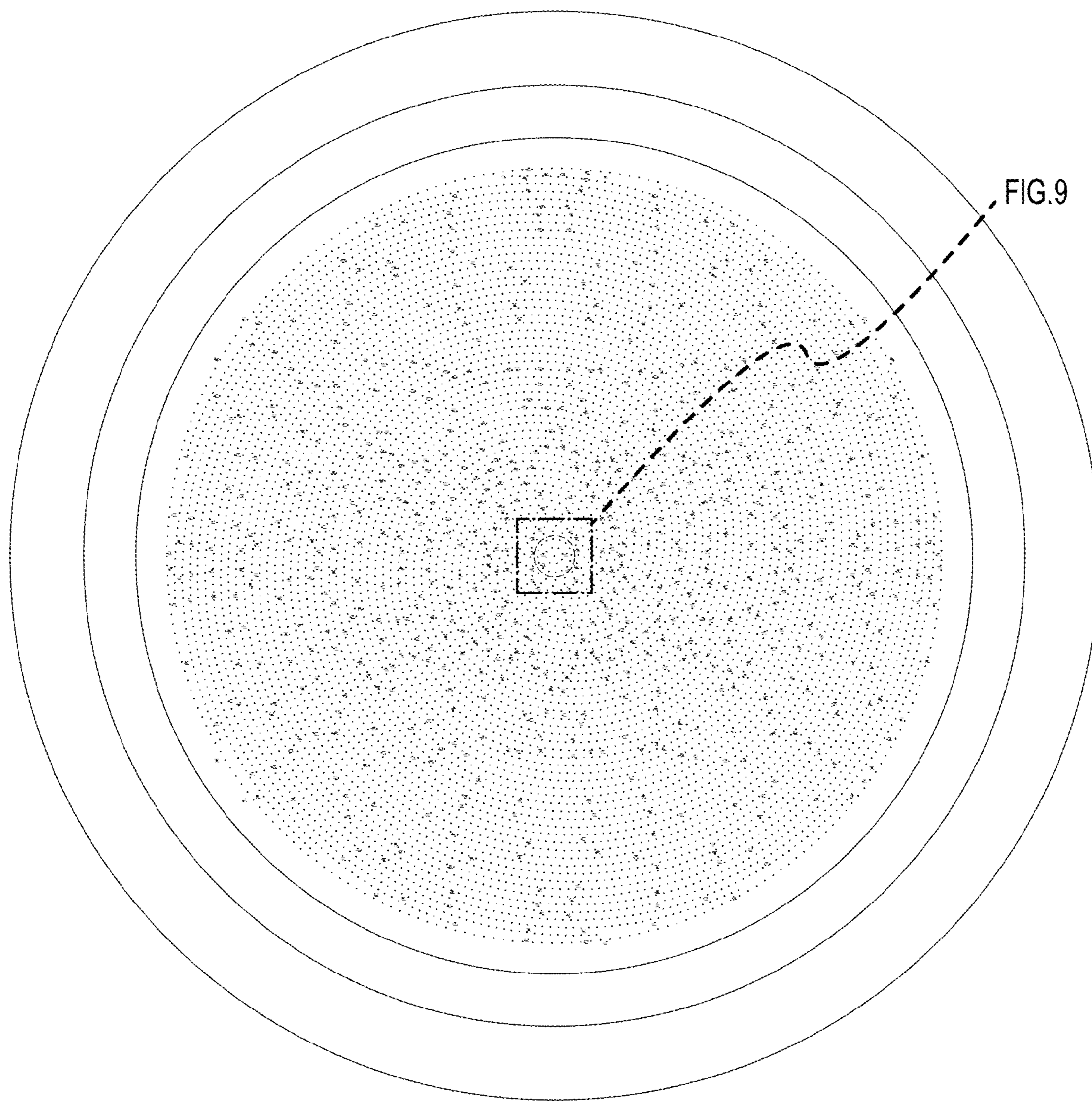

FIG. 8

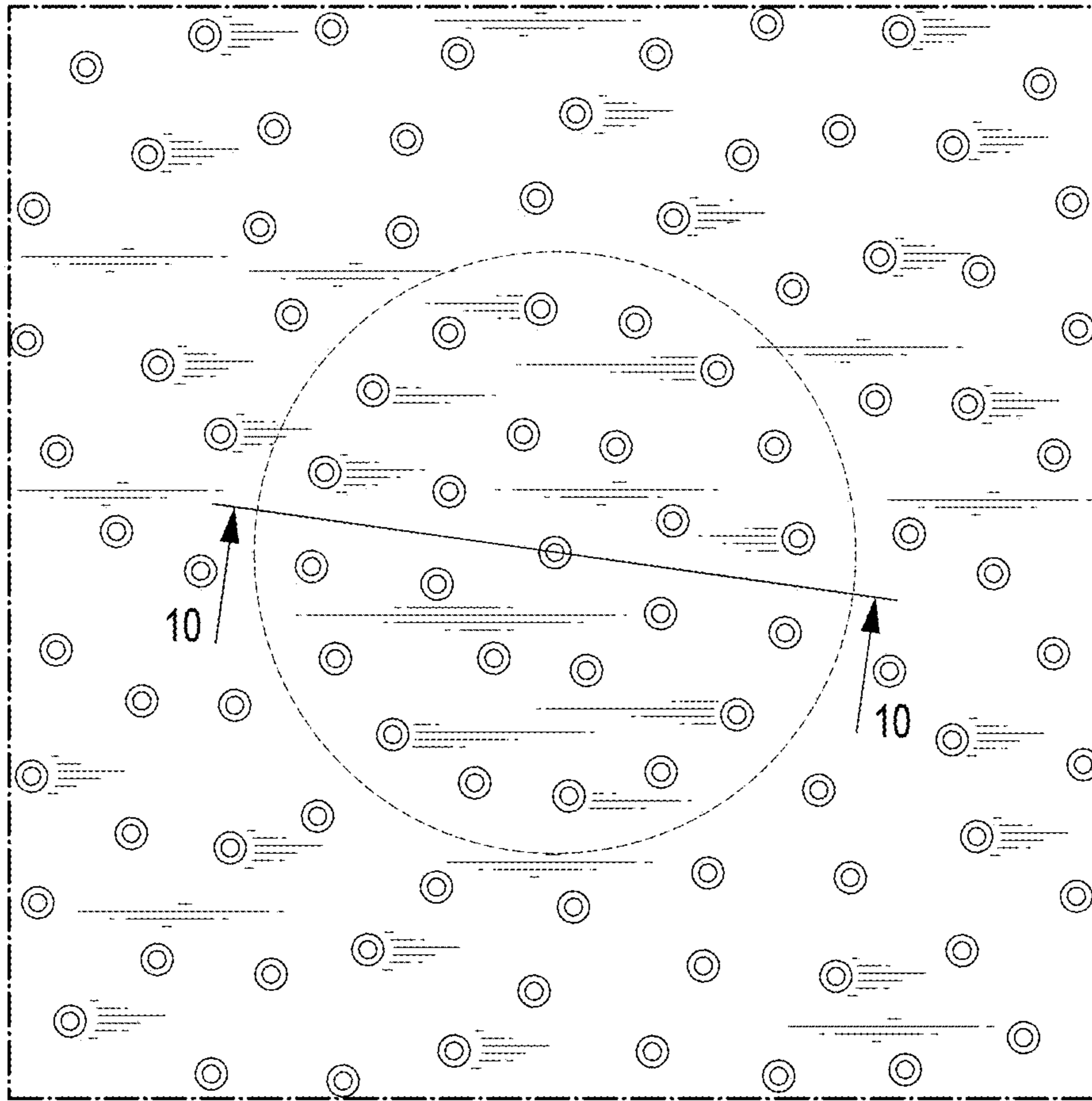

FIG. 9

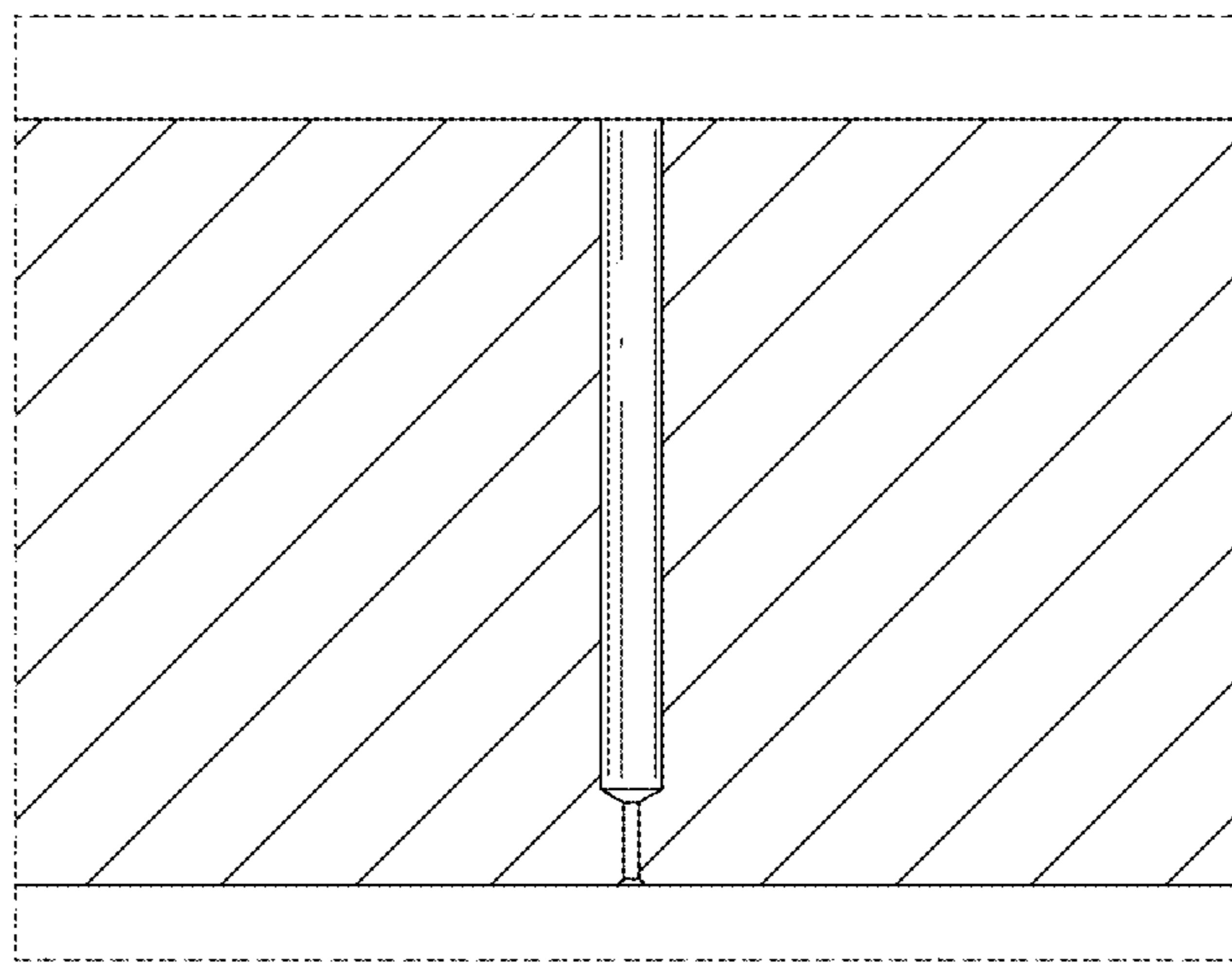

FIG. 10