



US00D913924S

(12) **United States Design Patent**  
**Nanbu et al.**

(10) **Patent No.:** **US D913,924 S**  
(45) **Date of Patent:** **\*\* Mar. 23, 2021**

(54) **MOTOR**

D526,275 S \* 8/2006 Han ..... D13/112  
D551,167 S \* 9/2007 Kubota ..... D13/112  
D709,450 S \* 7/2014 Tanabe ..... D13/112

(71) Applicant: **Panasonic Intellectual Property Management Co., Ltd., Osaka (JP)**

(Continued)

(72) Inventors: **Yasuo Nanbu, Osaka (JP); Takanori Amaya, Osaka (JP)**

**FOREIGN PATENT DOCUMENTS**

CN 304634810 S 5/2018  
JP D1344743 11/2008

(Continued)

(73) Assignee: **Panasonic Intellectual Property Management Co., Ltd., Osaka (JP)**

*Primary Examiner* — Derrick E Holland

(\*\*) Term: **15 Years**

(74) *Attorney, Agent, or Firm* — Panasonic IP Management; Kerry S. Culpepper

(21) Appl. No.: **29/715,398**

(57) **CLAIM**

(22) Filed: **Dec. 2, 2019**

We claim the ornamental design for a motor, as shown and described.

(30) **Foreign Application Priority Data**

**DESCRIPTION**

Jun. 20, 2019 (JP) ..... 2019-013609

FIG. 1 is a front perspective view of a motor of the present invention;

(51) **LOC (13) Cl.** ..... **13-01**

FIG. 2 is a rear perspective view thereof;

(52) **U.S. Cl.**

FIG. 3 is a front view thereof;

USPC ..... **D13/112**

FIG. 4 is a rear view thereof;

(58) **Field of Classification Search**

FIG. 5 is a first side view thereof;

USPC ..... D13/101, 112, 113, 114, 117, 118, 120,  
D13/122, 199; D15/1, 3, 5, 199;  
D23/370, 377

FIG. 6 is a second side view thereof;

CPC . F02B 63/04; H02K 3/24; H02K 3/47; H02K  
1/12; H02K 5/02; H02K 5/04; H02K  
5/08; H02K 5/18; H02K 5/20; H02K  
11/0094; H02K 9/06; H02K 9/14

FIG. 7 is a top view thereof;

See application file for complete search history.

FIG. 8 is a bottom view thereof;

(56) **References Cited**

FIG. 9 is a cross-sectional view taken along the line 9-9 in FIG. 3;

**U.S. PATENT DOCUMENTS**

4,673,837 A \* 6/1987 Gingerich ..... H02K 5/148  
29/597  
5,883,449 A \* 3/1999 Mehta ..... F04D 25/082  
310/417  
D409,564 S \* 5/1999 Koshida ..... D13/112

FIG. 10 is an end view of the sectioned part taken along the line 10-10 in FIG. 6;

FIG. 11 is an enlarged view of the area marked as 11 in FIG. 9; and,

FIG. 12 is an enlarged view of the area marked as 12 in FIG. 10.

The broken lines in the drawings represent portions of the motor that form no part of the claimed design. Additionally, the dash-dot-dashed broken lines in the drawings define the boundaries of the claimed design and form no part thereof.

**1 Claim, 12 Drawing Sheets**

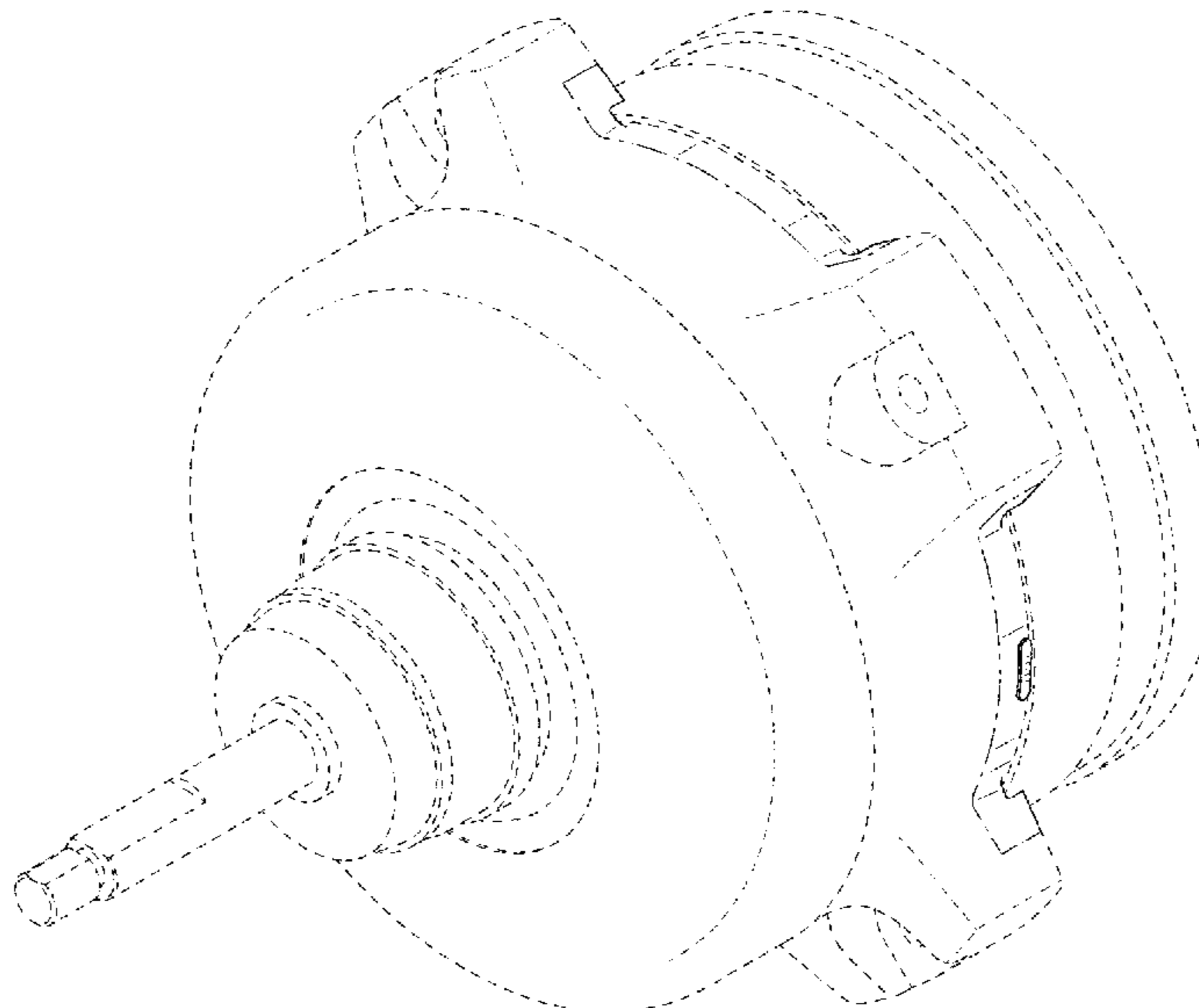

(56)

**References Cited**

U.S. PATENT DOCUMENTS

D710,801 S \* 8/2014 Tanaka ..... D13/112  
D741,260 S \* 10/2015 Yabuuchi ..... D13/112  
9,172,283 B2 \* 10/2015 Li ..... H02K 5/02  
D753,591 S \* 4/2016 Noda ..... D13/112  
D786,794 S \* 5/2017 McCormick ..... D13/112  
D790,467 S \* 6/2017 Marth ..... D13/112  
9,822,642 B2 \* 11/2017 Anderson ..... B64D 27/16  
D806,650 S \* 1/2018 Chang ..... D13/112  
D836,551 S \* 12/2018 Kaneko ..... D13/112  
D842,246 S \* 3/2019 Gan ..... D13/112  
D853,445 S \* 7/2019 Kuratani ..... D15/1  
D860,942 S \* 9/2019 Hilker ..... D13/112  
D886,737 S \* 6/2020 Nanbu ..... D13/112  
2015/0249376 A1 \* 9/2015 Hiwaki ..... H02K 5/08  
310/43

FOREIGN PATENT DOCUMENTS

JP D1372992 11/2009  
JP D1411473 4/2011  
JP D1630777 5/2019

\* cited by examiner

FIG. 1

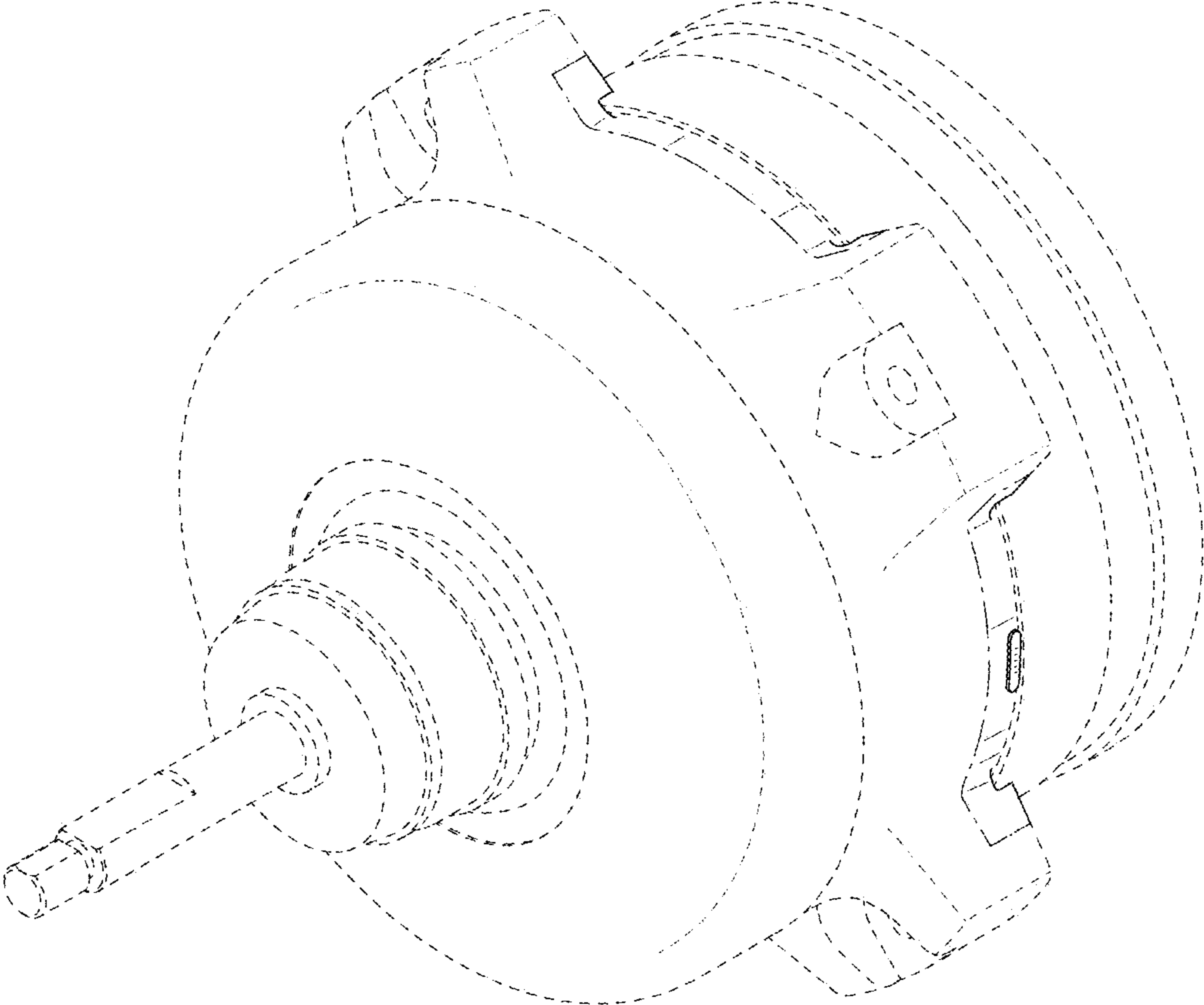

FIG. 2

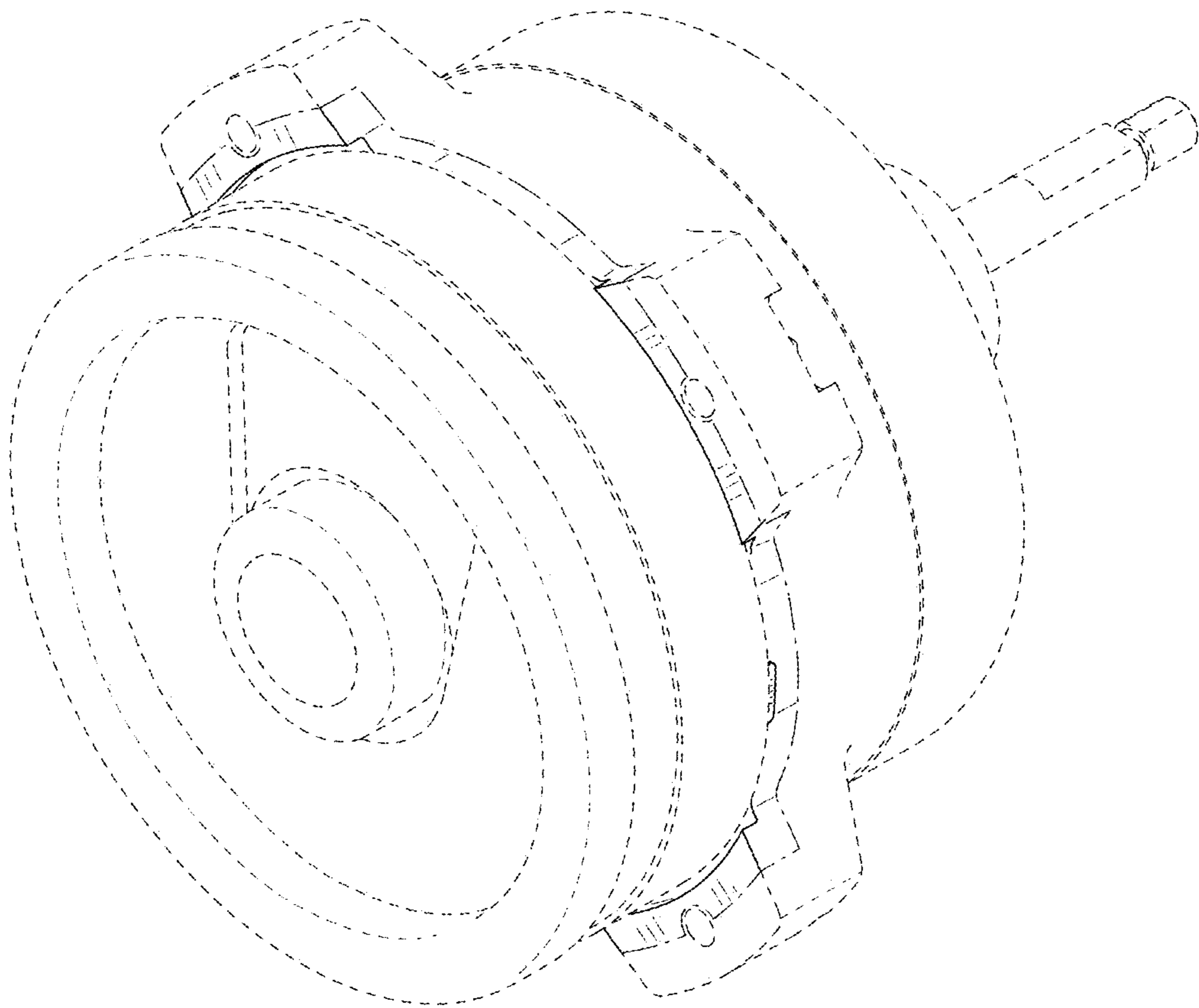

FIG. 3

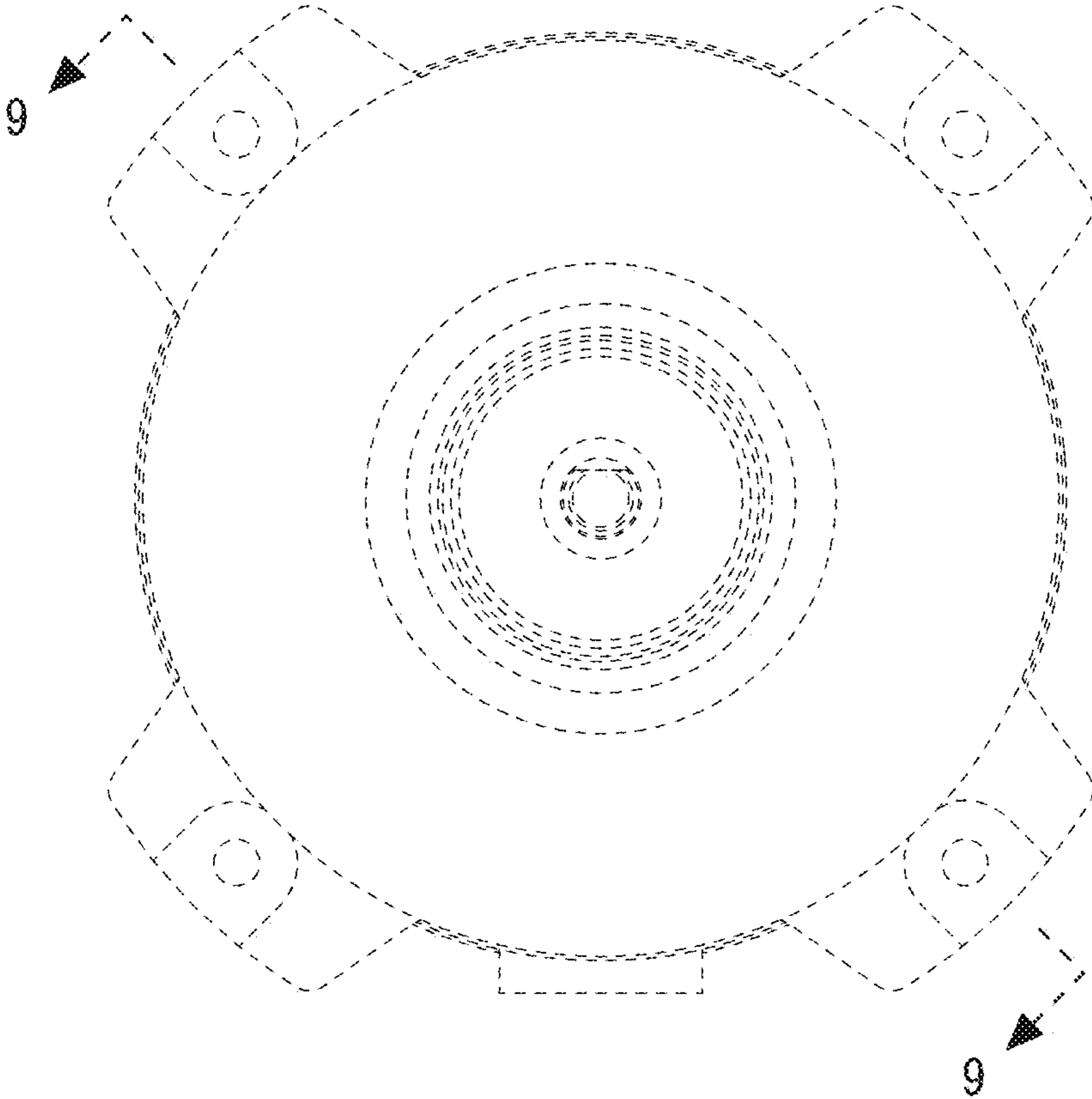

FIG. 4

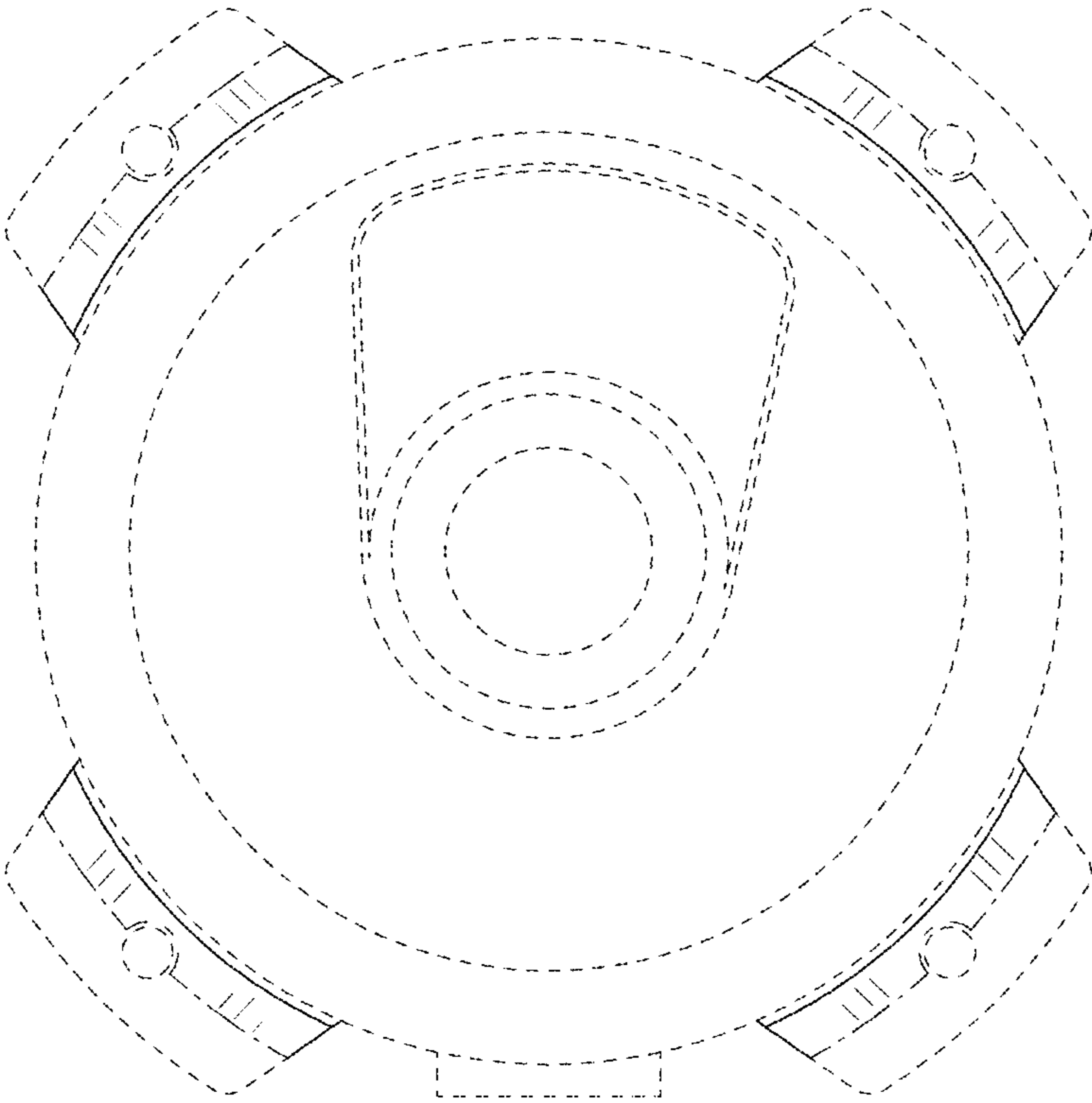

FIG. 5

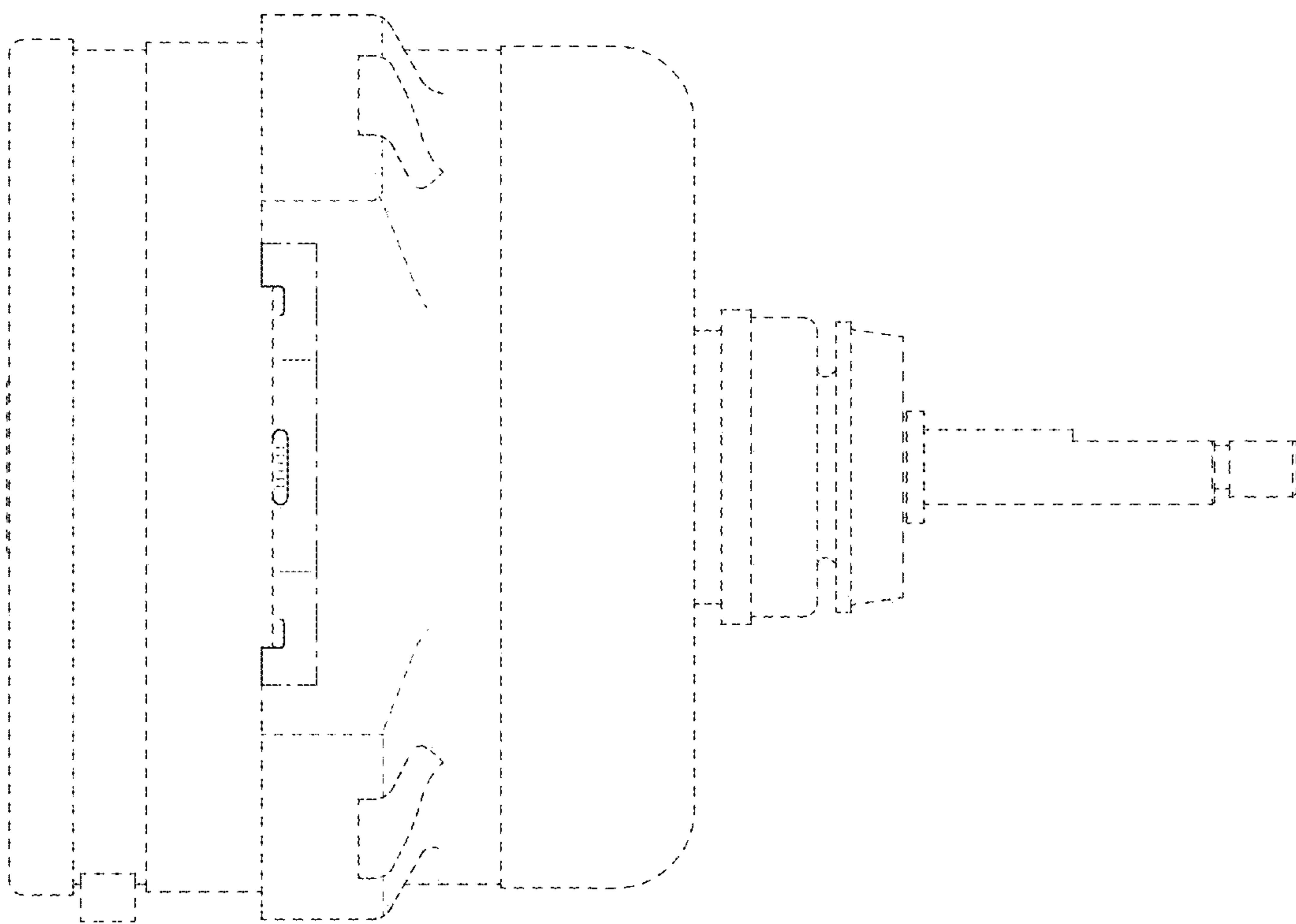

FIG. 6

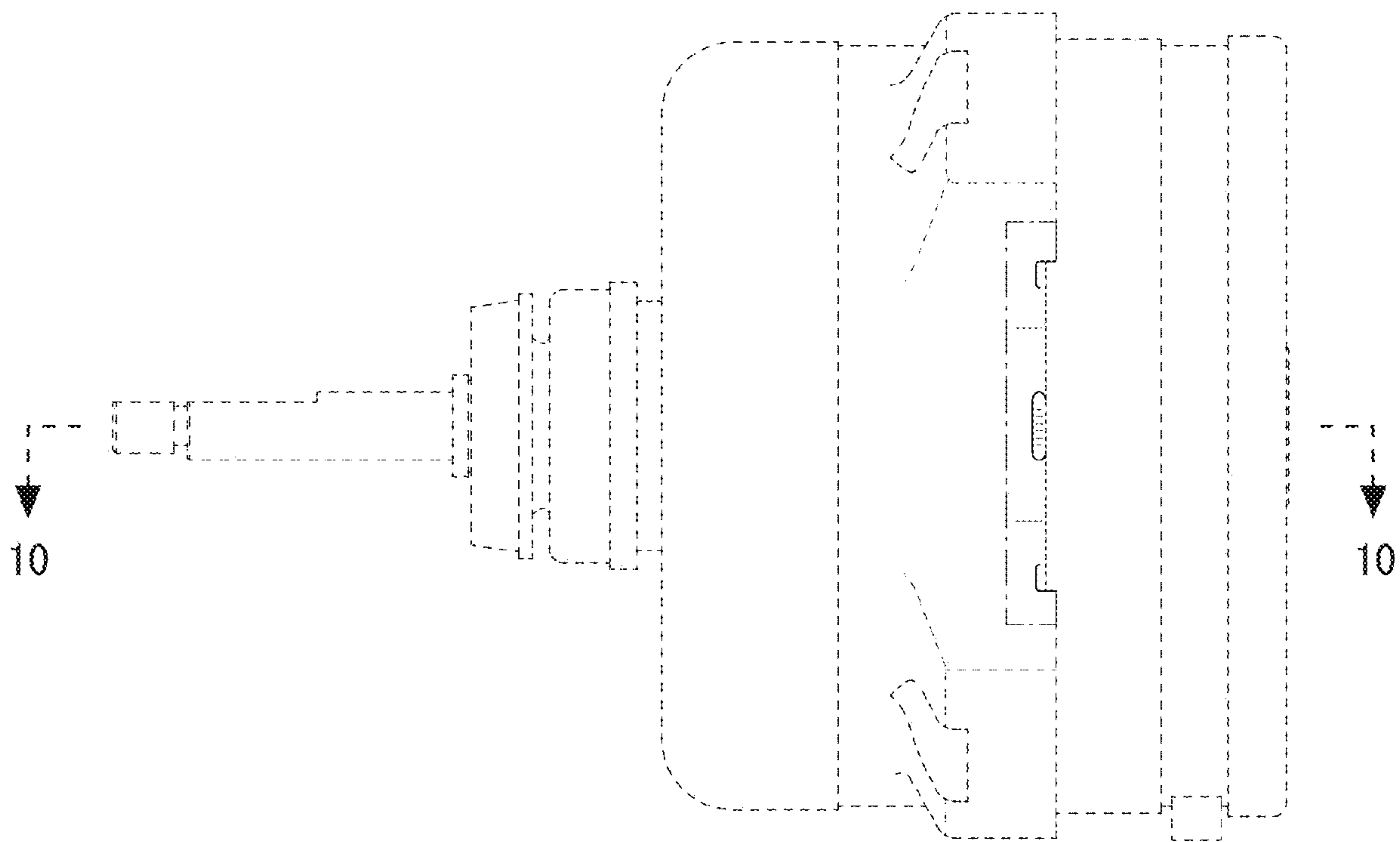



FIG. 7

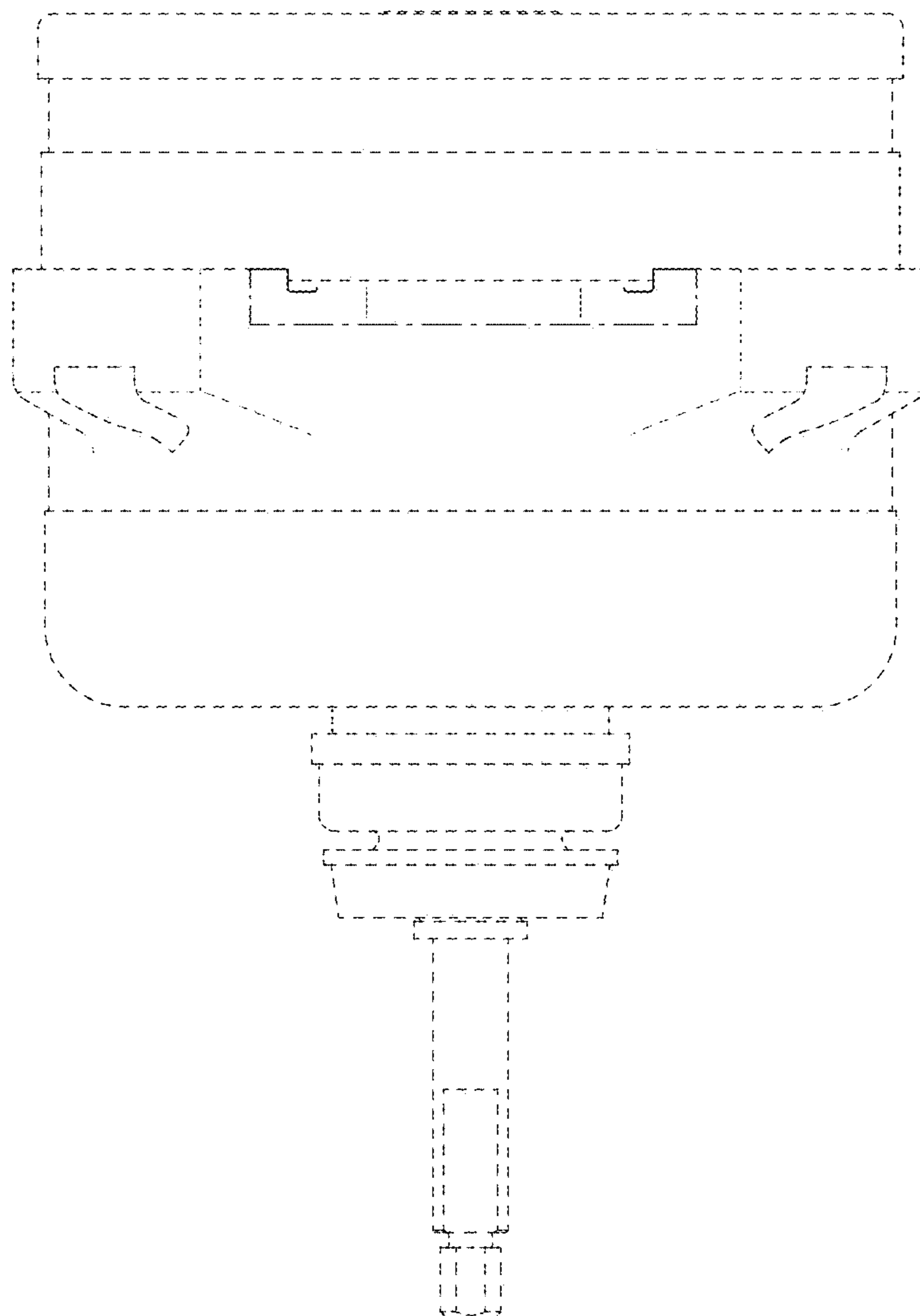

FIG. 8

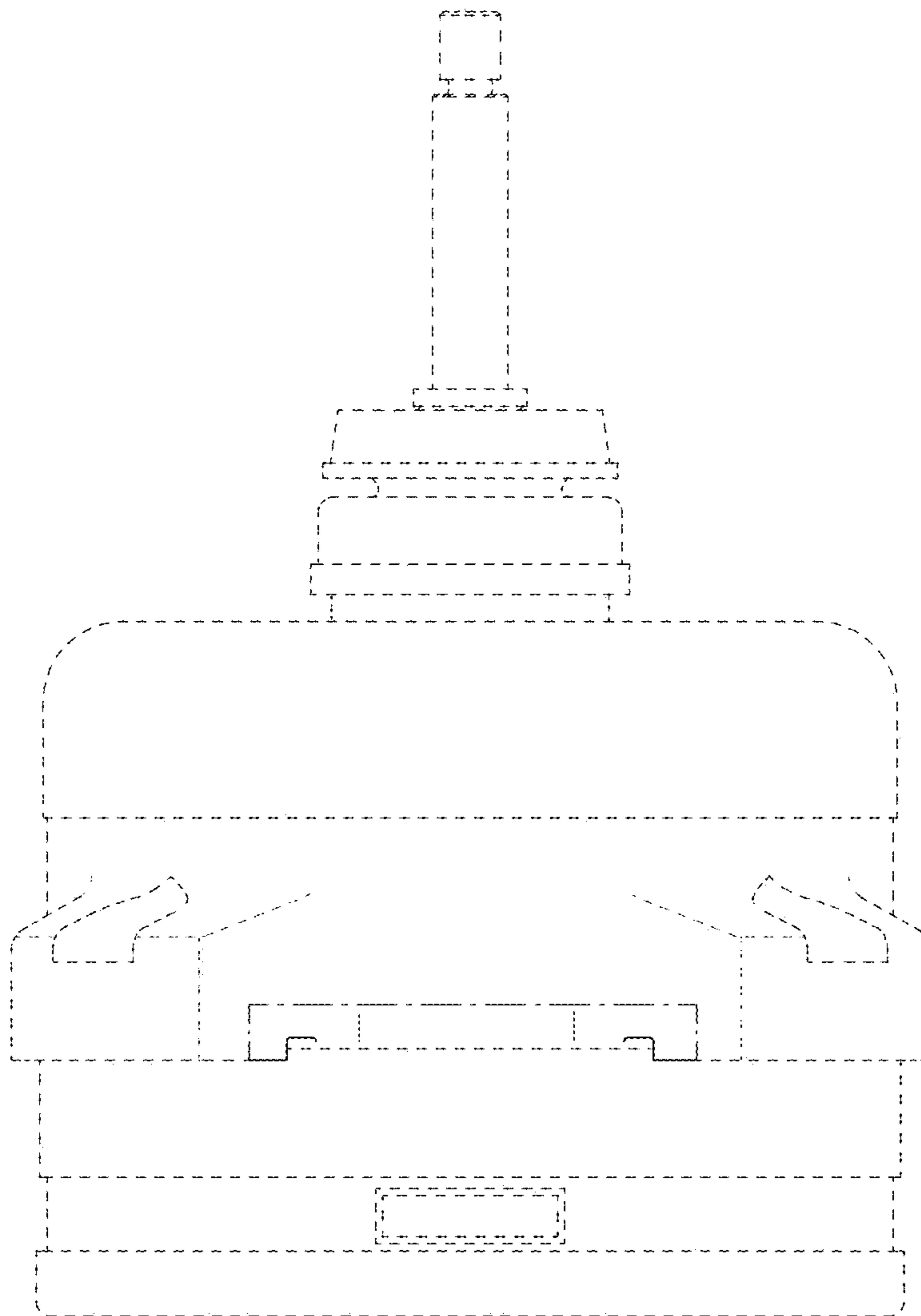

FIG. 9

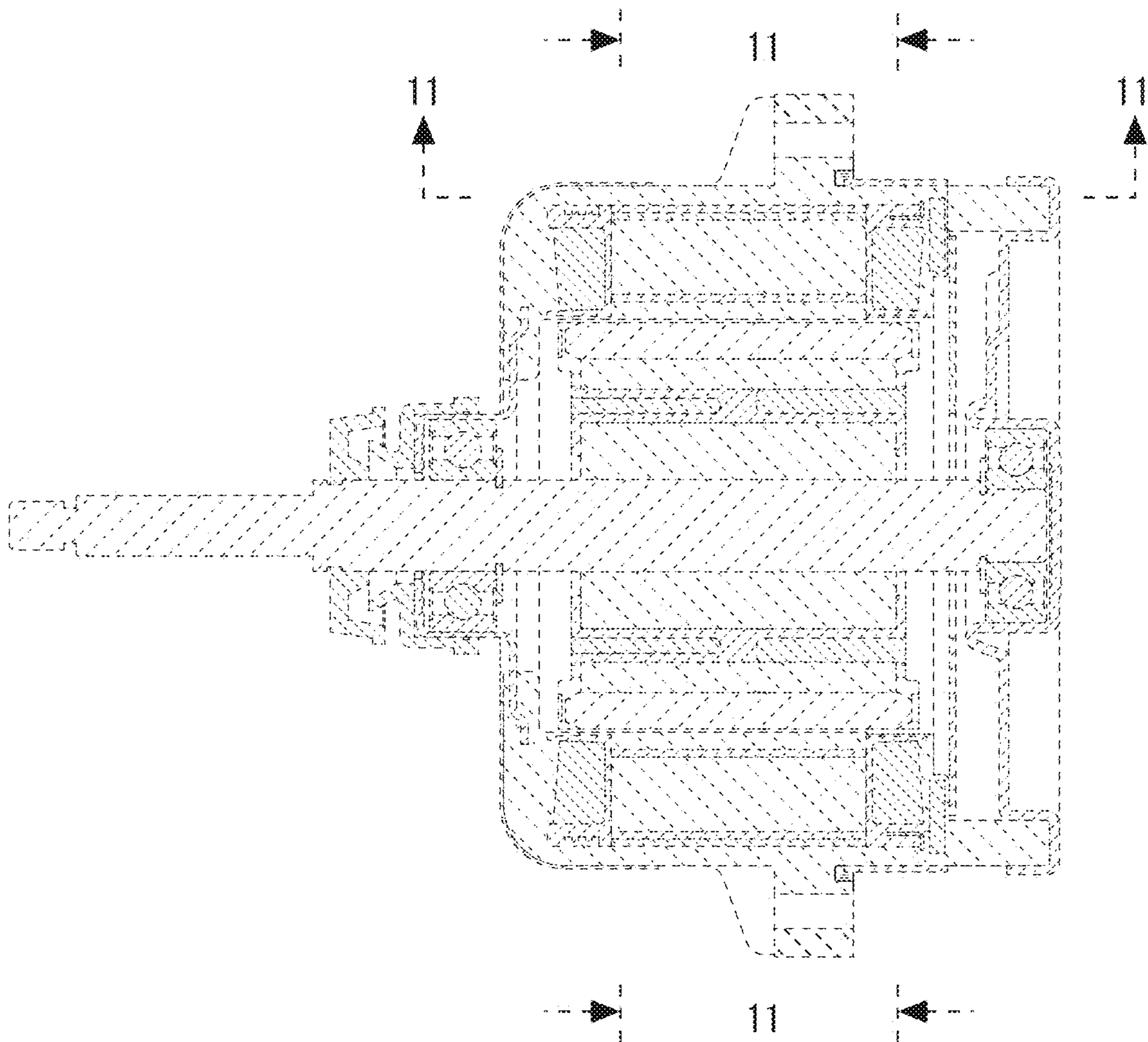

FIG. 10

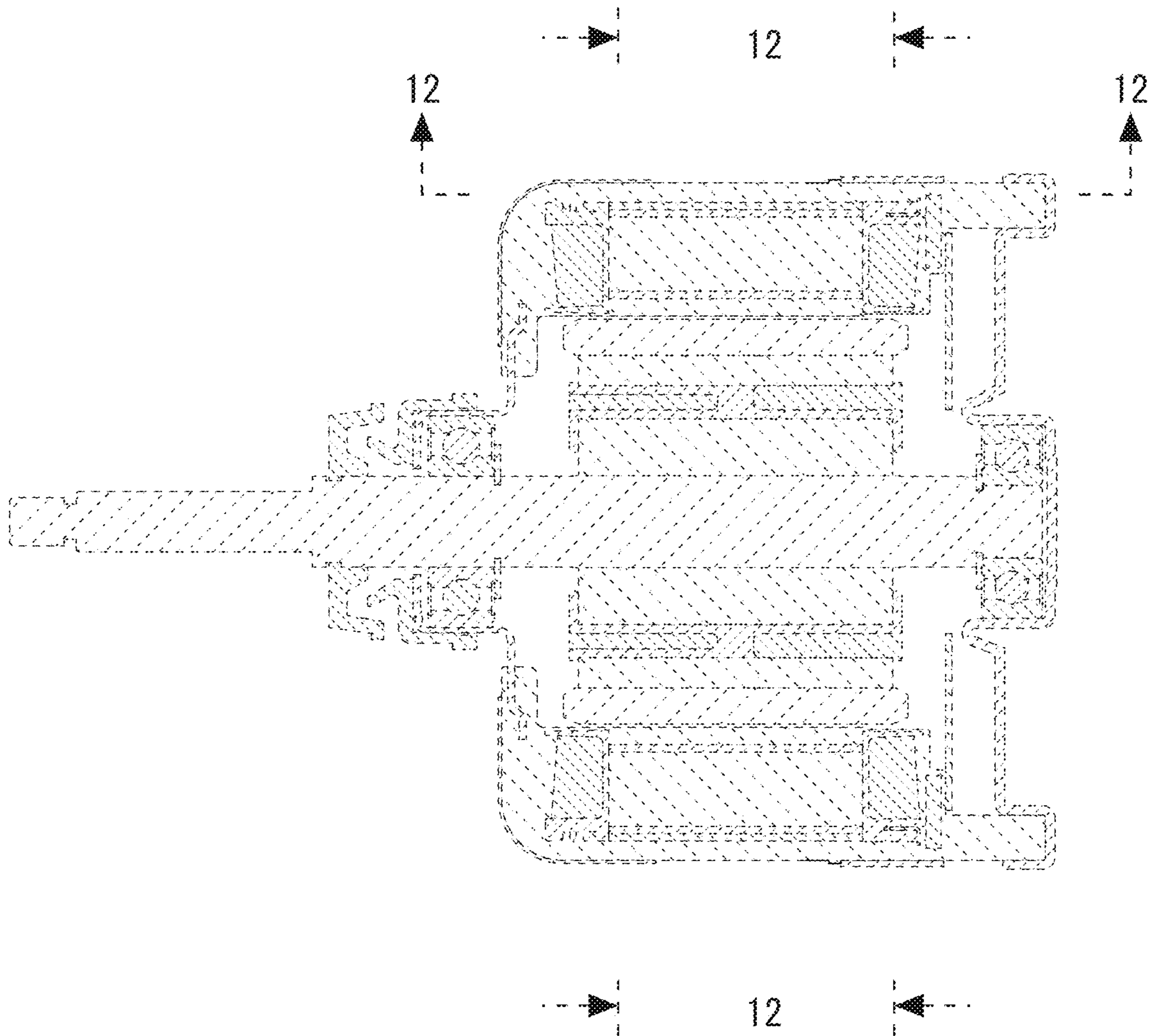

FIG. 11

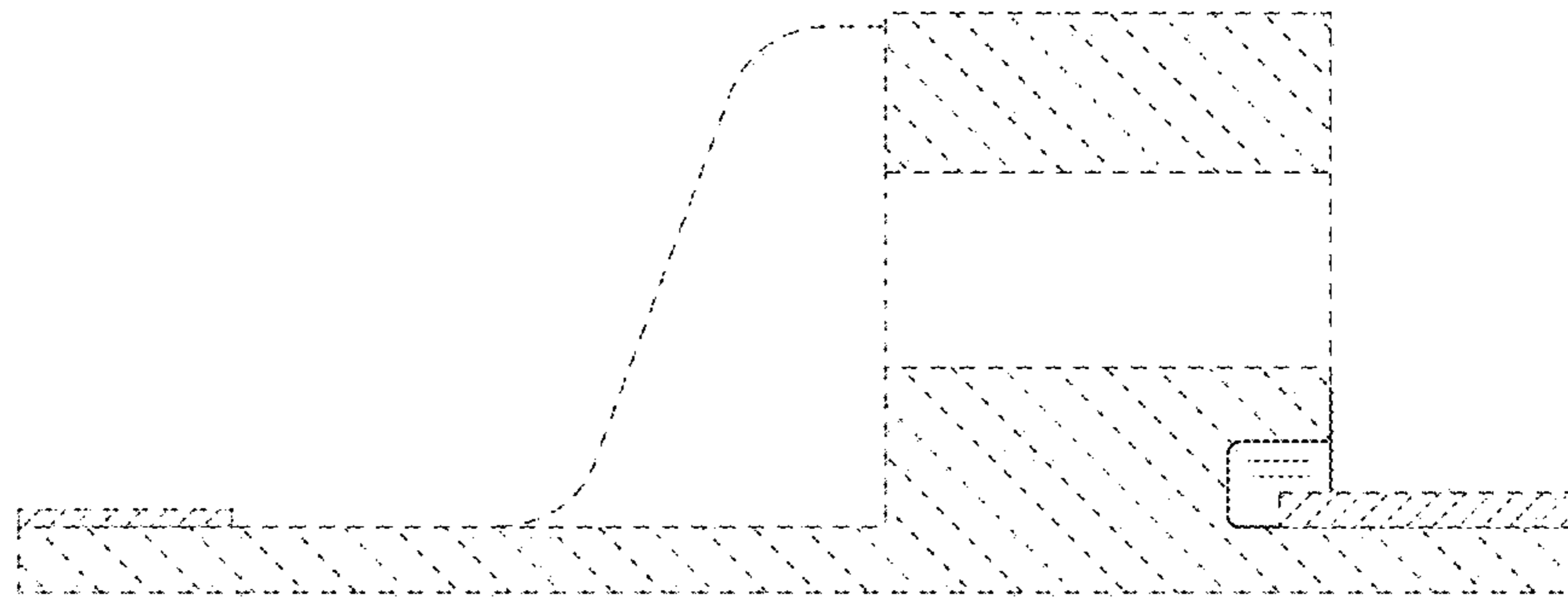

FIG. 12

