



US00D913907S

(12) **United States Design Patent**
Lachendro et al.

(10) **Patent No.:** **US D913,907 S**
(45) **Date of Patent:** **** Mar. 23, 2021**

- (54) **CARGO POD FAIRING**
- (71) Applicant: **Raisbeck Engineering, Inc.**, Seattle, WA (US)
- (72) Inventors: **Nathan Lachendro**, Seattle, WA (US);
Davud Kasparov, Seattle, WA (US);
M. Joel Shaw, Seattle, WA (US);
Aaron Jo-Nes, Seattle, WA (US);
Blaine Whitcomb, Seattle, WA (US)
- (73) Assignee: **Raisbeck Engineering, Inc.**, Seattle, WA (US)
- (**) Term: **15 Years**
- (21) Appl. No.: **29/720,964**
- (22) Filed: **Jan. 16, 2020**
- (51) **LOC (13) Cl.** **12-07**
- (52) **U.S. Cl.**
USPC **D12/345**
- (58) **Field of Classification Search**
USPC D12/1, 2, 3, 4, 16.1, 174, 319-345;
D21/436-455; D13/109
CPC B64C 29/0033; B64C 2201/021; B64C
29/02; B64C 2201/088; B64C 2201/104;
B64C 2201/141
See application file for complete search history.

(56) **References Cited**

U.S. PATENT DOCUMENTS

D374,418 S *	10/1996	Griffin	D12/181
D375,925 S *	11/1996	Griffin	D12/181
D679,638 S *	4/2013	Harvey	D12/181
D719,885 S *	12/2014	Conway	D12/195
D758,950 S *	6/2016	Scooler	D12/345
9,650,154 B2 *	5/2017	Cook	B64D 47/04
9,926,069 B2 *	3/2018	Havar	B64C 9/16
D854,470 S *	7/2019	Haws	D12/181
10,343,764 B2 *	7/2019	Hensley	B64C 25/001

10,518,850 B2 *	12/2019	Page	G01S 7/521
2009/0127403 A1 *	5/2009	Perez-Sanchez	B64C 9/16 244/213
2009/0184200 A1 *	7/2009	Lin	B32B 15/20 244/1 N
2016/0221670 A1 *	8/2016	Robinson	B64C 35/008

* cited by examiner

Primary Examiner — John A Voytek
(74) *Attorney, Agent, or Firm* — Christensen O'Connor Johnson Kindness, PLLC

(57) **CLAIM**

The ornamental design for the cargo pod fairing, as shown and described.

DESCRIPTION

FIG. 1 is of a cargo pod fairing shown in an environment of use, in accordance with the present design;
 FIG. 2 is a lower-front-left perspective view of the cargo pod fairing shown in FIG. 1, removed from an environment of use for clarity of disclosure;
 FIG. 3 is an upper-front-left perspective view of the cargo pod fairing shown in FIG. 2;
 FIG. 4 is a front view of the cargo pod fairing shown in FIG. 2;
 FIG. 5 is a back view of the cargo pod fairing shown in FIG. 2;
 FIG. 6 is a top plan view of the cargo pod fairing shown in FIG. 2;
 FIG. 7 is a bottom plan view of the cargo pod fairing shown in FIG. 2;
 FIG. 8 is a right side view of the cargo pod fairing shown in FIG. 2; and,
 FIG. 9 is a left side view of the cargo pod fairing shown in FIG. 2.
 The broken line showing of an aircraft is for the purpose of illustrating environmental structure and forms no part of the claimed design.

1 Claim, 8 Drawing Sheets

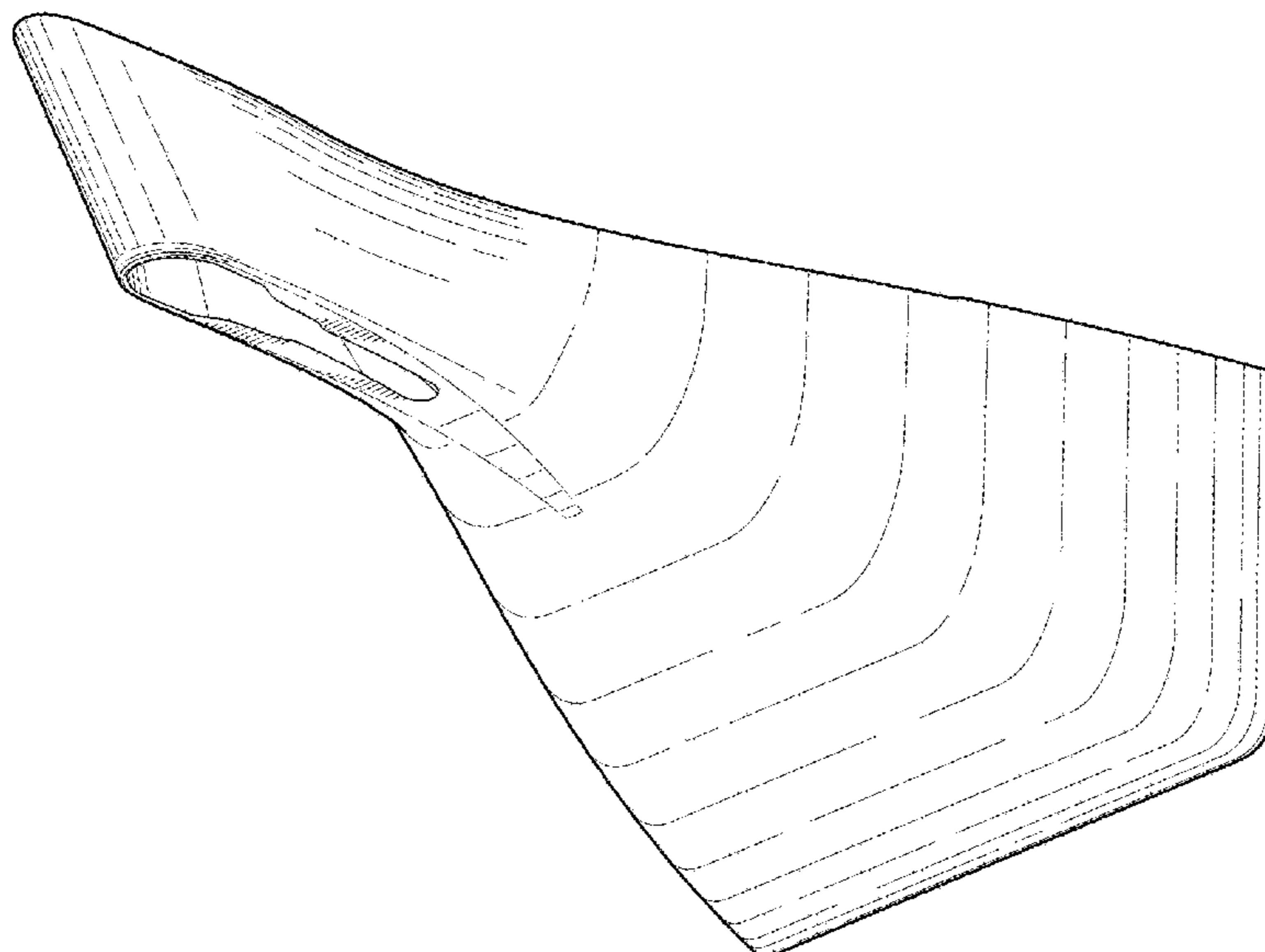

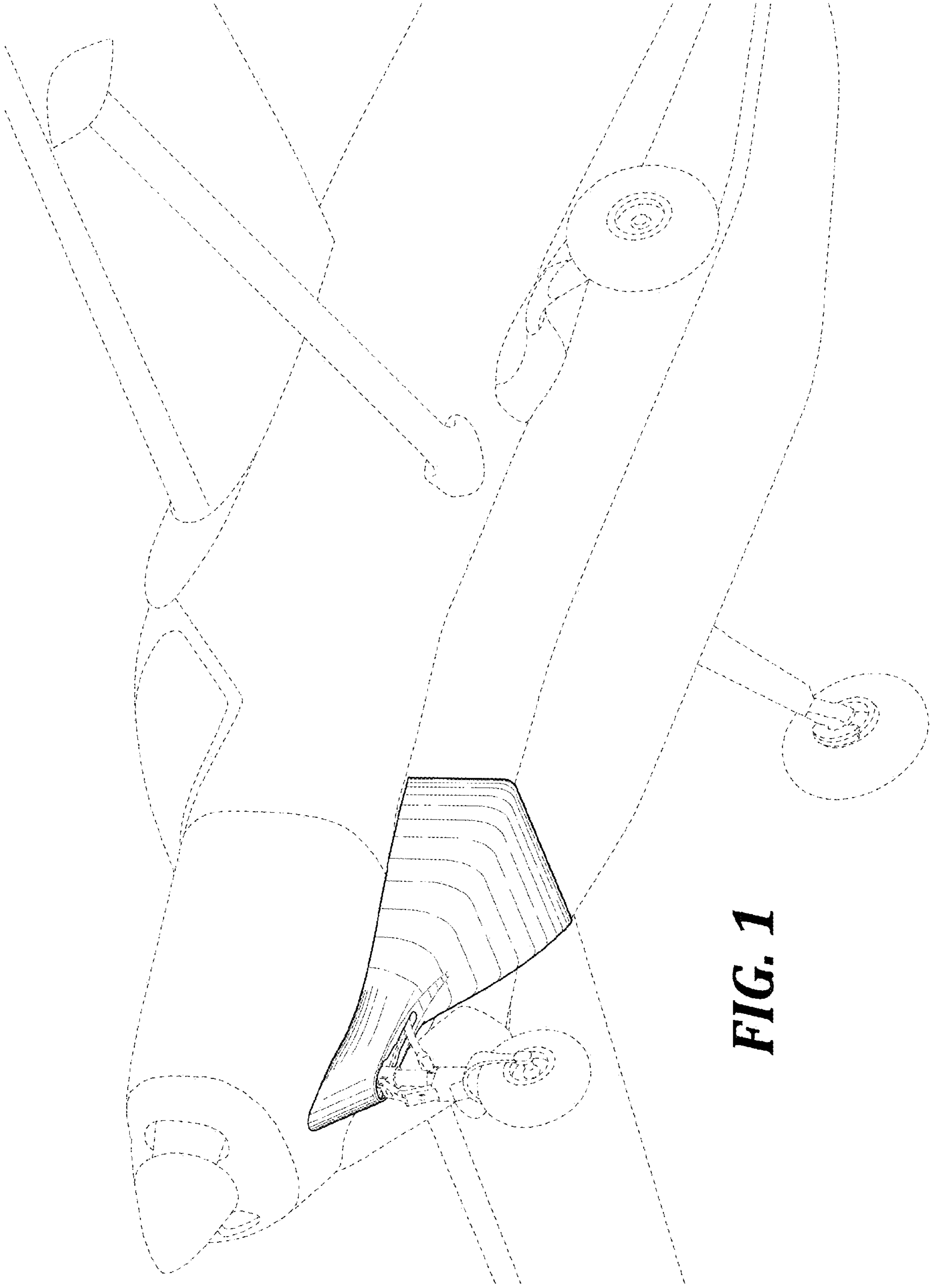

FIG. 1

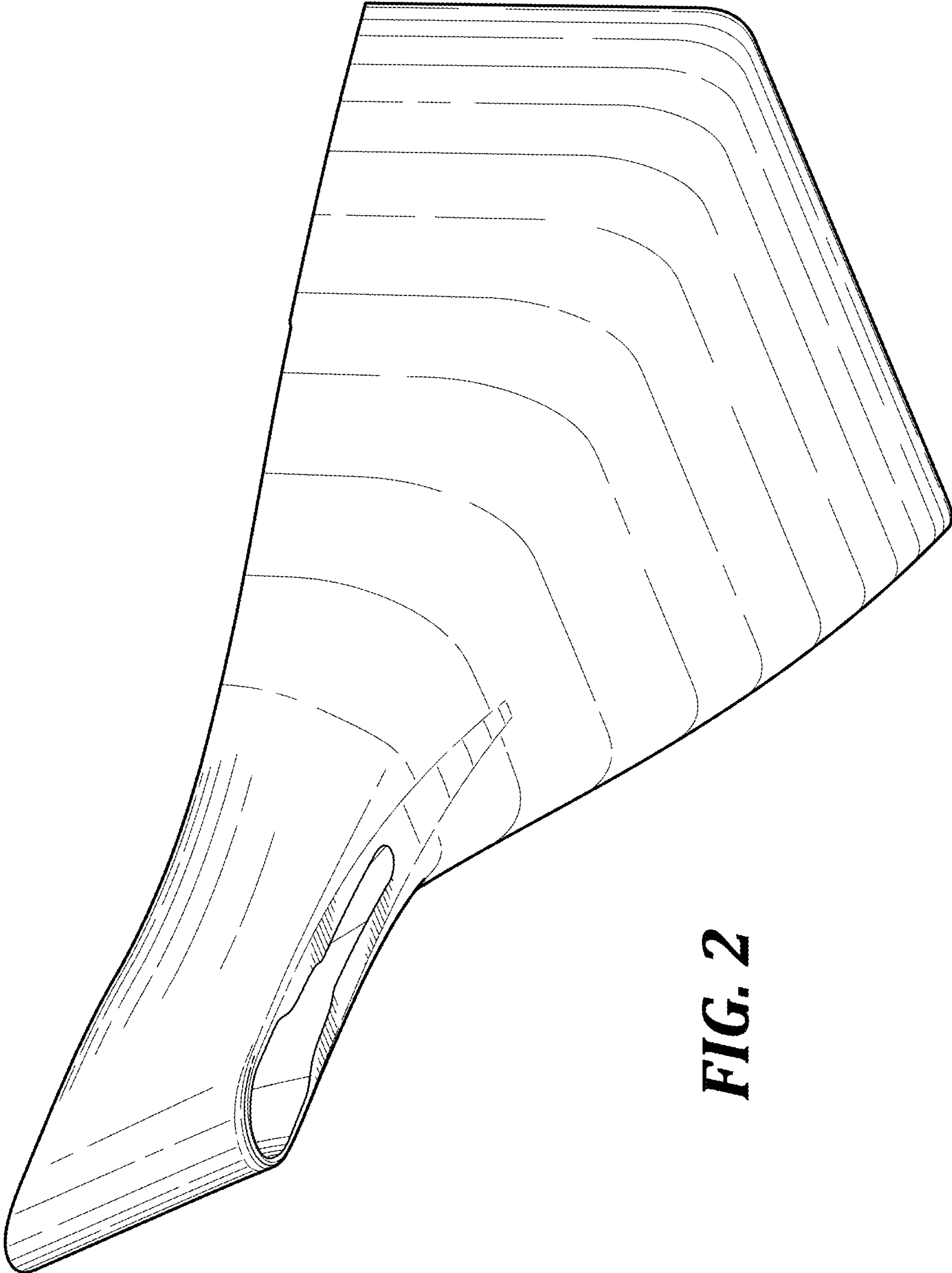

FIG. 2

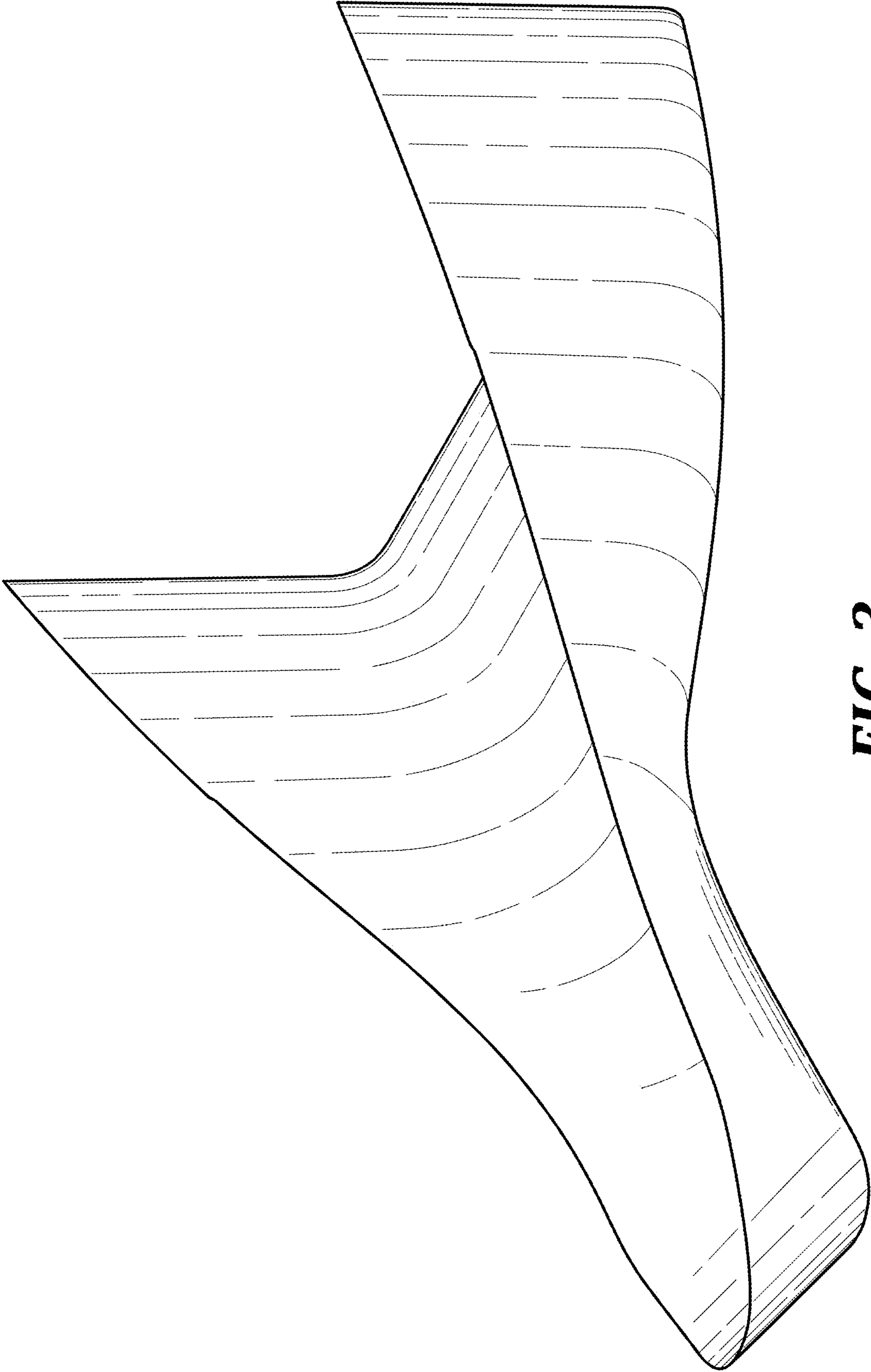

FIG. 3

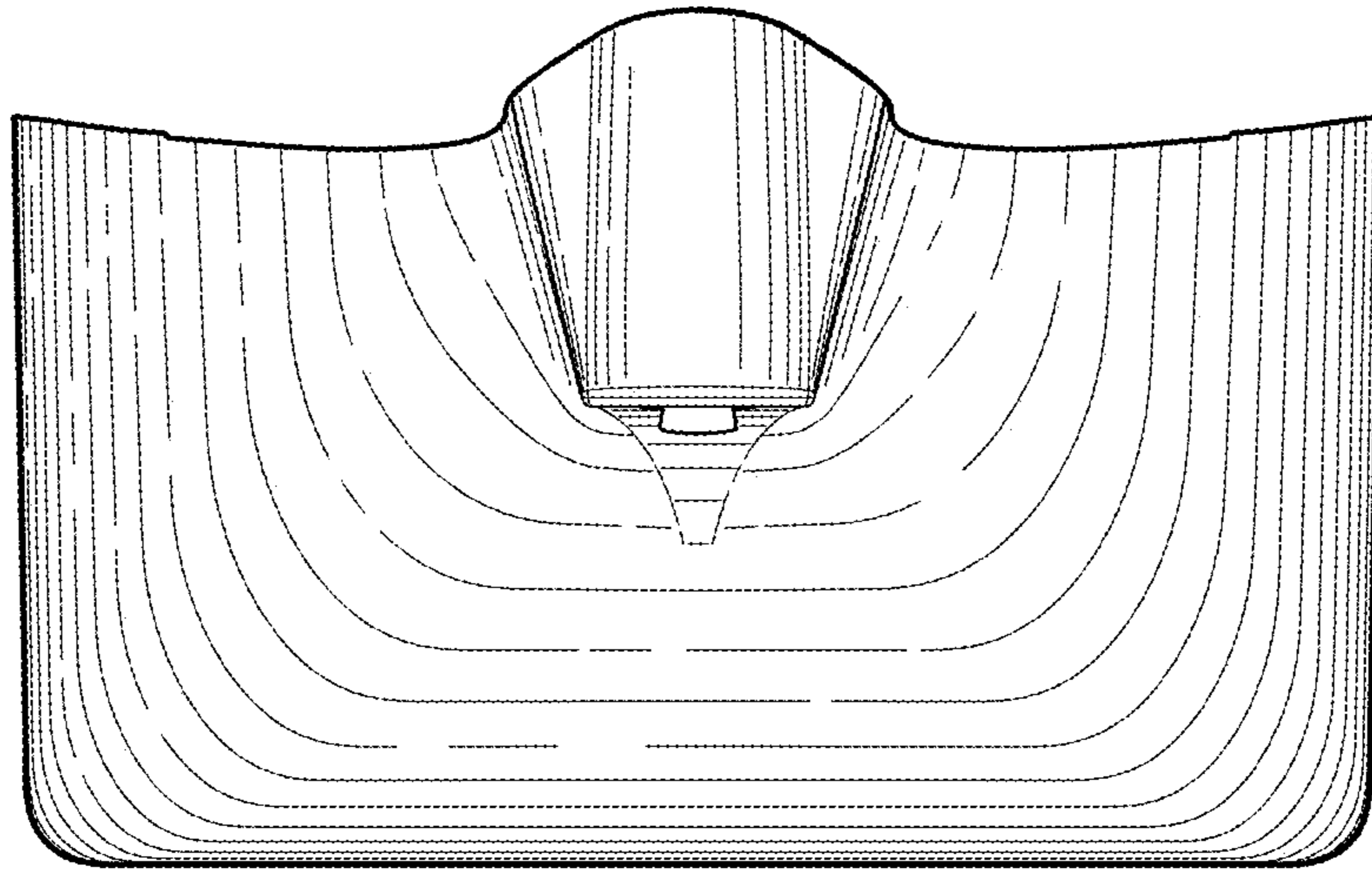

FIG. 4

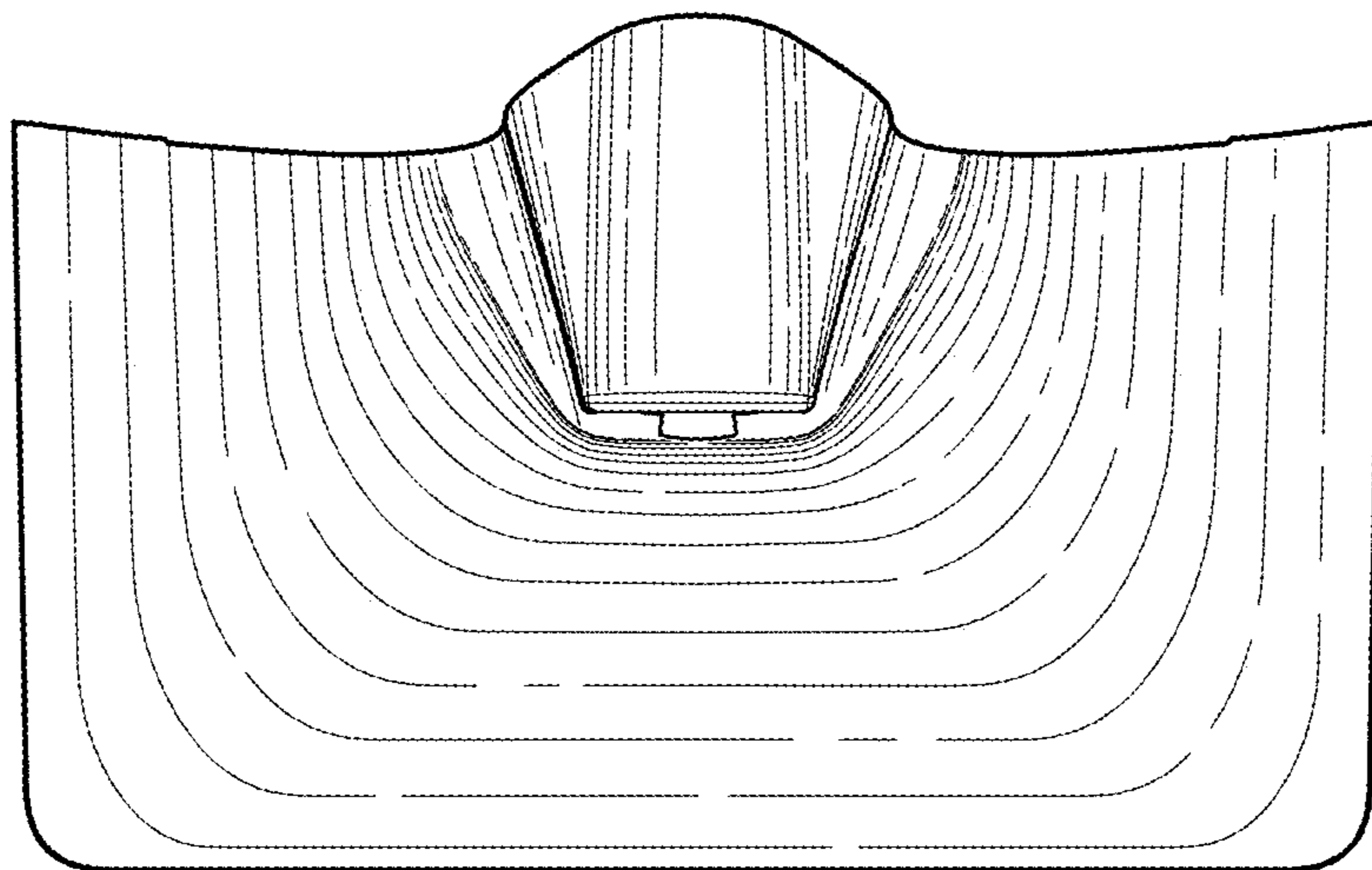

FIG. 5

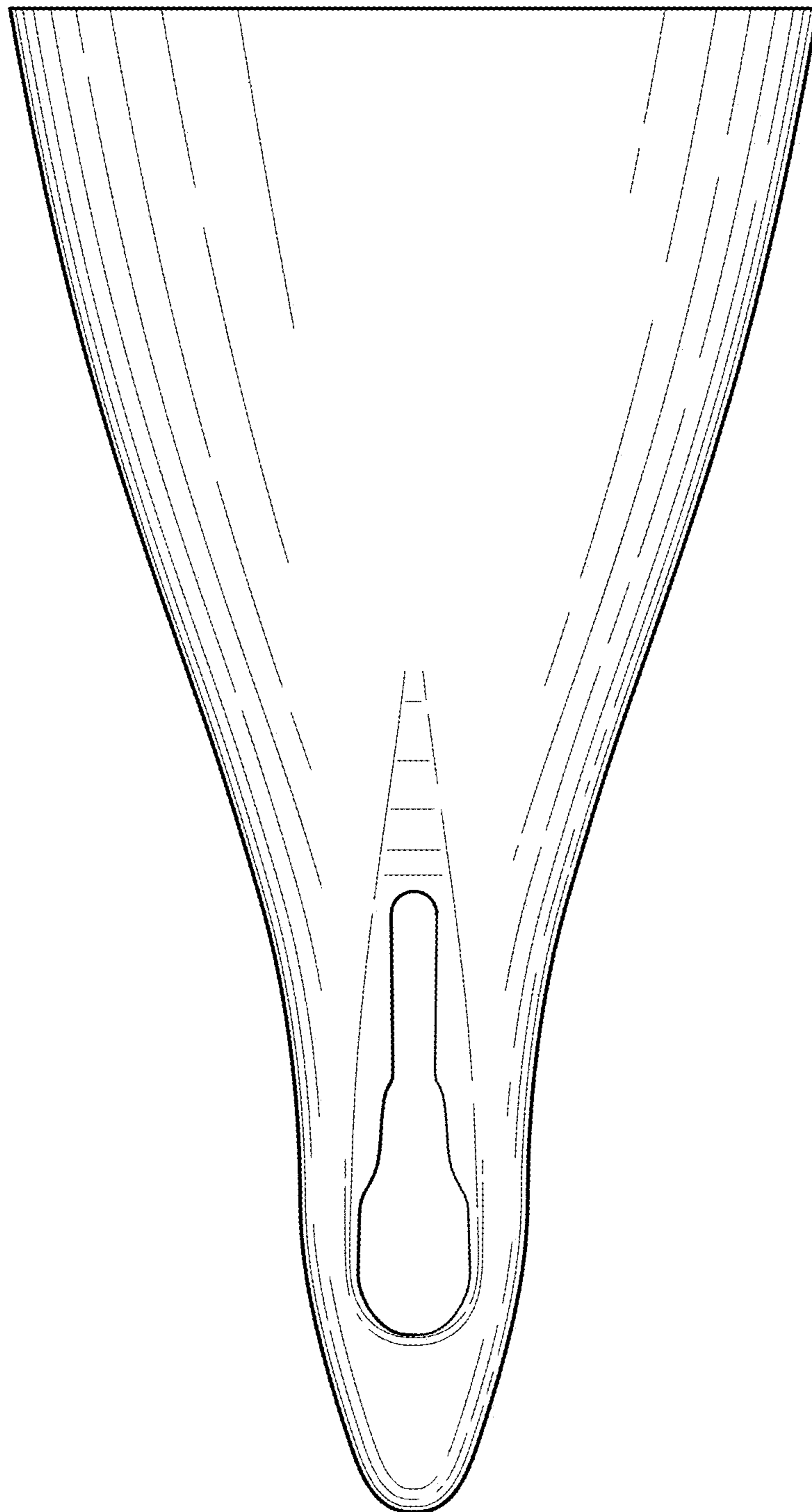

FIG. 6

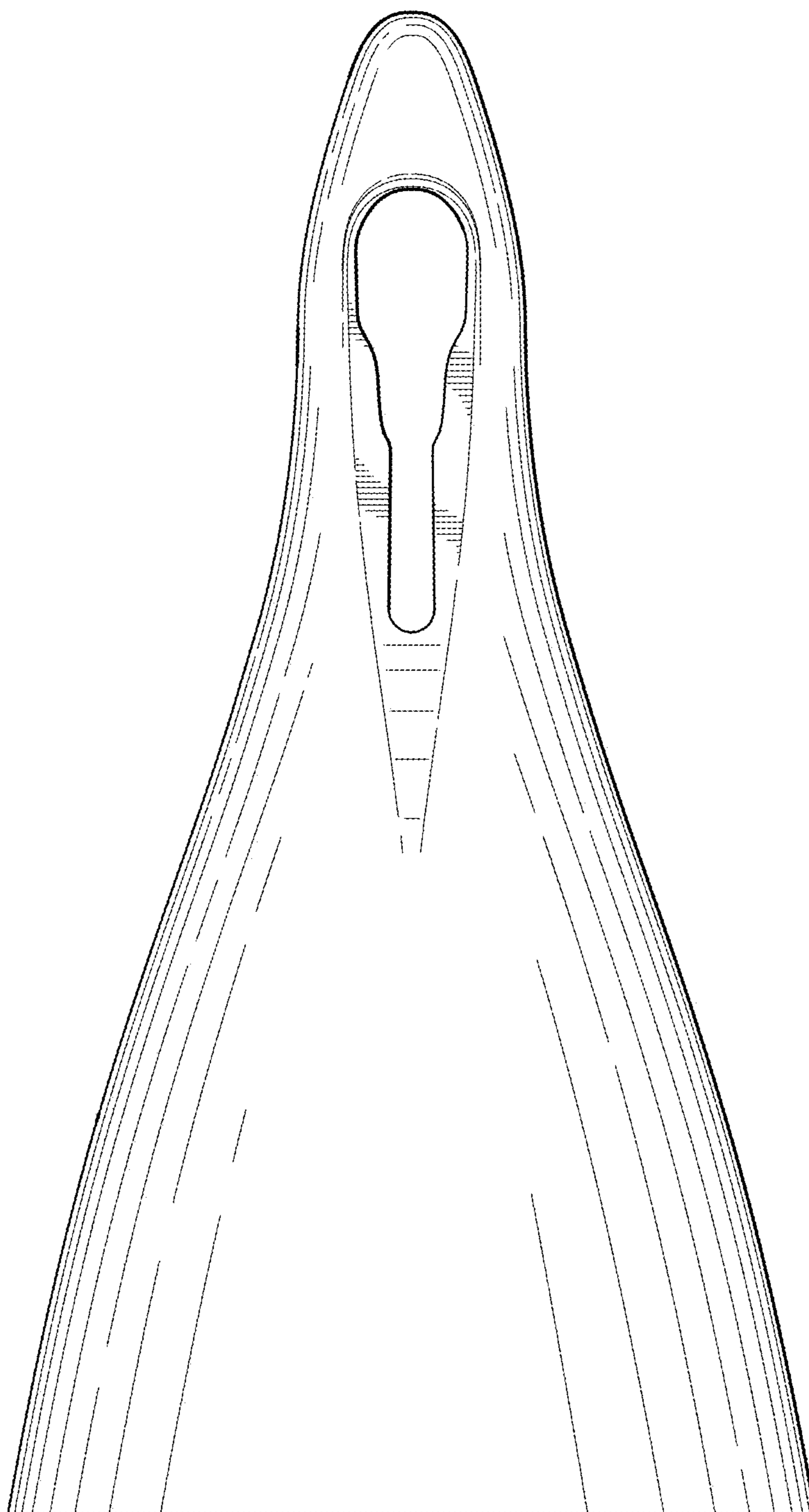

FIG. 7

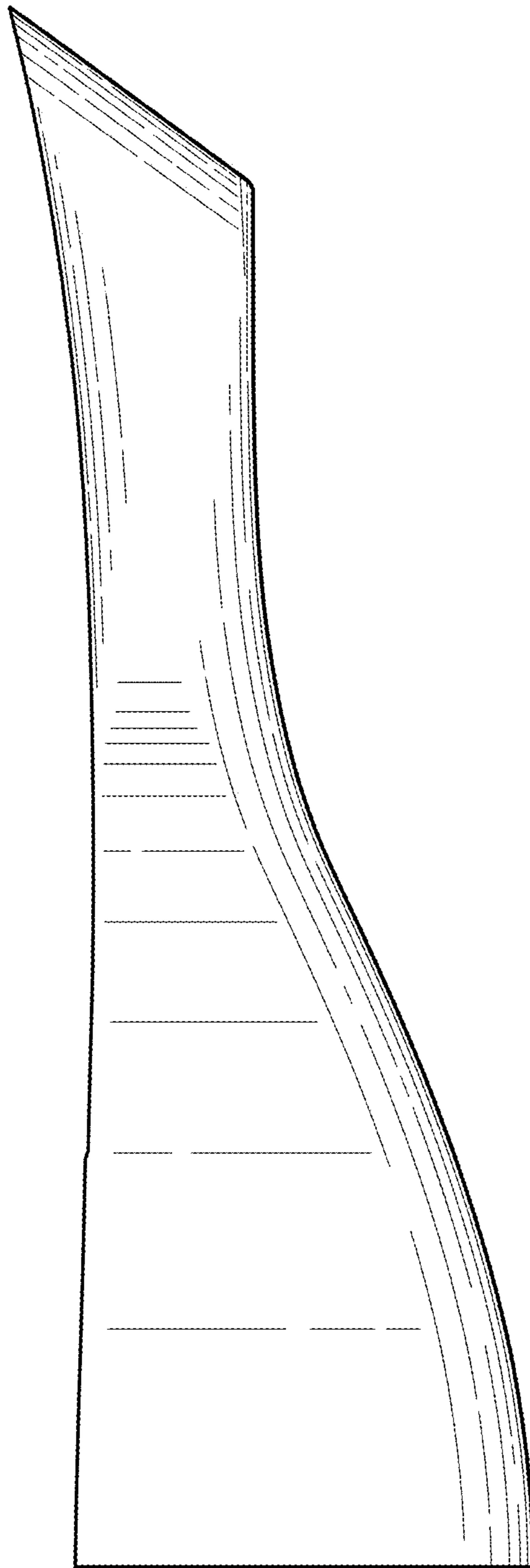

FIG. 8

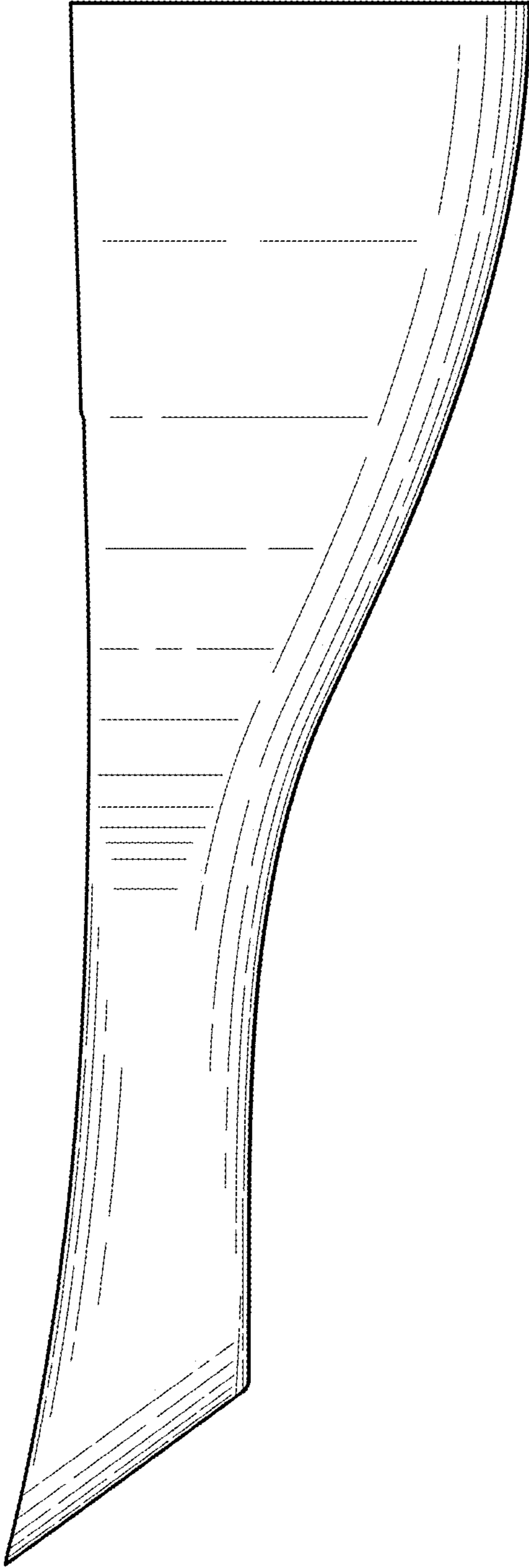

FIG. 9