



US00D913871S

(12) **United States Design Patent** (10) **Patent No.:** **US D913,871 S**  
**Tovey et al.** (45) **Date of Patent:** **\*\* Mar. 23, 2021**

(54) **REAR END PORTION OF A VEHICLE**  
(71) Applicant: **Jaguar Land Rover Limited**, Whitley  
Coventry (GB)  
(72) Inventors: **Simon Tovey**, Whitley Coventry (GB);  
**Matthew Beaven**, Whitley Coventry  
(GB)  
(73) Assignee: **JAGUAR LAND ROVER LIMITED**,  
Whitley Coventry (GB)

D725,007 S \* 3/2015 Beaven ..... D12/164  
D731,922 S \* 6/2015 Beaven ..... D12/91  
D739,305 S \* 9/2015 Gunnarson ..... D12/91  
D749,996 S \* 2/2016 Henstridge ..... D12/164  
D783,469 S \* 4/2017 Patel ..... D12/164  
D784,856 S \* 4/2017 Hatton ..... D12/91  
D807,788 S \* 1/2018 Hatton ..... D12/91  
D813,100 S \* 3/2018 Hatton ..... D12/92  
D839,142 S \* 1/2019 Beaven ..... D12/164  
D841,518 S \* 2/2019 Tovey ..... D12/91  
D863,146 S \* 10/2019 Frascella ..... D12/164  
D881,082 S \* 4/2020 Tovey ..... D12/164

(\*\*) Term: **15 Years**

\* cited by examiner

(21) Appl. No.: **29/727,872**

*Primary Examiner* — Melody N Brown

(22) Filed: **Mar. 13, 2020**

(74) *Attorney, Agent, or Firm* — Reising Ethington P.C.

**Related U.S. Application Data**

(62) Division of application No. 29/679,527, filed on Feb.  
7, 2019, now Pat. No. Des. 881,082, which is a  
division of application No. 29/624,949, filed on Nov.  
6, 2017, now Pat. No. Des. 841,518.

(57) **CLAIM**

The ornamental design for a rear end portion of a vehicle, as  
shown and described.

(30) **Foreign Application Priority Data**

May 11, 2017 (EM) ..... 003996917

(51) **LOC (13) Cl.** ..... **12-16**

(52) **U.S. Cl.**  
USPC ..... **D12/164**

(58) **Field of Classification Search**  
USPC ..... D12/86, 90–92, 88, 164; D21/424, 433,  
D21/434, 533; 296/181.1–181.5, 183.1  
CPC ..... B62D 25/00; B62D 25/06; B62D 33/00;  
B62D 35/00  
See application file for complete search history.

**DESCRIPTION**

FIG. 1 is a right, front perspective view of a rear end portion  
of a vehicle showing our new design;  
FIG. 2 is a left, front perspective view thereof;  
FIG. 3 is a left, rear perspective view thereof;  
FIG. 4 is a right, rear perspective view thereof;  
FIG. 5 is a front view thereof;  
FIG. 6 is a right side view thereof;  
FIG. 7 is a left side view thereof; and,  
FIG. 8 is a top view thereof.

The portions of the vehicle shown throughout the drawing  
views in a de-emphasized and half-tone form outside the  
broken lines and the broken lines representing the boundary  
and configuration of what is claimed as the design are all for  
environmental and illustrative purposes and form no part of  
the claimed design.

(56) **References Cited**

**U.S. PATENT DOCUMENTS**

D698,697 S \* 2/2014 Winkelmann ..... D12/91  
D719,878 S \* 12/2014 Webber ..... D12/92

**1 Claim, 8 Drawing Sheets**

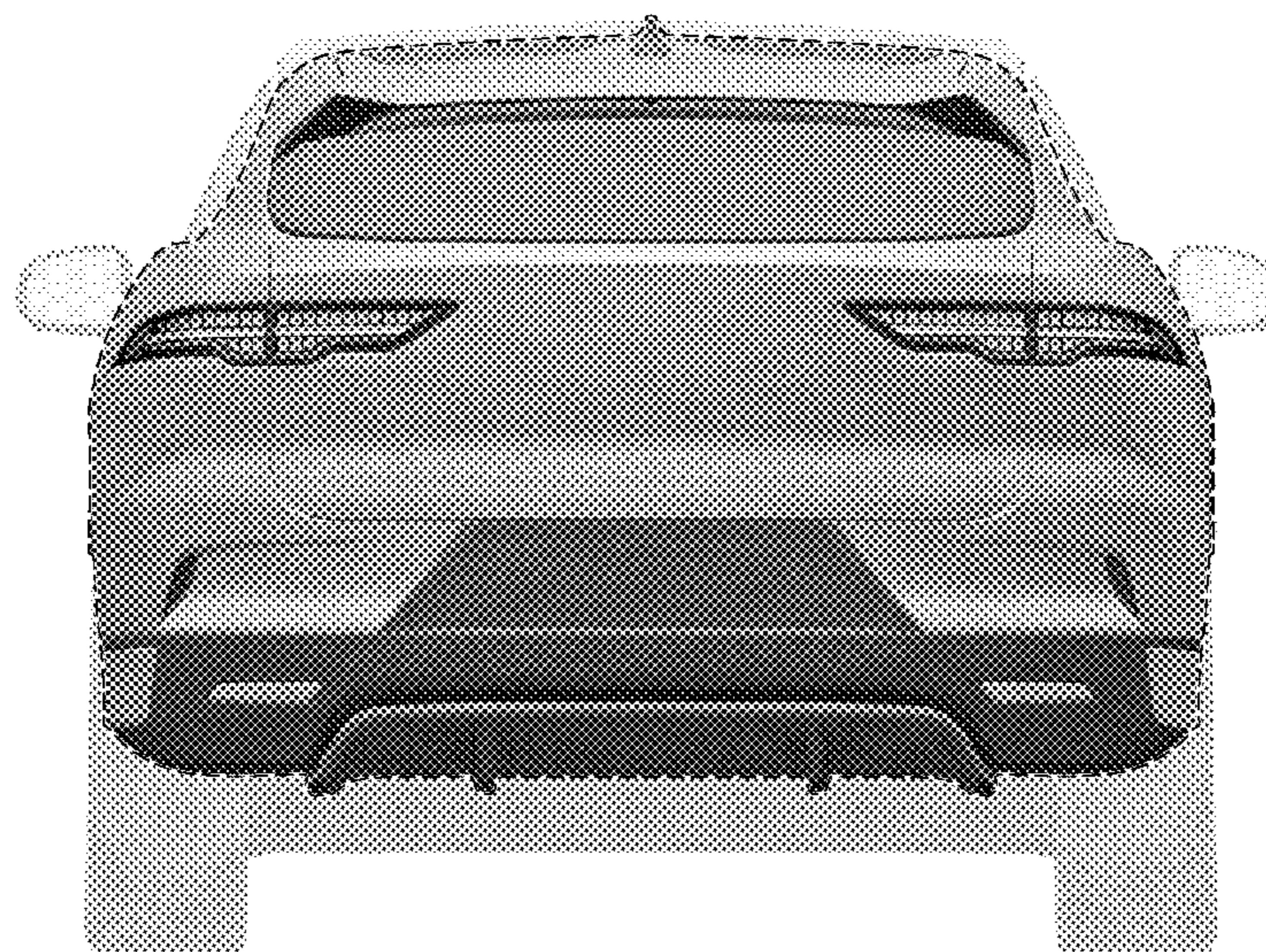



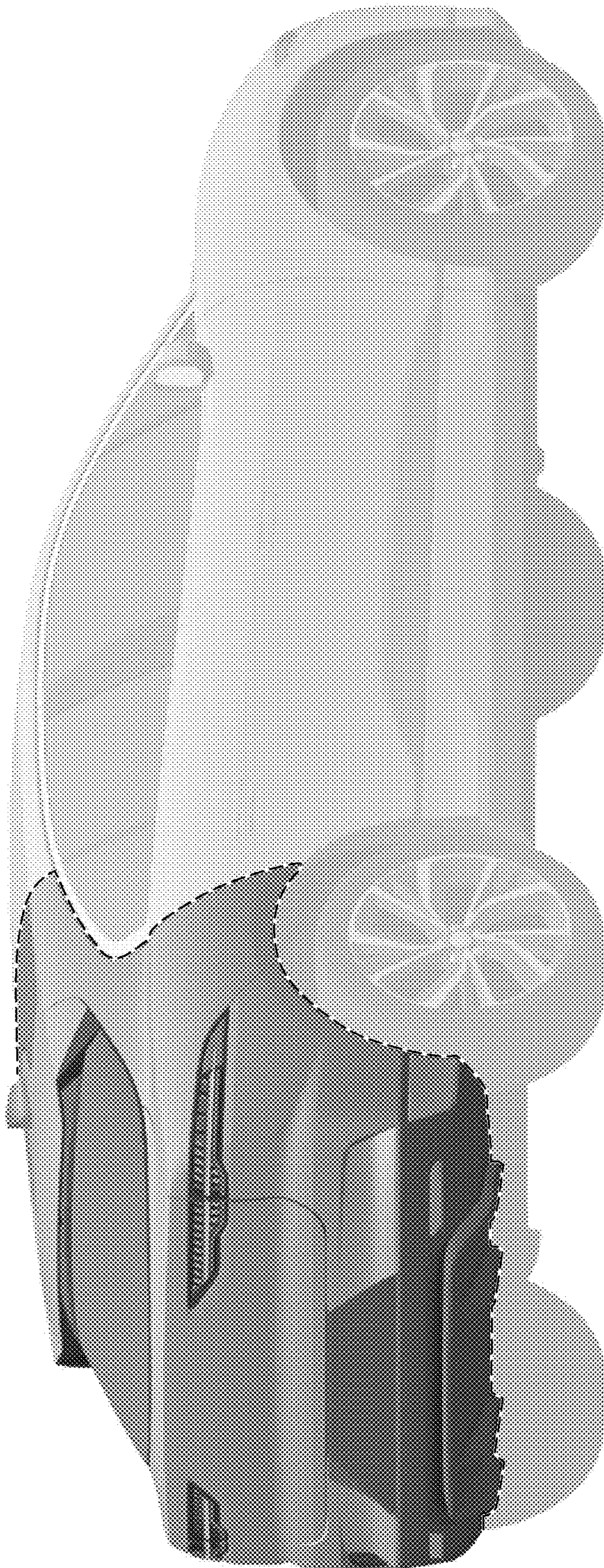

FIG. 1



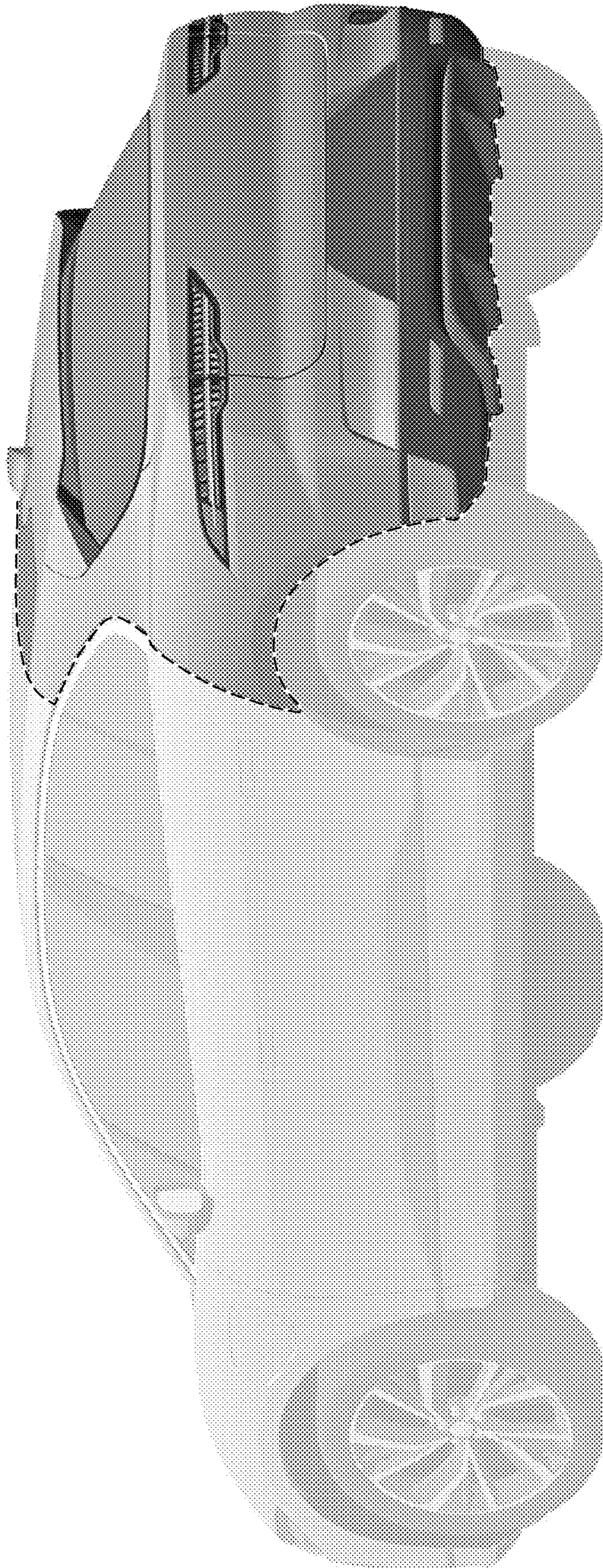

FIG. 2



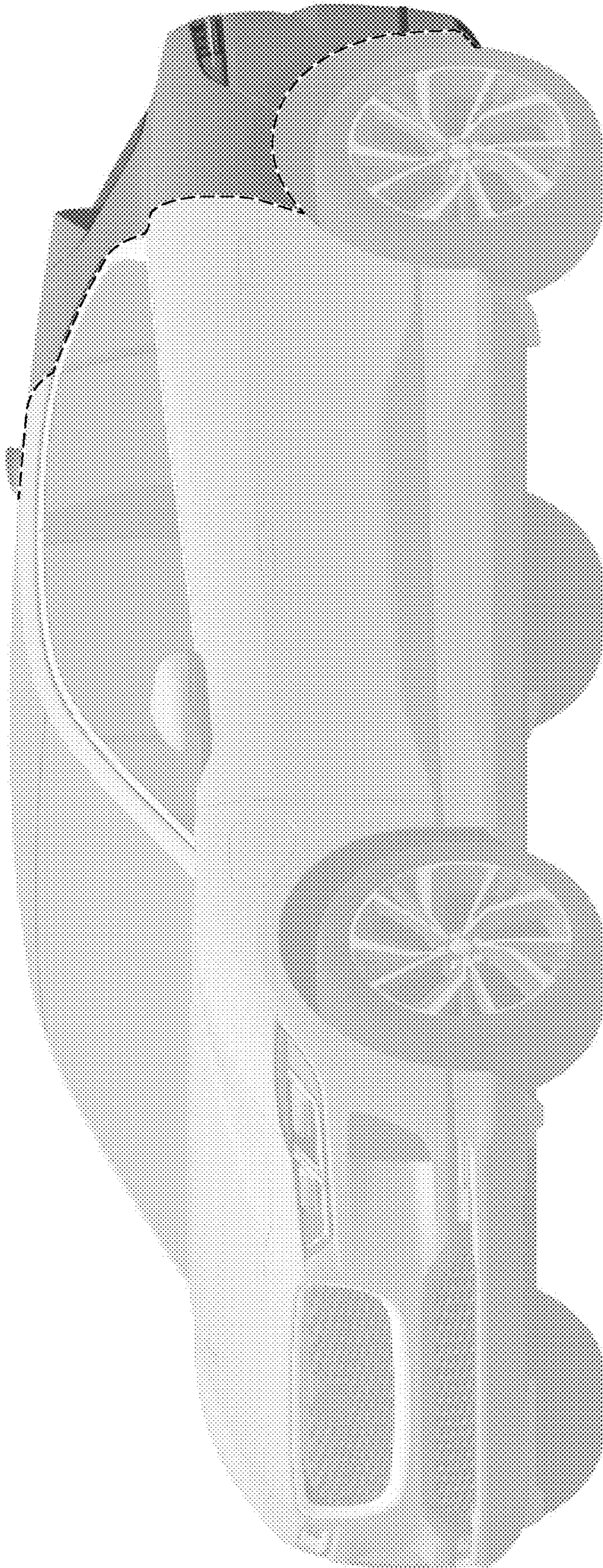

FIG. 3



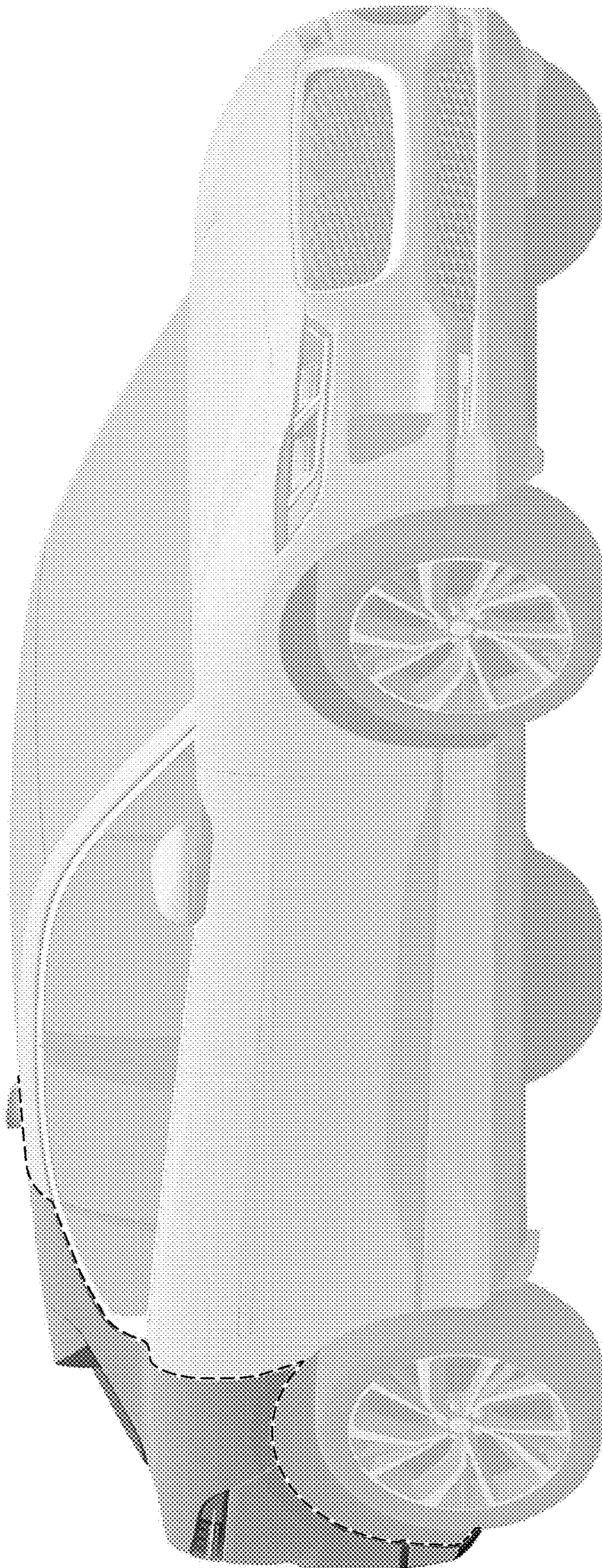

FIG. 4



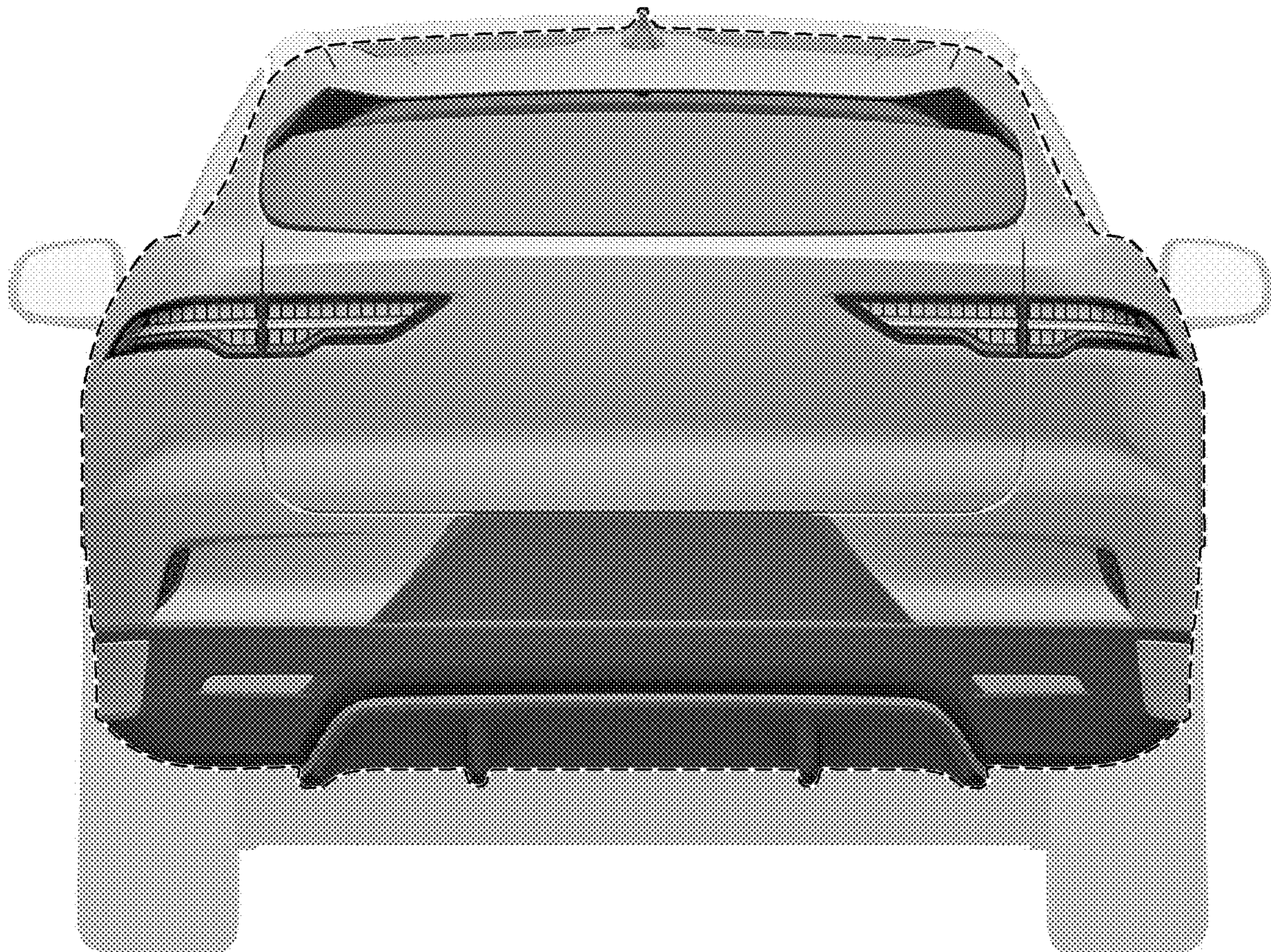

FIG. 5



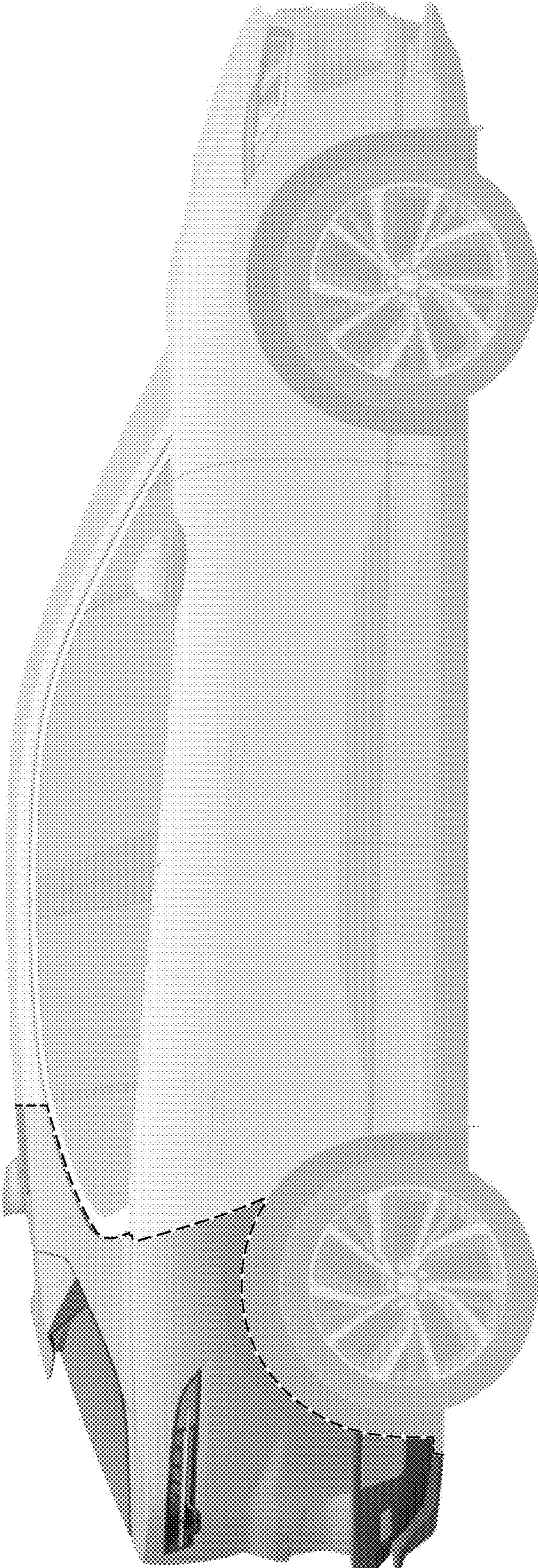

FIG. 6



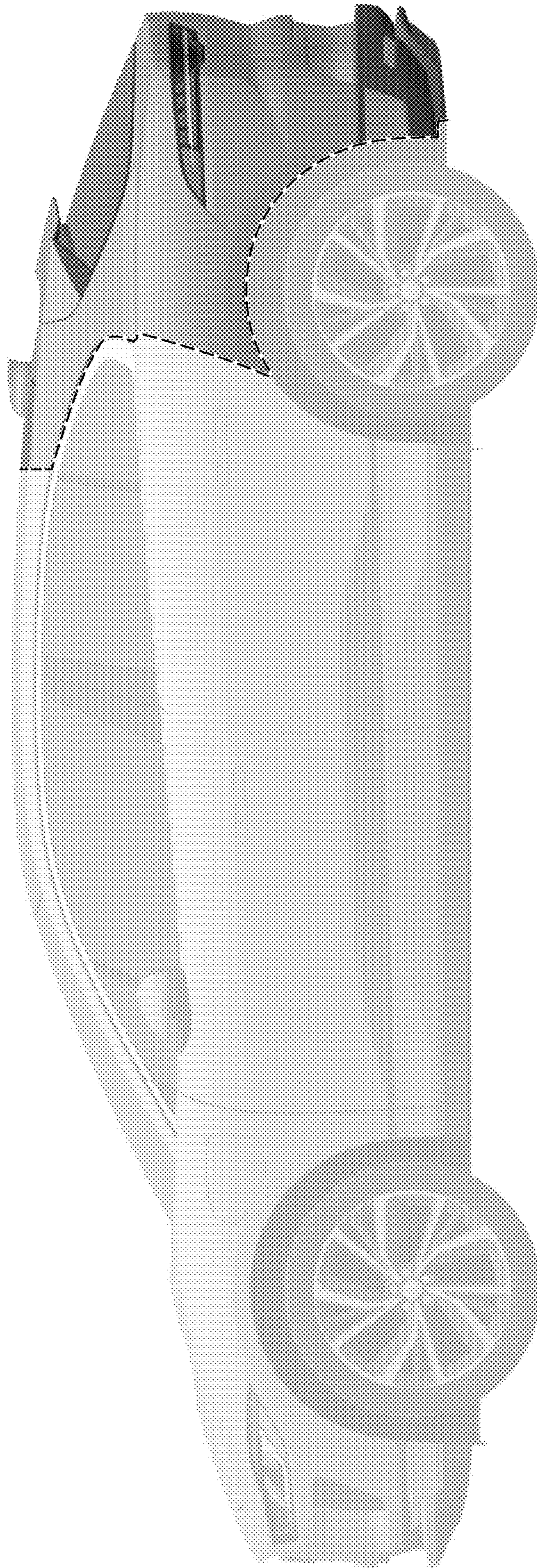

FIG. 7



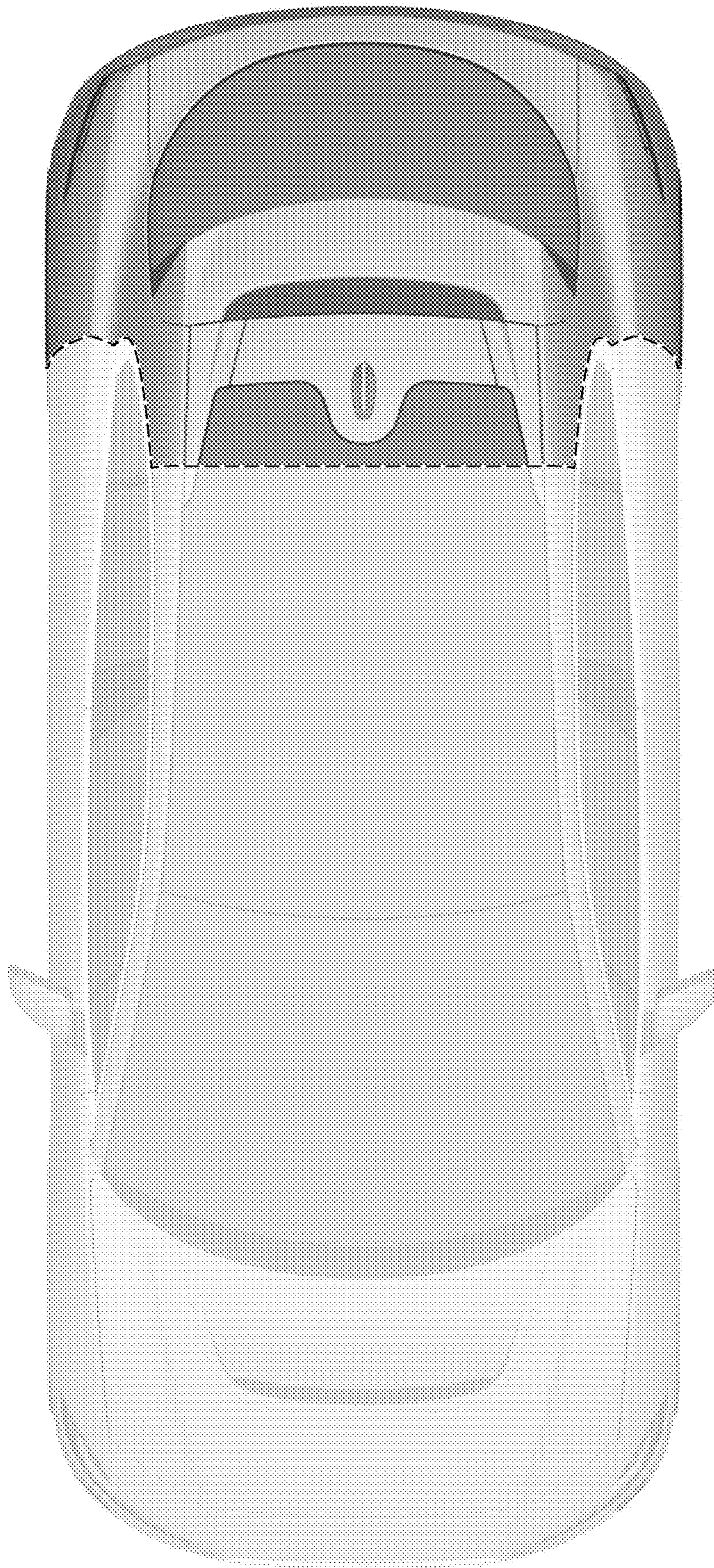

FIG. 8