



US00D913848S

(12) **United States Design Patent**  
**Suehlmann et al.**

(10) **Patent No.:** **US D913,848 S**  
(45) **Date of Patent:** **\*\* Mar. 23, 2021**

(54) **AUTOMOBILE AND/OR REPLICA THEREOF**

(71) Applicant: **ASTON MARTIN LAGONDA LIMITED**, Warwick (GB)

(72) Inventors: **Tobias Suehlmann**, Warwick (GB);  
**Sam Holgate**, Warwick (GB)

(73) Assignee: **ASTON MARTIN LAGONDA LIMITED**

(\*\*) Term: **15 Years**

(21) Appl. No.: **29/699,556**

(22) Filed: **Jul. 26, 2019**

(30) **Foreign Application Priority Data**

Feb. 1, 2019 (EM) ..... 006147724

(51) **LOC (13) Cl.** ..... **12-08**

(52) **U.S. Cl.**  
USPC ..... **D12/88**

(58) **Field of Classification Search**  
USPC ..... D12/86, 90-92, 88; D21/424, 433, 434;  
296/181.1-181.5, 183.1  
CPC ..... B62D 25/00; B62D 25/06; B62D 33/00;  
B62D 35/00

See application file for complete search history.

(56) **References Cited**

**U.S. PATENT DOCUMENTS**

D620,396 S	7/2010	Reichman et al.
D626,466 S	11/2010	Reichman et al.
D629,718 S	12/2010	Reichman et al.
D629,719 S	12/2010	Reichman et al.
D629,725 S	12/2010	Reichman et al.
D630,140 S	1/2011	Reichman et al.
D670,640 S	11/2012	Reichman et al.
D687,348 S	8/2013	Nurnberger
D689,812 S	9/2013	Reichman et al.

D692,800 S	11/2013	Wiltshire	
D704,102 S	5/2014	Nurnberger	
D704,601 S	5/2014	Nurnberger	
D710,257 S *	8/2014	Giovannini	D12/92
D726,079 S	4/2015	Reichman et al.	
D727,212 S *	4/2015	Menegon	D12/92
D727,804 S	4/2015	Nurnberger	
D730,777 S	6/2015	Nurnberger	
D739,789 S	9/2015	Payne	
D740,725 S	10/2015	Payne	
D741,753 S *	10/2015	Perini	D12/92
D745,439 S *	12/2015	Manzoni	D12/92
D753,548 S *	4/2016	Gilles	D12/88
D753,549 S *	4/2016	Manzoni	D12/88

(Continued)

**OTHER PUBLICATIONS**

U.S. Appl. No. 29/616,008, filed Sep. 1, 2017.

(Continued)

*Primary Examiner* — Melody N Brown

(74) *Attorney, Agent, or Firm* — Dorsey & Whitney LLP

(57) **CLAIM**

The ornamental design for an automobile and/or replica thereof, as shown and described.

**DESCRIPTION**

FIG. 1 is a left, rear perspective view of an automobile and/or replica thereof showing our new design; FIG. 2 is a right side elevation view thereof. FIG. 3 is a front elevation view thereof. FIG. 4 is a rear elevation view thereof. FIG. 5 is a left side elevation view thereof. FIG. 6 is a top plan view thereof; and, FIG. 7 is a left, front perspective view thereof. The portions of the automobile shown in broken lines are for environmental and illustrative purpose and form no part of the claimed design.

**1 Claim, 6 Drawing Sheets**

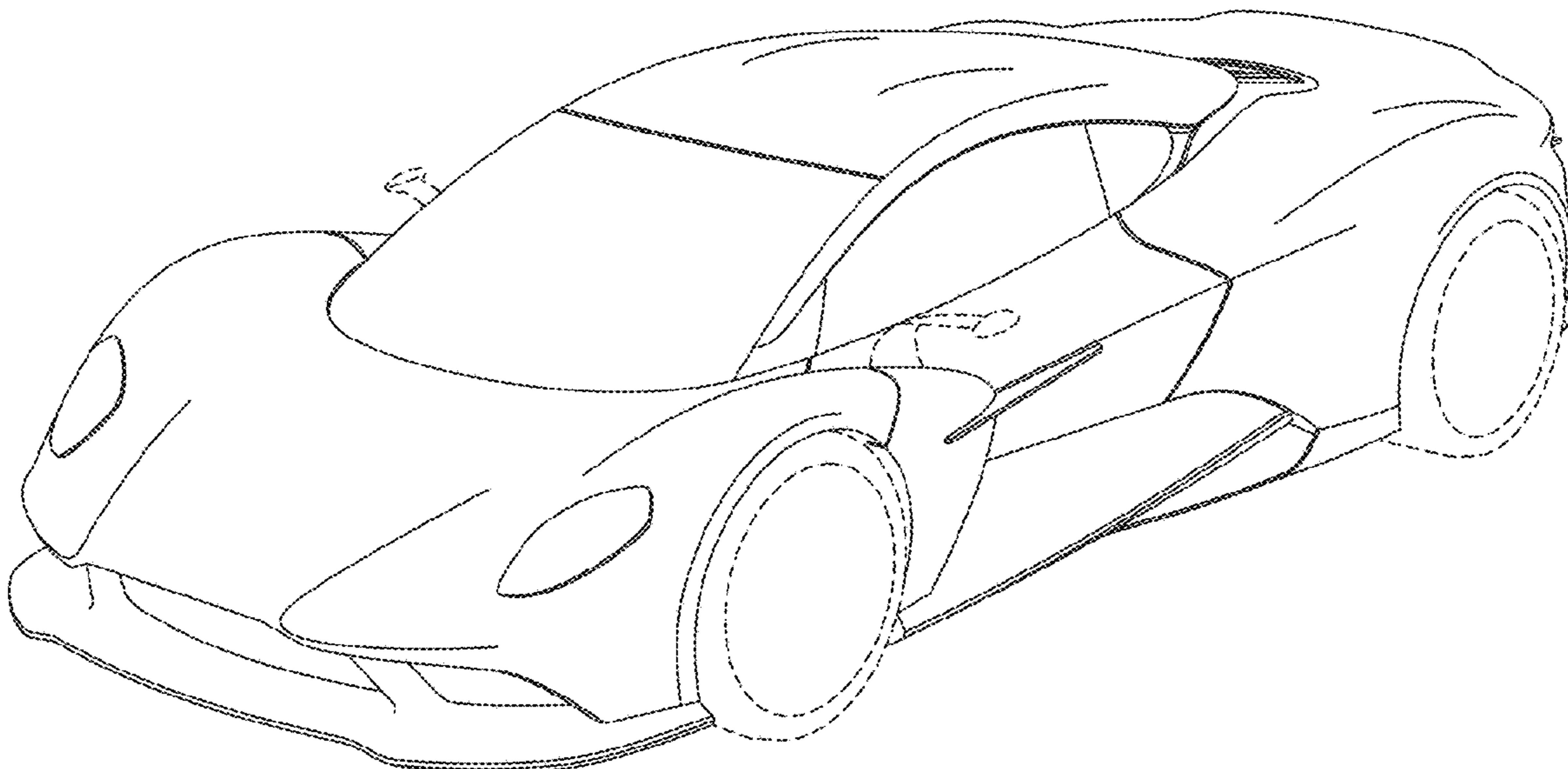

(56)

References Cited

U.S. PATENT DOCUMENTS

D755,674 S \* 5/2016 Perini ..... D12/88  
 D758,247 S 6/2016 Nurnberger et al.  
 D766,474 S 9/2016 Holgate et al.  
 D767,446 S \* 9/2016 Stephenson ..... D12/88  
 D768,035 S \* 10/2016 Goto ..... D12/88  
 D772,128 S 11/2016 Platt  
 D774,415 S \* 12/2016 Menegon ..... D12/88  
 D774,950 S 12/2016 Holgate et al.  
 D774,995 S 12/2016 Holgate et al.  
 D777,070 S 1/2017 Nurnberger  
 D778,790 S 2/2017 Nurnberger  
 D780,632 S 3/2017 Nurnberger  
 D780,633 S 3/2017 Nurnburger et al.  
 D780,634 S 3/2017 Nurnburger et al.  
 D780,636 S 3/2017 Kahn  
 D781,747 S \* 3/2017 Stephenson ..... D12/88  
 D781,748 S \* 3/2017 Manzoni ..... D12/88  
 D781,749 S \* 3/2017 Perini ..... D12/88  
 D785,525 S 5/2017 Nurnburger  
 D786,155 S 5/2017 Holgate et al.  
 D786,744 S 5/2017 Nurnberger et al.  
 D788,642 S \* 6/2017 Manzoni ..... D12/88  
 D796,404 S 9/2017 Nurnberger  
 D800,619 S 10/2017 Platt  
 D801,227 S \* 10/2017 Stephenson ..... D12/88  
 D801,558 S 10/2017 Nurnburger et al.  
 D815,995 S 4/2018 Nurnberger et al.  
 D817,814 S 5/2018 Nurnberger et al.  
 D820,164 S 6/2018 Nurnberger et al.  
 D825,387 S 8/2018 Nurnberger et al.  
 D826,092 S \* 8/2018 Manzoni ..... D12/92  
 D826,106 S 8/2018 Kahn  
 D827,166 S 8/2018 Nurnberger et al.  
 D827,410 S 9/2018 Earley  
 D827,411 S 9/2018 Earley  
 D827,507 S 9/2018 Nurnberger et al.  
 D830,917 S 10/2018 Nurnberger et al.

D833,187 S 11/2018 Earley  
 D835,548 S 12/2018 Nurnberger et al.  
 D838,017 S 1/2019 Nurnberger et al.  
 D838,018 S 1/2019 Nurnberger et al.  
 D840,873 S 2/2019 Nurnberger et al.  
 D841,847 S 2/2019 Re et al.  
 D842,799 S 3/2019 Nurnberger et al.  
 D848,331 S 5/2019 Nurnberger et al.  
 D849,616 S 5/2019 Nurnberger et al.  
 D855,528 S 8/2019 Re  
 D856,193 S 8/2019 Nurnberger et al.

OTHER PUBLICATIONS

U.S. Appl. No. 29/631,883, filed Jan. 3, 2018.  
 U.S. Appl. No. 29/631,887, filed Jan. 3, 2018.  
 U.S. Appl. No. 29/582,592, filed Oct. 28, 2016.  
 U.S. Appl. No. 29/616,006, filed Sep. 1, 2017.  
 U.S. Appl. No. 29/616,010, filed Sep. 1, 2017.  
 U.S. Appl. No. 29/626,411, filed Nov. 16, 2017.  
 U.S. Appl. No. 29/626,801, filed Nov. 20, 2017.  
 U.S. Appl. No. 29/647,96, filed May 17, 2018.  
 U.S. Appl. No. 29/658,851, filed Aug. 3, 2018.  
 U.S. Appl. No. 29/674,083, filed Dec. 19, 2018.  
 U.S. Appl. No. 29/682,466, filed Mar. 5, 2019.  
 U.S. Appl. No. 29/689,693, filed May 1, 2019.  
 U.S. Appl. No. 29/689,689, filed May 1, 2019.  
 U.S. Appl. No. 29/689,379, filed Apr. 29, 2019.  
 U.S. Appl. No. 29/698,779, filed Jul. 19, 2019.  
 U.S. Appl. No. 29/698,789, filed Jul. 19, 2019.  
 U.S. Appl. No. 29/699,560, filed Jul. 26, 2019.  
 Aston Martin 2013, "Aston Martin Centenary Celebration Programme," 2013; 204 pages.  
 1976 and 1987 Aston Martin Lagonda, [online], [site visited Jul. 24, 2014], Available from Internet, <URL: <http://www.astonmartin.com/heritage/past-models/lagonda>>, 2 pages.

\* cited by examiner

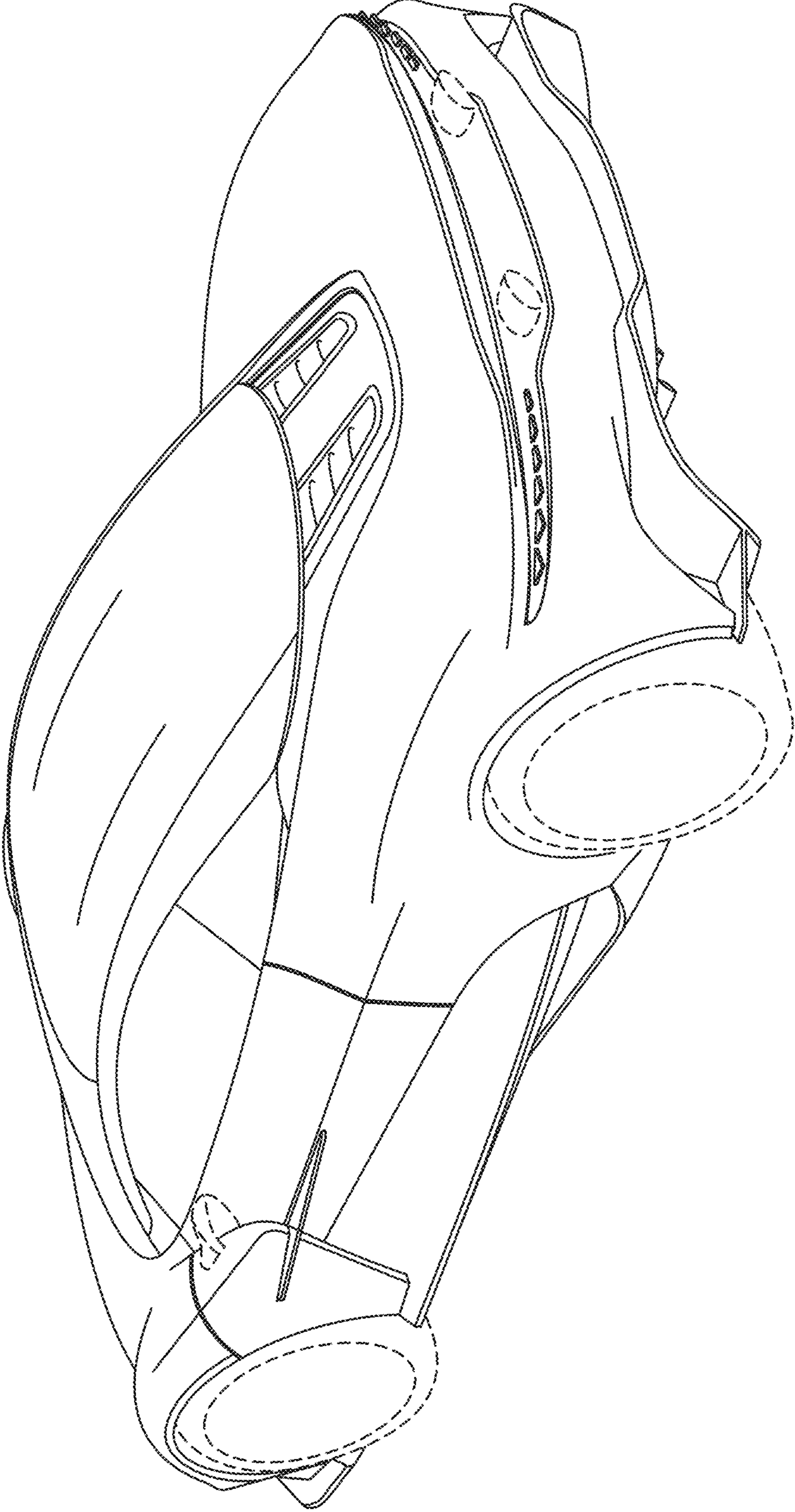

FIG. 1

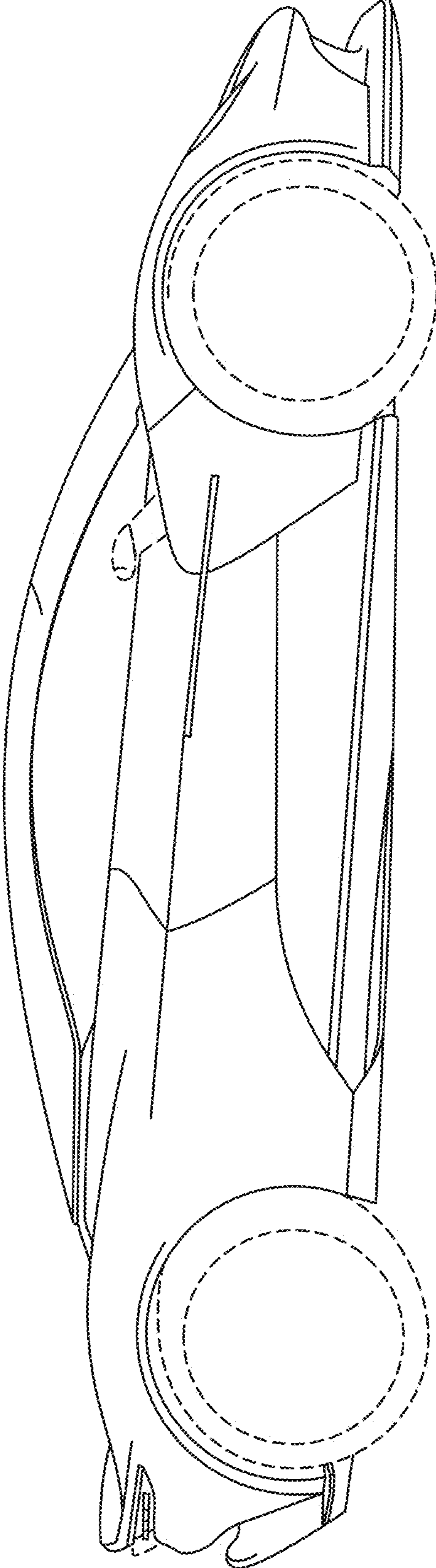

FIG. 2

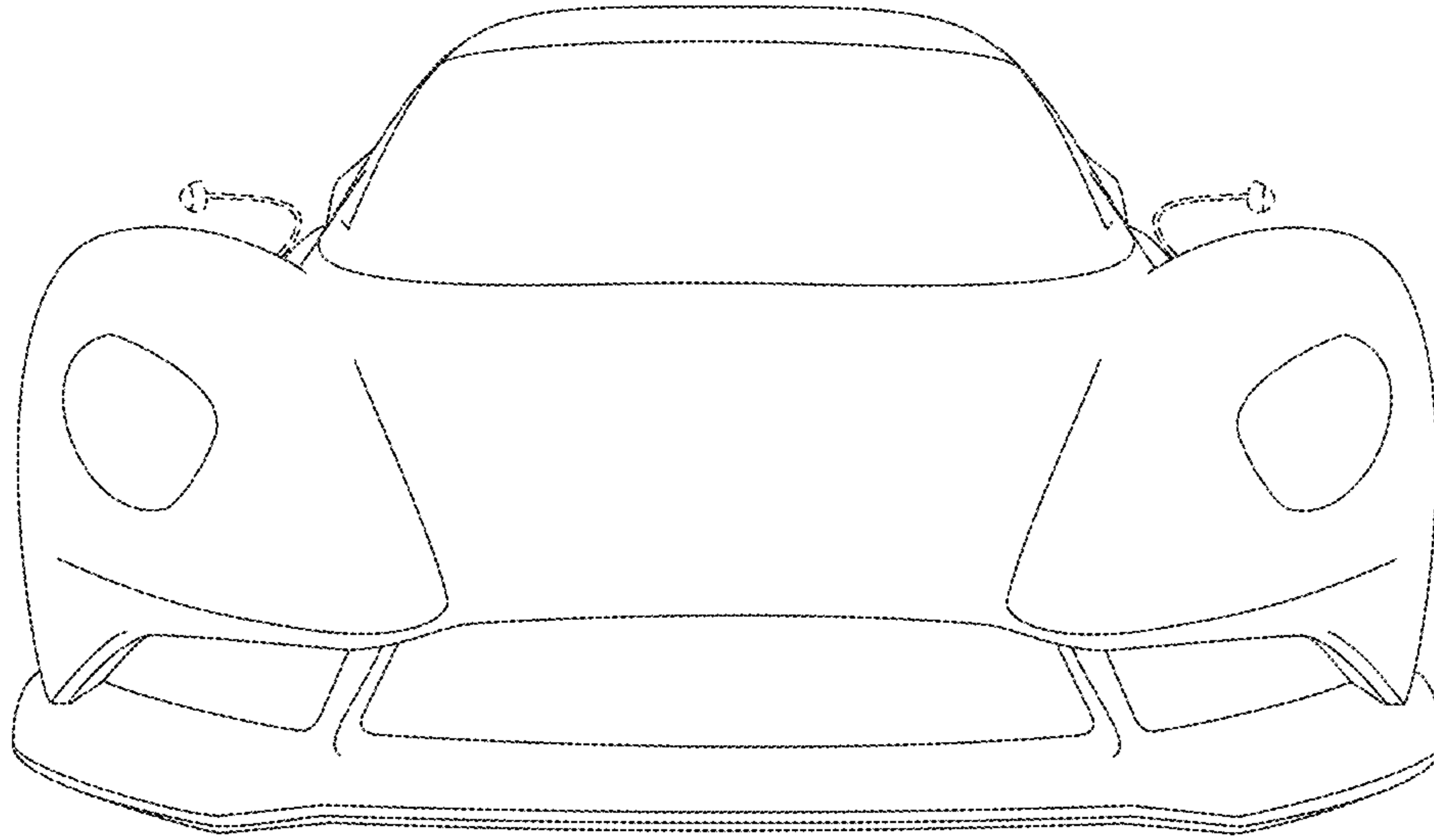

FIG. 3

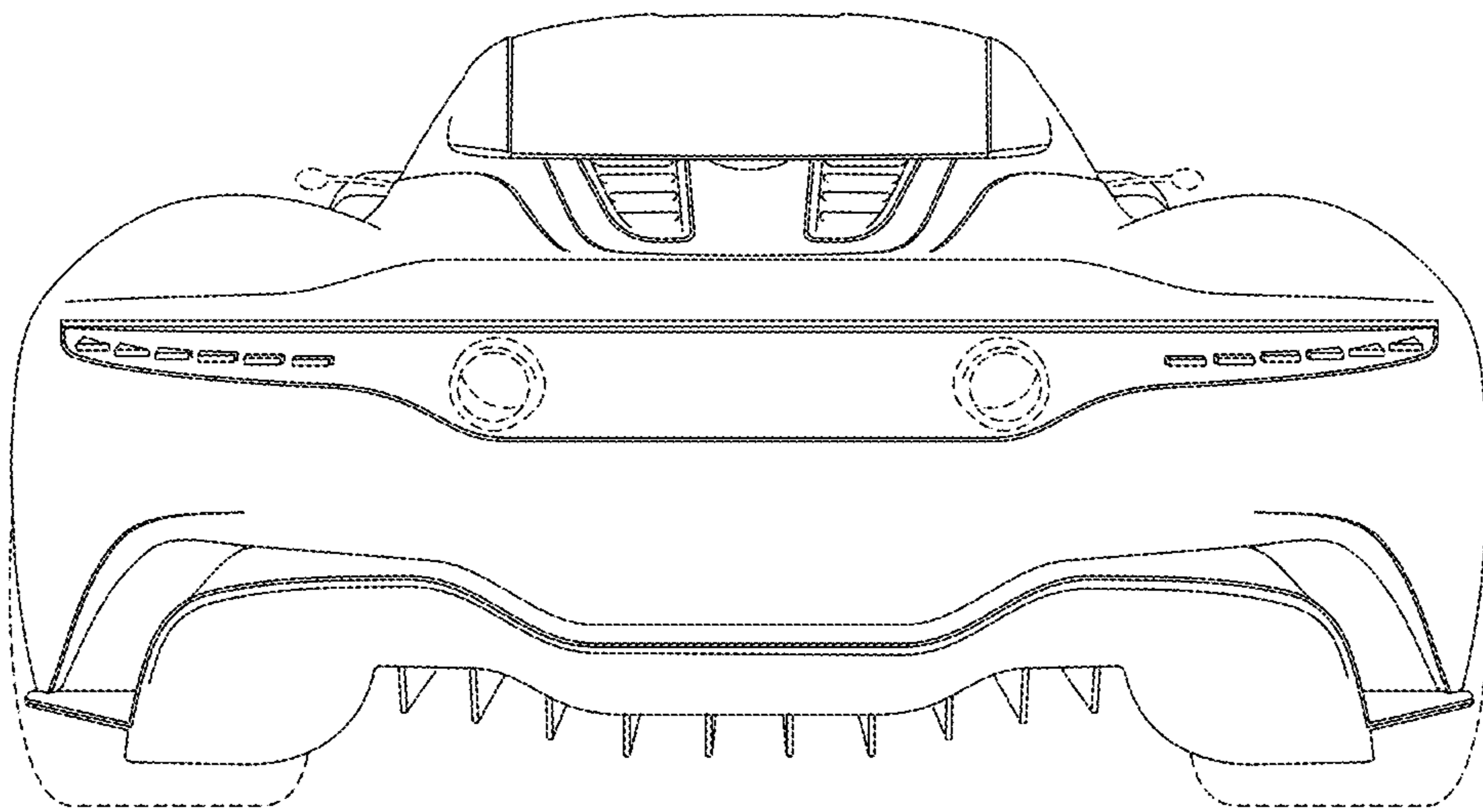

FIG. 4

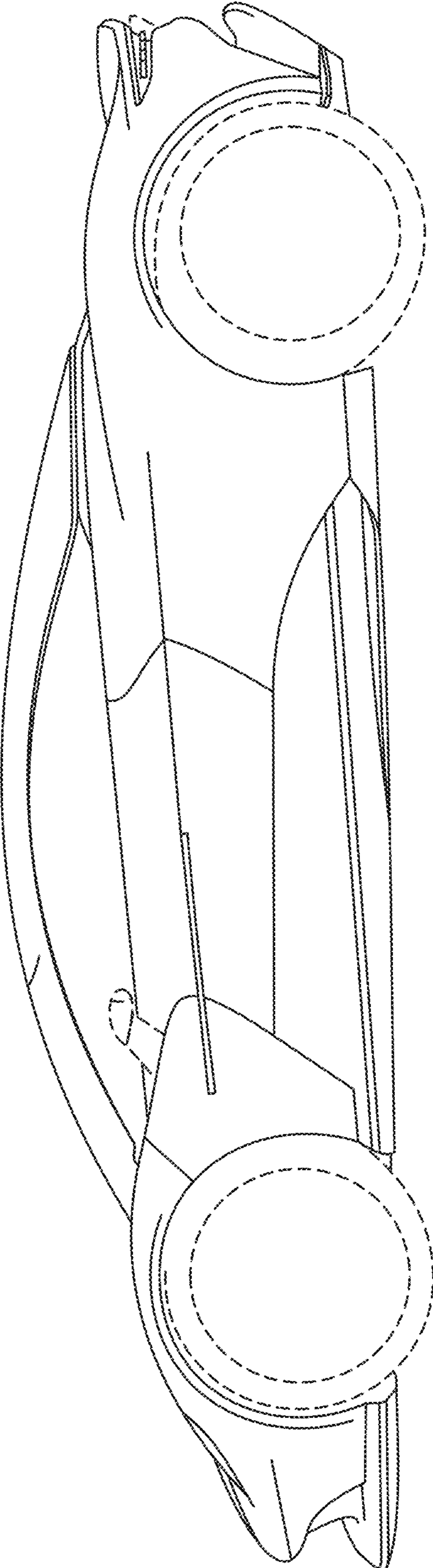

FIG. 5

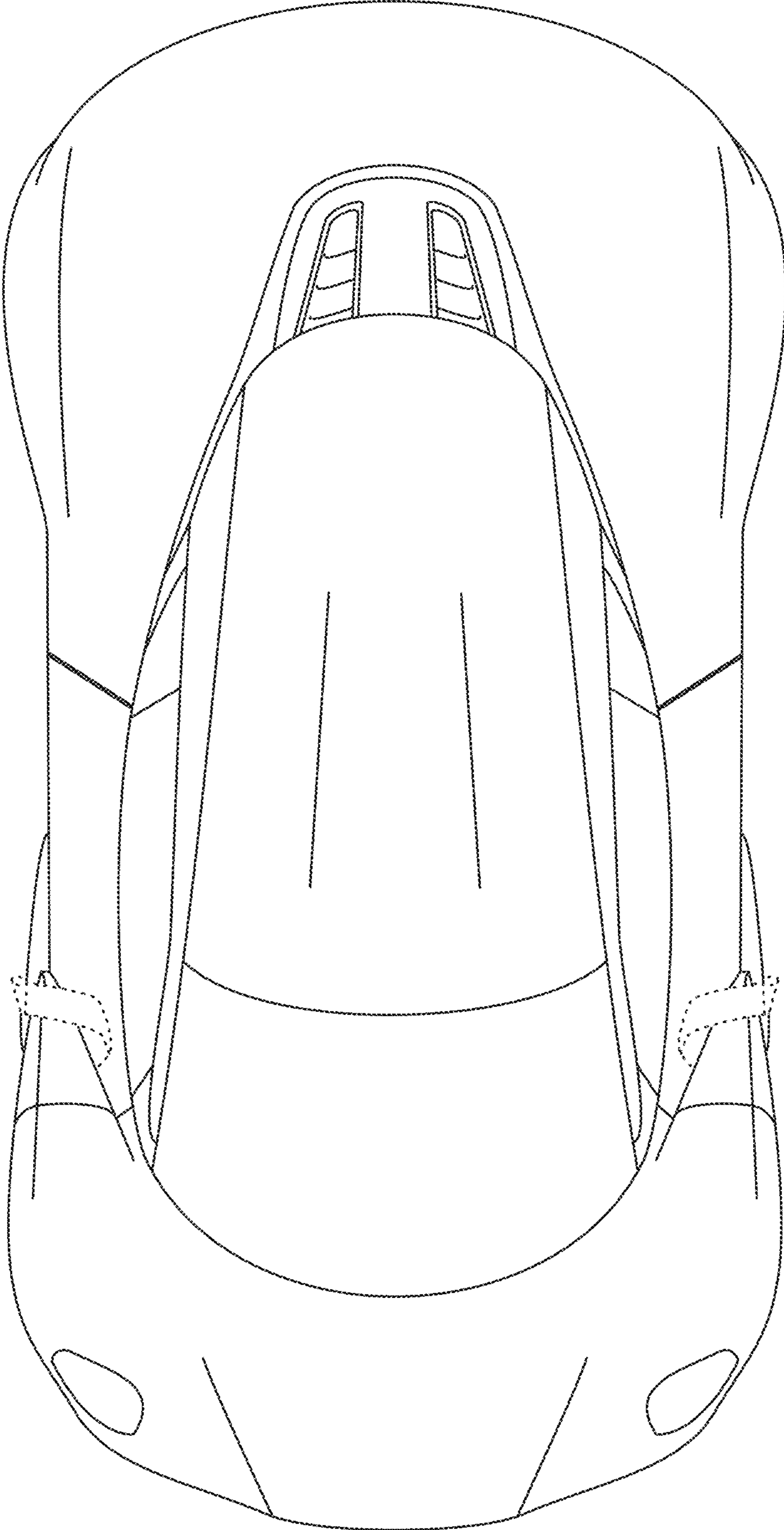

FIG. 6

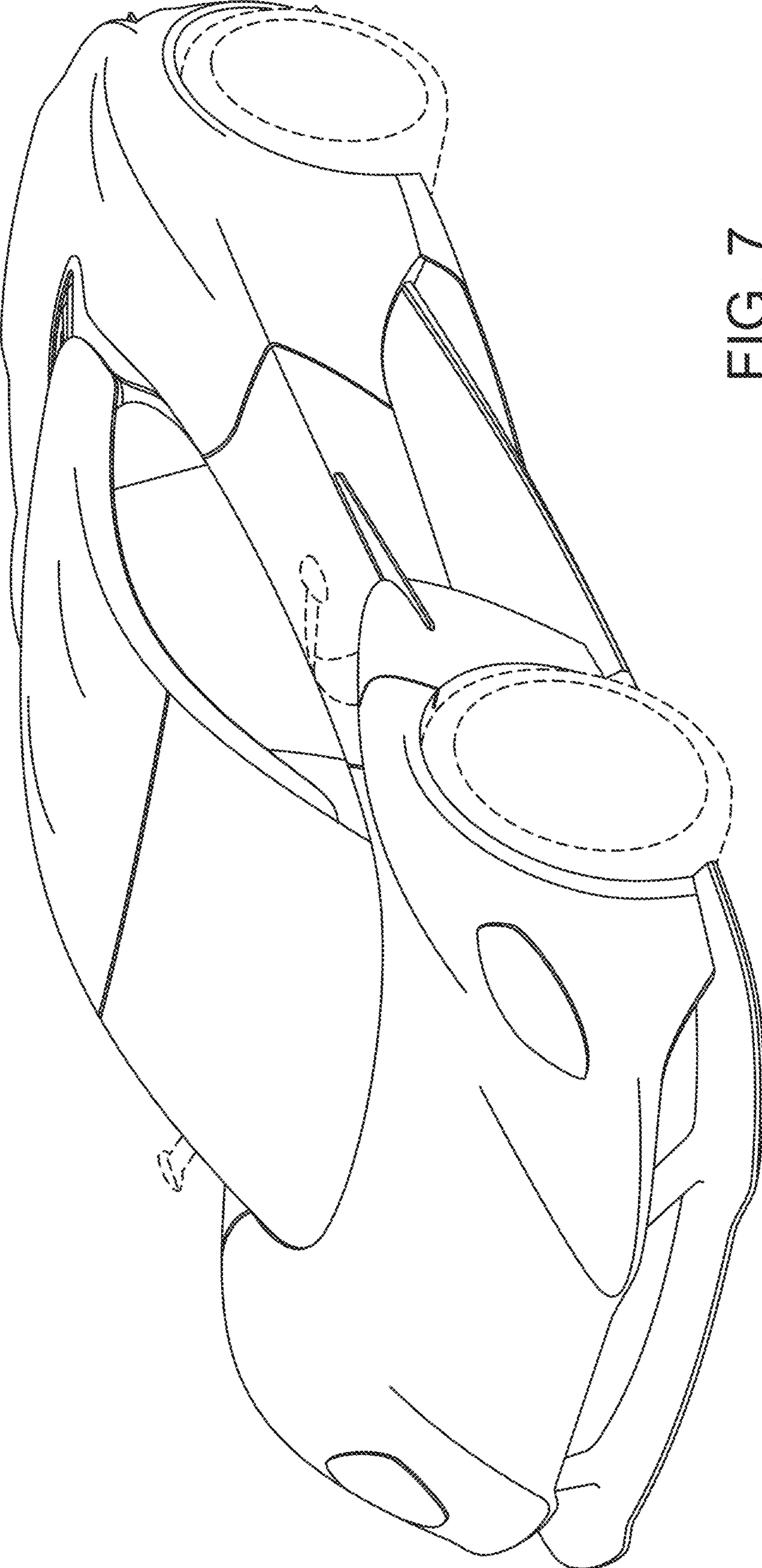

FIG. 7