



US00D913846S

(12) **United States Design Patent**
Tuft et al.

(10) **Patent No.:** **US D913,846 S**

(45) **Date of Patent:** **** Mar. 23, 2021**

- (54) **ELECTRIC UTILITY VEHICLE**
- (71) Applicant: **Nikola Corporation**, Phoenix, AZ (US)
- (72) Inventors: **Erik Tuft**, Phoenix, AZ (US); **Brendan Babiarz**, Mesa, AZ (US); **Lee Baroldy**, San Tan Valley, AZ (US); **Jordan Darling**, Mesa, AZ (US); **James R. Crawford**, Maricopa, AZ (US); **Nicolas Laberge**, Phoenix, AZ (US)
- (73) Assignee: **Nikola Corporation**, Phoenix, AZ (US)
- (**) Term: **15 Years**
- (21) Appl. No.: **29/687,746**
- (22) Filed: **Apr. 15, 2019**
- (51) **LOC (13) Cl.** **12-08**
- (52) **U.S. Cl.**
USPC **D12/87**
- (58) **Field of Classification Search**
USPC D12/3, 4, 5, 14, 85, 86, 87, 107, 110
CPC B62D 23/00; B62D 21/18; B62D 21/183;
B62D 24/02; B62D 25/00; B62D 39/00;
B62D 49/06; B62D 49/0621
See application file for complete search history.

D719,061	S *	12/2014	Tandrup	D12/87
D727,794	S *	4/2015	Tandrup	D12/87
9,016,760	B2 *	4/2015	Kuroda	B60R 21/06 296/146.9
D736,118	S *	8/2015	Hashimoto	D12/87
9,457,756	B2 *	10/2016	Hirooka	B60R 9/06
D819,492	S *	6/2018	Flores	D12/14
D868,629	S *	12/2019	Mikhailov	D12/87
D879,663	S *	3/2020	Barlow, Jr.	D12/87
10,625,639	B2 *	4/2020	Deschamps	B60N 2/36
D896,703	S *	9/2020	Dunshee	D12/87
10,766,533	B2 *	9/2020	Houkom	B60R 21/13
2009/0184531	A1 *	7/2009	Yamamura	B62D 33/02 296/37.6
2010/0314191	A1 *	12/2010	Deckard	B60R 21/13 180/312
2013/0087402	A1 *	4/2013	Kaku	B60K 11/06 180/309

* cited by examiner

Primary Examiner — Darlington Ly

(74) *Attorney, Agent, or Firm* — Snell & Wilmer L.L.P.

(57) **CLAIM**

The ornamental design for an electric utility vehicle, as shown and described.

DESCRIPTION

FIG. 1 is a top, front, and left side perspective view of an electric utility vehicle embodying our new design;
 FIG. 2 is a front elevation view thereof;
 FIG. 3 is a rear elevation view thereof;
 FIG. 4 is a left side elevation view thereof;
 FIG. 5 is a right side elevation view thereof;
 FIG. 6 is a top plan view thereof; and,
 FIG. 7 is a bottom plan view thereof.
 The broken lines in the drawings illustrate portions of the electric utility vehicle that form no part of the claimed design.

1 Claim, 7 Drawing Sheets

(56) **References Cited**

U.S. PATENT DOCUMENTS

D498,435	S *	11/2004	Saito	D12/1
D606,900	S *	12/2009	Flores	D12/87
D636,295	S *	4/2011	Eck	D12/1
D646,604	S *	10/2011	Zhang	D12/16
8,328,235	B2 *	12/2012	Schneider	B62D 23/005 280/748
D675,960	S *	2/2013	Hashimoto	D12/87
8,585,088	B1 *	11/2013	Kaku	B62D 21/183 280/756
D700,869	S *	3/2014	Sato	D12/14

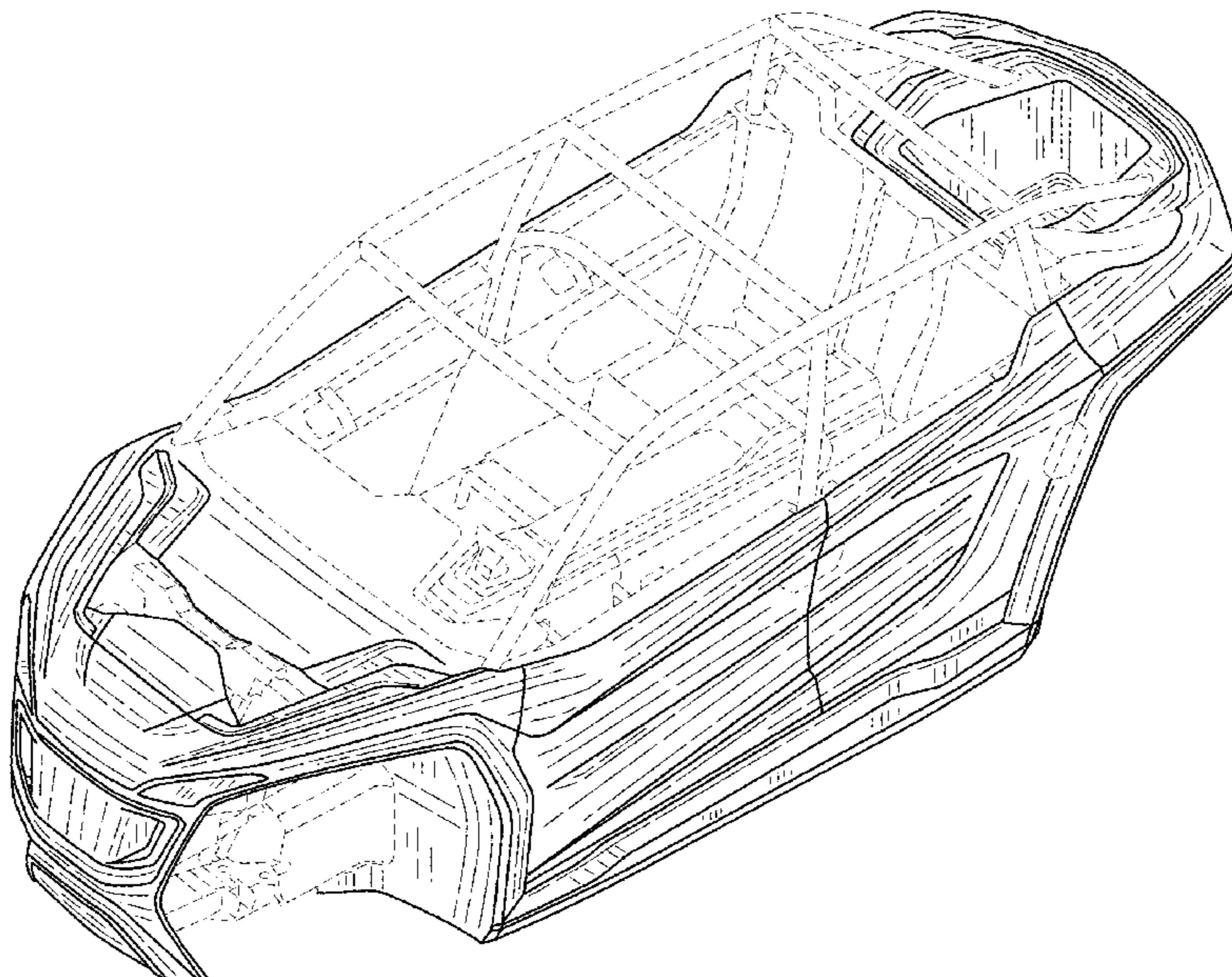

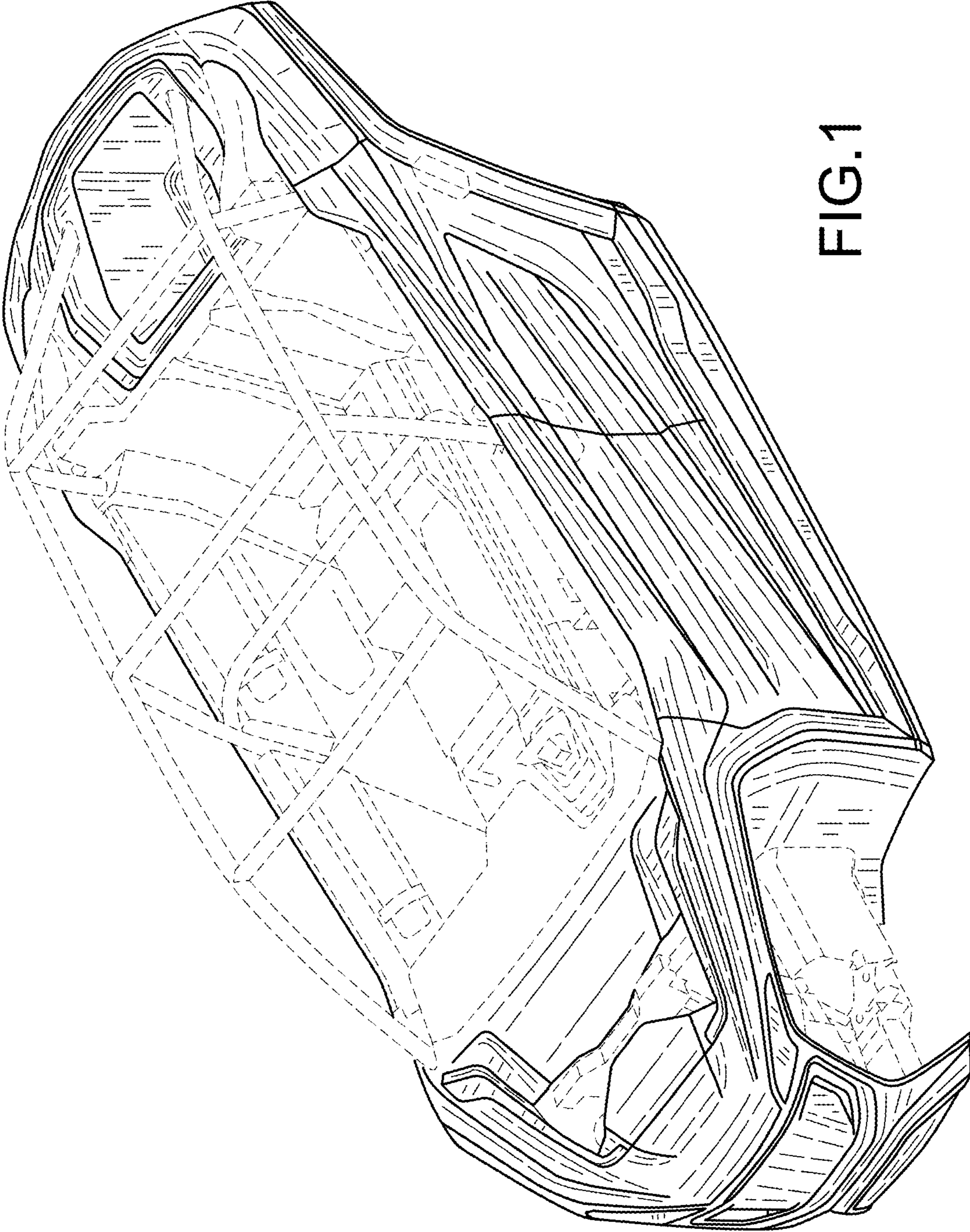

FIG.1

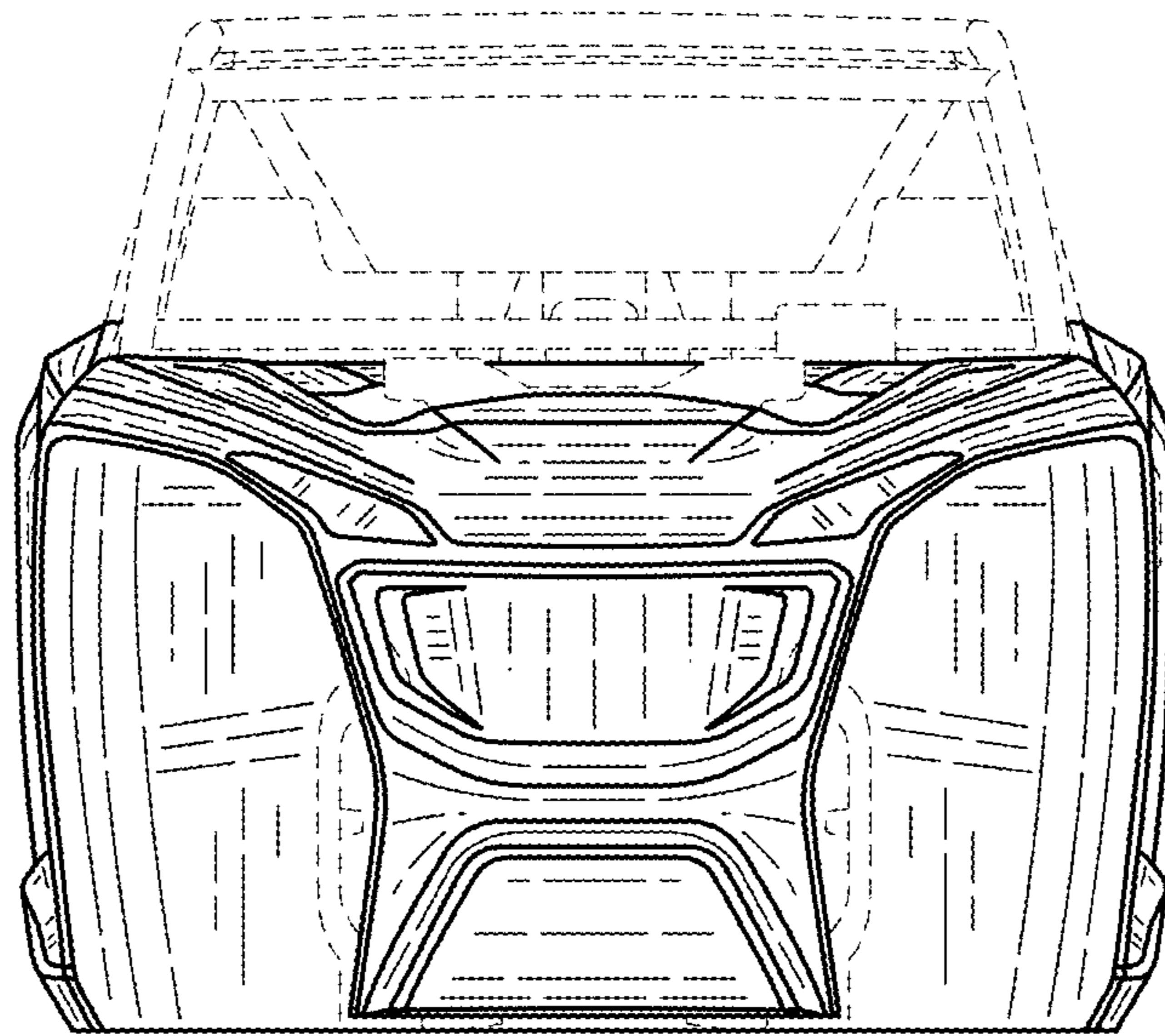

FIG.2

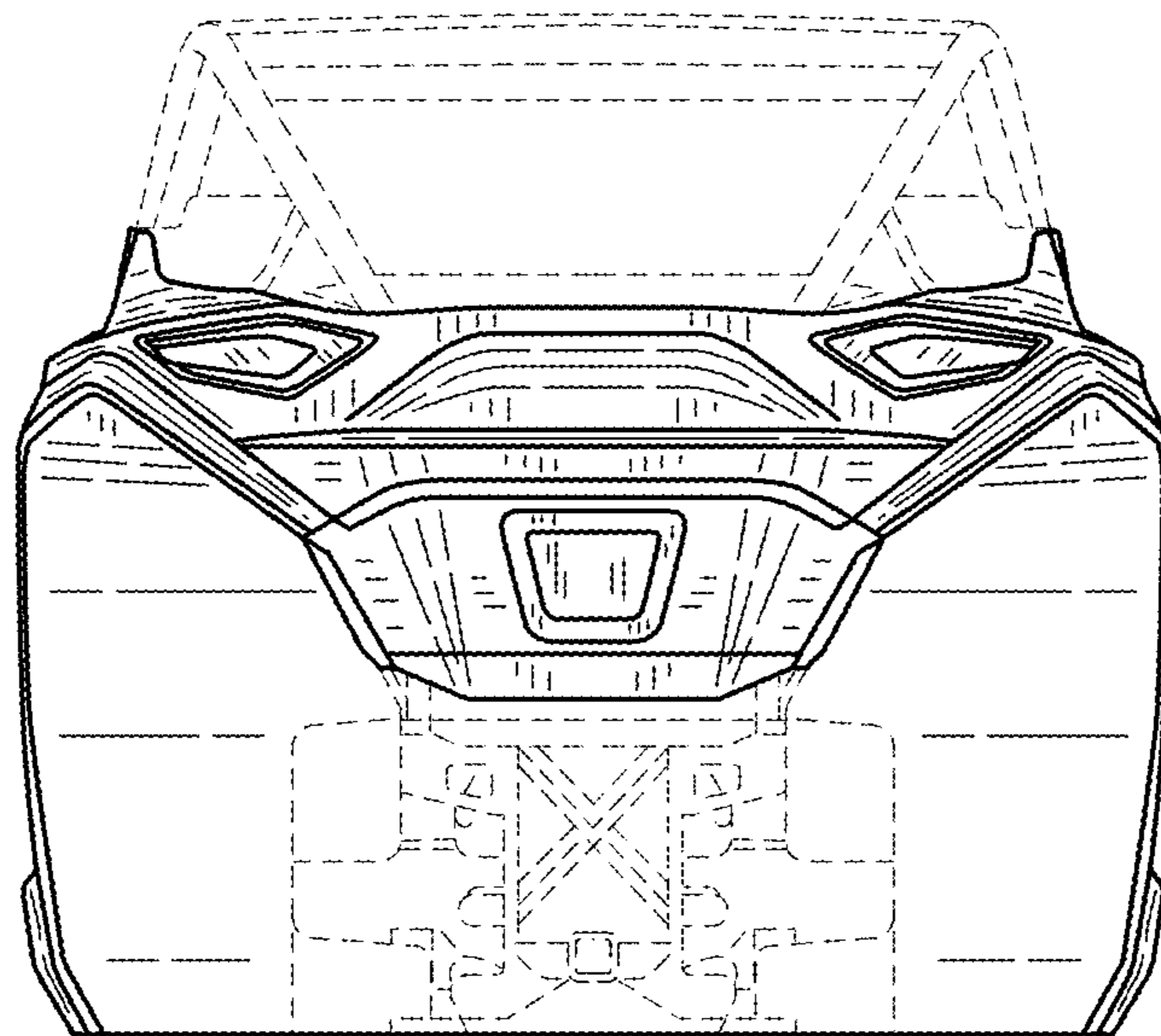

FIG.3

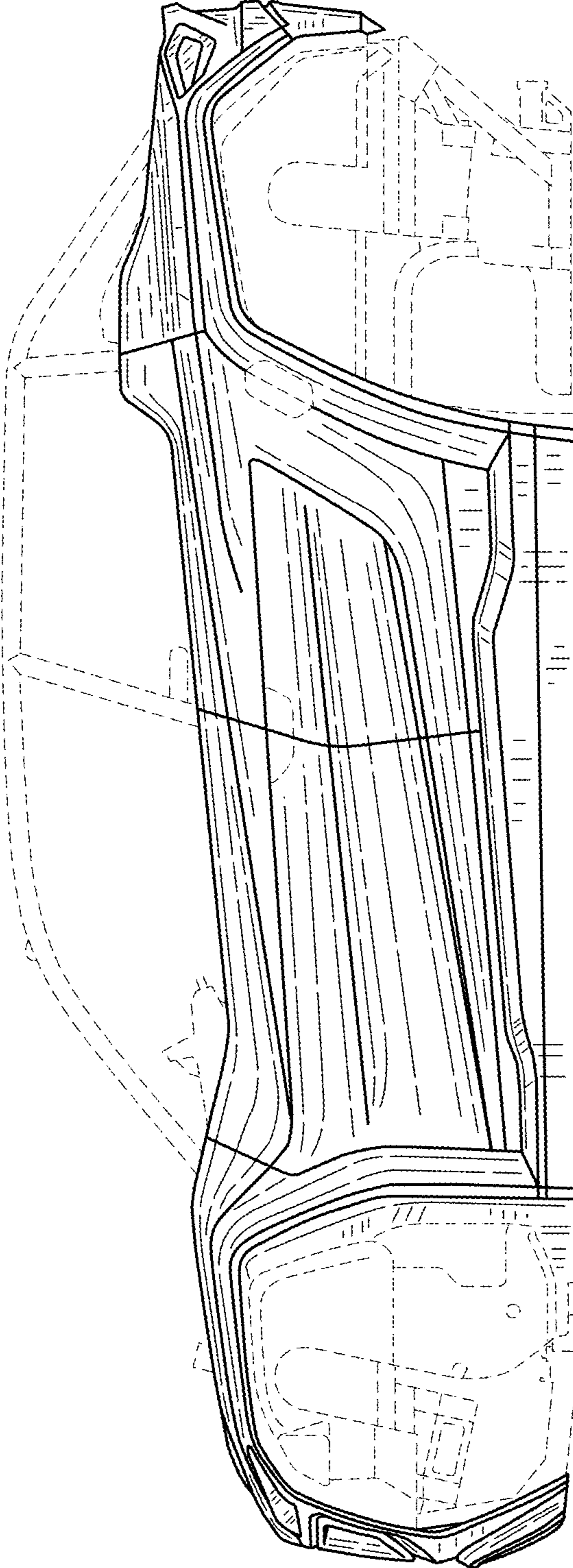

FIG.4

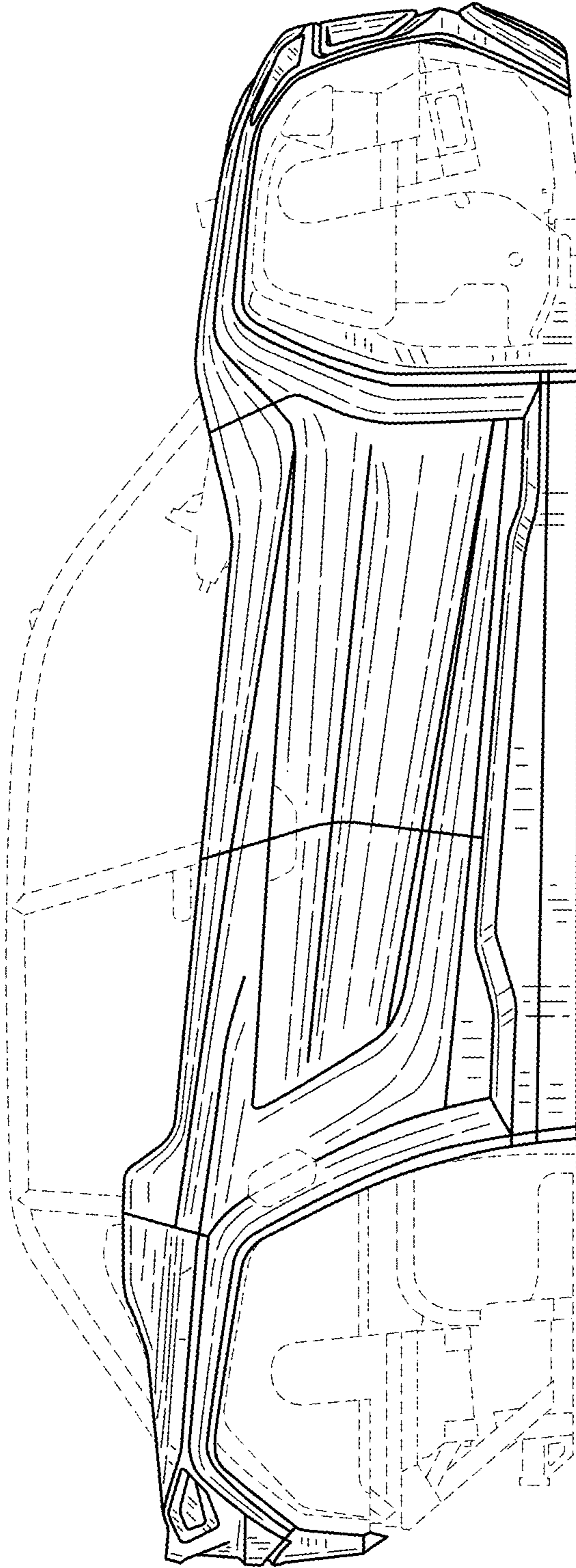

FIG. 5

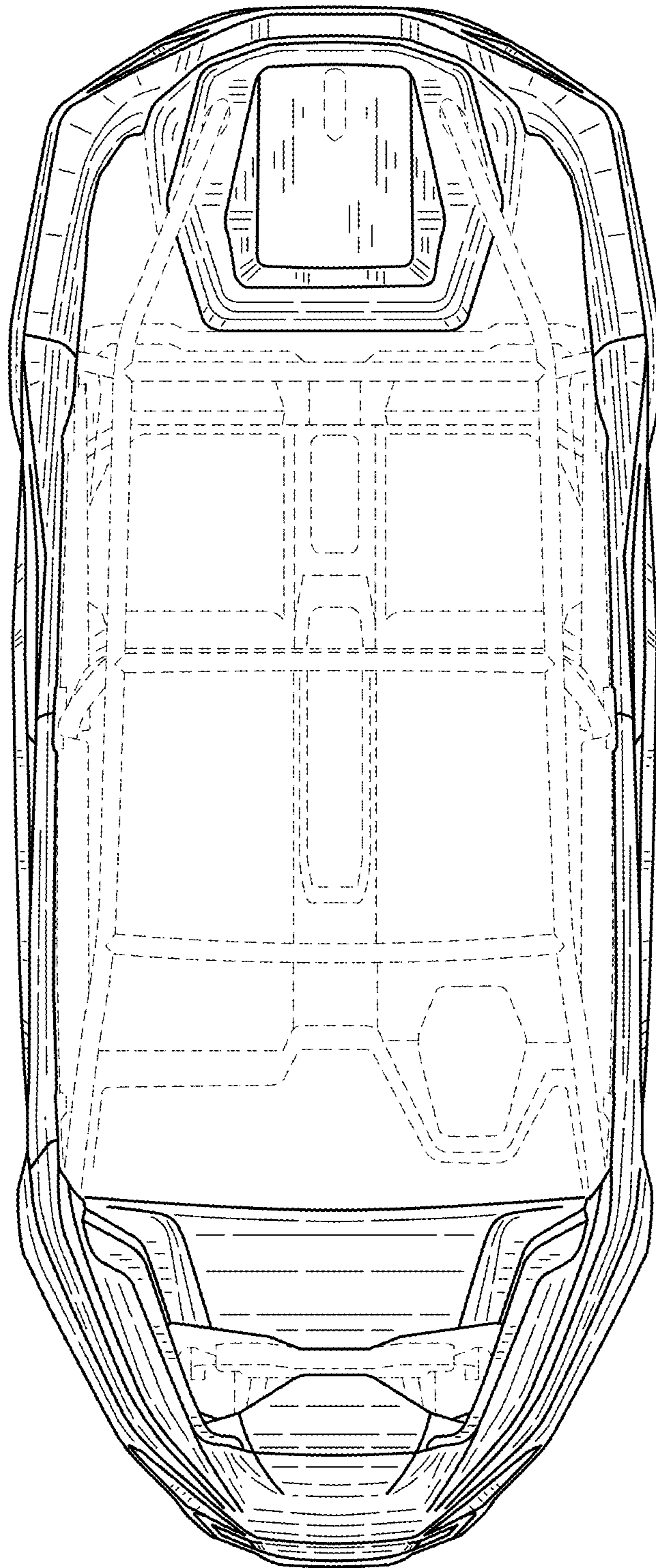

FIG.6

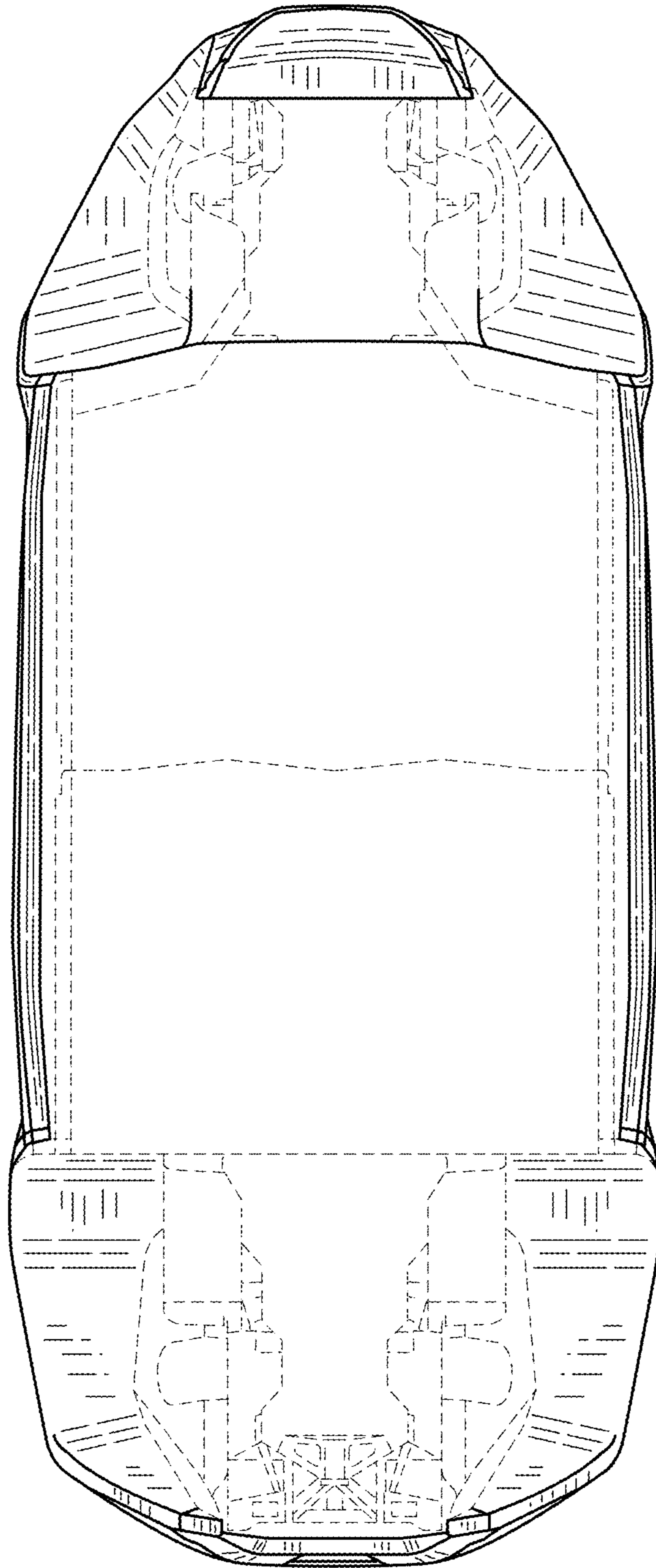

FIG. 7