



US00D913724S

(12) **United States Design Patent**  
**Cameron**

(10) **Patent No.:** **US D913,724 S**

(45) **Date of Patent:** **\*\* Mar. 23, 2021**

(54) **FOOT PILLOW**

8,327,483 B1 \* 12/2012 Zamora ..... A47G 9/10  
5/636

(71) Applicant: **Robert Malcolm Cameron**, Las Vegas,  
NV (US)

D721,519 S \* 1/2015 Gray, III ..... D6/601

D779,856 S \* 2/2017 Rich ..... D6/601

D845,674 S \* 4/2019 Hariri ..... D6/601

D896,546 S \* 9/2020 Lowder ..... D6/601

D898,423 S \* 10/2020 Liu ..... D6/601

(72) Inventor: **Robert Malcolm Cameron**, Las Vegas,  
NV (US)

\* cited by examiner

(\*\*) Term: **15 Years**

*Primary Examiner* — Jennifer L Rempfer

(21) Appl. No.: **29/698,236**

(74) *Attorney, Agent, or Firm* — Quickpatents, LLC;  
Kevin Prince

(22) Filed: **Jul. 15, 2019**

(51) **LOC (13) Cl.** ..... **06-09**

(57) **CLAIM**

(52) **U.S. Cl.**

The ornamental design for a foot pillow, as shown and  
described.

USPC ..... **D6/601**

(58) **Field of Classification Search**

**DESCRIPTION**

USPC ..... D6/582–583, 587–592, 595–609,

D6/617–622; D21/803–809; D24/183

CPC ..... A47G 9/00; A47G 2009/001; A47G

2009/002; A47G 2009/003; A47G 9/10;

A47G 9/1009; A47G 2009/1018; A47G

9/1045; A47G 9/1081; A47G 9/109

See application file for complete search history.

FIG. 1 is a front perspective view of a foot pillow, showing  
my new design in a used configuration by a person;

FIG. 2 is a rear perspective view thereof in a natural  
configuration;

FIG. 3 is a right-side elevational view of FIG. 2;

FIG. 4 is a left-side elevational view of FIG. 2;

FIG. 5 is a front elevational view of FIG. 2;

FIG. 6 is a rear elevational view of FIG. 2; and,

FIG. 7 is a top plan view of FIG. 2, the bottom plan view  
being a mirror image thereof.

The broken lines showing a person in FIG. 1 depict envi-  
ronmental matter and form no part of the claimed design.

The remaining broken lines represent portions of the foot  
pillow that form no part of the claimed design.

(56) **References Cited**

**U.S. PATENT DOCUMENTS**

1,447,288 A \* 3/1923 Emmerich ..... A47G 9/10

5/645

D282,036 S \* 1/1986 Ritchie, Jr. .... D6/595

6,601,252 B1 \* 8/2003 Leach ..... A47C 1/146

5/420

D487,207 S \* 3/2004 Manuel ..... D6/601

8,245,339 B2 \* 8/2012 Murray ..... A47G 9/10

5/657

**1 Claim, 4 Drawing Sheets**

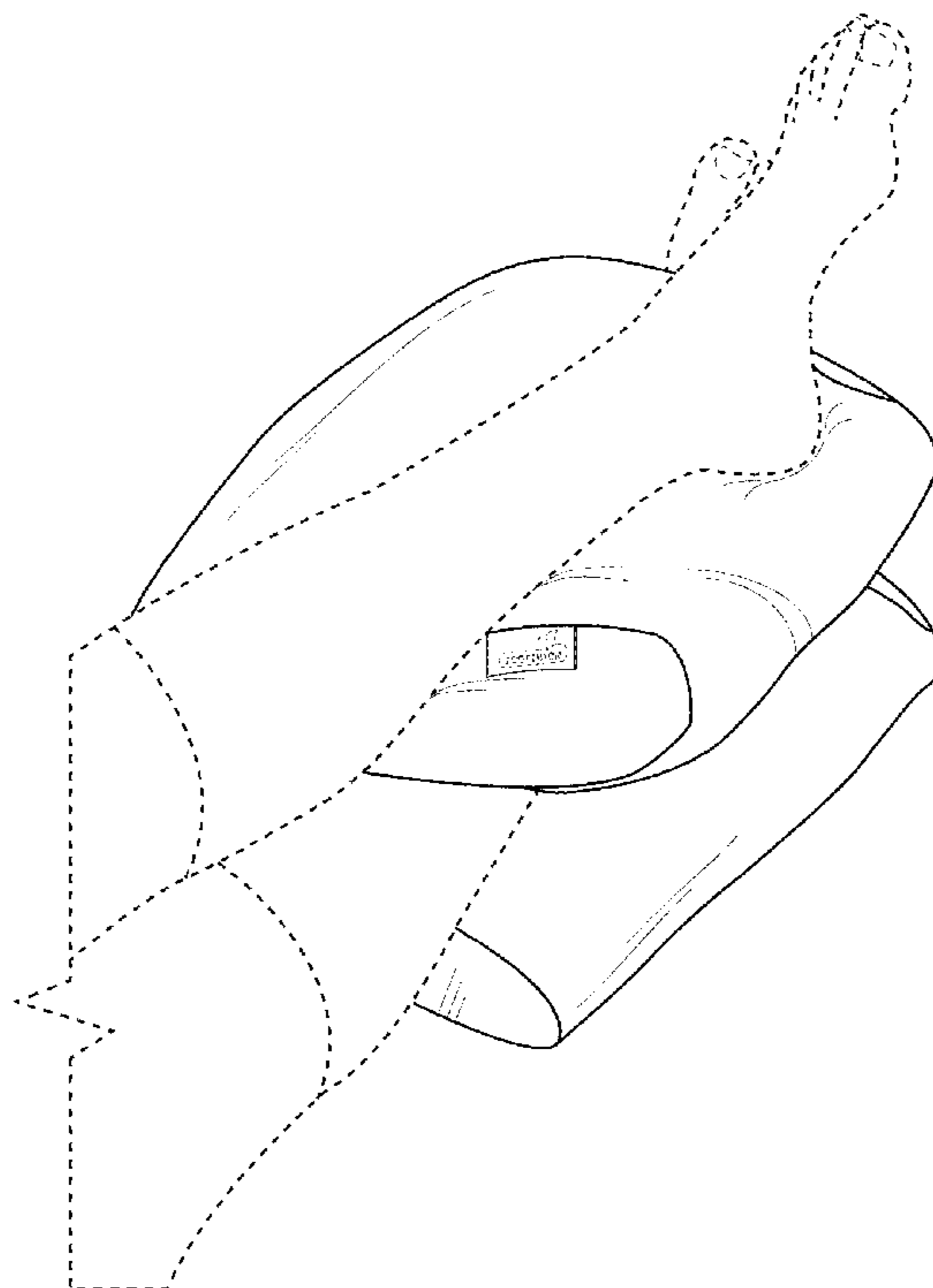

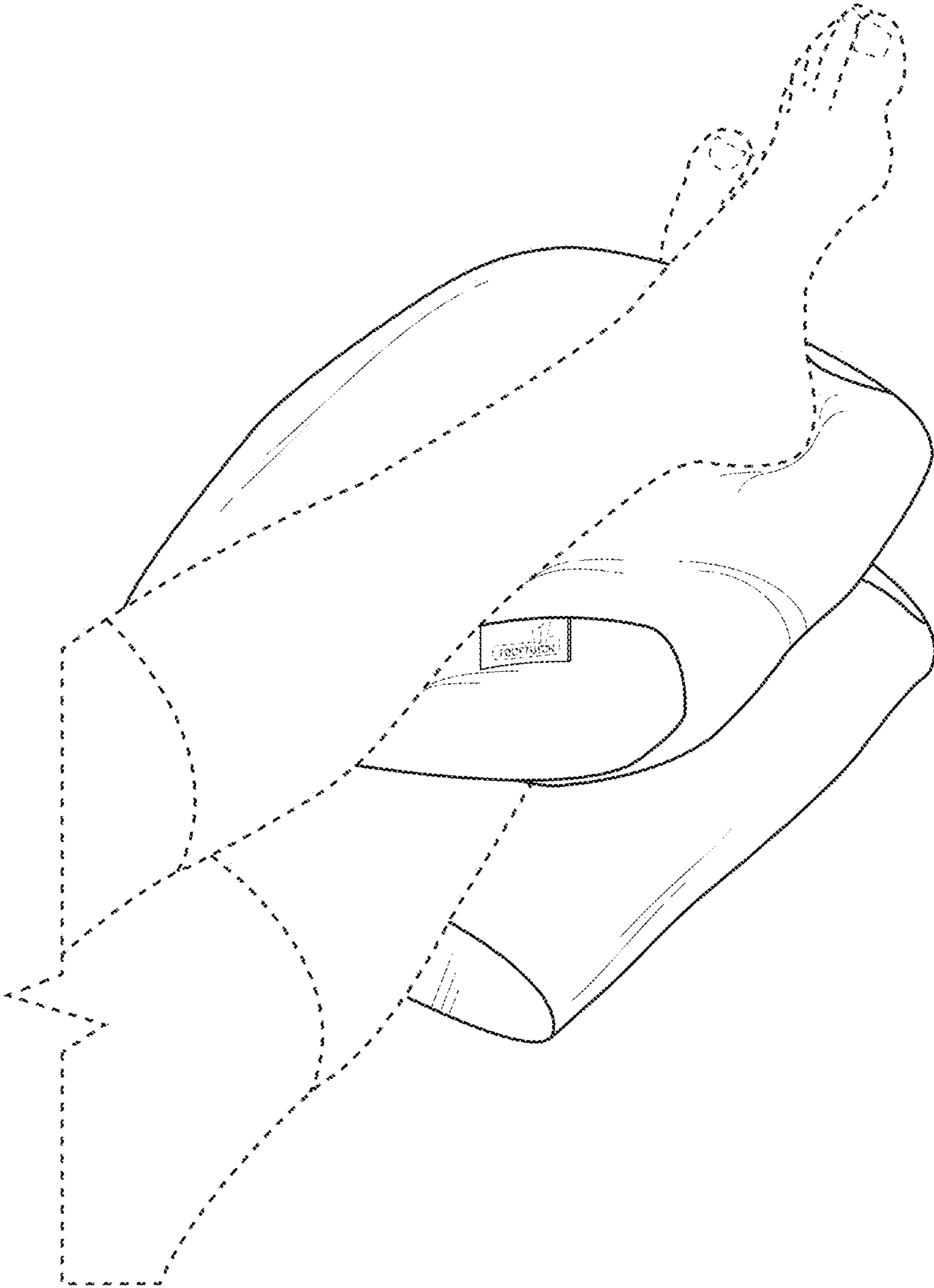

FIG. 1

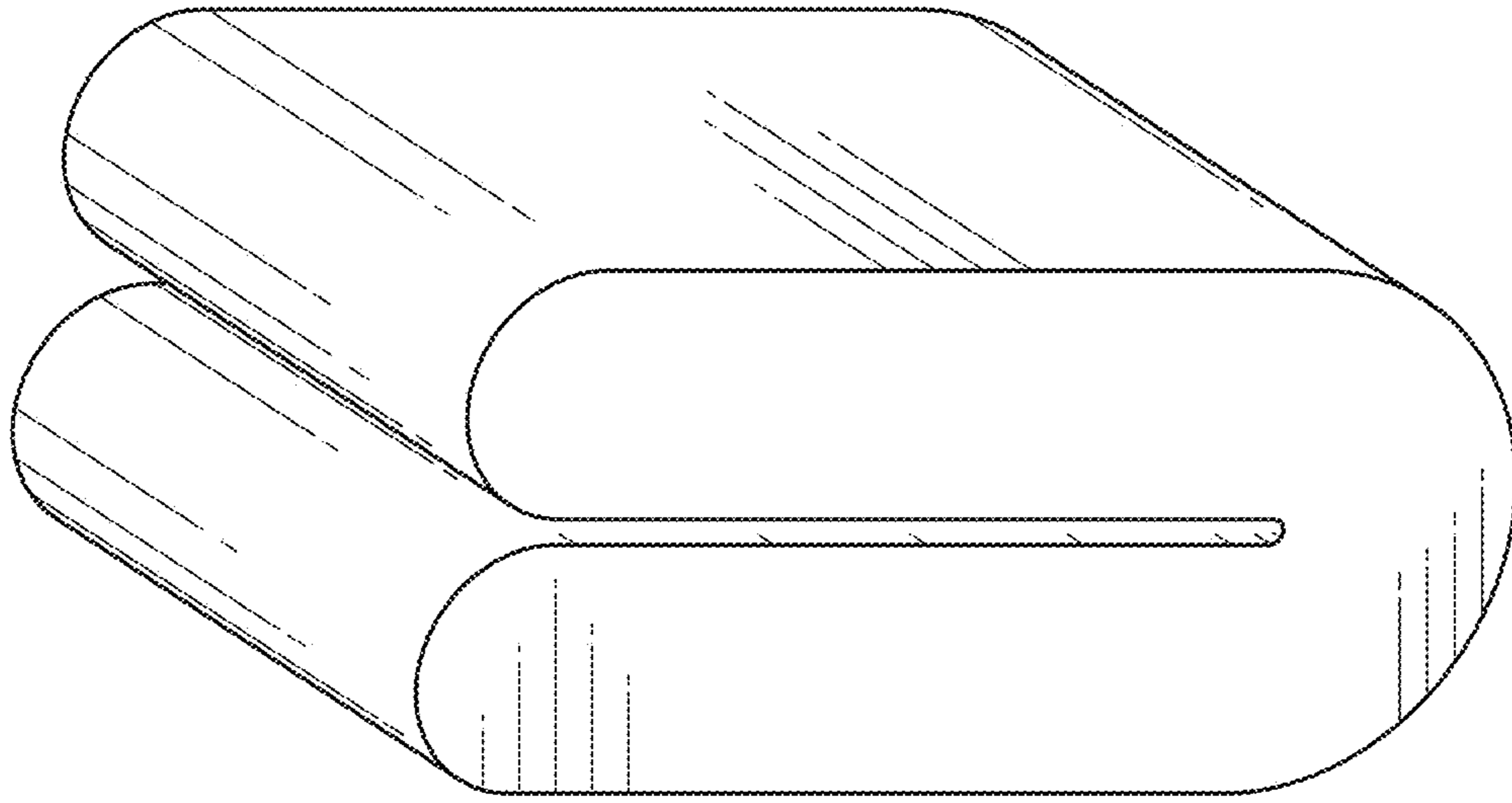

FIG. 2

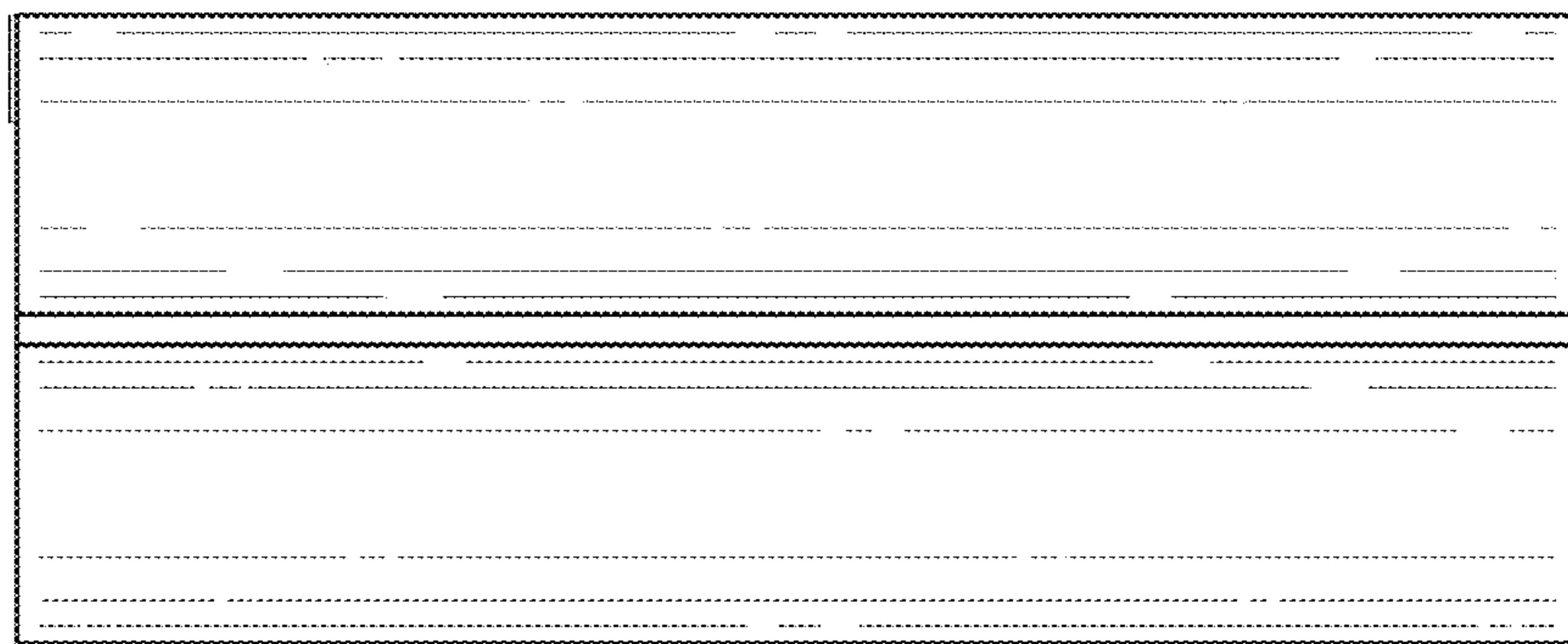

FIG. 3

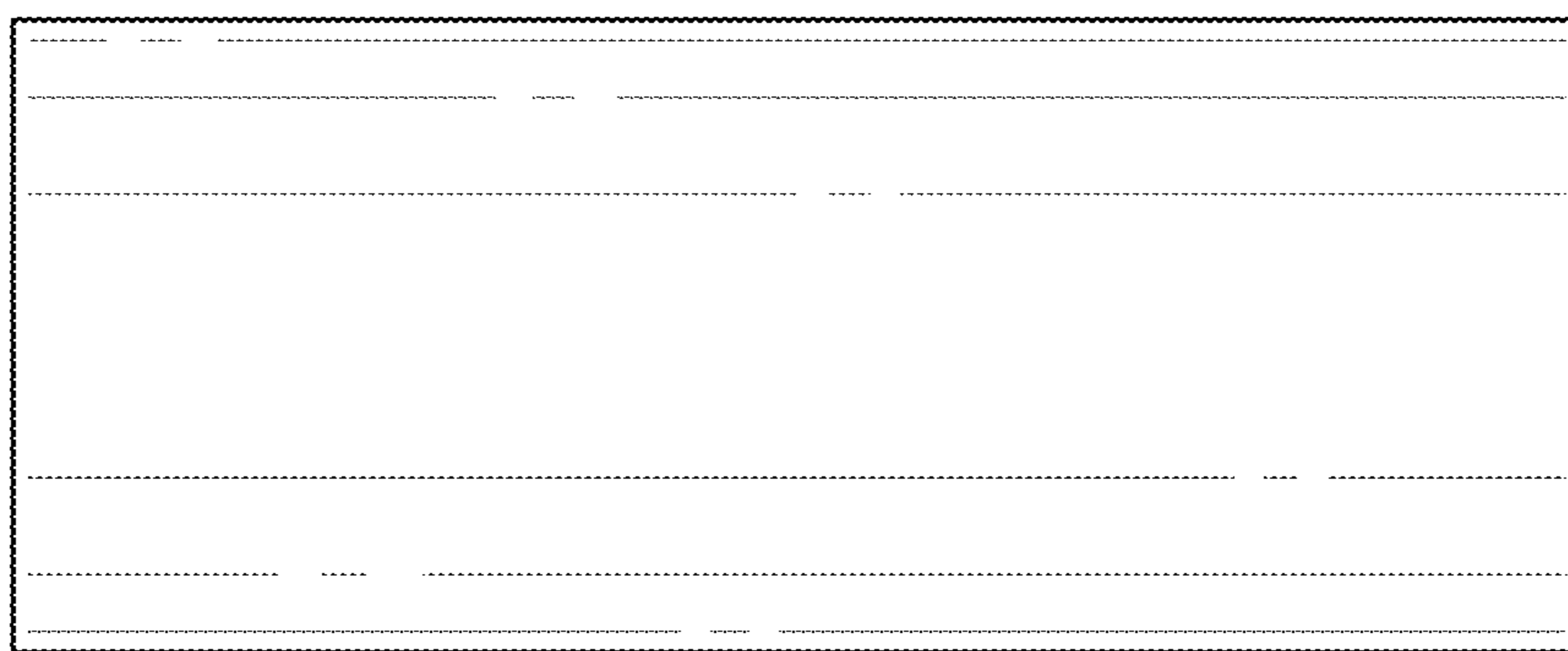

FIG. 4

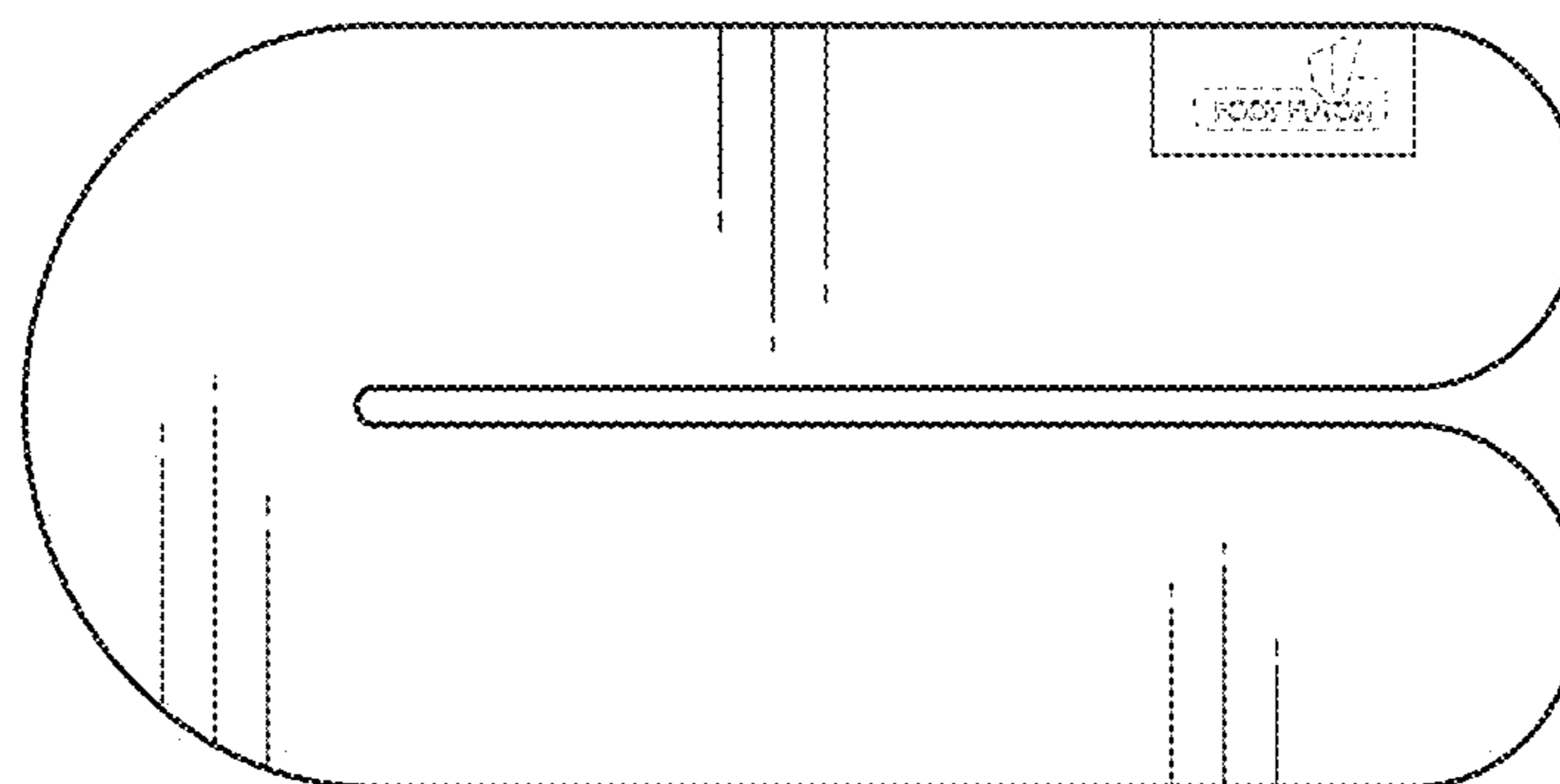

FIG 5

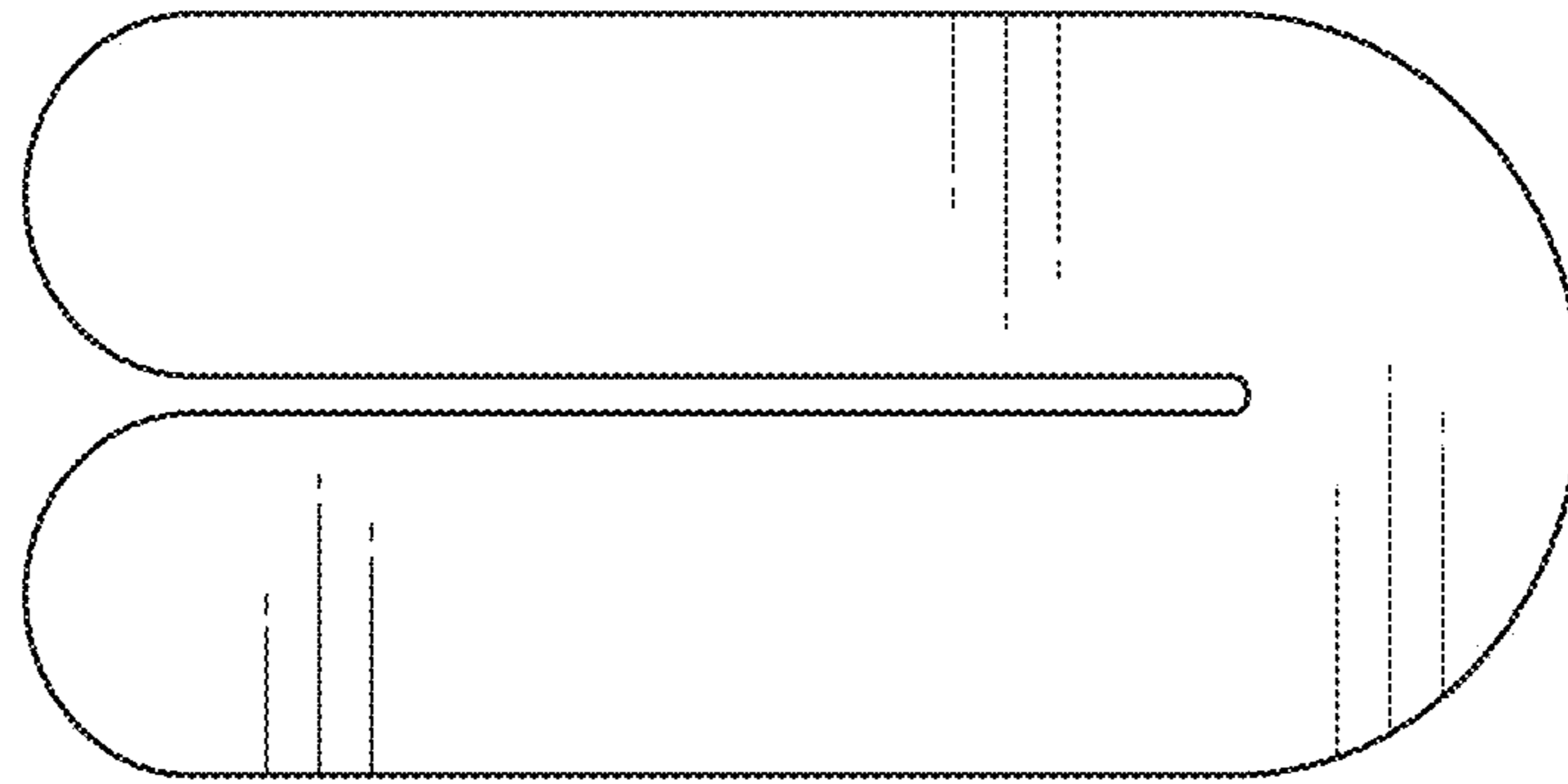

FIG. 6

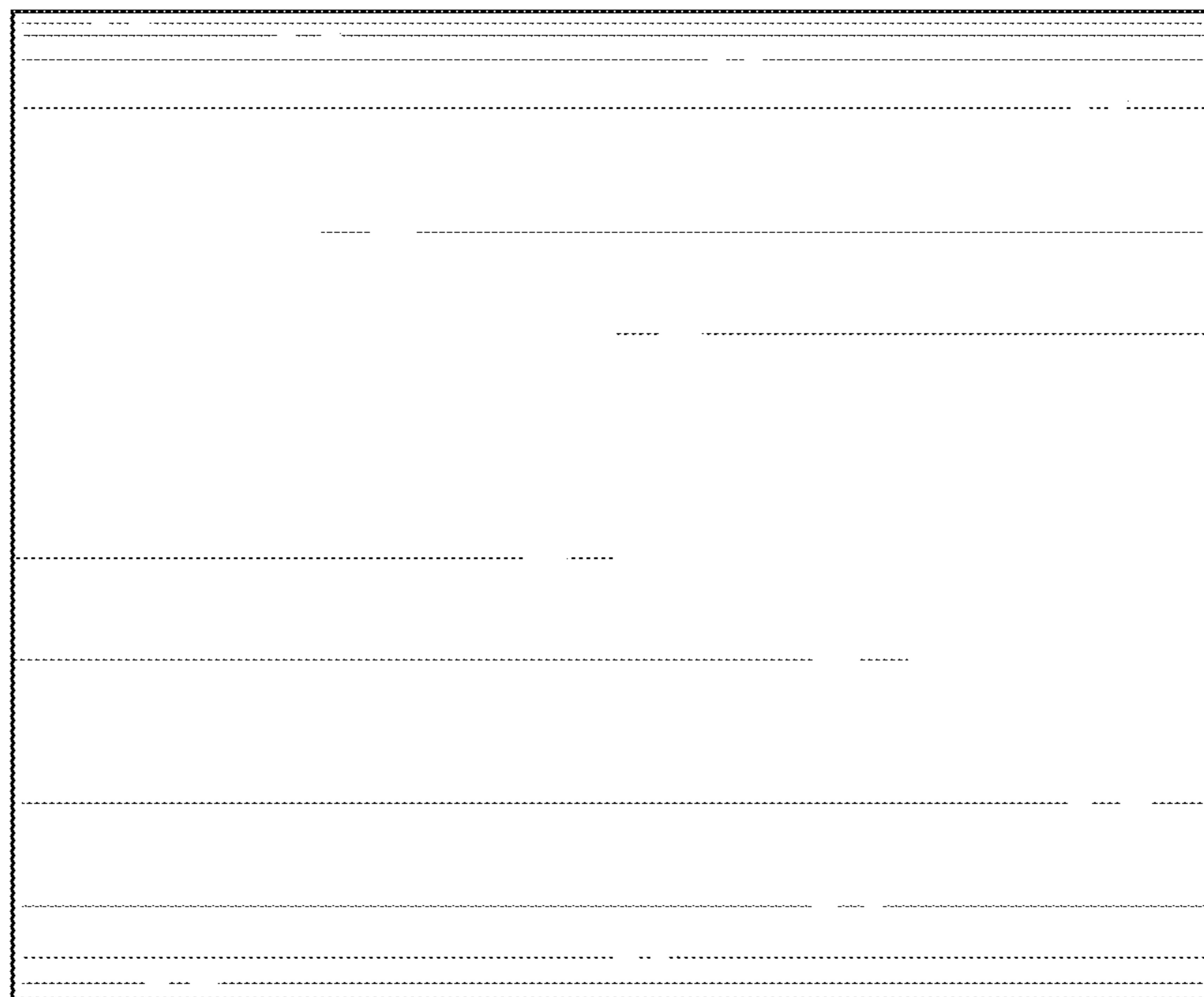

FIG. 7