



US00D913583S

(12) **United States Design Patent** (10) **Patent No.:** **US D913,583 S**  
**Leon Duque et al.** (45) **Date of Patent:** **\*\* \*Mar. 16, 2021**

- (54) **VAPORIZER DEVICE**
- (71) Applicant: **PAX Labs, Inc.**, San Francisco, CA (US)
- (72) Inventors: **Esteban Leon Duque**, Berkeley, CA (US); **James Monsees**, San Francisco, CA (US); **Brandon Cheung**, San Francisco, CA (US); **Steven Christensen**, Burlingame, CA (US)
- (73) Assignee: **PAX Labs, Inc.**, San Francisco, CA (US)

595,070 A 12/1897 Oldenbusch  
 720,007 A 2/1903 Dexter  
 799,844 A 9/1905 Fuller  
 968,160 A 8/1910 Johnson  
 969,076 A 8/1910 Pender  
 1,067,531 A 7/1913 MacGregor  
 (Continued)

**FOREIGN PATENT DOCUMENTS**

AU 2014206215 A1 8/2014  
 AU 2014208287 A1 8/2014  
 (Continued)

**OTHER PUBLICATIONS**

Detailed Pax Vaporizer Review. by John Ryan. dated Oct 10, 2013. found online [Jun. 16, 2020] <https://extremevaporizers.com/detailed-pax-vaporizer-review>.\*

(Continued)

*Primary Examiner* — Marissa J Cash  
 (74) *Attorney, Agent, or Firm* — Mintz Levin Cohn Ferris Glovsky and Popeo, P.C.

- (\*) Notice: This patent is subject to a terminal disclaimer.
- (\*\*) Term: **15 Years**
- (21) Appl. No.: **29/634,332**
- (22) Filed: **Jan. 19, 2018**

**Related U.S. Application Data**

- (62) Division of application No. 29/568,343, filed on Jun. 16, 2016, now Pat. No. Des. 849,996.
- (51) **LOC (13) Cl.** ..... **27-02**
- (52) **U.S. Cl.**  
USPC ..... **D27/194**
- (58) **Field of Classification Search**  
USPC ..... D27/100, 101, 139–194; D23/202; D13/118, 119; D19/115, 116, 162, 163, D19/164; D7/300; D9/444, 445  
CPC ..... A24F 47/008; A24F 47/002; A24F 15/18; A24F 47/00  
See application file for complete search history.

(57) **CLAIM**

The ornamental design for a vaporizer device, as shown and described.

**DESCRIPTION**

FIG. 1 is a bottom, front, and side perspective view of a vaporizer device of our design;  
 FIG. 2 is a top, rear, and side perspective view thereof;  
 FIG. 3 is a front plan view thereof;  
 FIG. 4 is a rear plan view thereof;  
 FIG. 5 is a side view thereof; the opposite side view is the same;  
 FIG. 6 is a top plan view thereof; and,  
 FIG. 7 is a bottom plan view thereof.  
 The broken lines show portions of the vaporizer device that form no part of the claimed design.

- (56) **References Cited**  
U.S. PATENT DOCUMENTS

374,584 A 12/1887 Cook  
 576,653 A 2/1897 Bowlby

**1 Claim, 4 Drawing Sheets**

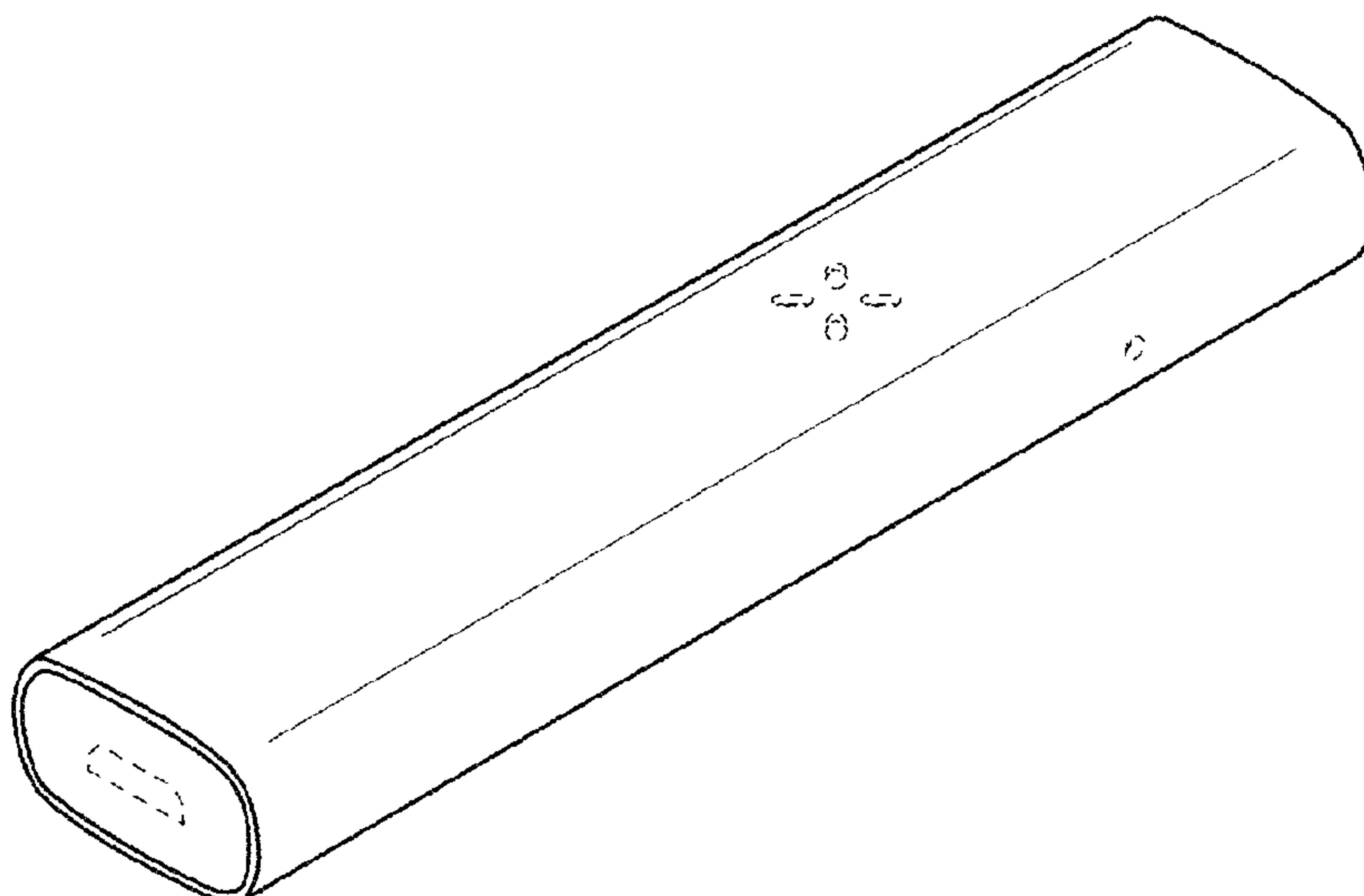

(56)

References Cited

U.S. PATENT DOCUMENTS

1,163,183 A	12/1915	Stoll	4,794,323 A	12/1988	Zhou et al.
1,299,162 A	4/1919	Fisher	4,798,310 A	1/1989	Kasai et al.
1,485,260 A	2/1924	Fritz	4,813,536 A	3/1989	Willis
1,505,748 A	8/1924	Louis	4,819,665 A	4/1989	Roberts et al.
1,552,877 A	9/1925	Phillipps et al.	4,830,028 A	5/1989	Lawson et al.
1,632,335 A	6/1927	Hiering	D301,837 S	6/1989	Peterson et al.
1,706,244 A	3/1929	Louis	4,836,224 A	6/1989	Lawson et al.
1,845,340 A	2/1932	Ritz	4,846,199 A	7/1989	Rose
1,972,118 A	9/1934	McDill	4,848,374 A	7/1989	Chard et al.
1,998,683 A	4/1935	Montgomery	4,848,563 A	7/1989	Robbins
2,031,363 A	2/1936	Elof	D302,659 S	8/1989	Peterson et al.
2,039,559 A	5/1936	Segal	D303,722 S	9/1989	Marlow et al.
2,104,266 A	1/1938	McCormick	4,870,748 A	10/1989	Hensgen et al.
2,159,698 A	5/1939	Harris et al.	D304,771 S	11/1989	Katayama
2,177,636 A	10/1939	Coffelt et al.	4,893,639 A	1/1990	White
2,195,260 A	3/1940	Rasener	4,896,683 A	1/1990	Cohen et al.
2,231,909 A	2/1941	Hempal	4,907,606 A	3/1990	Lilja et al.
2,327,120 A	8/1943	McCoon	4,924,883 A	5/1990	Perfetti et al.
D142,178 S	8/1945	Becwar	4,938,236 A	7/1990	Banerjee et al.
2,460,427 A	2/1949	Musselman et al.	4,941,483 A	7/1990	Ridings et al.
2,483,304 A	9/1949	Rudolf	4,944,317 A	7/1990	Thal
2,502,561 A	4/1950	Ludwig	D310,171 S	8/1990	Cusenza
2,765,949 A	10/1956	Swan	4,945,929 A	8/1990	Egilmex
2,830,597 A	4/1958	Kumpli	4,947,874 A	8/1990	Brooks et al.
2,860,638 A	11/1958	Bartolomeo	4,947,875 A	8/1990	Brooks et al.
2,897,958 A	8/1959	Tarleton et al.	D310,349 S	9/1990	Rowen
2,935,987 A	5/1960	Ackerbauer	4,955,397 A	9/1990	Johnson et al.
2,956,569 A	10/1960	Adams	4,974,609 A	12/1990	Southwick et al.
D194,088 S	11/1962	Mann	4,984,588 A	1/1991	Stewart, Jr.
3,085,145 A	4/1963	Wray	D315,032 S	2/1991	Hayes
3,146,937 A	9/1964	Joseph	5,005,759 A	4/1991	Bouche
3,258,015 A	6/1966	Ellis et al.	5,019,122 A	5/1991	Clearman et al.
3,271,719 A	9/1966	Ovshinsky	5,020,548 A	6/1991	Farrier et al.
3,292,634 A	12/1966	Beucler	5,027,836 A	7/1991	Shannon et al.
D207,887 S	6/1967	Parsisson	5,031,646 A	7/1991	Lippiello et al.
3,373,915 A	3/1968	Anderson et al.	5,040,551 A	8/1991	Schlatter et al.
3,420,360 A	1/1969	Young	5,042,509 A	8/1991	Banerjee et al.
3,443,827 A	5/1969	Acker et al.	5,050,621 A	9/1991	Creighton et al.
3,456,645 A	7/1969	Brock	5,060,671 A	10/1991	Counts et al.
3,479,561 A	11/1969	Janning	5,065,776 A	11/1991	Lawson et al.
3,565,071 A	2/1971	Sanford Cobb et al.	5,076,297 A	12/1991	Farrier et al.
3,567,014 A	3/1971	Feigelman	5,101,838 A	4/1992	Schwartz et al.
3,675,661 A	7/1972	Weaver	5,105,831 A	4/1992	Banerjee et al.
3,707,017 A	12/1972	Paquette	5,105,836 A	4/1992	Gentry et al.
3,779,770 A	12/1973	Alston et al.	5,105,838 A	4/1992	White et al.
3,792,704 A	2/1974	Parker	5,123,530 A	6/1992	Lee
3,815,597 A	6/1974	Goettelman	5,127,511 A	7/1992	Keen, Jr. et al.
3,861,523 A	1/1975	Fountain et al.	5,133,368 A	7/1992	Neumann et al.
3,941,300 A	3/1976	Troth	5,141,004 A	8/1992	Porenski
4,020,853 A	5/1977	Nuttall	5,144,962 A	9/1992	Counts et al.
4,049,005 A	9/1977	Hernandez et al.	5,148,817 A	9/1992	Houminer et al.
4,066,088 A	1/1978	Ensor	5,152,456 A	10/1992	Ross et al.
D250,485 S	12/1978	Cuthbertson	5,175,791 A	12/1992	Muderlak et al.
D255,548 S	6/1980	Grodin	5,183,062 A	2/1993	Clearman et al.
4,207,976 A	6/1980	Herman	D336,346 S	6/1993	Miller et al.
4,215,708 A	8/1980	Bron	5,224,498 A	7/1993	Deevi et al.
4,219,032 A	8/1980	Tabatznik et al.	5,228,460 A	7/1993	Sprinkel et al.
D260,690 S *	9/1981	Stutzer ..... D27/154	5,240,012 A	8/1993	Ehrman et al.
4,303,083 A	12/1981	Burruss, Jr.	5,249,586 A	10/1993	Morgan et al.
4,312,367 A	1/1982	Seeman	5,261,424 A	11/1993	Sprinkel, Jr.
4,347,855 A	9/1982	Lanzillotti et al.	5,269,237 A	12/1993	Baker et al.
4,391,285 A	7/1983	Burnett et al.	5,269,327 A	12/1993	Counts et al.
D271,255 S	11/1983	Rousseau	H1271 H	1/1994	Shouse
4,492,480 A	1/1985	Wadso et al.	D344,927 S	3/1994	Sands et al.
4,506,683 A	3/1985	Cantrell et al.	5,296,685 A	3/1994	Burstein et al.
4,519,319 A	5/1985	Howlett	5,303,720 A	4/1994	Banerjee et al.
4,520,938 A	6/1985	Finke	D346,581 S	5/1994	Tattari
D280,494 S	9/1985	Abel	5,322,075 A	6/1994	Deevi et al.
4,595,024 A	6/1986	Greene et al.	5,324,498 A	6/1994	Streusand et al.
4,625,737 A	12/1986	Keritsis et al.	5,345,951 A	9/1994	Serrano et al.
4,648,393 A	3/1987	Landis et al.	5,369,723 A	11/1994	Counts et al.
4,708,151 A	11/1987	Shelar	5,372,148 A	12/1994	McCafferty et al.
4,735,217 A	4/1988	Gerth et al.	5,388,574 A	2/1995	Lngebrethsen
4,771,796 A	9/1988	Myer	5,449,078 A	9/1995	Akers
4,793,365 A	12/1988	Sensabaugh, Jr. et al.	5,456,269 A	10/1995	Kollasch
			5,472,001 A	12/1995	Nicholson
			D367,605 S	3/1996	Moore
			5,497,791 A	3/1996	Bowen et al.
			D368,552 S	4/1996	Adams



(56)

## References Cited

## U.S. PATENT DOCUMENTS

5,529,078	A	6/1996	Rehder et al.	D450,662	S	11/2001	Kwok
D371,633	S	7/1996	Chenard	6,324,261	B1	11/2001	Merte
5,545,904	A	8/1996	Orbach	6,349,728	B1	2/2002	Pham
5,564,442	A	10/1996	MacDonald et al.	D454,079	S	3/2002	Fong
5,579,934	A	12/1996	Buono	6,381,739	B1	4/2002	Breternitz, Jr. et al.
5,591,368	A	1/1997	Fleischhauer et al.	6,386,371	B1	5/2002	Parsons
5,605,226	A	2/1997	Hernlein	6,407,371	B1	6/2002	Toya et al.
D379,810	S	6/1997	Giordano, Jr. et al.	6,418,938	B1	7/2002	Fleischhauer et al.
5,641,064	A	6/1997	Goserud	6,431,363	B1	8/2002	Hacker
D380,293	S	7/1997	Cudmore	6,443,146	B1	9/2002	Voges
5,649,552	A	7/1997	Cho et al.	6,446,793	B1	9/2002	Layshock
D382,146	S	8/1997	Sandy	D465,660	S	11/2002	Doeing
5,666,977	A	9/1997	Higgins et al.	D465,731	S	11/2002	Brant et al.
5,666,978	A	9/1997	Counts et al.	6,510,982	B2	1/2003	White et al.
5,708,258	A	1/1998	Counts et al.	D471,104	S	3/2003	Hunt
5,730,118	A	3/1998	Hermanson	6,532,965	B1	3/2003	Abhulimen et al.
5,730,158	A	3/1998	Collins et al.	6,536,442	B2	3/2003	St. Charles et al.
5,746,587	A	5/1998	Racine et al.	6,542,065	B2	4/2003	Shrier et al.
D397,504	S	8/1998	Zelenik	6,557,708	B2	5/2003	Polacco
D398,150	S	9/1998	Vonarburg	6,595,362	B2	7/2003	Penney et al.
5,807,509	A	9/1998	Shrier et al.	6,598,607	B2	7/2003	Adiga et al.
5,810,164	A	9/1998	Rennecamp	D477,920	S	8/2003	McCarty et al.
5,819,756	A	10/1998	Mielordt	D478,569	S	8/2003	Hussaini et al.
D401,215	S	11/1998	Moskowitz et al.	D478,897	S	8/2003	Tsuge
5,845,649	A	12/1998	Saito et al.	6,603,924	B2	8/2003	Brown et al.
D405,007	S	2/1999	Naas, Sr.	6,606,998	B1	8/2003	Gold
D405,413	S	2/1999	Segers	6,612,404	B2	9/2003	Sweet et al.
5,865,185	A	2/1999	Collins et al.	6,615,840	B1	9/2003	Fournier et al.
5,865,186	A	2/1999	Volsey, II	6,622,867	B2	9/2003	Menceles
5,878,752	A	3/1999	Adams et al.	D481,314	S	10/2003	Noonan
5,881,884	A	3/1999	Podosek	6,637,430	B1	10/2003	Voges et al.
D407,978	S	4/1999	Petro	6,655,379	B2	12/2003	Clark et al.
5,894,841	A	4/1999	Voges	6,657,532	B1	12/2003	Shrier et al.
D411,332	S	6/1999	Zelenik	D485,639	S	1/2004	Stronski
D412,279	S	7/1999	Brice	6,672,762	B1	1/2004	Faircloth et al.
D412,486	S	8/1999	Gray et al.	6,688,313	B2	2/2004	Wrenn et al.
5,931,828	A	8/1999	Durkee	6,707,274	B1	3/2004	Karr
5,934,289	A	8/1999	Watkins et al.	6,708,846	B1	3/2004	Fuchs et al.
5,938,018	A	8/1999	Keaveney et al.	6,726,006	B1	4/2004	Funderburk et al.
5,944,025	A	8/1999	Cook et al.	6,743,030	B2	6/2004	Lin et al.
5,954,979	A	9/1999	Counts et al.	6,747,573	B1	6/2004	Gerlach et al.
D414,893	S	10/1999	Moore	6,752,649	B2	6/2004	Arkin et al.
5,967,310	A	10/1999	Hill	D494,315	S	8/2004	Cartier
5,975,415	A	11/1999	Zehnal	6,769,436	B2	8/2004	Horian
5,979,460	A	11/1999	Matsumura	6,772,756	B2	8/2004	Shayan
5,979,548	A	11/1999	Rhodes et al.	D495,599	S	9/2004	Biesecker
5,994,025	A	11/1999	Iwasa et al.	6,799,576	B2	10/2004	Farr
5,996,589	A	12/1999	St. Charles	6,803,545	B2	10/2004	Blake et al.
6,024,097	A	2/2000	Von Wielligh	6,803,744	B1	10/2004	Sabo
6,026,820	A	2/2000	Baggett, Jr. et al.	6,805,545	B2	10/2004	Slaboden
6,040,560	A	3/2000	Fleischhauer et al.	6,810,883	B2	11/2004	Felter et al.
D422,884	S	4/2000	Lafond	D500,301	S	12/2004	Deguchi
6,053,176	A	4/2000	Adams et al.	D500,302	S	12/2004	Deguchi
D424,236	S	5/2000	Reed	6,827,573	B2	12/2004	St. Charles et al.
D424,739	S	5/2000	Ross	6,854,470	B1	2/2005	Pu
6,089,857	A	7/2000	Matsuura et al.	6,874,507	B2	4/2005	Farr
6,095,153	A	8/2000	Kessler et al.	6,889,687	B1	5/2005	Olsson
6,102,036	A	8/2000	Slutsky et al.	D505,922	S	6/2005	Mayo et al.
6,119,684	A	9/2000	Nohl et al.	D506,447	S	6/2005	Mayo et al.
6,125,853	A	10/2000	Susa et al.	D506,731	S	6/2005	Mayo et al.
D433,532	S	11/2000	Higgins et al.	6,909,840	B2	6/2005	Harwig et al.
6,155,268	A	12/2000	Takeuchi	D507,244	S	7/2005	Mayo et al.
6,164,287	A	12/2000	White	6,923,327	B1	8/2005	Cohen
D436,686	S	1/2001	Fujisawa	6,923,890	B2	8/2005	Ricatto et al.
6,196,232	B1	3/2001	Chkadua	6,954,979	B2	10/2005	Logan
6,216,705	B1	4/2001	Ossepian	D513,181	S	12/2005	Bloom et al.
D442,328	S	5/2001	Barnes	6,994,096	B2	2/2006	Rostami et al.
6,234,169	B1	5/2001	Bulbrook et al.	7,000,775	B2	2/2006	Gelardi et al.
6,239,687	B1	5/2001	Shrier et al.	7,015,796	B2	3/2006	Snyder
6,265,789	B1	7/2001	Honda et al.	7,019,491	B2	3/2006	Bozzone et al.
D446,499	S	8/2001	Andre et al.	7,025,066	B2	4/2006	Lawson et al.
D447,276	S	8/2001	Gustafson	D521,445	S	5/2006	Liu
6,269,966	B1	8/2001	Pallo et al.	6,994,096	B2	2/2006	Rostami et al.
6,310,752	B1	10/2001	Shrier et al.	7,000,775	B2	2/2006	Gelardi et al.
D450,313	S	11/2001	Koinuma	7,015,796	B2	3/2006	Snyder
				7,019,491	B2	3/2006	Bozzone et al.
				7,025,066	B2	4/2006	Lawson et al.
				D521,445	S	5/2006	Liu
				7,049,926	B2	5/2006	Shrier et al.
				D523,171	S	6/2006	Mitten et al.
				D525,948	S	8/2006	Blair et al.
				7,082,825	B2	8/2006	Aoshima et al.
				D528,992	S	9/2006	Hobart et al.
				D529,044	S	9/2006	Andre et al.
				7,109,876	B2	9/2006	Smith et al.



(56)

References Cited

U.S. PATENT DOCUMENTS

D530,340 S	10/2006	Andre et al.	D611,409 S	3/2010	Green et al.
D531,190 S	10/2006	Lee et al.	D611,944 S	3/2010	Kujawski et al.
7,117,707 B2	10/2006	Adams et al.	7,669,596 B2	3/2010	Alston
D532,776 S	11/2006	Griffin	D616,753 S	6/2010	Beam et al.
D532,927 S *	11/2006	Sann ..... D27/101	7,726,320 B2	6/2010	Robinson et al.
D534,921 S	1/2007	Andre et al.	D619,003 S	7/2010	Benoit-Gonin et al.
D535,261 S	1/2007	Daniels	7,753,055 B2	7/2010	Bryman
D535,308 S	1/2007	Andre et al.	D621,357 S	8/2010	Dong
7,173,222 B2	2/2007	Cox et al.	7,767,698 B2	8/2010	Warchol et al.
7,185,651 B2	3/2007	Alston et al.	D624,012 S	9/2010	de Medeiros et al.
7,185,659 B2	3/2007	Sharpe	D624,238 S	9/2010	Turner
D539,813 S	4/2007	Chen	D624,378 S	9/2010	Wysopal
D540,131 S	4/2007	Swann	7,793,860 B2	9/2010	Bankers et al.
D540,687 S	4/2007	Egawa	7,793,861 B2	9/2010	Bankers et al.
D540,749 S	4/2007	Kaule	7,801,573 B2	9/2010	Yazdi et al.
7,214,075 B2	5/2007	He et al.	D624,880 S	10/2010	Felegy, Jr. et al.
D544,643 S	6/2007	Lin	7,813,832 B2	10/2010	Sundar
D545,303 S	6/2007	Chang	7,814,905 B2	10/2010	Schuler et al.
7,234,593 B2	6/2007	Fath et al.	7,815,332 B1	10/2010	Smith
D545,904 S	7/2007	Chen et al.	D627,962 S	11/2010	Mudrick
D546,782 S	7/2007	Poulet et al.	7,832,397 B2	11/2010	Lipowicz
D547,002 S	7/2007	Lin	7,832,410 B2	11/2010	Hon
D551,548 S	9/2007	Didier	7,845,359 B2	12/2010	Montaser
D551,970 S	10/2007	Didier	D631,055 S	1/2011	Gilbert et al.
D553,458 S	10/2007	Hood	D631,458 S	1/2011	Liao et al.
7,275,941 B1	10/2007	Bushby	D631,883 S	2/2011	Maier
D555,284 S *	11/2007	Fath ..... D27/189	D631,885 S	2/2011	Maier
D556,154 S	11/2007	Poulet et al.	D632,958 S	2/2011	Fuchs
7,290,549 B2	11/2007	Banerjee et al.	7,886,507 B2	2/2011	McGuinness, Jr.
D557,209 S	12/2007	Ahlgren et al.	7,891,666 B2	2/2011	Kuenzler et al.
D558,060 S	12/2007	Milan Sir	D633,386 S	3/2011	Taber et al.
D559,838 S	1/2008	Yuba et al.	D634,065 S	3/2011	Borushek et al.
D562,151 S	2/2008	Larocca et al.	D634,200 S	3/2011	Taber et al.
D562,761 S	2/2008	Ueda et al.	D634,735 S	3/2011	Maier
D565,496 S	4/2008	Disla	D635,142 S	3/2011	Borislow
D568,298 S	5/2008	Lundgren et al.	7,905,230 B2	3/2011	Schuler et al.
D569,727 S	5/2008	Moretti	7,905,236 B2	3/2011	Bryman et al.
7,367,334 B2	5/2008	Faison, Jr. et al.	7,913,686 B2	3/2011	Hughes et al.
7,374,048 B2	5/2008	Mazurek	D638,430 S	5/2011	Lee et al.
D571,202 S	6/2008	Vogt	D639,303 S	6/2011	Ni et al.
D571,556 S	6/2008	Raile	D639,782 S	6/2011	Kim
D573,022 S	7/2008	Berman	D641,718 S	7/2011	Sakai
D573,474 S	7/2008	Beam et al.	D642,330 S	7/2011	Turner
D574,240 S	8/2008	Szczesniak	D643,807 S	8/2011	Jiang
7,415,982 B1	8/2008	Sheridan	D644,375 S	8/2011	Zhou
D576,619 S	9/2008	Udagawa et al.	7,987,846 B2	8/2011	Hale et al.
D577,019 S	9/2008	Udagawa et al.	7,988,034 B2	8/2011	Pezzoli
D577,150 S	9/2008	Bryman et al.	8,003,080 B2	8/2011	Rabinowitz et al.
D577,591 S	9/2008	Bouroullec et al.	D645,817 S *	9/2011	Sasada ..... D13/108
7,428,905 B2	9/2008	Mua	D647,247 S	10/2011	Jones
7,434,584 B2	10/2008	Steinberg	8,040,142 B1	10/2011	Bokma et al.
D579,934 S	11/2008	Okamoto et al.	8,042,550 B2	10/2011	Urtsev et al.
D580,756 S	11/2008	Seebold	D648,726 S	11/2011	Behar et al.
7,451,877 B2	11/2008	Koga et al.	D649,708 S	11/2011	Oneil
D584,149 S	1/2009	Lohrman et al.	D649,932 S	12/2011	Symons
D585,077 S	1/2009	Sheba et al.	D650,737 S	12/2011	Hamilton
7,488,171 B2	2/2009	St. Charles et al.	D651,211 S	12/2011	Lee et al.
D588,741 S	3/2009	Murdaugh, III et al.	8,079,361 B2	12/2011	Schuler et al.
D589,941 S	4/2009	Maier et al.	8,079,371 B2	12/2011	Robinson et al.
D590,988 S	4/2009	Hon	8,080,975 B2	12/2011	Bessa et al.
D590,989 S	4/2009	Hon	8,091,558 B2	1/2012	Martzel
D590,990 S	4/2009	Hon	D653,803 S	2/2012	Timmermans
D590,991 S	4/2009	Hon	D655,708 S	3/2012	Frank
D591,758 S	5/2009	Lee	D656,496 S	3/2012	Andre et al.
7,530,352 B2	5/2009	Childers et al.	8,141,701 B2	3/2012	Hodges
7,546,703 B2	6/2009	Johnske et al.	8,156,944 B2	4/2012	Han
D599,670 S	9/2009	Qin	8,157,918 B2	4/2012	Becker et al.
7,581,540 B2	9/2009	Hale et al.	8,170,623 B2	5/2012	Dorogusker et al.
7,621,403 B2	11/2009	Althoff et al.	D661,889 S	6/2012	Wu
D605,509 S	12/2009	Leonardis	D661,991 S	6/2012	Brummelhuis et al.
D606,505 S	12/2009	Seflic et al.	8,205,622 B2	6/2012	Pan
D606,864 S	12/2009	Robinson	D664,146 S	7/2012	Hoehn et al.
7,633,270 B2	12/2009	Wong et al.	D664,636 S	7/2012	Robinson et al.
7,644,823 B2	1/2010	Gelardi et al.	D664,920 S	8/2012	Huang
D610,588 S	2/2010	Chen	D665,346 S	8/2012	Kumagai et al.
			D665,734 S	8/2012	Fitch et al.
			D666,144 S	8/2012	Brand et al.
			8,251,060 B2	8/2012	White et al.
			D669,899 S	10/2012	Cheng



(56)

## References Cited

## U.S. PATENT DOCUMENTS

8,282,995 B2	10/2012	Calzia et al.	8,707,965 B2	4/2014	Newton
D670,272 S	11/2012	Suzuki	D704,629 S	5/2014	Liu
D670,659 S	11/2012	Ishikawa et al.	D704,634 S	5/2014	Eidelman et al.
8,308,624 B2	11/2012	Travers et al.	D705,719 S	5/2014	Wong
8,314,235 B2	11/2012	Dixit et al.	D705,918 S	5/2014	Robinson et al.
D672,351 S	12/2012	Camacho et al.	8,714,150 B2	5/2014	Alelov
D672,714 S	12/2012	Brandys et al.	8,714,161 B2	5/2014	Liu
D672,715 S	12/2012	Brunner et al.	8,733,345 B2	5/2014	Siller
8,322,350 B2	12/2012	Lipowicz	8,733,346 B2	5/2014	Rinker
D674,182 S	1/2013	Copeland et al.	D707,389 S	6/2014	Liu
D674,748 S	1/2013	Ferber et al.	D707,627 S	6/2014	Brunner et al.
8,344,693 B2	1/2013	Budziszek et al.	8,739,788 B2	6/2014	Yomtov
D675,777 S	2/2013	Wu	8,741,348 B2	6/2014	Hansson et al.
D676,741 S	2/2013	van Landsveld et al.	8,752,545 B2	6/2014	Buchberger
D676,810 S	2/2013	Smith et al.	8,752,557 B2	6/2014	Lipowicz
8,371,310 B2	2/2013	Brenneise	8,757,169 B2	6/2014	Gysland
8,375,947 B2	2/2013	Alston et al.	D708,571 S	7/2014	Ji et al.
8,375,957 B2	2/2013	Hon	D708,727 S	7/2014	Postma
8,381,739 B2	2/2013	Gonda	D709,766 S	7/2014	Miceli et al.
8,387,612 B2	3/2013	Damani et al.	D709,823 S	7/2014	Corley et al.
8,393,331 B2	3/2013	Hon	8,770,187 B2	7/2014	Murphy
8,402,978 B2	3/2013	Karles et al.	8,781,307 B2	7/2014	Buzzetti
D679,999 S	4/2013	Miceli et al.	8,790,556 B2	7/2014	Bundren et al.
D680,000 S	4/2013	Miceli et al.	8,794,231 B2	8/2014	Thorens et al.
D680,263 S	4/2013	Braley	8,794,244 B2	8/2014	Hammel et al.
8,424,539 B2	4/2013	Braunshiteyn et al.	8,794,245 B1	8/2014	Scatterday
D681,445 S	5/2013	van Landsveld et al.	8,794,434 B2	8/2014	Scatterday et al.
D681,465 S	5/2013	Cox et al.	8,807,140 B1	8/2014	Scatterday
D681,466 S	5/2013	Cox et al.	8,809,261 B2	8/2014	Elsohly et al.
D682,090 S	5/2013	Scatterday	8,813,747 B2	8/2014	Gibson et al.
D682,698 S	5/2013	Young	8,813,759 B1	8/2014	Horian
D682,841 S	5/2013	Suetake et al.	D712,347 S	9/2014	Awiszus et al.
8,443,534 B2	5/2013	Goodfellow et al.	D714,147 S	9/2014	Lindstrom, Sr.
D684,683 S	6/2013	Curti et al.	8,820,330 B2	9/2014	Bellinger et al.
8,464,867 B2	6/2013	Holloway et al.	8,829,395 B2	9/2014	Bao
D686,336 S	7/2013	Horian	D714,728 S	10/2014	Gentil
D686,987 S	7/2013	Vanstone et al.	8,851,068 B2	10/2014	Cohen et al.
D687,042 S	7/2013	Yoneta et al.	8,851,081 B2	10/2014	Fernando et al.
8,479,747 B2	7/2013	O'Connell	8,851,083 B2	10/2014	Oglesby et al.
8,490,629 B1	7/2013	Shenassa et al.	8,857,446 B2	10/2014	Wu
8,495,998 B2	7/2013	Schennum	8,863,752 B2	10/2014	Hon
D687,299 S	8/2013	Peykoff et al.	8,869,792 B1	10/2014	Lee
D688,128 S	8/2013	Krause	8,881,737 B2	11/2014	Collett et al.
8,499,766 B1	8/2013	Newton	8,881,738 B2	11/2014	Bryman
8,511,318 B2	8/2013	Hon	8,893,726 B2	11/2014	Hon
D689,818 S	9/2013	Sasada	8,897,628 B2	11/2014	Conley et al.
D690,461 S	9/2013	Chen	D718,621 S	12/2014	Mitchell et al.
8,539,959 B1	9/2013	Scatterday	D718,723 S	12/2014	Clymer et al.
8,541,401 B2	9/2013	Mishra et al.	D718,933 S	12/2014	Brown, Jr.
D691,324 S	10/2013	Saliman	D719,701 S	12/2014	Scatterday
D692,615 S	10/2013	Verleur	D720,095 S	12/2014	Alima
8,550,069 B2	10/2013	Alelov	D720,496 S	12/2014	Alima
8,552,691 B2	10/2013	Wu	D720,497 S	12/2014	Alima
D693,054 S	11/2013	Verleur	8,899,238 B2	12/2014	Robinson et al.
D693,221 S	11/2013	Ramsey et al.	8,899,240 B2	12/2014	Mass
D693,684 S	11/2013	Ramsey et al.	8,905,040 B2	12/2014	Scatterday et al.
D693,685 S	11/2013	Ramsey et al.	8,910,630 B2	12/2014	Todd
D694,109 S	11/2013	Tanner	8,910,639 B2	12/2014	Chang et al.
D694,110 S	11/2013	Tanner	8,910,640 B2	12/2014	Sears et al.
8,578,942 B2	11/2013	Schennum	8,910,641 B2	12/2014	Hon
8,578,943 B2	11/2013	Luan et al.	8,910,783 B2	12/2014	Liu
D695,450 S	12/2013	Benassayag et al.	8,915,254 B2	12/2014	Monsees et al.
D696,051 S	12/2013	Scatterday	8,919,561 B2	12/2014	Boisseau
8,596,460 B2	12/2013	Scatterday	D721,202 S	1/2015	Liu
D697,029 S	1/2014	Chiu	D721,577 S	1/2015	Scatterday
D700,136 S	2/2014	Morris et al.	8,925,555 B2	1/2015	Monsees et al.
D700,372 S	2/2014	Altman	8,928,277 B2	1/2015	Xiang et al.
8,646,462 B2	2/2014	Yamada et al.	8,931,492 B2	1/2015	Scatterday
D700,572 S	3/2014	Esses	D721,972 S	2/2015	Brewer et al.
8,671,952 B2	3/2014	Winterson et al.	D722,023 S	2/2015	Brunner et al.
8,678,012 B2	3/2014	Li et al.	8,948,578 B2	2/2015	Buchberger
D703,680 S	4/2014	Lin	8,950,395 B2	2/2015	Schennum
8,689,789 B2	4/2014	Andrus et al.	8,955,522 B1	2/2015	Bowen et al.
8,689,805 B2	4/2014	Hon	8,960,199 B2	2/2015	Zhuang et al.
8,695,794 B2	4/2014	Scatterday	8,961,492 B2	2/2015	Imran et al.
			8,963,725 B2	2/2015	Xiang
			D723,735 S	3/2015	Liu
			D723,736 S	3/2015	Liu
			D723,737 S	3/2015	Liu



(56)

References Cited

U.S. PATENT DOCUMENTS

D723,919 S	3/2015	Taber et al.	9,167,852 B2	10/2015	Xiu
D724,037 S	3/2015	Yoshioka	9,167,853 B2	10/2015	Xiang
D725,124 S	3/2015	Lin et al.	D742,492 S	11/2015	Robinson et al.
D725,310 S *	3/2015	Eksouzian ..... D27/101	D742,624 S	11/2015	Meyers
D725,823 S	3/2015	Scatterday et al.	D743,099 S	11/2015	Oglesby
8,967,382 B2	3/2015	Liu	D743,335 S	11/2015	Chang
8,973,587 B2	3/2015	Liu	D743,401 S	11/2015	Shimano et al.
8,975,764 B1	3/2015	Abehasera	D744,159 S	11/2015	Lukas
8,978,663 B2	3/2015	Newton	9,185,937 B2	11/2015	Liu
8,991,402 B2	3/2015	Bowen et al.	9,197,726 B2	11/2015	Stanimirovic et al.
8,993,836 B2	3/2015	Tissier et al.	D744,342 S	12/2015	Blasko et al.
D726,727 S	4/2015	Holz et al.	D744,419 S	12/2015	Bowen et al.
9,004,073 B2	4/2015	Tucker et al.	D744,696 S	12/2015	Malhi
9,010,335 B1	4/2015	Scatterday	D745,004 S	12/2015	Kim
9,016,274 B1	4/2015	White	D745,388 S	12/2015	Taylor
9,018,899 B2	4/2015	Xiang	D746,291 S	12/2015	Solomon et al.
D728,855 S	5/2015	Liu	9,198,463 B2	12/2015	Liu
D729,030 S	5/2015	Novick et al.	9,198,464 B2	12/2015	Liu
D729,277 S	5/2015	Uchida	9,198,466 B2	12/2015	Liu
D729,366 S	5/2015	Kauss et al.	9,204,670 B2	12/2015	Liu
D729,439 S	5/2015	Scatterday	9,215,895 B2	12/2015	Bowen et al.
D729,444 S	5/2015	Leidel	9,220,302 B2	12/2015	DePiano et al.
D729,445 S	5/2015	Leidel	9,220,303 B2	12/2015	Li et al.
D730,282 S	5/2015	Miller et al.	D747,035 S	1/2016	Moradian
D730,571 S	5/2015	Chen	D747,265 S	1/2016	Marini
D730,572 S	5/2015	Leidel	D747,546 S	1/2016	Liu
9,022,026 B2	5/2015	Fang	D747,603 S	1/2016	Gaddis
9,022,039 B2	5/2015	Hearn	D747,722 S	1/2016	Webb
9,025,291 B2	5/2015	Xiang	D747,852 S	1/2016	Meyers
9,028,808 B2	5/2015	Huland	D748,329 S	1/2016	Bagai et al.
9,032,968 B2	5/2015	Glasberg et al.	9,226,525 B2	1/2016	Liu
9,038,626 B2	5/2015	Yamada et al.	9,226,526 B2	1/2016	Liu
9,038,642 B2	5/2015	Liu	9,233,217 B2	1/2016	Jones
D731,114 S	6/2015	Leidel	9,240,695 B2	1/2016	Xiang
D733,050 S	6/2015	Chiang	9,240,697 B2	1/2016	Xiang
D733,142 S	6/2015	Solomon et al.	D748,852 S	2/2016	Wu
D733,356 S	6/2015	Leidel	D748,853 S	2/2016	Seibel et al.
9,046,278 B2	6/2015	Koller	D749,260 S	2/2016	Wu
9,050,431 B2	6/2015	Turner et al.	D749,261 S	2/2016	Chen
9,055,617 B2	6/2015	Thorens et al.	D749,505 S	2/2016	Verleur et al.
9,055,770 B2	6/2015	Liu	D749,510 S	2/2016	Liu
9,060,388 B2	6/2015	Liu	D749,781 S	2/2016	Lane
9,060,548 B2	6/2015	Zheng et al.	D750,320 S	2/2016	Verleur et al.
9,066,543 B2	6/2015	Cameron	D750,321 S	2/2016	Chen
D734,259 S	7/2015	Cepress et al.	9,247,773 B2	2/2016	Memari et al.
9,072,321 B2	7/2015	Liu	9,254,002 B2	2/2016	Chong et al.
9,072,322 B2	7/2015	Liu	9,254,005 B2	2/2016	Liu
9,078,472 B2	7/2015	Liu	9,255,277 B2	2/2016	Bakker et al.
9,078,473 B2	7/2015	Worm et al.	D750,835 S	3/2016	Wei
9,078,474 B2	7/2015	Thompson	D751,250 S	3/2016	Vuong
9,078,475 B2	7/2015	Li et al.	D751,527 S	3/2016	Hinokio et al.
9,089,166 B1	7/2015	Scatterday	D751,755 S	3/2016	Van Riper
9,089,168 B2	7/2015	Liu	D751,757 S	3/2016	Stern
9,090,173 B2	7/2015	Oishi	D751,984 S	3/2016	Lin
D736,706 S	8/2015	Huang et al.	D752,277 S	3/2016	Liu
D736,995 S	8/2015	Recio	D752,278 S	3/2016	Verleur et al.
D737,508 S	8/2015	Liu	D752,279 S	3/2016	Liu
9,095,174 B2	8/2015	Capuano	D752,280 S	3/2016	Verleur et al.
9,095,175 B2	8/2015	Terry et al.	D752,281 S	3/2016	Alima
9,099,873 B2	8/2015	Xiang	D752,282 S	3/2016	Doster
9,101,729 B2	8/2015	Liu	D752,283 S	3/2016	Doster
9,113,659 B2	8/2015	Liu	D752,284 S	3/2016	Doster
D737,566 S	9/2015	Gaddis	D752,285 S	3/2016	Doster
D738,038 S	9/2015	Smith	D752,286 S	3/2016	Doster
D739,973 S	9/2015	Chao	D752,808 S	3/2016	Hearn
9,131,733 B2	9/2015	Liu	9,271,525 B2	3/2016	Liu
D741,001 S	10/2015	Alarcon et al.	9,271,526 B2	3/2016	Liu
D741,002 S	10/2015	Liu	9,271,529 B2	3/2016	Alima
D741,541 S	10/2015	Liu	9,272,103 B2	3/2016	Storz
D742,063 S *	10/2015	Recio ..... D27/141	9,277,768 B2	3/2016	Xiu
D742,064 S	10/2015	Leidel	9,277,769 B2	3/2016	Liu
9,155,336 B2	10/2015	Liu	9,281,705 B2	3/2016	Xiang
9,166,424 B2	10/2015	Oakley, Jr.	9,282,772 B2	3/2016	Tucker et al.
9,167,849 B2	10/2015	Adamic	9,282,773 B2	3/2016	Greim et al.
9,167,850 B2	10/2015	Liu	9,289,014 B2	3/2016	Tucker et al.
			9,295,286 B2	3/2016	Shin
			D753,090 S	4/2016	Langhammer et al.
			D753,338 S	4/2016	Chen
			D753,873 S	4/2016	Schuessler



(56)

References Cited

U.S. PATENT DOCUMENTS

D753,874 S	4/2016	Moreno Medina et al.	9,414,627 B2	8/2016	Liu
D754,917 S	4/2016	Salem	9,414,628 B2	8/2016	Liu
D754,919 S	4/2016	Alarcon et al.	9,415,929 B2	8/2016	Liu
9,301,545 B2	4/2016	Li et al.	9,417,107 B2	8/2016	Xiang
9,301,549 B2	4/2016	Liu	9,420,831 B2	8/2016	Liu
9,302,800 B2	4/2016	Holmes et al.	9,427,022 B2	8/2016	Levin et al.
9,302,825 B2	4/2016	Liu	9,427,023 B2	8/2016	Liu
9,308,336 B2	4/2016	Newton	9,427,024 B2	8/2016	Liu
9,312,687 B2	4/2016	Xiang	9,427,025 B2	8/2016	Liu
9,315,890 B1	4/2016	Frick et al.	9,427,026 B2	8/2016	Wu
9,320,300 B2	4/2016	Hon	D765,907 S	9/2016	Liu
D755,057 S	5/2016	Mutter	D766,503 S	9/2016	Liu
D755,506 S	5/2016	Neely, III et al.	D766,873 S *	9/2016	Washio ..... D14/214
D755,733 S	5/2016	Ikegaya et al.	D767,200 S	9/2016	Liu
D755,735 S	5/2016	Kashimoto	D767,201 S	9/2016	Starr
D756,030 S	5/2016	Chen	D767,820 S	9/2016	Jordan et al.
D756,031 S	5/2016	Wu	D767,821 S	9/2016	Clark et al.
D756,559 S	5/2016	Li	D767,822 S	9/2016	Jordan et al.
D756,776 S	5/2016	Orset	9,433,242 B1	9/2016	Buffone
D756,790 S	5/2016	Henriksson	9,438,049 B2	9/2016	Xiang
D757,352 S	5/2016	Bagai	9,438,051 B2	9/2016	Firman, II et al.
D757,353 S	5/2016	Nunnally et al.	9,439,455 B2	9/2016	Alarcon et al.
D757,357 S	5/2016	Helfrich	9,439,456 B2	9/2016	Liu
D757,545 S	5/2016	King	9,440,035 B2	9/2016	Chung
D757,690 S	5/2016	Lee et al.	9,451,790 B2	9/2016	Liu
D757,994 S	5/2016	Moradian	9,451,793 B2	9/2016	Zhou
D757,995 S	5/2016	Liu	9,455,579 B2	9/2016	Xiang
D758,004 S	5/2016	Freshwater et al.	D768,068 S	10/2016	Chen
9,326,547 B2	5/2016	Tucker et al.	D768,331 S	10/2016	Chen
9,326,549 B2	5/2016	Hon	D768,920 S *	10/2016	Jones ..... D27/189
9,332,787 B2	5/2016	Liu	D768,980 S	10/2016	Alexander
9,345,269 B2	5/2016	Liu	D769,518 S	10/2016	Liu
9,350,102 B2	5/2016	Wu	D769,519 S	10/2016	Chen
9,350,178 B2	5/2016	Xiang	D769,520 S	10/2016	Hua
9,350,181 B2	5/2016	Xiang	D769,830 S	10/2016	Clymer et al.
9,351,522 B2	5/2016	Safari	D770,088 S	10/2016	Abadi et al.
D758,647 S	6/2016	Liu	9,456,632 B2	10/2016	Hon
D758,649 S	6/2016	Liu	9,456,633 B2	10/2016	Liu
D758,650 S	6/2016	Wu	9,456,634 B2	10/2016	Wang et al.
D759,031 S	6/2016	Ozolins et al.	9,459,021 B2	10/2016	Greim et al.
D759,297 S	6/2016	Liu	9,462,832 B2	10/2016	Lord
D759,303 S *	6/2016	Afridi ..... D27/101	9,465,081 B2	10/2016	Xiang
D760,431 S	6/2016	Liu	9,474,305 B2	10/2016	Liu
9,357,802 B2	6/2016	Liu	D770,395 S	11/2016	Clymer et al.
9,360,379 B2	6/2016	Liu	D770,456 S	11/2016	Akana et al.
9,364,025 B2	6/2016	Liu	D770,676 S	11/2016	Bennett et al.
9,364,026 B2	6/2016	Liu	D770,678 S	11/2016	Shin
9,364,027 B2	6/2016	Hon	D770,679 S	11/2016	Weigensberg
9,364,800 B2	6/2016	Dubief	D771,219 S	11/2016	Gilbarte
9,365,312 B2	6/2016	Tritz	D771,307 S	11/2016	Wu
9,379,364 B2	6/2016	Alima	D771,308 S	11/2016	Saydar et al.
D760,645 S	7/2016	Chen	D772,477 S	11/2016	Shin
D760,952 S	7/2016	Mayor	D772,478 S	11/2016	Liu
D761,488 S	7/2016	Alarcon et al.	D772,479 S	11/2016	Stowers et al.
D761,999 S	7/2016	Liu	D772,480 S	11/2016	Hua
D762,000 S	7/2016	Liu	D772,879 S	11/2016	Eliyahu
D762,001 S	7/2016	Liu	D773,114 S	11/2016	Leidel et al.
D762,003 S *	7/2016	Lomeli ..... D27/163	D773,115 S	11/2016	Liu
D762,326 S	7/2016	Liu	D773,116 S	11/2016	Liu et al.
9,380,810 B2	7/2016	Rose et al.	9,480,285 B2	11/2016	Liu
9,380,812 B2	7/2016	Chung	9,480,286 B2	11/2016	Liu
9,383,053 B2	7/2016	Liu	9,497,993 B2	11/2016	Vallar
9,385,554 B2	7/2016	Xiang	9,497,994 B2	11/2016	Liu
9,386,803 B2	7/2016	Burke et al.	9,497,995 B2	11/2016	Liu
D763,203 S	8/2016	Ikegaya et al.	9,497,997 B2	11/2016	Wu
D763,204 S	8/2016	Ikegaya et al.	9,497,998 B2	11/2016	Chen
D763,502 S	8/2016	Verleur et al.	9,497,999 B2	11/2016	Lord
D763,691 S	8/2016	Marantis et al.	9,498,001 B2	11/2016	Wu
D764,098 S	8/2016	Liu	9,498,002 B1	11/2016	Soreide
D764,703 S	8/2016	Liu	9,498,588 B2	11/2016	Benassayag et al.
D765,307 S	8/2016	Liu	9,502,917 B2	11/2016	Xiang
D765,308 S	8/2016	Liu	9,504,278 B2	11/2016	Liu
D765,309 S	8/2016	Liu	9,504,279 B2	11/2016	Chen
9,408,416 B2	8/2016	Monsees et al.	D773,391 S	12/2016	Haarburger et al.
9,413,180 B2	8/2016	Liu	D773,727 S	12/2016	Eksouzian
			D773,729 S	12/2016	Jordan et al.
			D774,035 S	12/2016	Kao
			D774,247 S	12/2016	Chen
			D774,248 S	12/2016	Jordan et al.



(56)

References Cited

U.S. PATENT DOCUMENTS

D774,514 S	12/2016	Turksu et al.	9,615,605 B2	4/2017	Liu
D774,693 S	12/2016	Liu	9,615,606 B2	4/2017	Liu
D774,892 S	12/2016	Liu	9,615,607 B2	4/2017	Liu
D775,412 S	12/2016	Di Bari	9,620,958 B2	4/2017	Liu
D775,413 S	12/2016	Liu	9,622,511 B2	4/2017	Zhu
9,510,624 B2	12/2016	Li et al.	9,623,592 B2	4/2017	Liu
9,516,898 B2	12/2016	Liu	9,627,661 B2	4/2017	Liu
9,521,867 B2	12/2016	Xiang	9,629,391 B2	4/2017	Dube et al.
9,526,272 B2	12/2016	Liu	9,629,394 B2	4/2017	Aronie et al.
9,526,273 B2	12/2016	Liu	D785,859 S	5/2017	Pang
9,531,183 B2	12/2016	Xiang	D785,862 S	5/2017	Wu
D775,762 S	1/2017	Chen	D786,497 S	5/2017	Sudlow et al.
D776,051 S	1/2017	Wang	D786,789 S	5/2017	Jordan et al.
D776,162 S	1/2017	Beck et al.	D787,114 S	5/2017	Scott
D776,270 S	1/2017	Wilcox et al.	D788,362 S	5/2017	Qiu
D776,338 S *	1/2017	Lomeli ..... D27/163	9,635,886 B2	5/2017	Tu
D776,340 S	1/2017	Seibel et al.	9,641,208 B2	5/2017	Sela et al.
D776,659 S	1/2017	Hou	9,642,396 B2	5/2017	Liu
D776,869 S	1/2017	Heidl	9,642,397 B2	5/2017	Dai et al.
D777,372 S	1/2017	Liu	9,645,134 B1	5/2017	Farmen et al.
D777,976 S	1/2017	Mahlmeister	9,648,905 B2	5/2017	Levitz et al.
9,532,598 B2	1/2017	Liu	9,648,908 B1	5/2017	Rinehart et al.
9,532,599 B2	1/2017	Liu	9,648,909 B2	5/2017	Zhou et al.
9,532,601 B2	1/2017	Liu	9,655,383 B2	5/2017	Holzherr et al.
9,532,602 B2	1/2017	Liu	9,655,890 B2	5/2017	Hearn et al.
9,532,604 B2	1/2017	Conley et al.	9,661,878 B2	5/2017	Liu
9,532,605 B2	1/2017	Yamada et al.	9,663,266 B2	5/2017	Schwester
9,538,781 B2	1/2017	Zheng	D788,697 S	6/2017	Verleur et al.
9,538,783 B2	1/2017	Xiang	D789,201 S	6/2017	Yu
9,538,787 B2	1/2017	Liu	D790,122 S	6/2017	Hawes et al.
9,538,789 B2	1/2017	Liu	D790,126 S	6/2017	Bennett et al.
9,545,489 B2	1/2017	Turner et al.	D790,127 S	6/2017	Verleur
9,549,572 B2	1/2017	Dincer et al.	D790,129 S	6/2017	Bennett et al.
9,549,573 B2	1/2017	Monsees et al.	D790,465 S	6/2017	Zhao
9,554,596 B2	1/2017	Liu	D790,766 S	6/2017	Li
9,554,597 B2	1/2017	Liu	9,668,517 B2	6/2017	Liu
9,555,203 B2	1/2017	Terry et al.	9,668,518 B2	6/2017	Esses
D778,493 S	2/2017	Scott	9,668,519 B2	6/2017	Mishra et al.
D778,831 S	2/2017	Chen	9,668,520 B2	6/2017	Boldrini
D779,677 S	2/2017	Chen	9,668,521 B2	6/2017	Kuczaj
D779,719 S *	2/2017	Qiu ..... D27/101	9,668,522 B2	6/2017	Memari et al.
D780,179 S	2/2017	Bae et al.	9,668,523 B2	6/2017	Tucker et al.
D780,183 S	2/2017	Ferguson et al.	9,675,108 B2	6/2017	Liu
D780,372 S	2/2017	Liu	9,675,113 B2	6/2017	Liu
D780,373 S	2/2017	Bennett et al.	9,675,114 B2	6/2017	Timmermans
9,560,882 B2	2/2017	Xiang	9,675,115 B2	6/2017	Liu
9,565,873 B2	2/2017	Zheng	9,675,116 B2	6/2017	Liu
9,565,876 B2	2/2017	Tsai	9,675,117 B2	6/2017	Li et al.
9,572,372 B2	2/2017	Liu	9,675,118 B2	6/2017	Chen
9,572,373 B2	2/2017	Chen	9,681,687 B2	6/2017	Liu
9,572,374 B2	2/2017	Gabbay	9,681,688 B1	6/2017	Rinehart et al.
9,573,751 B2	2/2017	Liu	9,682,203 B2	6/2017	Dahne et al.
9,578,002 B2	2/2017	Wu	9,682,204 B2	6/2017	Matsumoto et al.
9,578,898 B2	2/2017	Liu	9,682,800 B2	6/2017	Xiang
D780,990 S	3/2017	Liu	9,687,025 B2	6/2017	Cyphert et al.
D780,991 S	3/2017	Liu	9,687,027 B2	6/2017	Poston et al.
D782,108 S	3/2017	Jordan et al.	9,687,028 B2	6/2017	Park
D782,728 S	3/2017	Pinder	9,687,029 B2	6/2017	Liu
D782,729 S	3/2017	Wright et al.	D792,021 S	7/2017	Beer et al.
9,591,876 B2	3/2017	Alima	D792,022 S	7/2017	Li
9,596,881 B2	3/2017	Chiolini et al.	D792,219 S	7/2017	Bueno Nunez
9,596,884 B2	3/2017	Liu	D792,643 S *	7/2017	Wong ..... D27/101
9,596,885 B2	3/2017	Liu	D792,644 S	7/2017	Jordan et al.
9,596,886 B2	3/2017	Liu	D792,957 S	7/2017	Starkenbourg
9,596,887 B2	3/2017	Newton	D793,004 S	7/2017	Liu
9,602,646 B2	3/2017	Stanimirovic et al.	9,693,584 B2	7/2017	Hearn et al.
9,603,198 B2	3/2017	Liu	9,693,586 B2	7/2017	Liu
9,603,386 B2	3/2017	Xiang	9,693,587 B2	7/2017	Plojoux et al.
9,603,387 B2	3/2017	Liu	9,693,588 B2	7/2017	Zhu
9,603,389 B2	3/2017	Chen	9,695,033 B1	7/2017	Alshouse et al.
9,603,390 B2	3/2017	Li et al.	9,700,074 B2	7/2017	Liu
D784,609 S	4/2017	Liu	9,700,075 B2	7/2017	Liu
D785,234 S	4/2017	Liu	9,700,076 B2	7/2017	Xiang
D785,237 S	4/2017	Wu	9,713,345 B2	7/2017	Farine et al.
9,609,893 B2	4/2017	Novak, III et al.	9,713,346 B2	7/2017	Hon
			9,714,878 B2	7/2017	Powers et al.
			D793,620 S	8/2017	Bennett et al.
			9,717,274 B2	8/2017	Daehne et al.
			9,717,275 B2	8/2017	Liu



(56)

References Cited

U.S. PATENT DOCUMENTS

9,717,276 B2	8/2017	Brammer et al.		D870,959 S *	12/2019	Leon Duque	D27/162
9,717,277 B2	8/2017	Mironov		D870,964 S *	12/2019	Lee	D27/194
9,717,278 B2	8/2017	Hon		D871,663 S *	12/2019	Lord	D27/101
9,717,279 B2	8/2017	Hon		D871,668 S *	12/2019	Lee	D27/194
9,723,872 B2	8/2017	Liu		10,517,331 B2 *	12/2019	Atkins	F22B 1/284
9,723,873 B2	8/2017	Liu		D872,355 S *	1/2020	Powell	D27/141
9,723,874 B2	8/2017	Liu		D877,971 S *	3/2020	Bowen	D27/101
9,723,875 B2	8/2017	Liu		D887,632 S *	6/2020	Duque	D27/167
9,723,876 B2	8/2017	Cadieux et al.		D894,479 S *	8/2020	Cheung	D27/162
9,723,877 B2	8/2017	Wong et al.		D898,278 S *	10/2020	Carlberg	D27/162
9,730,471 B2	8/2017	Li et al.		2001/0015209 A1	8/2001	Zielke	
9,738,622 B2	8/2017	Dull et al.		2001/0032643 A1	10/2001	Hochrainer et al.	
D797,043 S	9/2017	Akana et al.		2001/0032795 A1	10/2001	Weinstein et al.	
D797,557 S	9/2017	Ziccardi		2001/0052480 A1	12/2001	Kawaguchi et al.	
D798,307 S	9/2017	Otsuka et al.		2002/0029779 A1	3/2002	Schmidt et al.	
9,763,478 B2	9/2017	Cameron et al.		2002/0043554 A1	4/2002	White et al.	
9,770,055 B2	9/2017	Cameron et al.		2002/0078951 A1	6/2002	Nichols et al.	
9,772,216 B2	9/2017	Poole et al.		2002/0088469 A1	7/2002	Rennecamp	
D799,110 S *	10/2017	Qiu	D27/101	2002/0142291 A1	10/2002	Bauer et al.	
D799,744 S *	10/2017	Qiu	D27/101	2002/0175164 A1	11/2002	Dees et al.	
D799,746 S	10/2017	Leidel et al.		2003/0004426 A1	1/2003	Melker et al.	
D800,132 S	10/2017	Maus et al.		2003/0005926 A1	1/2003	Jones et al.	
D800,379 S *	10/2017	Fang	D27/139	2003/0089377 A1	5/2003	Hajaligol et al.	
9,775,380 B2	10/2017	Fernando et al.		2003/0132219 A1	7/2003	Cox et al.	
9,802,011 B2	10/2017	Davidson et al.		2003/0149372 A1	8/2003	Smith et al.	
9,806,549 B2	10/2017	Liberti et al.		2003/0150451 A1	8/2003	Shayan	
D802,206 S	11/2017	Huang et al.		2003/0154991 A1	8/2003	Fournier et al.	
D802,838 S	11/2017	Clark et al.		2004/0031495 A1	2/2004	Steinberg	
D804,090 S	11/2017	Verleur et al.		2004/0050382 A1	3/2004	Goodchild	
9,809,567 B2	11/2017	Willis et al.		2004/0099266 A1	5/2004	Cross et al.	
9,814,263 B2	11/2017	Cochand et al.		2004/0129280 A1	7/2004	Woodson et al.	
9,814,272 B2	11/2017	Li et al.		2004/0149296 A1	8/2004	Rostami et al.	
9,820,508 B2	11/2017	Arnel et al.		2004/0149624 A1	8/2004	Wischusen et al.	
D804,306 S	12/2017	Simons et al.		2004/0173224 A1	9/2004	Burgard et al.	
D805,900 S	12/2017	Kapolas		2004/0173229 A1	9/2004	Crooks et al.	
D806,311 S	12/2017	Smith		2004/0182403 A1	9/2004	Andersson et al.	
D808,073 S	1/2018	Leidel		2004/0191322 A1	9/2004	Hansson	
D811,003 S	2/2018	Folyan		2004/0206350 A1	10/2004	Alston et al.	
9,889,983 B2	2/2018	Buse et al.		2004/0221857 A1	11/2004	Dominguez	
9,930,915 B2	4/2018	Worm et al.		2004/0226569 A1	11/2004	Yang et al.	
D819,881 S *	6/2018	Qiu	D27/101	2004/0237974 A1	12/2004	Min	
D822,271 S *	7/2018	Eksouzian	D27/101	2005/0016533 A1	1/2005	Schuler et al.	
D822,896 S *	7/2018	Durand	D27/101	2005/0016549 A1	1/2005	Banerjee et al.	
D824,093 S *	7/2018	Kauss	D27/101	2005/0016550 A1	1/2005	Katase	
D825,102 S *	8/2018	Bowen	D27/167	2005/0022806 A1	2/2005	Beaumont et al.	
D825,834 S *	8/2018	Chen	D27/101	2005/0029137 A1	2/2005	Wang	
D827,195 S *	8/2018	Chen	D27/101	2005/0034723 A1	2/2005	Bennett et al.	
10,076,139 B2 *	9/2018	Monsees	H05B 3/44	2005/0051453 A1	3/2005	Schuler et al.	
D829,980 S *	10/2018	Qiu	D27/162	2005/0056280 A1	3/2005	Alston et al.	
D832,499 S *	10/2018	Qiu	D27/162	2005/0061759 A1	3/2005	Doucette	
D832,500 S *	10/2018	Qiu	D27/162	2005/0069831 A1	3/2005	St. Charles et al.	
D834,246 S *	11/2018	Qiu	D27/162	2005/0081601 A1	4/2005	Lawson	
D836,831 S *	12/2018	Cividi	D27/162	2005/0090798 A1	4/2005	Clark et al.	
D837,446 S *	1/2019	Durand	D27/101	2005/0118545 A1	6/2005	Wong	
D843,644 S *	3/2019	Qiu	D27/101	2005/0134215 A1	6/2005	Bozzone et al.	
10,231,486 B2 *	3/2019	Bowen	A24F 42/60	2005/0145533 A1	7/2005	Seligson	
D855,876 S *	8/2019	Martin	D27/141	2005/0161467 A1	7/2005	Jones	
D856,575 S *	8/2019	Folkerts	D27/162	2005/0172976 A1	8/2005	Newman et al.	
D859,735 S *	9/2019	Qiu	D27/162	2005/0229918 A1	10/2005	Shim	
D860,519 S *	9/2019	Cividi	D27/162	2005/0236006 A1	10/2005	Cowan	
D860,520 S *	9/2019	Cividi	D27/162	2005/0244521 A1	11/2005	Strickland et al.	
D861,239 S *	9/2019	Chen	D27/101	2005/0268908 A1	12/2005	Bonney et al.	
10,405,582 B2 *	9/2019	Hatton	H05B 1/0244	2005/0268911 A1	12/2005	Cross et al.	
D861,973 S *	10/2019	Qiu	D27/101	2006/0016453 A1	1/2006	Kim	
D861,975 S *	10/2019	Bowen	D27/162	2006/0018840 A1	1/2006	Lechuga-Ballesteros et al.	
D863,665 S *	10/2019	Huang	D27/101	2006/0054676 A1	3/2006	Wischusen	
D863,670 S *	10/2019	He	D27/162	2006/0102175 A1	5/2006	Nelson	
D863,674 S *	10/2019	Chang	D27/162	2006/0150991 A1	7/2006	Lee	
D864,474 S *	10/2019	Smith	D27/162	2006/0185687 A1	8/2006	Hearn et al.	
D865,276 S *	10/2019	Pino	D27/162	2006/0191546 A1	8/2006	Takano et al.	
D866,852 S *	11/2019	Cividi	D27/101	2006/0191548 A1	8/2006	Strickland et al.	
D870,368 S *	12/2019	Leon Duque	D27/162	2006/0191594 A1	8/2006	Py	
D870,369 S *	12/2019	Greenbaum	D27/162	2006/0196518 A1	9/2006	Hon	
D870,370 S *	12/2019	Greenbaum	D27/162	2006/0254948 A1	11/2006	Herbert et al.	
D870,372 S *	12/2019	Zhu	D27/167	2006/0255105 A1	11/2006	Sweet	
				2007/0006889 A1	1/2007	Kobal et al.	
				2007/0045288 A1	3/2007	Nelson	
				2007/0045320 A1	3/2007	Biasecker et al.	
				2007/0062548 A1	3/2007	Horstmann et al.	



(56)

## References Cited

## U.S. PATENT DOCUMENTS

2007/0074734	A1	4/2007	Braunshteyn et al.	2010/0242976	A1	9/2010	Katayama et al.
2007/0089757	A1	4/2007	Bryman	2010/0275938	A1	11/2010	Roth et al.
2007/0098148	A1	5/2007	Sherman	2010/0276333	A1	11/2010	Couture
2007/0102013	A1	5/2007	Adams et al.	2010/0307116	A1	12/2010	Fisher
2007/0125765	A1	6/2007	Nelson	2010/0307518	A1	12/2010	Wang
2007/0144514	A1	6/2007	Yeates et al.	2010/0313901	A1	12/2010	Fernando et al.
2007/0163610	A1	7/2007	Lindell et al.	2011/0005535	A1	1/2011	Xiu
2007/0169773	A1	7/2007	Rock	2011/0011396	A1	1/2011	Fang
2007/0191756	A1	8/2007	Tapper	2011/0017741	A1	1/2011	Sprishen
2007/0215164	A1	9/2007	Mehio	2011/0030706	A1	2/2011	Gibson et al.
2007/0215168	A1	9/2007	Banerjee et al.	2011/0036346	A1	2/2011	Cohen et al.
2007/0229025	A1	10/2007	Tsai et al.	2011/0036363	A1	2/2011	Urtsev et al.
2007/0235046	A1	10/2007	Gedevanishvili	2011/0041861	A1	2/2011	Sebastian et al.
2007/0267033	A1	11/2007	Mishra et al.	2011/0049226	A1	3/2011	Moreau et al.
2007/0277816	A1	12/2007	Morrison et al.	2011/0083684	A1	4/2011	Luan et al.
2007/0280652	A1	12/2007	Williams	2011/0094523	A1	4/2011	Thorens et al.
2007/0283972	A1	12/2007	Monsees et al.	2011/0097060	A1	4/2011	Buzzetti
2007/0295347	A1	12/2007	Paine et al.	2011/0105096	A1	5/2011	Dods et al.
2008/0000763	A1	1/2008	Cove	2011/0108023	A1	5/2011	McKinney et al.
2008/0023003	A1	1/2008	Rosenthal	2011/0120482	A1	5/2011	Brenneise
2008/0029095	A1	2/2008	Esser	2011/0126831	A1	6/2011	Pernia
2008/0065176	A1	3/2008	Zhang et al.	2011/0155151	A1	6/2011	Newman et al.
2008/0092912	A1	4/2008	Robinson et al.	2011/0155153	A1	6/2011	Thorens et al.
2008/0138423	A1	6/2008	Gonda	2011/0162667	A1	7/2011	Burke et al.
2008/0149118	A1	6/2008	Oglesby et al.	2011/0168194	A1	7/2011	Hon
2008/0207276	A1	8/2008	Burrell	2011/0180433	A1	7/2011	Rennecamp
2008/0214103	A1	9/2008	Nelson et al.	2011/0192397	A1	8/2011	Saskar et al.
2008/0216828	A1	9/2008	Wensley et al.	2011/0226236	A1	9/2011	Buchberger
2008/0241255	A1	10/2008	Rose et al.	2011/0226266	A1	9/2011	Tao
2008/0257367	A1	10/2008	Paterno et al.	2011/0232654	A1	9/2011	Mass
2008/0276947	A1	11/2008	Martzel	2011/0232655	A1	9/2011	Chan et al.
2008/0286340	A1	11/2008	Andersson et al.	2011/0236002	A1	9/2011	Oglesby et al.
2008/0302375	A1	12/2008	Andersson et al.	2011/0240047	A1	10/2011	Adamic
2009/0004249	A1	1/2009	Gonda	2011/0263947	A1	10/2011	Utley et al.
2009/0071469	A1	3/2009	Abrams	2011/0265788	A1	11/2011	Wu
2009/0095287	A1	4/2009	Emarlou	2011/0265806	A1	11/2011	Alarcon et al.
2009/0095311	A1	4/2009	Han	2011/0268809	A1	11/2011	Brinkley et al.
2009/0111287	A1	4/2009	Lindberg et al.	2011/0277780	A1	11/2011	Terry et al.
2009/0126745	A1	5/2009	Hon	2011/0278189	A1	11/2011	Terry et al.
2009/0133691	A1	5/2009	Yamada et al.	2011/0284520	A1	11/2011	Fong
2009/0133703	A1	5/2009	Strickland et al.	2011/0290248	A1	12/2011	Schennum
2009/0133704	A1	5/2009	Strickland et al.	2011/0290269	A1	12/2011	Shimizu
2009/0141196	A1	6/2009	Basner et al.	2011/0293535	A1	12/2011	Kosik et al.
2009/0151717	A1	6/2009	Bowen et al.	2011/0308515	A1	12/2011	Snyder et al.
2009/0188490	A1	7/2009	Han	2011/0308521	A1	12/2011	Kofford
2009/0192443	A1	7/2009	Collins, Jr.	2011/0315152	A1	12/2011	Hearn et al.
2009/0230117	A1	9/2009	Fernando et al.	2011/0315701	A1	12/2011	Everson
2009/0239581	A1	9/2009	Lee	2012/0006342	A1	1/2012	Rose et al.
2009/0255534	A1	10/2009	Paterno	2012/0060853	A1	3/2012	Robinson et al.
2009/0260641	A1	10/2009	Monsees et al.	2012/0077849	A1	3/2012	Howson et al.
2009/0260642	A1	10/2009	Monsees et al.	2012/0086391	A1	4/2012	Smith
2009/0267252	A1	10/2009	Ikeyama	2012/0111346	A1	5/2012	Rinker et al.
2009/0272379	A1	11/2009	Thorens et al.	2012/0111347	A1	5/2012	Hon
2009/0283103	A1	11/2009	Nielsen et al.	2012/0118301	A1	5/2012	Montaser
2009/0288668	A1	11/2009	Inagaki	2012/0118307	A1	5/2012	Tu
2009/0288669	A1	11/2009	Hutchens	2012/0125353	A1	5/2012	Wollin
2009/0293892	A1	12/2009	Williams et al.	2012/0138052	A1	6/2012	Hearn et al.
2009/0293895	A1	12/2009	Axelsson et al.	2012/0174914	A1	7/2012	Pirshafiey et al.
2009/0302019	A1	12/2009	Selenski et al.	2012/0188687	A1	7/2012	Yamamoto
2009/0308387	A1	12/2009	Andersen et al.	2012/0199146	A1	8/2012	Marangos
2009/0314299	A1	12/2009	Kilpatrick	2012/0199572	A1	8/2012	Shen et al.
2010/0000672	A1	1/2010	Fogle	2012/0199663	A1	8/2012	Qiu
2010/0006092	A1	1/2010	Hale et al.	2012/0204889	A1	8/2012	Xiu
2010/0024834	A1	2/2010	Oglesby et al.	2012/0211015	A1	8/2012	Li et al.
2010/0031968	A1	2/2010	Sheikh et al.	2012/0227753	A1	9/2012	Newton
2010/0059073	A1	3/2010	Hoffmann et al.	2012/0234315	A1	9/2012	Li et al.
2010/0156193	A1	6/2010	Rhodes et al.	2012/0234821	A1	9/2012	Shimizu
2010/0163063	A1	7/2010	Fernando et al.	2012/0247494	A1	10/2012	Oglesby et al.
2010/0163065	A1	7/2010	Chang	2012/0255567	A1	10/2012	Rose et al.
2010/0186757	A1	7/2010	Crooks et al.	2012/0260926	A1	10/2012	Tu et al.
2010/0200006	A1	8/2010	Robinson et al.	2012/0260927	A1	10/2012	Liu
2010/0200008	A1	8/2010	Taieb	2012/0261286	A1	10/2012	Holloway et al.
2010/0236562	A1	9/2010	Hearn et al.	2012/0267383	A1	10/2012	Van Rooyen
2010/0242956	A1	9/2010	Yamada et al.	2012/0279512	A1	11/2012	Hon
2010/0242974	A1	9/2010	Pan	2012/0285475	A1	11/2012	Liu
				2012/0291791	A1	11/2012	Pradeep
				2012/0298676	A1	11/2012	Cooks
				2012/0312313	A1	12/2012	Frija
				2012/0318882	A1	12/2012	Abehasera



(56)

## References Cited

## U.S. PATENT DOCUMENTS

2012/0325227	A1	12/2012	Robinson et al.	2014/0035391	A1	2/2014	Kitani
2012/0325228	A1	12/2012	Williams	2014/0041655	A1	2/2014	Barron et al.
2013/0001185	A1	1/2013	Antier et al.	2014/0041658	A1	2/2014	Goodman et al.
2013/0008457	A1	1/2013	Zheng et al.	2014/0048086	A1	2/2014	Zhanghua
2013/0014755	A1	1/2013	Kumar et al.	2014/0053856	A1	2/2014	Liu
2013/0014772	A1	1/2013	Liu	2014/0053858	A1	2/2014	Liu
2013/0019887	A1	1/2013	Liu	2014/0060528	A1	3/2014	Liu
2013/0023850	A1	1/2013	Imran et al.	2014/0060529	A1	3/2014	Zhang
2013/0025609	A1	1/2013	Liu	2014/0060552	A1	3/2014	Cohen
2013/0037041	A1	2/2013	Worm et al.	2014/0060556	A1	3/2014	Liu
2013/0042864	A1	2/2013	Adler et al.	2014/0062417	A1	3/2014	Li et al.
2013/0042865	A1	2/2013	Monsees et al.	2014/0069424	A1	3/2014	Poston et al.
2013/0047984	A1	2/2013	Dahne et al.	2014/0069425	A1	3/2014	Zhang
2013/0056012	A1	3/2013	Hearn et al.	2014/0083442	A1	3/2014	Scatterday
2013/0056013	A1	3/2013	Terry et al.	2014/0096781	A1	4/2014	Sears et al.
2013/0068239	A1	3/2013	Youn	2014/0096782	A1	4/2014	Ampolini et al.
2013/0074857	A1	3/2013	Buchberger	2014/0107815	A1	4/2014	Lamothe
2013/0081642	A1	4/2013	Safari	2014/0109898	A1	4/2014	Li et al.
2013/0087160	A1	4/2013	Gherghe	2014/0109921	A1	4/2014	Chen
2013/0099025	A1	4/2013	McDonnell	2014/0116455	A1	5/2014	Youn
2013/0133675	A1	5/2013	Shinozaki et al.	2014/0123989	A1	5/2014	LaMothe
2013/0140200	A1	6/2013	Scatterday	2014/0123990	A1	5/2014	Timmermans
2013/0146489	A1	6/2013	Scatterday	2014/0130796	A1	5/2014	Liu
2013/0152922	A1	6/2013	Benassayag et al.	2014/0130797	A1	5/2014	Liu
2013/0152954	A1	6/2013	Youn	2014/0130816	A1	5/2014	Liu
2013/0167854	A1	7/2013	Shin	2014/0130817	A1	5/2014	Li et al.
2013/0168880	A1	7/2013	Duke	2014/0144429	A1	5/2014	Wensley et al.
2013/0174842	A1	7/2013	Young et al.	2014/0144453	A1	5/2014	Capuano et al.
2013/0182421	A1	7/2013	Popper et al.	2014/0150784	A1	6/2014	Liu
2013/0186416	A1	7/2013	Gao et al.	2014/0150785	A1	6/2014	Malik et al.
2013/0192615	A1	8/2013	Tucker et al.	2014/0150810	A1	6/2014	Hon
2013/0192618	A1	8/2013	Li et al.	2014/0158129	A1	6/2014	Pratt, Jr. et al.
2013/0192619	A1	8/2013	Tucker et al.	2014/0158660	A1	6/2014	Wood et al.
2013/0199528	A1	8/2013	Goodman et al.	2014/0161301	A1	6/2014	Merenda
2013/0213417	A1	8/2013	Chong et al.	2014/0166028	A1	6/2014	Fuisz et al.
2013/0213418	A1	8/2013	Tucker et al.	2014/0166029	A1	6/2014	Weigensberg et al.
2013/0213419	A1	8/2013	Tucker et al.	2014/0166030	A1	6/2014	Li et al.
2013/0220315	A1	8/2013	Conley et al.	2014/0166032	A1	6/2014	Gindrat
2013/0220847	A1	8/2013	Fisher et al.	2014/0174458	A1	6/2014	Katz
2013/0228190	A1	9/2013	Weiss et al.	2014/0174459	A1	6/2014	Burstyn
2013/0228191	A1	9/2013	Newton	2014/0175081	A1	6/2014	Hwa
2013/0233086	A1	9/2013	Besling et al.	2014/0178461	A1	6/2014	Rigas
2013/0247924	A1	9/2013	Scatterday et al.	2014/0182609	A1	7/2014	Liu
2013/0248385	A1	9/2013	Scatterday et al.	2014/0182610	A1	7/2014	Liu
2013/0255702	A1	10/2013	Griffith, Jr. et al.	2014/0182611	A1	7/2014	Liu
2013/0263869	A1	10/2013	Zhu	2014/0182612	A1	7/2014	Chen
2013/0276802	A1	10/2013	Scatterday	2014/0190477	A1	7/2014	Qiu
2013/0284190	A1	10/2013	Scatterday et al.	2014/0190478	A1	7/2014	Liu
2013/0284191	A1	10/2013	Scatterday et al.	2014/0190496	A1	7/2014	Wensley et al.
2013/0284192	A1	10/2013	Peleg et al.	2014/0190501	A1	7/2014	Liu
2013/0298905	A1	11/2013	Levin et al.	2014/0190502	A1	7/2014	Liu
2013/0306065	A1	11/2013	Thorens et al.	2014/0190503	A1	7/2014	Li et al.
2013/0306084	A1	11/2013	Flick	2014/0196716	A1	7/2014	Liu
2013/0312742	A1	11/2013	Monsees et al.	2014/0196718	A1	7/2014	Li et al.
2013/0319431	A1	12/2013	Cyphert et al.	2014/0196731	A1	7/2014	Scatterday
2013/0319435	A1	12/2013	Flick	2014/0196733	A1	7/2014	Liu
2013/0319436	A1	12/2013	Liu	2014/0196734	A1	7/2014	Liu
2013/0319437	A1	12/2013	Liu	2014/0196735	A1	7/2014	Liu
2013/0319438	A1	12/2013	Liu	2014/0202454	A1	7/2014	Buchberger
2013/0319439	A1	12/2013	Gorelick et al.	2014/0202474	A1	7/2014	Peleg et al.
2013/0319440	A1	12/2013	Capuano	2014/0202475	A1	7/2014	Liu
2013/0323941	A1	12/2013	Zeliff et al.	2014/0202477	A1	7/2014	Qi et al.
2013/0333700	A1	12/2013	Buchberger	2014/0209096	A1	7/2014	Cheyene
2013/0333711	A1	12/2013	Liu	2014/0209106	A1	7/2014	Liu
2013/0336358	A1	12/2013	Liu	2014/0209107	A1	7/2014	Liu
2013/0340775	A1	12/2013	Juster et al.	2014/0209108	A1	7/2014	Li et al.
2013/0342157	A1	12/2013	Liu	2014/0209109	A1	7/2014	Larson
2014/0000638	A1	1/2014	Sebastian et al.	2014/0216450	A1	8/2014	Liu
2014/0007891	A1	1/2014	Liu	2014/0216483	A1	8/2014	Alima
2014/0007892	A1	1/2014	Liu	2014/0216484	A1	8/2014	Liu
2014/0014124	A1	1/2014	Glasberg et al.	2014/0224244	A1	8/2014	Liu
2014/0014126	A1	1/2014	Peleg et al.	2014/0224267	A1	8/2014	Levitz et al.
2014/0020697	A1	1/2014	Liu	2014/0230835	A1	8/2014	Saliman
2014/0034052	A1	2/2014	Glusker et al.	2014/0238421	A1	8/2014	Shapiro
2014/0034071	A1	2/2014	Levitz et al.	2014/0238422	A1	8/2014	Plunkett et al.
				2014/0238423	A1	8/2014	Tucker et al.
				2014/0238424	A1	8/2014	Macko et al.
				2014/0246031	A1	9/2014	Liu
				2014/0246033	A1	9/2014	Daehne et al.



(56)

## References Cited

## U.S. PATENT DOCUMENTS

2014/0251324	A1	9/2014	Xiang	2014/0354215	A1	12/2014	Xiang
2014/0251325	A1	9/2014	Liu	2014/0355969	A1	12/2014	Stern
2014/0251356	A1	9/2014	Xiang	2014/0356607	A1	12/2014	Woodcock
2014/0253144	A1	9/2014	Novak, III et al.	2014/0360512	A1	12/2014	Xiang
2014/0254055	A1	9/2014	Xiang	2014/0360516	A1	12/2014	Liu
2014/0259026	A1	9/2014	Xiang	2014/0366894	A1	12/2014	Liu
2014/0261408	A1	9/2014	DePiano et al.	2014/0366895	A1	12/2014	Li et al.
2014/0261474	A1	9/2014	Gonda	2014/0366896	A1	12/2014	Li et al.
2014/0261479	A1	9/2014	Xu et al.	2014/0366897	A1	12/2014	Liu
2014/0261483	A1	9/2014	Hopps	2014/0366898	A1	12/2014	Monsees et al.
2014/0261486	A1	9/2014	Potter et al.	2014/0366902	A1	12/2014	Chiolini et al.
2014/0261487	A1	9/2014	Chapman et al.	2014/0373833	A1	12/2014	Liu
2014/0261488	A1	9/2014	Tucker	2014/0373855	A1	12/2014	Zheng
2014/0261489	A1	9/2014	Cadieux et al.	2014/0373858	A1	12/2014	Liu
2014/0261490	A1	9/2014	Kane	2014/0376895	A1	12/2014	Han
2014/0261491	A1	9/2014	Hawes	2014/0378790	A1	12/2014	Cohen
2014/0261492	A1	9/2014	Kane et al.	2015/0000682	A1	1/2015	Liu
2014/0261493	A1	9/2014	Smith et al.	2015/0000683	A1	1/2015	Liu
2014/0261494	A1	9/2014	Scatterday	2015/0007834	A1	1/2015	Liu
2014/0261495	A1	9/2014	Novak, III et al.	2015/0007835	A1	1/2015	Liu
2014/0261497	A1	9/2014	Liu	2015/0007836	A1	1/2015	Li et al.
2014/0261498	A1	9/2014	Liu	2015/0013692	A1	1/2015	Liu
2014/0261500	A1	9/2014	Park	2015/0013693	A1	1/2015	Fuisz et al.
2014/0270727	A1	9/2014	Ampolini et al.	2015/0013696	A1	1/2015	Plojoux et al.
2014/0270729	A1	9/2014	DePiano et al.	2015/0013700	A1	1/2015	Liu
2014/0270730	A1	9/2014	DePiano et al.	2015/0013701	A1	1/2015	Liu
2014/0271946	A1	9/2014	Kobal et al.	2015/0013702	A1	1/2015	Liu
2014/0274940	A1	9/2014	Mishra et al.	2015/0015187	A1	1/2015	Xiang
2014/0276536	A1	9/2014	Estes	2015/0020822	A1	1/2015	Janardhan et al.
2014/0278250	A1	9/2014	Smith et al.	2015/0020823	A1	1/2015	Lipowicz et al.
2014/0278258	A1	9/2014	Shafer	2015/0020824	A1	1/2015	Bowen et al.
2014/0283823	A1	9/2014	Liu	2015/0020825	A1	1/2015	Galloway et al.
2014/0283855	A1	9/2014	Hawes et al.	2015/0020826	A1	1/2015	Liu
2014/0283856	A1	9/2014	Xiang	2015/0020827	A1	1/2015	Liu
2014/0283857	A1	9/2014	Liu	2015/0020828	A1	1/2015	Liu
2014/0283858	A1	9/2014	Liu	2015/0020829	A1	1/2015	Li
2014/0290673	A1	10/2014	Liu	2015/0020830	A1	1/2015	Koller
2014/0290676	A1	10/2014	Liu	2015/0020831	A1	1/2015	Weigensberg et al.
2014/0290677	A1	10/2014	Liu	2015/0020833	A1	1/2015	Conley et al.
2014/0299137	A1	10/2014	Kieckbusch et al.	2015/0027454	A1	1/2015	Li et al.
2014/0299138	A1	10/2014	Xiang	2015/0027455	A1	1/2015	Peleg et al.
2014/0299139	A1	10/2014	Liu	2015/0027456	A1	1/2015	Janardhan et al.
2014/0299140	A1	10/2014	Liu	2015/0027457	A1	1/2015	Janardhan et al.
2014/0301721	A1	10/2014	Ruscio et al.	2015/0027460	A1	1/2015	Liu
2014/0305450	A1	10/2014	Xiang	2015/0027461	A1	1/2015	Liu
2014/0305451	A1	10/2014	Liu	2015/0027462	A1	1/2015	Liu
2014/0305452	A1	10/2014	Liu	2015/0027463	A1	1/2015	Liu
2014/0305454	A1	10/2014	Rinker et al.	2015/0027464	A1	1/2015	Liu
2014/0311503	A1	10/2014	Liu	2015/0027465	A1	1/2015	Liu
2014/0311504	A1	10/2014	Liu	2015/0027466	A1	1/2015	Xiang
2014/0311505	A1	10/2014	Liu	2015/0027467	A1	1/2015	Liu
2014/0321837	A1	10/2014	Flick	2015/0027468	A1	1/2015	Li et al.
2014/0332016	A1	11/2014	Bellinger et al.	2015/0027469	A1	1/2015	Tucker et al.
2014/0332017	A1	11/2014	Liu	2015/0027470	A1	1/2015	Kane et al.
2014/0332018	A1	11/2014	Liu	2015/0027471	A1	1/2015	Feldman et al.
2014/0332019	A1	11/2014	Liu	2015/0027472	A1	1/2015	Amir
2014/0332020	A1	11/2014	Li et al.	2015/0027473	A1	1/2015	Graf
2014/0332022	A1	11/2014	Li et al.	2015/0034102	A1	2/2015	Faramarzian
2014/0334803	A1	11/2014	Li et al.	2015/0034103	A1	2/2015	Hon
2014/0334804	A1	11/2014	Choi	2015/0034104	A1	2/2015	Zhou
2014/0338680	A1	11/2014	Abramov et al.	2015/0034105	A1	2/2015	Liu
2014/0338681	A1	11/2014	Liu	2015/0034106	A1	2/2015	Liu
2014/0338682	A1	11/2014	Liu	2015/0034107	A1	2/2015	Liu
2014/0338683	A1	11/2014	Liu	2015/0034507	A1	2/2015	Liu
2014/0338684	A1	11/2014	Liu	2015/0035540	A1	2/2015	Xiang
2014/0338685	A1	11/2014	Amir	2015/0038567	A1	2/2015	Herkenroth et al.
2014/0345631	A1	11/2014	Bowen et al.	2015/0040927	A1	2/2015	Li et al.
2014/0345632	A1	11/2014	Scatterday	2015/0040928	A1	2/2015	Saydar et al.
2014/0345633	A1	11/2014	Talon et al.	2015/0040929	A1	2/2015	Hon
2014/0345635	A1	11/2014	Rabinowitz et al.	2015/0041482	A1	2/2015	Liu
2014/0352177	A1	12/2014	Rehkemper	2015/0047658	A1	2/2015	Cyphert et al.
2014/0352705	A1	12/2014	Liu	2015/0047659	A1	2/2015	Liu
2014/0352707	A1	12/2014	Liu	2015/0047660	A1	2/2015	Liu
2014/0353856	A1	12/2014	Dubief	2015/0047661	A1	2/2015	Blackley et al.
2014/0353867	A1	12/2014	Liu	2015/0047662	A1	2/2015	Hopps
				2015/0047663	A1	2/2015	Liu
				2015/0053215	A1	2/2015	Liu
				2015/0053216	A1	2/2015	Liu
				2015/0053217	A1	2/2015	Steingraber et al.



(56)

## References Cited

## U.S. PATENT DOCUMENTS

2015/0053220	A1	2/2015	Levy et al.	2015/0157055	A1	6/2015	Lord
2015/0057341	A1	2/2015	Perry	2015/0157056	A1	6/2015	Bowen et al.
2015/0059779	A1	3/2015	Alarcon et al.	2015/0163859	A1	6/2015	Schneider et al.
2015/0059780	A1	3/2015	Davis et al.	2015/0164138	A1	6/2015	Liu
2015/0059782	A1	3/2015	Liu	2015/0164141	A1	6/2015	Newton
2015/0059783	A1	3/2015	Liu	2015/0164142	A1	6/2015	Li et al.
2015/0059784	A1	3/2015	Liu	2015/0164143	A1	6/2015	Maas
2015/0059785	A1	3/2015	Liu	2015/0164144	A1	6/2015	Liu
2015/0068523	A1	3/2015	Powers et al.	2015/0164145	A1	6/2015	Zhou
2015/0068543	A1	3/2015	Liu	2015/0164146	A1	6/2015	Li et al.
2015/0068545	A1	3/2015	Moldoveanu et al.	2015/0164147	A1	6/2015	Verleur et al.
2015/0075545	A1	3/2015	Xiang	2015/0167976	A1	6/2015	Recio
2015/0075546	A1	3/2015	Kueny, Sr. et al.	2015/0173124	A1	6/2015	Qiu
2015/0078735	A1	3/2015	Cormack	2015/0173417	A1	6/2015	Gennrich et al.
2015/0080265	A1	3/2015	Elzinga et al.	2015/0173419	A1	6/2015	Tu
2015/0082859	A1	3/2015	Xiang	2015/0173421	A1	6/2015	Hsieh
2015/0083144	A1	3/2015	Xiang	2015/0173422	A1	6/2015	Liu
2015/0083145	A1	3/2015	Li et al.	2015/0181928	A1	7/2015	Liu
2015/0083146	A1	3/2015	Goldman et al.	2015/0181937	A1	7/2015	Dubief et al.
2015/0083147	A1	3/2015	Schiff et al.	2015/0181939	A1	7/2015	Liu
2015/0090256	A1	4/2015	Chung	2015/0181940	A1	7/2015	Liu
2015/0090277	A1	4/2015	Xiang	2015/0181941	A1	7/2015	Liu
2015/0090278	A1	4/2015	Schiff et al.	2015/0181943	A1	7/2015	Li et al.
2015/0090279	A1	4/2015	Chen	2015/0181944	A1	7/2015	Li et al.
2015/0090280	A1	4/2015	Chen	2015/0184846	A1	7/2015	Liu
2015/0090281	A1	4/2015	Chen	2015/0186837	A1	7/2015	Bianco et al.
2015/0100441	A1	4/2015	Alarcon et al.	2015/0189695	A1	7/2015	Xiang
2015/0101606	A1	4/2015	White	2015/0189915	A1	7/2015	Liu
2015/0101622	A1	4/2015	Liu	2015/0189918	A1	7/2015	Liu
2015/0101623	A1	4/2015	Liu	2015/0189919	A1	7/2015	Liu
2015/0101625	A1	4/2015	Newton et al.	2015/0189920	A1	7/2015	Liu
2015/0101626	A1	4/2015	Li et al.	2015/0196055	A1	7/2015	Liu
2015/0101945	A1	4/2015	Scatterday	2015/0196056	A1	7/2015	Liu
2015/0102777	A1	4/2015	Cooper	2015/0196057	A1	7/2015	Wu
2015/0105455	A1	4/2015	Bjorncrantz	2015/0196058	A1	7/2015	Lord
2015/0107609	A1	4/2015	Liu	2015/0196059	A1	7/2015	Liu
2015/0107610	A1	4/2015	Metrangolo et al.	2015/0196060	A1	7/2015	Wensley et al.
2015/0107611	A1	4/2015	Metrangolo et al.	2015/0196062	A1	7/2015	Li et al.
2015/0107612	A1	4/2015	Liu	2015/0200385	A1	7/2015	Liu
2015/0108019	A1	4/2015	Liu	2015/0201674	A1	7/2015	Dooly et al.
2015/0114407	A1	4/2015	Duncan et al.	2015/0201675	A1	7/2015	Lord
2015/0114410	A1	4/2015	Doster	2015/0201676	A1	7/2015	Shin
2015/0114504	A1	4/2015	Cecka et al.	2015/0208724	A1	7/2015	Wu
2015/0117842	A1	4/2015	Brammer et al.	2015/0208725	A1	7/2015	Tsai
2015/0122252	A1	5/2015	Frija	2015/0208726	A1	7/2015	Liu
2015/0122274	A1	5/2015	Cohen et al.	2015/0208728	A1	7/2015	Lord
2015/0122278	A1	5/2015	Hardgrove et al.	2015/0208729	A1	7/2015	Monsees et al.
2015/0128965	A1	5/2015	Lord	2015/0208730	A1	7/2015	Li et al.
2015/0128966	A1	5/2015	Lord	2015/0208731	A1	7/2015	Malamud et al.
2015/0128967	A1	5/2015	Robinson et al.	2015/0216232	A1	8/2015	Bless et al.
2015/0128969	A1	5/2015	Chapman et al.	2015/0216233	A1	8/2015	Sears et al.
2015/0128970	A1	5/2015	Liu	2015/0216234	A1	8/2015	Chung
2015/0128971	A1	5/2015	Verleur et al.	2015/0216235	A1	8/2015	Liu
2015/0128972	A1	5/2015	Verleur et al.	2015/0216237	A1	8/2015	Wensley et al.
2015/0128973	A1	5/2015	Li et al.	2015/0217067	A1	8/2015	Hearn et al.
2015/0128976	A1	5/2015	Verleur et al.	2015/0217068	A1	8/2015	Wakalopulos
2015/0128977	A1	5/2015	Li et al.	2015/0223520	A1	8/2015	Phillips et al.
2015/0136153	A1	5/2015	Lord	2015/0223521	A1	8/2015	Menting et al.
2015/0136154	A1	5/2015	Mitrev et al.	2015/0223522	A1	8/2015	Ampolini et al.
2015/0136155	A1	5/2015	Verleur et al.	2015/0223523	A1	8/2015	McCullough
2015/0136156	A1	5/2015	Liu	2015/0224268	A1	8/2015	Henry et al.
2015/0136157	A1	5/2015	Liu	2015/0227471	A1	8/2015	Stafford et al.
2015/0136158	A1	5/2015	Stevens et al.	2015/0230521	A1	8/2015	Talon
2015/0142387	A1	5/2015	Alarcon et al.	2015/0237914	A1	8/2015	Han
2015/0144145	A1	5/2015	Chang et al.	2015/0237916	A1	8/2015	Farine et al.
2015/0144147	A1	5/2015	Li et al.	2015/0237917	A1	8/2015	Lord
2015/0144148	A1	5/2015	Chen	2015/0237918	A1	8/2015	Liu
2015/0150302	A1	6/2015	Metrangolo et al.	2015/0238723	A1	8/2015	Knudsen
2015/0150303	A1	6/2015	Jensen	2015/0245654	A1	9/2015	Memari et al.
2015/0150305	A1	6/2015	Shenkai	2015/0245655	A1	9/2015	Memari et al.
2015/0150306	A1	6/2015	Chen	2015/0245657	A1	9/2015	Memari et al.
2015/0150307	A1	6/2015	Liu	2015/0245658	A1	9/2015	Worm et al.
2015/0150308	A1	6/2015	Monsees et al.	2015/0245659	A1	9/2015	DePiano et al.
2015/0157053	A1	6/2015	Mayor	2015/0245660	A1	9/2015	Lord
2015/0157054	A1	6/2015	Liu	2015/0245661	A1	9/2015	Milin
				2015/0245665	A1	9/2015	Memari et al.
				2015/0245666	A1	9/2015	Memari et al.
				2015/0245667	A1	9/2015	Memari et al.
				2015/0245668	A1	9/2015	Memari et al.



(56)

## References Cited

## U.S. PATENT DOCUMENTS

2015/0245669	A1	9/2015	Cadieux et al.	2015/0342259	A1	12/2015	Baker et al.
2015/0257441	A1	9/2015	Gerkin	2015/0351449	A1	12/2015	Righetti
2015/0257444	A1	9/2015	Chung	2015/0351454	A1	12/2015	Huang
2015/0257445	A1	9/2015	Henry, Jr. et al.	2015/0351455	A1	12/2015	Liu
2015/0257446	A1	9/2015	Chung	2015/0351456	A1	12/2015	Johnson et al.
2015/0257447	A1	9/2015	Sullivan	2015/0351457	A1	12/2015	Liu
2015/0257449	A1	9/2015	Gabbay	2015/0357608	A1	12/2015	Huang
2015/0257451	A1	9/2015	Brannon et al.	2015/0357839	A1	12/2015	Cai et al.
2015/0258289	A1	9/2015	Henry, Jr. et al.	2015/0359258	A1	12/2015	Mishra et al.
2015/0272211	A1	10/2015	Chung	2015/0359261	A1	12/2015	Li et al.
2015/0272215	A1	10/2015	Esses	2015/0359262	A1	12/2015	Liu et al.
2015/0272217	A1	10/2015	Chen	2015/0359263	A1	12/2015	Bellinger
2015/0272218	A1	10/2015	Chen	2015/0359264	A1	12/2015	Fernando et al.
2015/0272220	A1	10/2015	Spinka et al.	2015/0359265	A1	12/2015	Liu
2015/0272221	A1	10/2015	Liu	2015/0366250	A1	12/2015	Landau
2015/0272222	A1	10/2015	Spinka et al.	2015/0366265	A1	12/2015	Lansing
2015/0272223	A1	10/2015	Weigensberg et al.	2015/0366266	A1	12/2015	Chen
2015/0276262	A1	10/2015	Dai et al.	2015/0366267	A1	12/2015	Liu
2015/0280273	A1	10/2015	Liu	2015/0366268	A1	12/2015	Shabat
2015/0282524	A1	10/2015	Elhalwani	2015/0374035	A1	12/2015	Sanchez et al.
2015/0282525	A1	10/2015	Plojoux et al.	2015/0374039	A1	12/2015	Zhu
2015/0282526	A1	10/2015	Wu	2015/0374040	A1	12/2015	Chen
2015/0282527	A1	10/2015	Henry, Jr.	2016/0000147	A1	1/2016	Li et al.
2015/0282529	A1	10/2015	Li et al.	2016/0000148	A1	1/2016	Liu
2015/0282530	A1	10/2015	Johnson et al.	2016/0000149	A1	1/2016	Scatterday
2015/0288468	A1	10/2015	Xiang	2016/0002649	A1	1/2016	Kudithipudi et al.
2015/0289565	A1	10/2015	Cadieux et al.	2016/0007650	A1	1/2016	Duncan et al.
2015/0289567	A1	10/2015	Liu	2016/0007651	A1	1/2016	Ampolini et al.
2015/0295921	A1	10/2015	Cao	2016/0007653	A1	1/2016	Tu
2015/0296883	A1	10/2015	Wu	2016/0007654	A1	1/2016	Zhu
2015/0296885	A1	10/2015	Liu	2016/0007655	A1	1/2016	Li et al.
2015/0296886	A1	10/2015	Li et al.	2016/0010103	A1	1/2016	Kudithipudi et al.
2015/0296887	A1	10/2015	Zhu	2016/0015082	A1	1/2016	Liu
2015/0296888	A1	10/2015	Liu	2016/0018347	A1	1/2016	Drbal et al.
2015/0296889	A1	10/2015	Liu	2016/0020048	A1	1/2016	Ware
2015/0304401	A1	10/2015	Liu	2016/0021771	A1	1/2016	Zhang et al.
2015/0304402	A1	10/2015	Liu	2016/0021930	A1	1/2016	Minskoff et al.
2015/0305403	A1	10/2015	Coelho Belo Fernandes De Carvalho	2016/0021931	A1	1/2016	Hawes et al.
2015/0305404	A1	10/2015	Rosales	2016/0021932	A1	1/2016	Silvestrini et al.
2015/0305406	A1	10/2015	Li et al.	2016/0021933	A1	1/2016	Thorens et al.
2015/0305407	A1	10/2015	Li et al.	2016/0021934	A1	1/2016	Cadieux et al.
2015/0305408	A1	10/2015	Liu	2016/0029225	A1	1/2016	Hu
2015/0305409	A1	10/2015	Verleur et al.	2016/0029694	A1	2/2016	Clements et al.
2015/0305464	A1	10/2015	Nelson, Jr. et al.	2016/0029697	A1	2/2016	Shafer
2015/0313275	A1	11/2015	Anderson et al.	2016/0029698	A1	2/2016	Xiang
2015/0313282	A1	11/2015	Ademe et al.	2016/0029699	A1	2/2016	Li et al.
2015/0313283	A1	11/2015	Collett et al.	2016/0029700	A1	2/2016	Li et al.
2015/0313284	A1	11/2015	Liu	2016/0037826	A1	2/2016	Hearn et al.
2015/0313285	A1	11/2015	Waller et al.	2016/0044961	A1	2/2016	Liu
2015/0313287	A1	11/2015	Verleur et al.	2016/0044964	A1	2/2016	Liu
2015/0313288	A1	11/2015	Liu	2016/0044965	A1	2/2016	Liu
2015/0313868	A1	11/2015	Morgan	2016/0044966	A1	2/2016	Li et al.
2015/0320114	A1	11/2015	Wu	2016/0044967	A1	2/2016	Bowen et al.
2015/0320116	A1	11/2015	Bleloch et al.	2016/0044968	A1	2/2016	Bowen et al.
2015/0321804	A1	11/2015	Koller et al.	2016/0049682	A1	2/2016	Won et al.
2015/0322451	A1	11/2015	Kudithipudi et al.	2016/0051716	A1	2/2016	Wheelock
2015/0327595	A1	11/2015	Scatterday	2016/0053988	A1	2/2016	Quintana
2015/0327596	A1	11/2015	Alarcon et al.	2016/0057811	A1	2/2016	Alarcon et al.
2015/0327597	A1	11/2015	Li et al.	2016/0058066	A1	3/2016	Banks et al.
2015/0327598	A1	11/2015	Xiang	2016/0058071	A1	3/2016	Hearn
2015/0328415	A1	11/2015	Minskoff et al.	2016/0058072	A1	3/2016	Liu
2015/0332379	A1	11/2015	Alarcon	2016/0058073	A1	3/2016	Chen
2015/0333542	A1	11/2015	Alarcon et al.	2016/0058074	A1	3/2016	Liu
2015/0333552	A1	11/2015	Alarcon	2016/0066617	A1	3/2016	Yilmaz et al.
2015/0333561	A1	11/2015	Alarcon	2016/0073677	A1	3/2016	Kappel et al.
2015/0335071	A1	11/2015	Brinkley et al.	2016/0073678	A1	3/2016	Fujisawa et al.
2015/0335072	A1	11/2015	Giller	2016/0073690	A1	3/2016	Liu
2015/0335074	A1	11/2015	Leung	2016/0073691	A1	3/2016	Liu
2015/0335075	A1	11/2015	Minskoff et al.	2016/0073692	A1	3/2016	Alarcon et al.
2015/0342254	A1	12/2015	Mironov et al.	2016/0073693	A1	3/2016	Reevell
2015/0342255	A1	12/2015	Wu	2016/0073694	A1	3/2016	Liu
2015/0342256	A1	12/2015	Chen	2016/0080469	A1	3/2016	Liu
2015/0342257	A1	12/2015	Chen	2016/0081393	A1	3/2016	Black
2015/0342258	A1	12/2015	Chen	2016/0081394	A1	3/2016	Alarcon et al.
				2016/0081395	A1	3/2016	Thorens et al.
				2016/0088874	A1	3/2016	Lipowicz
				2016/0089508	A1	3/2016	Smith et al.
				2016/0091194	A1	3/2016	Liu
				2016/0095352	A1	4/2016	Liu



(56)

## References Cited

## U.S. PATENT DOCUMENTS

2016/0095353	A1	4/2016	Liu	2016/0165955	A1	6/2016	Home
2016/0095354	A1	4/2016	Wu	2016/0166564	A1	6/2016	Myers et al.
2016/0095355	A1	4/2016	Hearn	2016/0167846	A1	6/2016	Zahr et al.
2016/0095356	A1	4/2016	Chan	2016/0174076	A1	6/2016	Wu
2016/0095357	A1	4/2016	Burton	2016/0174609	A1	6/2016	Mironov
2016/0099592	A1	4/2016	Gatta et al.	2016/0174611	A1	6/2016	Monsees et al.
2016/0100456	A1	4/2016	Tsai	2016/0174613	A1	6/2016	Zuber et al.
2016/0100632	A1	4/2016	Debono et al.	2016/0176564	A1	6/2016	Garthaffner
2016/0101909	A1	4/2016	Schennum et al.	2016/0177285	A1	6/2016	Voerman et al.
2016/0106144	A1	4/2016	Muehlbauer et al.	2016/0183592	A1	6/2016	Liu
2016/0106151	A1	4/2016	Swepston et al.	2016/0183593	A1	6/2016	Liu
2016/0106152	A1	4/2016	Liu	2016/0183594	A1	6/2016	Liu
2016/0106154	A1	4/2016	Lord	2016/0183595	A1	6/2016	Grimandi et al.
2016/0106155	A1	4/2016	Reevell	2016/0183597	A1	6/2016	Li et al.
2016/0106156	A1	4/2016	Qiu	2016/0189216	A1	6/2016	Liu
2016/0106936	A1	4/2016	Kimmel	2016/0192705	A1	7/2016	Borkovec et al.
2016/0109115	A1	4/2016	Lipowicz	2016/0192706	A1	7/2016	Kananen
2016/0113323	A1	4/2016	Liu	2016/0192707	A1	7/2016	Li et al.
2016/0113325	A1	4/2016	Liu	2016/0192708	A1	7/2016	DeMeritt et al.
2016/0113326	A1	4/2016	Li et al.	2016/0192709	A1	7/2016	Liu
2016/0113327	A1	4/2016	Wu	2016/0192710	A1	7/2016	Liu
2016/0120218	A1	5/2016	Schennum et al.	2016/0198759	A1	7/2016	Kuntawala et al.
2016/0120220	A1	5/2016	Malgat et al.	2016/0198763	A1	7/2016	Adkins et al.
2016/0120222	A1	5/2016	Bagai et al.	2016/0198765	A1	7/2016	Liu
2016/0120223	A1	5/2016	Keen et al.	2016/0198766	A1	7/2016	Liu
2016/0120224	A1	5/2016	Mishra et al.	2016/0198767	A1	7/2016	Verleur
2016/0120225	A1	5/2016	Mishra et al.	2016/0198768	A1	7/2016	Liu
2016/0120226	A1	5/2016	Rado	2016/0198769	A1	7/2016	Liu
2016/0120227	A1	5/2016	Levitz et al.	2016/0198770	A1	7/2016	Alarcon
2016/0120228	A1	5/2016	Rostami et al.	2016/0200463	A1	7/2016	Hodges et al.
2016/0121058	A1	5/2016	Chen	2016/0201224	A1	7/2016	Xiang
2016/0128384	A1	5/2016	Luciani et al.	2016/0204637	A1	7/2016	Alarcon et al.
2016/0128385	A1	5/2016	Lin	2016/0205998	A1	7/2016	Matsumoto et al.
2016/0128387	A1	5/2016	Chen	2016/0205999	A1	7/2016	Liu
2016/0128388	A1	5/2016	Liu	2016/0206000	A1	7/2016	Lord et al.
2016/0128389	A1	5/2016	Lamb et al.	2016/0206002	A1	7/2016	Borkovec et al.
2016/0128390	A1	5/2016	Liu	2016/0206005	A1	7/2016	Yamada et al.
2016/0129205	A1	5/2016	Shahaf et al.	2016/0206006	A1	7/2016	Li et al.
2016/0131629	A1	5/2016	Cadieaux, Jr. et al.	2016/0211693	A1	7/2016	Stevens et al.
2016/0132898	A1	5/2016	Cadieaux et al.	2016/0212520	A1	7/2016	Merenda
2016/0134143	A1	5/2016	Liu	2016/0213060	A1	7/2016	Thaler
2016/0135494	A1	5/2016	Liu et al.	2016/0213061	A1	7/2016	Liu
2016/0135500	A1	5/2016	Hearn et al.	2016/0213062	A1	7/2016	Doyle
2016/0135501	A1	5/2016	Liu	2016/0213065	A1	7/2016	Wensley et al.
2016/0135503	A1	5/2016	Liu	2016/0213066	A1	7/2016	Zitzke et al.
2016/0135504	A1	5/2016	Li et al.	2016/0213067	A1	7/2016	Hon
2016/0135505	A1	5/2016	Li et al.	2016/0213866	A1	7/2016	Tan
2016/0135506	A1	5/2016	Sanchez et al.	2016/0219932	A1	8/2016	Glaser
2016/0135507	A1	5/2016	Thorens et al.	2016/0219933	A1	8/2016	Henry, Jr. et al.
2016/0136153	A1	5/2016	Jenkins	2016/0219934	A1	8/2016	Li et al.
2016/0136213	A1	5/2016	Paul	2016/0219936	A1	8/2016	Alarcon
2016/0138795	A1	5/2016	Meinhart et al.	2016/0219937	A1	8/2016	Rado
2016/0143354	A1	5/2016	Liu	2016/0219938	A1	8/2016	Mamoun et al.
2016/0143357	A1	5/2016	Liu	2016/0221707	A1	8/2016	Xu et al.
2016/0143358	A1	5/2016	Zhu	2016/0226286	A1	8/2016	Xiang
2016/0143359	A1	5/2016	Xiang	2016/0227837	A1	8/2016	Hammel et al.
2016/0143360	A1	5/2016	Sanchez et al.	2016/0227838	A1	8/2016	Johnson et al.
2016/0143361	A1	5/2016	Juster et al.	2016/0227839	A1	8/2016	Zuber et al.
2016/0143362	A1	5/2016	Boldrini	2016/0227840	A1	8/2016	Xiang
2016/0143363	A1	5/2016	Boldrini	2016/0227841	A1	8/2016	Li et al.
2016/0143365	A1	5/2016	Liu	2016/0227842	A1	8/2016	Xiang
2016/0144458	A1	5/2016	Boldrini	2016/0233705	A1	8/2016	Liu
2016/0150820	A1	6/2016	Liu	2016/0233708	A1	8/2016	Liu
2016/0150821	A1	6/2016	Liu	2016/0235119	A1	8/2016	Liu
2016/0150823	A1	6/2016	Liu	2016/0235120	A1	8/2016	Liu
2016/0150824	A1	6/2016	Memari et al.	2016/0235121	A1	8/2016	Rogan et al.
2016/0150826	A1	6/2016	Liu	2016/0235124	A1	8/2016	Krietzman
2016/0150827	A1	6/2016	Liu	2016/0235125	A1	8/2016	Safari
2016/0150828	A1	6/2016	Goldstein et al.	2016/0242463	A1	8/2016	Liu
2016/0150872	A1	6/2016	Zayat	2016/0242464	A1	8/2016	Liu
2016/0157523	A1	6/2016	Liu	2016/0242465	A1	8/2016	Zheng et al.
2016/0157524	A1	6/2016	Bowen et al.	2016/0242466	A1	8/2016	Lord et al.
2016/0157525	A1	6/2016	Tucker et al.	2016/0242467	A1	8/2016	Vaughn
2016/0158782	A1	6/2016	Henry, Jr. et al.	2016/0242468	A1	8/2016	Liu
2016/0165952	A1	6/2016	Liu	2016/0249680	A1	9/2016	Liu
				2016/0249682	A1	9/2016	Leadley et al.
				2016/0249683	A1	9/2016	Li et al.
				2016/0249684	A1	9/2016	Liu
				2016/0255876	A1	9/2016	Rostami



(56)

## References Cited

## U.S. PATENT DOCUMENTS

2016/0255878	A1	9/2016	Huang et al.	2016/0316822	A1	11/2016	Liu
2016/0260156	A1	9/2016	Liu	2016/0321879	A1	11/2016	Oh et al.
2016/0261021	A1	9/2016	Marion et al.	2016/0323404	A1	11/2016	Liu
2016/0262443	A1	9/2016	Piccirilli et al.	2016/0324211	A1	11/2016	Yankelevich
2016/0262445	A1	9/2016	Benjak et al.	2016/0324213	A1	11/2016	Liu
2016/0262449	A1	9/2016	Liu	2016/0324215	A1	11/2016	Mironov et al.
2016/0262450	A1	9/2016	Liu	2016/0324217	A1	11/2016	Cameron
2016/0262451	A1	9/2016	Liu	2016/0324218	A1	11/2016	Wang et al.
2016/0262452	A1	9/2016	Zhu	2016/0324219	A1	11/2016	Li et al.
2016/0262453	A1	9/2016	Ampolini et al.	2016/0325055	A1	11/2016	Cameron
2016/0262454	A1	9/2016	Sears et al.	2016/0325858	A1	11/2016	Ampolini et al.
2016/0262455	A1	9/2016	Chen	2016/0331022	A1	11/2016	Cameron
2016/0262456	A1	9/2016	Borkovec et al.	2016/0331023	A1	11/2016	Cameron
2016/0262457	A1	9/2016	Borkovec et al.	2016/0331024	A1	11/2016	Cameron
2016/0262459	A1	9/2016	Monsees et al.	2016/0331025	A1	11/2016	Cameron
2016/0262526	A1	9/2016	Gonzalez	2016/0331026	A1	11/2016	Cameron
2016/0268824	A1	9/2016	Liu	2016/0331027	A1	11/2016	Cameron
2016/0270441	A1	9/2016	Lewis et al.	2016/0331028	A1	11/2016	Xu
2016/0270442	A1	9/2016	Liu	2016/0331029	A1	11/2016	Contreras
2016/0270443	A1	9/2016	Liu	2016/0331030	A1	11/2016	Ampolini et al.
2016/0270444	A1	9/2016	Lin	2016/0331032	A1	11/2016	Malgat et al.
2016/0270445	A1	9/2016	Liu	2016/0331033	A1	11/2016	Hopps et al.
2016/0270446	A1	9/2016	Shenkal et al.	2016/0331034	A1	11/2016	Cameron
2016/0270447	A1	9/2016	Borkovec	2016/0331035	A1	11/2016	Cameron
2016/0271347	A1	9/2016	Raichman	2016/0331037	A1	11/2016	Cameron
2016/0278163	A1	9/2016	Chen	2016/0331038	A1	11/2016	Farine et al.
2016/0278431	A1	9/2016	Liu	2016/0331039	A1	11/2016	Thorens et al.
2016/0278432	A1	9/2016	Liu	2016/0331040	A1	11/2016	Nakano et al.
2016/0278433	A1	9/2016	Xiang	2016/0332754	A1	11/2016	Brown et al.
2016/0278434	A1	9/2016	Liu	2016/0332783	A1	11/2016	Kim
2016/0278435	A1	9/2016	Choukroun et al.	2016/0334847	A1	11/2016	Cameron
2016/0278436	A1	9/2016	Verleur et al.	2016/0337141	A1	11/2016	Cameron
2016/0280450	A1	9/2016	Hearn et al.	2016/0337362	A1	11/2016	Cameron
2016/0284197	A1	9/2016	Liu	2016/0337444	A1	11/2016	Cameron
2016/0285983	A1	9/2016	Liu	2016/0338402	A1	11/2016	Buehler et al.
2016/0286856	A1	10/2016	Liu	2016/0338405	A1	11/2016	Liu
2016/0286858	A1	10/2016	Liu	2016/0338406	A1	11/2016	Liu
2016/0286859	A1	10/2016	Liu	2016/0338407	A1	11/2016	Kerdelmidis
2016/0286860	A1	10/2016	Flayler	2016/0338408	A1	11/2016	Guenther, Jr. et al.
2016/0286862	A1	10/2016	Silvetrini	2016/0338409	A1	11/2016	Varone
2016/0286863	A1	10/2016	Lin	2016/0338410	A1	11/2016	Batista et al.
2016/0286864	A1	10/2016	Lin	2016/0338411	A1	11/2016	Liu
2016/0286865	A1	10/2016	King et al.	2016/0338412	A1	11/2016	Monsees et al.
2016/0295913	A1	10/2016	Guo et al.	2016/0338413	A1	11/2016	Li et al.
2016/0295915	A1	10/2016	Jochowitz et al.	2016/0338945	A1	11/2016	Knight
2016/0295916	A1	10/2016	Malgat et al.	2016/0345621	A1	12/2016	Li et al.
2016/0295917	A1	10/2016	Malgat et al.	2016/0345625	A1	12/2016	Liu
2016/0295918	A1	10/2016	Liu	2016/0345626	A1	12/2016	Wong et al.
2016/0295920	A1	10/2016	Liu	2016/0345627	A1	12/2016	Liu
2016/0295922	A1	10/2016	John et al.	2016/0345628	A1	12/2016	Sabet
2016/0295923	A1	10/2016	Lin	2016/0345630	A1	12/2016	Mironov et al.
2016/0295924	A1	10/2016	Liu	2016/0345631	A1	12/2016	Monsees et al.
2016/0295925	A1	10/2016	Chen	2016/0345632	A1	12/2016	Lipowicz
2016/0295926	A1	10/2016	Zuber	2016/0345633	A1	12/2016	DePiano et al.
2016/0297341	A1	10/2016	Wallace et al.	2016/0345634	A1	12/2016	Fernando et al.
2016/0302471	A1	10/2016	Bowen et al.	2016/0345636	A1	12/2016	Liu
2016/0302483	A1	10/2016	Liu	2016/0351044	A1	12/2016	Liu
2016/0302484	A1	10/2016	Gupta et al.	2016/0353798	A1	12/2016	Liu
2016/0302485	A1	10/2016	Alima	2016/0353800	A1	12/2016	Di Carlo
2016/0302486	A1	10/2016	Eroch	2016/0353805	A1	12/2016	Hawes et al.
2016/0302487	A1	10/2016	Chen	2016/0356751	A1	12/2016	Blackley
2016/0302488	A1	10/2016	Fernando et al.	2016/0360784	A1	12/2016	Liu
2016/0309775	A1	10/2016	Parker	2016/0360785	A1	12/2016	Bless et al.
2016/0309779	A1	10/2016	Liu	2016/0360786	A1	12/2016	Bellinger et al.
2016/0309780	A1	10/2016	Chen et al.	2016/0360787	A1	12/2016	Bailey
2016/0309781	A1	10/2016	Malgat et al.	2016/0360788	A1	12/2016	Wang
2016/0309783	A1	10/2016	Hopps et al.	2016/0360789	A1	12/2016	Hawes et al.
2016/0309784	A1	10/2016	Silvestrini et al.	2016/0360790	A1	12/2016	Calfee et al.
2016/0309785	A1	10/2016	Holtz	2016/0360792	A1	12/2016	Liu
2016/0309786	A1	10/2016	Holtz et al.	2016/0360793	A1	12/2016	Liu
2016/0309789	A1	10/2016	Thomas, Jr.	2016/0363570	A1	12/2016	Blackley
2016/0315488	A1	10/2016	Moon	2016/0363917	A1	12/2016	Blackley
2016/0316818	A1	11/2016	Liu	2016/0366725	A1	12/2016	Tucker et al.
2016/0316820	A1	11/2016	Liu	2016/0366927	A1	12/2016	Liu
2016/0316821	A1	11/2016	Liu	2016/0366928	A1	12/2016	Liu
				2016/0366933	A1	12/2016	Liu
				2016/0366935	A1	12/2016	Liu
				2016/0366936	A1	12/2016	Liu
				2016/0366937	A1	12/2016	Liu



(56)

## References Cited

## U.S. PATENT DOCUMENTS

2016/0366938	A1	12/2016	Wu	2017/0035111	A1	2/2017	Slurink et al.
2016/0366939	A1	12/2016	Alarcon et al.	2017/0035112	A1	2/2017	Thorens
2016/0366940	A1	12/2016	Liu	2017/0035113	A1	2/2017	Thorens
2016/0366941	A1	12/2016	Lin	2017/0035114	A1	2/2017	Lord
2016/0366942	A1	12/2016	Liu	2017/0035115	A1	2/2017	Monsees et al.
2016/0366943	A1	12/2016	Li et al.	2017/0035117	A1	2/2017	Lin
2016/0366945	A1	12/2016	Rado	2017/0035118	A1	2/2017	Liu
2016/0366947	A1	12/2016	Monsees et al.	2017/0035119	A1	2/2017	Otto
2016/0367925	A1	12/2016	Blackley	2017/0041646	A1	2/2017	Pizzurro et al.
2016/0368670	A1	12/2016	Beardsall	2017/0042225	A1	2/2017	Liu
2016/0368677	A1	12/2016	Parsons et al.	2017/0042227	A1	2/2017	Gavriellov et al.
2016/0370335	A1	12/2016	Blackley	2017/0042228	A1	2/2017	Liu
2016/0371437	A1	12/2016	Alarcon et al.	2017/0042229	A1	2/2017	Liu
2016/0371464	A1	12/2016	Bricker	2017/0042230	A1	2/2017	Cameron
2016/0374390	A1	12/2016	Liu	2017/0042231	A1	2/2017	Cameron
2016/0374391	A1	12/2016	Liu	2017/0042242	A1	2/2017	Hon
2016/0374392	A1	12/2016	Liu	2017/0042243	A1	2/2017	Plojoux et al.
2016/0374393	A1	12/2016	Chen	2017/0042245	A1	2/2017	Buchberger et al.
2016/0374394	A1	12/2016	Hawes et al.	2017/0042246	A1	2/2017	Lau et al.
2016/0374395	A1	12/2016	Jordan et al.	2017/0042247	A1	2/2017	Xiang
2016/0374396	A1	12/2016	Jordan et al.	2017/0042248	A1	2/2017	Xiang
2016/0374397	A1	12/2016	Jordan et al.	2017/0042250	A1	2/2017	Takeuchi et al.
2016/0374398	A1	12/2016	Amir	2017/0046357	A1	2/2017	Cameron
2016/0374399	A1	12/2016	Monsees et al.	2017/0046722	A1	2/2017	Ertugrul
2016/0374400	A1	12/2016	Monsees et al.	2017/0046738	A1	2/2017	Cameron
2016/0374401	A1	12/2016	Liu	2017/0047756	A1	2/2017	Xiang
2017/0000190	A1	1/2017	Wu	2017/0048691	A1	2/2017	Liu
2017/0000192	A1	1/2017	Li	2017/0049149	A1	2/2017	Carty
2017/0006915	A1	1/2017	Li et al.	2017/0049150	A1	2/2017	Xue et al.
2017/0006916	A1	1/2017	Liu	2017/0049151	A1	2/2017	Xue et al.
2017/0006917	A1	1/2017	Alvarez	2017/0049152	A1	2/2017	Liu
2017/0006918	A1	1/2017	Chen et al.	2017/0049153	A1	2/2017	Guo et al.
2017/0006919	A1	1/2017	Liu	2017/0049154	A1	2/2017	Batista
2017/0006920	A1	1/2017	Liu	2017/0049155	A1	2/2017	Liu
2017/0006922	A1	1/2017	Wang et al.	2017/0049156	A1	2/2017	Wang et al.
2017/0011407	A1	1/2017	Schmitz	2017/0050798	A1	2/2017	Ludewig et al.
2017/0013875	A1	1/2017	Schennum et al.	2017/0055577	A1	3/2017	Batista
2017/0013876	A1	1/2017	Schennum et al.	2017/0055579	A1	3/2017	Kuna et al.
2017/0013878	A1	1/2017	Schuler et al.	2017/0055586	A1	3/2017	Liu
2017/0013880	A1	1/2017	O'Brien et al.	2017/0055588	A1	3/2017	Cameron
2017/0013881	A1	1/2017	Liu	2017/0055589	A1	3/2017	Fernando et al.
2017/0013882	A1	1/2017	Liu	2017/0064994	A1	3/2017	Xu et al.
2017/0013883	A1	1/2017	Han et al.	2017/0064999	A1	3/2017	Perez et al.
2017/0013885	A1	1/2017	Qiu	2017/0065000	A1	3/2017	Sears et al.
2017/0014582	A1	1/2017	Skoda	2017/0065001	A1	3/2017	Li et al.
2017/0018000	A1	1/2017	Cameron	2017/0066556	A1	3/2017	Liu
2017/0019951	A1	1/2017	Louveau et al.	2017/0071249	A1	3/2017	Ampolini et al.
2017/0020188	A1	1/2017	Cameron	2017/0071251	A1	3/2017	Goch
2017/0020191	A1	1/2017	Lamb et al.	2017/0071252	A1	3/2017	Liu
2017/0020193	A1	1/2017	Davis et al.	2017/0071256	A1	3/2017	Verleur et al.
2017/0020194	A1	1/2017	Rehders	2017/0071257	A1	3/2017	Lin
2017/0020195	A1	1/2017	Cameron	2017/0071258	A1	3/2017	Li et al.
2017/0020196	A1	1/2017	Cameron	2017/0071260	A1	3/2017	Li et al.
2017/0020197	A1	1/2017	Cameron	2017/0071262	A1	3/2017	Liu
2017/0020198	A1	1/2017	Naqwi et al.	2017/0079110	A1	3/2017	Plattner
2017/0020201	A1	1/2017	Xiang	2017/0079319	A1	3/2017	Muhammed et al.
2017/0020791	A1	1/2017	Moszner et al.	2017/0079321	A1	3/2017	Golz
2017/0021969	A1	1/2017	Smith et al.	2017/0079322	A1	3/2017	Li et al.
2017/0023952	A1	1/2017	Henry, Jr. et al.	2017/0079323	A1	3/2017	Wang
2017/0027221	A1	2/2017	Liu	2017/0079324	A1	3/2017	Eksouzian
2017/0027223	A1	2/2017	Eksouzian	2017/0079327	A1	3/2017	Wu et al.
2017/0027224	A1	2/2017	Volodarsky	2017/0079328	A1	3/2017	Wu
2017/0027227	A1	2/2017	Lipowicz	2017/0079329	A1	3/2017	Zitzke
2017/0027228	A1	2/2017	Rastogi	2017/0079330	A1	3/2017	Mironov et al.
2017/0027229	A1	2/2017	Cameron	2017/0079331	A1	3/2017	Monsees et al.
2017/0027230	A1	2/2017	Fornarelli	2017/0079332	A1	3/2017	Li et al.
2017/0027231	A1	2/2017	Xiang	2017/0086496	A1	3/2017	Cameron
2017/0027232	A1	2/2017	Scheck et al.	2017/0086497	A1	3/2017	Cameron
2017/0027233	A1	2/2017	Mironov	2017/0086498	A1	3/2017	Daryani
2017/0027234	A1	2/2017	Farine et al.	2017/0086499	A1	3/2017	Mize
2017/0033568	A1	2/2017	Holzherr	2017/0086500	A1	3/2017	Li et al.
2017/0033836	A1	2/2017	Bernauer et al.	2017/0086501	A1	3/2017	Buehler et al.
2017/0035101	A1	2/2017	Balder	2017/0086502	A1	3/2017	Hearn et al.
2017/0035109	A1	2/2017	Liu	2017/0086503	A1	3/2017	Cameron
2017/0035110	A1	2/2017	Keen	2017/0086504	A1	3/2017	Cameron
				2017/0086505	A1	3/2017	Cameron
				2017/0086506	A1	3/2017	Rado
				2017/0086507	A1	3/2017	Rado
				2017/0086508	A1	3/2017	Mironov et al.



(56)

## References Cited

## U.S. PATENT DOCUMENTS

2017/0091490	A1	3/2017	Cameron	2017/0136301	A1	5/2017	Cameron
2017/0091853	A1	3/2017	Cameron	2017/0143035	A1	5/2017	Pucci
2017/0092106	A1	3/2017	Cameron	2017/0143037	A9	5/2017	Larson
2017/0092900	A1	3/2017	Yang	2017/0143038	A1	5/2017	Dickens
2017/0093960	A1	3/2017	Cameron	2017/0143040	A1	5/2017	Liu
2017/0093981	A1	3/2017	Cameron	2017/0143043	A1	5/2017	Liu
2017/0094998	A1	4/2017	Bernauer et al.	2017/0143917	A1	5/2017	Cohen et al.
2017/0094999	A1	4/2017	Hearn et al.	2017/0144827	A1	5/2017	Batista
2017/0095000	A1	4/2017	Spirito et al.	2017/0146005	A1	5/2017	Edelen
2017/0095001	A1	4/2017	Liu	2017/0150753	A1	6/2017	MacKo
2017/0095002	A1	4/2017	Silvestrini	2017/0150754	A1	6/2017	Lin
2017/0095003	A1	4/2017	Mironov	2017/0150755	A1	6/2017	Batista
2017/0095004	A1	4/2017	Liu	2017/0150756	A1	6/2017	Rexroad et al.
2017/0095005	A1	4/2017	Monsees et al.	2017/0150758	A1	6/2017	Fernando et al.
2017/0095518	A1	4/2017	Bjorncrantz	2017/0156397	A1	6/2017	Sur et al.
2017/0095623	A1	4/2017	Trzecieski	2017/0156398	A1	6/2017	Sur et al.
2017/0099877	A1	4/2017	Worm et al.	2017/0156400	A1	6/2017	Liu
2017/0099879	A1	4/2017	Heidl	2017/0156401	A1	6/2017	Liu
2017/0099880	A1	4/2017	Hawes	2017/0156402	A1	6/2017	Liu
2017/0101256	A1	4/2017	Zeitlin et al.	2017/0156403	A1	6/2017	Gill et al.
2017/0102013	A1	4/2017	Wallman et al.	2017/0156404	A1	6/2017	Novak, III et al.
2017/0105448	A1	4/2017	Scarpulla	2017/0156408	A1	6/2017	Li et al.
2017/0105449	A1	4/2017	Hearn et al.	2017/0158436	A1	6/2017	Slurink
2017/0105450	A1	4/2017	Reed et al.	2017/0162523	A1	6/2017	Hu
2017/0105451	A1	4/2017	Fornarelli	2017/0162979	A1	6/2017	Liu
2017/0105452	A1	4/2017	Mironov et al.	2017/0164655	A1	6/2017	Chen
2017/0105453	A1	4/2017	Li et al.	2017/0164656	A1	6/2017	Eusepi et al.
2017/0105454	A1	4/2017	Li et al.	2017/0164657	A1	6/2017	Batista
2017/0105455	A1	4/2017	Qiu	2017/0164658	A1	6/2017	Lin et al.
2017/0108210	A1	4/2017	Meinhart et al.	2017/0170439	A1	6/2017	Jarvis et al.
2017/0108840	A1	4/2017	Hawes et al.	2017/0172204	A1	6/2017	Kane et al.
2017/0109877	A1	4/2017	Peleg et al.	2017/0172205	A1	6/2017	Chang et al.
2017/0112182	A1	4/2017	Arnold	2017/0172207	A1	6/2017	Liu
2017/0112190	A1	4/2017	Buchberger	2017/0172208	A1	6/2017	Mironov
2017/0112192	A1	4/2017	Shan	2017/0172209	A1	6/2017	Saydar et al.
2017/0112193	A1	4/2017	Chen	2017/0172213	A1	6/2017	Hon
2017/0112196	A1	4/2017	Sur et al.	2017/0172214	A1	6/2017	Li et al.
2017/0112197	A1	4/2017	Li et al.	2017/0172215	A1	6/2017	Li et al.
2017/0113819	A1	4/2017	Marz	2017/0181223	A1	6/2017	Sur et al.
2017/0117654	A1	4/2017	Cruz	2017/0181467	A1	6/2017	Cameron
2017/0118292	A1	4/2017	Xiang	2017/0181468	A1	6/2017	Bowen et al.
2017/0118584	A1	4/2017	Xiang	2017/0181470	A1	6/2017	Li
2017/0119040	A1	5/2017	Cameron	2017/0181471	A1	6/2017	Phillips et al.
2017/0119044	A1	5/2017	Oligschlaeger et al.	2017/0181473	A1	6/2017	Batista et al.
2017/0119050	A1	5/2017	Blandino et al.	2017/0181474	A1	6/2017	Cameron
2017/0119052	A1	5/2017	Williams et al.	2017/0181475	A1	6/2017	Cameron
2017/0119053	A1	5/2017	Henry, Jr. et al.	2017/0181476	A1	6/2017	Li et al.
2017/0119054	A1	5/2017	Zinovik et al.	2017/0181928	A1	6/2017	Collins et al.
2017/0119055	A1	5/2017	Liu	2017/0185364	A1	6/2017	Cameron
2017/0119057	A1	5/2017	Liu	2017/0186122	A1	6/2017	Levings et al.
2017/0119058	A1	5/2017	Cameron	2017/0188626	A1	7/2017	Davis et al.
2017/0119060	A1	5/2017	Li et al.	2017/0188627	A1	7/2017	Sur
2017/0119061	A1	5/2017	Li et al.	2017/0188628	A1	7/2017	Montgomery
2017/0127722	A1	5/2017	Davis et al.	2017/0188629	A1	7/2017	Dickens et al.
2017/0127723	A1	5/2017	Wu	2017/0188631	A1	7/2017	Lin
2017/0127724	A1	5/2017	Liu	2017/0188632	A1	7/2017	Hon
2017/0127725	A1	5/2017	Buchberger et al.	2017/0188634	A1	7/2017	Plojoux et al.
2017/0127726	A1	5/2017	Xiang	2017/0188635	A1	7/2017	Force et al.
2017/0127728	A1	5/2017	Li et al.	2017/0188636	A1	7/2017	Li et al.
2017/0129661	A1	5/2017	Van Tassell, III et al.	2017/0196263	A1	7/2017	Sur
2017/0135397	A1	5/2017	Buehler et al.	2017/0196264	A1	7/2017	Liu
2017/0135398	A1	5/2017	Scott et al.	2017/0196265	A1	7/2017	Liu
2017/0135399	A1	5/2017	Gavriellov et al.	2017/0196267	A1	7/2017	Zou et al.
2017/0135400	A1	5/2017	Liu	2017/0196268	A1	7/2017	Reevell
2017/0135401	A1	5/2017	Dickens	2017/0196269	A1	7/2017	Bernauer et al.
2017/0135402	A1	5/2017	Zitzke	2017/0196270	A1	7/2017	Vick et al.
2017/0135403	A1	5/2017	Liu	2017/0196271	A1	7/2017	Levitz et al.
2017/0135407	A1	5/2017	Cameron	2017/0196272	A1	7/2017	Li et al.
2017/0135408	A1	5/2017	Cameron	2017/0196273	A1	7/2017	Qiu
2017/0135409	A1	5/2017	Cameron	2017/0202265	A1	7/2017	Hawes et al.
2017/0135410	A1	5/2017	Cameron	2017/0202266	A1	7/2017	Sur
2017/0135411	A1	5/2017	Cameron	2017/0202267	A1	7/2017	Liu
2017/0135412	A1	5/2017	Cameron	2017/0202268	A1	7/2017	Li et al.
2017/0136193	A1	5/2017	Cameron	2017/0207499	A1	7/2017	Leadley
2017/0136194	A1	5/2017	Cameron	2017/0208857	A1	7/2017	Branton et al.
				2017/0208858	A1	7/2017	Li
				2017/0208862	A1	7/2017	Li et al.
				2017/0208863	A1	7/2017	Davis et al.
				2017/0208864	A1	7/2017	Anderson, Jr. et al.



(56)

## References Cited

## U.S. PATENT DOCUMENTS

2017/0208865	A1	7/2017	Nettenstrom et al.	2017/0251719	A1	9/2017	Cyphert et al.
2017/0208866	A1	7/2017	Liu	2017/0251721	A1	9/2017	Rostami et al.
2017/0208867	A1	7/2017	Li et al.	2017/0251722	A1	9/2017	Kobal et al.
2017/0208868	A1	7/2017	Li et al.	2017/0251723	A1	9/2017	Kobal et al.
2017/0208869	A1	7/2017	Li et al.	2017/0251724	A1	9/2017	Lamb et al.
2017/0208870	A1	7/2017	Liu	2017/0251725	A1	9/2017	Buchberger et al.
2017/0208882	A1	7/2017	Lambertz	2017/0251726	A1	9/2017	Nielsen
2017/0214261	A1	7/2017	Gratton	2017/0251727	A1	9/2017	Nielsen
2017/0215470	A1	8/2017	Piccirilli et al.	2017/0251728	A1	9/2017	Peleg et al.
2017/0215473	A1	8/2017	Nakano et al.	2017/0251729	A1	9/2017	Li et al.
2017/0215474	A1	8/2017	Li	2017/0258129	A1	9/2017	Haun
2017/0215476	A1	8/2017	Dickens et al.	2017/0258132	A1	9/2017	Rostami et al.
2017/0215477	A1	8/2017	Reevell	2017/0258134	A1	9/2017	Kane
2017/0215478	A1	8/2017	Harrison et al.	2017/0258137	A1	9/2017	Smith et al.
2017/0215479	A1	8/2017	Kies	2017/0258138	A1	9/2017	Rostami et al.
2017/0215480	A1	8/2017	Qiu	2017/0258139	A1	9/2017	Rostami et al.
2017/0215481	A1	8/2017	Li et al.	2017/0258140	A1	9/2017	Rostami et al.
2017/0215482	A1	8/2017	Levitz et al.	2017/0258142	A1	9/2017	Hatton et al.
2017/0215483	A1	8/2017	Li et al.	2017/0258143	A1	9/2017	Lederer
2017/0215484	A1	8/2017	Xiang	2017/0259170	A1	9/2017	Bowen et al.
2017/0215485	A1	8/2017	Zitzke	2017/0259954	A1	9/2017	Schwester
2017/0217607	A1	8/2017	Slurink	2017/0261200	A1	9/2017	Stultz
2017/0219199	A1	8/2017	Lou et al.	2017/0265517	A1	9/2017	Swede et al.
2017/0219391	A1	8/2017	Lin et al.	2017/0265522	A1	9/2017	Li et al.
2017/0222468	A1	8/2017	Schennum et al.	2017/0265524	A1	9/2017	Cadieux et al.
2017/0224013	A1	8/2017	Huang	2017/0265525	A1	9/2017	Li et al.
2017/0224014	A1	8/2017	Fraser	2017/0266397	A1	9/2017	Mayle et al.
2017/0224016	A1	8/2017	Reevell	2017/0273353	A1	9/2017	Gindrat
2017/0224017	A1	8/2017	Li et al.	2017/0273354	A1	9/2017	Tucker et al.
2017/0224018	A1	8/2017	Li et al.	2017/0273355	A1	9/2017	Rogers et al.
2017/0224022	A1	8/2017	Liu	2017/0273357	A1	9/2017	Barbuck
2017/0224023	A1	8/2017	Lin et al.	2017/0273358	A1	9/2017	Batista et al.
2017/0224024	A1	8/2017	Jochowitz et al.	2017/0273359	A1	9/2017	Liu
2017/0229885	A1	8/2017	Bernauer	2017/0273360	A1	9/2017	Brinkley et al.
2017/0229888	A1	8/2017	Liu	2017/0273361	A1	9/2017	Li et al.
2017/0231266	A1	8/2017	Mishra et al.	2017/0273914	A1	9/2017	Knudsen
2017/0231267	A1	8/2017	Shi et al.	2017/0280767	A1	10/2017	Li et al.
2017/0231269	A1	8/2017	Besso et al.	2017/0280768	A1	10/2017	Lipowicz
2017/0231273	A1	8/2017	Xiang	2017/0280769	A1	10/2017	Li et al.
2017/0231275	A1	8/2017	Guenther	2017/0280770	A1	10/2017	Wang et al.
2017/0231276	A1	8/2017	Mironov et al.	2017/0280771	A1	10/2017	Courbat et al.
2017/0231277	A1	8/2017	Mironov et al.	2017/0280775	A1	10/2017	Manca et al.
2017/0231278	A1	8/2017	Mironov et al.	2017/0280776	A1	10/2017	Manca et al.
2017/0231279	A1	8/2017	Watson	2017/0280778	A1	10/2017	Force
2017/0231280	A1	8/2017	Anton	2017/0281883	A1	10/2017	Li et al.
2017/0231281	A1	8/2017	Hatton et al.	2017/0283154	A1	10/2017	Karles et al.
2017/0231282	A1	8/2017	Bowen et al.	2017/0285810	A1	10/2017	Krah
2017/0231283	A1	8/2017	Gadas	2017/0290368	A1	10/2017	Hearn
2017/0231284	A1	8/2017	Newns	2017/0290369	A1	10/2017	Norasak
2017/0231285	A1	8/2017	Holzherr et al.	2017/0290370	A1	10/2017	Garthaffner et al.
2017/0231286	A1	8/2017	Borkovec et al.	2017/0290371	A1	10/2017	Davis et al.
2017/0233114	A1	8/2017	Christensen et al.	2017/0290373	A1	10/2017	Hon
2017/0238596	A1	8/2017	Matsumoto et al.	2017/0290998	A1	10/2017	Poston et al.
2017/0238605	A1	8/2017	Matsumoto et al.	2017/0295840	A1	10/2017	Rath et al.
2017/0238606	A1	8/2017	Matsumoto et al.	2017/0295843	A1	10/2017	Storch
2017/0238608	A1	8/2017	Matsumoto et al.	2017/0295844	A1	10/2017	Thevenaz et al.
2017/0238609	A1	8/2017	Schlipf	2017/0295845	A1	10/2017	Bajpai et al.
2017/0238611	A1	8/2017	Buchberger	2017/0295846	A1	10/2017	Liu
2017/0238612	A1	8/2017	Daryani et al.	2017/0295847	A1	10/2017	Liu
2017/0238613	A1	8/2017	Suess et al.	2017/0295848	A1	10/2017	LaMothe
2017/0238614	A1	8/2017	Li et al.	2017/0295849	A1	10/2017	Cadieux et al.
2017/0238617	A1	8/2017	Scatterday	2017/0297892	A1	10/2017	Li et al.
2017/0241857	A1	8/2017	Hearn et al.	2017/0301898	A1	10/2017	Lin et al.
2017/0245543	A1	8/2017	Karles et al.	2017/0302089	A1	10/2017	Bernauer et al.
2017/0245546	A1	8/2017	Huang	2017/0302324	A1	10/2017	Stanimirovic et al.
2017/0245547	A1	8/2017	Lipowicz	2017/0303597	A1	10/2017	Tsui
2017/0245550	A1	8/2017	Freeland	2017/0311648	A1	11/2017	Gill et al.
2017/0245551	A1	8/2017	Reevell	2017/0318860	A1	11/2017	Adair
2017/0245554	A1	8/2017	Perez et al.	2017/0318861	A1	11/2017	Thorens
2017/0246399	A1	8/2017	Forlani et al.	2017/0325503	A1	11/2017	Liu
2017/0246405	A1	8/2017	Wensley et al.	2017/0325504	A1	11/2017	Liu
2017/0246407	A1	8/2017	Matsumoto et al.	2017/0325506	A1	11/2017	Batista
2017/0250552	A1	8/2017	Liu	2017/0332695	A1	11/2017	Zappoli et al.
2017/0251714	A1	9/2017	Mishra et al.	2017/0333415	A1	11/2017	Williams
2017/0251718	A1	9/2017	Armouh et al.	2017/0333650	A1	11/2017	Buchberger et al.
				2017/0333651	A1	11/2017	Qiu
				2017/0334605	A1	11/2017	Murphy et al.
				2017/0367406	A1	12/2017	Schuler et al.
				2018/0000160	A1	1/2018	Taschner et al.



(56)

References Cited

U.S. PATENT DOCUMENTS

2018/0037381 A1 2/2018 White et al.  
 2018/0042306 A1 2/2018 Atkins et al.  
 2018/0043114 A1\* 2/2018 Bowen ..... A61M 15/003  
 2018/0043115 A1 2/2018 Gould et al.  
 2018/0077967 A1 3/2018 Hatton et al.  
 2018/0093050 A1 4/2018 Stenzler et al.  
 2018/0093051 A1 4/2018 Stenzler et al.  
 2018/0098571 A1\* 4/2018 Watson ..... A24F 47/008  
 2018/0153218 A1 6/2018 Verleur et al.  
 2018/0153219 A1 6/2018 Verleur et al.  
 2018/0153220 A1 6/2018 Verleur et al.  
 2018/0153221 A1 6/2018 Verleur et al.  
 2018/0279682 A1\* 10/2018 Guo ..... A24F 47/008  
 2019/0029319 A1\* 1/2019 Moorman ..... A24F 7/04  
 2019/0116881 A1\* 4/2019 Sherwood ..... A24F 47/008

FOREIGN PATENT DOCUMENTS

AU 2017202891 A1 5/2017  
 CA 2641869 A1 5/2010  
 CN 1122213 A 5/1996  
 CN 201018481 Y 2/2008  
 CN 201430916 Y 3/2010  
 CN 101869356 A 10/2010  
 CN 301547686 S 5/2011  
 CN 202004499 U 10/2011  
 CN 202218034 U 5/2012  
 CN 301970169 S 6/2012  
 CN 102754924 A 10/2012  
 CN 202663148 U 1/2013  
 CN 302396126 S 4/2013  
 CN 103141944 A 6/2013  
 CN 203327953 U 12/2013  
 CN 302799554 S 4/2014  
 CN 302810246 S 4/2014  
 CN 302835832 6/2014  
 CN 302844066 6/2014  
 CN 302884434 S 8/2014  
 CN 302926289 S 8/2014  
 CN 302950830 S 9/2014  
 CN 303089422 S 1/2015  
 CN 303091331 S 1/2015  
 CN 303210086 S 5/2015  
 CN 303103389 S 11/2015  
 CN 303568163 S 1/2016  
 CN 303103390 S 2/2016  
 DE 9410665 U1 10/1994  
 DE 19854005 A1 5/2000  
 DE 19854012 A1 5/2000  
 EM 002307942-0001 9/2013  
 EM 002307942-0002 9/2013  
 EM 002307942-0003 9/2013  
 EM 002626416-001 4/2015  
 EM 002626416-002 4/2015  
 EP 0283672 A2 9/1988  
 EP 0358114 A2 3/1990  
 EP 0503767 A1 9/1992  
 EP 0532194 A1 3/1993  
 EP 0535695 A2 4/1993  
 EP 0762258 A2 3/1997  
 EP 2110033 A1 10/2009  
 EP 2186507 A2 5/2010  
 EP 2399636 A1 12/2011  
 EP 2573900 A1 3/2013  
 EP 2614731 A1 7/2013  
 EP 2711006 A1 3/2014  
 EP 2641669 B1 5/2014  
 EP 2789248 A1 10/2014  
 EP 2493342 B1 12/2014  
 EP 2856893 A1 4/2015  
 EP 2862454 A1 4/2015  
 EP 2862457 A1 4/2015  
 EP 2944206 A1 11/2015  
 EP 2952110 A1 12/2015  
 EP 2989912 A1 3/2016

EP 3001918 A1 4/2016  
 EP 3007305 A1 4/2016  
 EP 3012213 A1 4/2016  
 EP 3016233 A1 5/2016  
 EP 3023016 A1 5/2016  
 EP 3023351 A1 5/2016  
 EP 3023947 A1 5/2016  
 EP 3025598 A1 6/2016  
 EP 3026779 A1 6/2016  
 EP 3031338 A1 6/2016  
 EP 3047742 A1 7/2016  
 EP 3056099 A1 8/2016  
 EP 3061358 A1 8/2016  
 EP 3075270 A1 10/2016  
 EP 3075271 A1 10/2016  
 EP 3081102 A1 10/2016  
 EP 3085638 A1 10/2016  
 EP 3087853 A1 11/2016  
 EP 3097803 A1 11/2016  
 EP 3103355 A1 12/2016  
 EP 3103356 A1 12/2016  
 EP 3111787 A1 1/2017  
 EP 3130238 A1 2/2017  
 EP 3132843 A1 2/2017  
 EP 3135139 A1 3/2017  
 EP 3135603 A1 3/2017  
 EP 3143882 A3 3/2017  
 EP 3143884 A3 4/2017  
 EP 3155908 A1 4/2017  
 EP 3158880 A1 4/2017  
 EP 3158881 A1 4/2017  
 EP 3195738 A2 7/2017  
 EP 3165102 A3 8/2017  
 EP 3199043 A1 8/2017  
 EP 3205220 A1 8/2017  
 EP 3205597 A1 8/2017  
 EP 3213649 A1 9/2017  
 EP 3225118 A1 10/2017  
 EP 3228198 A1 10/2017  
 EP 3228345 A1 10/2017  
 ES 2118034 A1 9/1998  
 GB 1025630 A 4/1966  
 GB 1065678 A 4/1967  
 GB 2533174 A 6/2016  
 IE S20050615 9/2005  
 JP 62278975 12/1987  
 JP H06114105 A 4/1994  
 JP 09-075058 3/1997  
 JP H09075058 A 3/1997  
 JP 11178563 6/1999  
 JP 2000203639 A 7/2000  
 JP 2000236865 A 9/2000  
 JP 2001161819 A 6/2001  
 JP 2001165437 A 6/2001  
 JP 2006320285 A 11/2006  
 JP 2006320286 A 11/2006  
 JP 2009213428 A 9/2009  
 JP 2010020929 A 1/2010  
 JP 2011024430 A 2/2011  
 JP 2012005412 A 1/2012  
 JP 5387257 B2 1/2014  
 JP 2015504669 A 2/2015  
 JP 201712730 A 1/2017  
 KR 1020120132004 12/2012  
 KR 101357574 B1 2/2014  
 KR 3007450290000 5/2014  
 KR 101570876 B1 11/2015  
 KR 101677435 B1 11/2016  
 RU 2013503569 4/2015  
 TW 201436722 A 10/2014  
 TW 201438608 A 10/2014  
 TW 201524383 A 7/2015  
 WO WO-9712639 A1 4/1997  
 WO WO-2000005976 A1 2/2000  
 WO WO-0028842 A1 5/2000  
 WO WO-03055486 A1 7/2003  
 WO WO-03056948 A1 7/2003  
 WO WO-03082031 A1 10/2003  
 WO WO-03101454 A1 12/2003



(56)

## References Cited

## FOREIGN PATENT DOCUMENTS

WO	WO-2004064548	A1	8/2004	WO	WO-2014127446	A1	8/2014
WO	WO-2004080216	A1	9/2004	WO	WO-2014134781	A1	9/2014
WO	WO-2005020726	A1	3/2005	WO	WO-2014144678	A2	9/2014
WO	WO-2005060366	A2	7/2005	WO	WO-2014146270	A1	9/2014
WO	WO-2006021153	A1	3/2006	WO	WO-2014147470	A2	9/2014
WO	WO-2007066374	A1	6/2007	WO	WO-2014150979	A2	9/2014
WO	WO-2007078273	A1	7/2007	WO	WO-2014161181	A1	10/2014
WO	WO-2007095109	A2	8/2007	WO	WO-2014166039	A1	10/2014
WO	WO-2007117675	A2	10/2007	WO	WO-2014167530	A1	10/2014
WO	WO-2007/141520	A1	12/2007	WO	WO-2014169437	A1	10/2014
WO	WO-2008077271	A1	7/2008	WO	WO-2014169667	A1	10/2014
WO	WO-2008151777	A2	12/2008	WO	WO-2014185937	A1	11/2014
WO	WO-2009003204	A2	1/2009	WO	WO-2014186983	A1	11/2014
WO	WO-2010003480	A1	1/2010	WO	WO-2014194499	A1	12/2014
WO	WO-2010118122	A1	10/2010	WO	WO-2014195687	A1	12/2014
WO	WO-2010118644	A1	10/2010	WO	WO-2014198042	A1	12/2014
WO	WO-2010140841	A2	12/2010	WO	WO-2014201610	A1	12/2014
WO	WO-2010144637	A1	12/2010	WO	WO-2014201611	A1	12/2014
WO	WO-2010145805	A1	12/2010	WO	WO-2014201646	A1	12/2014
WO	WO-2011010334	A1	1/2011	WO	WO-2014201664	A1	12/2014
WO	WO-2011050964	A1	5/2011	WO	WO-2014201666	A1	12/2014
WO	WO-2011125058	A1	10/2011	WO	WO-2014201668	A1	12/2014
WO	WO-2012019533	A1	2/2012	WO	WO-2014205749	A1	12/2014
WO	WO-2012043941	A1	4/2012	WO	WO-2014205780	A1	12/2014
WO	WO-2012062600	A1	5/2012	WO	WO-2014205807	A1	12/2014
WO	WO-2012088675	A1	7/2012	WO	WO-2014205811	A1	12/2014
WO	WO-2012091249	A1	7/2012	WO	WO-2014206148	A1	12/2014
WO	WO-2012100523	A1	8/2012	WO	WO-2015000125	A1	1/2015
WO	WO-2012129812	A1	10/2012	WO	WO-2015000180	A1	1/2015
WO	WO-2012134117	A2	10/2012	WO	WO-2015003327	A1	1/2015
WO	WO-2012164033	A1	12/2012	WO	WO-2015003372	A1	1/2015
WO	WO-2012173322	A1	12/2012	WO	WO-2015003374	A1	1/2015
WO	WO-2012174677	A1	12/2012	WO	WO-2015006929	A1	1/2015
WO	WO-D079112-0010		12/2012	WO	WO-2015010242	A1	1/2015
WO	WO-2013012157	A1	1/2013	WO	WO-2015010277	A1	1/2015
WO	WO-2013020220	A1	2/2013	WO	WO-2015010284	A1	1/2015
WO	WO-2013030202	A1	3/2013	WO	WO-2015010291	A1	1/2015
WO	WO-2013034453	A1	3/2013	WO	WO-2015010310	A1	1/2015
WO	WO-2013040193	A2	3/2013	WO	WO-2015010336	A1	1/2015
WO	WO-2013044537	A1	4/2013	WO	WO-2015010345	A1	1/2015
WO	WO-2013076750	A1	5/2013	WO	WO-2015010349	A1	1/2015
WO	WO-2013083635	A1	6/2013	WO	WO-2015013890	A1	2/2015
WO	WO-2013089551	A1	6/2013	WO	WO-2015013891	A1	2/2015
WO	WO-2013110208	A1	8/2013	WO	WO-2015013892	A1	2/2015
WO	WO-2013110209	A1	8/2013	WO	WO-2015013926	A1	2/2015
WO	WO-2013110210	A1	8/2013	WO	WO-2015013950	A1	2/2015
WO	WO-2013113173	A1	8/2013	WO	WO-2015013967	A1	2/2015
WO	WO-2013113174	A1	8/2013	WO	WO-2015015156	A1	2/2015
WO	WO-2013113612	A1	8/2013	WO	WO-2015017971	A1	2/2015
WO	WO-2013116983	A1	8/2013	WO	WO-2015018026	A1	2/2015
WO	WO-2013131763	A1	9/2013	WO	WO-2015018120	A1	2/2015
WO	WO-2013142678	A1	9/2013	WO	WO-2015021612	A1	2/2015
WO	WO-2013150406	A2	10/2013	WO	WO-2015021646	A1	2/2015
WO	WO-2013156658	A1	10/2013	WO	WO-2015021651	A1	2/2015
WO	WO-2013165878	A1	11/2013	WO	WO-2015021652	A1	2/2015
WO	WO-2013171206	A1	11/2013	WO	WO-2015021655	A1	2/2015
WO	WO-2013174001	A1	11/2013	WO	WO-2015021658	A1	2/2015
WO	WO-2014020539	A1	2/2014	WO	WO-2015024239	A1	2/2015
WO	WO-2014020953	A1	2/2014	WO	WO-2015024247	A1	2/2015
WO	WO-2014023171	A1	2/2014	WO	WO-2015026081	A1	2/2015
WO	WO-2014032280	A1	3/2014	WO	WO-2015027383	A1	3/2015
WO	WO-2014040915	A1	3/2014	WO	WO-2015027435	A1	3/2015
WO	WO-2014047948	A1	4/2014	WO	WO-2015027436	A1	3/2015
WO	WO-2014047955	A1	4/2014	WO	WO-2015027470	A1	3/2015
WO	WO-2014067236	A1	5/2014	WO	WO-2015028815	A1	3/2015
WO	WO-2014071747	A1	5/2014	WO	WO-2015032050	A1	3/2015
WO	WO-2014101119	A1	7/2014	WO	WO-2015032055	A1	3/2015
WO	WO-2014101401	A1	7/2014	WO	WO-2015032078	A1	3/2015
WO	WO-2014101734	A1	7/2014	WO	WO-2015032093	A1	3/2015
WO	WO-2014106323	A1	7/2014	WO	WO-2015035510	A1	3/2015
WO	WO-2014110761	A1	7/2014	WO	WO-2015035547	A1	3/2015
WO	WO-2014113949	A1	7/2014	WO	WO-2015035557	A1	3/2015
WO	WO-2014117382	A1	8/2014	WO	WO-2015035587	A1	3/2015
WO	WO-2014121509	A1	8/2014	WO	WO-2015035623	A1	3/2015
WO	WO-2014125340	A1	8/2014	WO	WO-2015035689	A1	3/2015
				WO	WO-2015035689	A1	3/2015
				WO	WO-2015037925	A1	3/2015
				WO	WO-2015039275	A1	3/2015
				WO	WO-2015039280	A1	3/2015
				WO	WO-2015039332	A1	3/2015



(56)

## References Cited

## FOREIGN PATENT DOCUMENTS

WO	WO-2015042790	A1	4/2015	WO	WO-2015161407	A1	10/2015
WO	WO-2015042811	A1	4/2015	WO	WO-2015161485	A1	10/2015
WO	WO-2015042848	A1	4/2015	WO	WO-2015161486	A1	10/2015
WO	WO-2015042943	A1	4/2015	WO	WO-2015161491	A1	10/2015
WO	WO-2015051509	A1	4/2015	WO	WO-2015161514	A1	10/2015
WO	WO-2015051538	A1	4/2015	WO	WO-2015161553	A1	10/2015
WO	WO-2015054815	A1	4/2015	WO	WO-2015161555	A1	10/2015
WO	WO-2015054862	A1	4/2015	WO	WO-2015161557	A1	10/2015
WO	WO-2015054961	A1	4/2015	WO	WO-2015068044	A3	11/2015
WO	WO-2015055314	A1	4/2015	WO	WO-2015165067	A1	11/2015
WO	WO-2015058340	A1	4/2015	WO	WO-2015165081	A1	11/2015
WO	WO-2015058341	A1	4/2015	WO	WO-2015165083	A1	11/2015
WO	WO-2015058367	A1	4/2015	WO	WO-2015165086	A1	11/2015
WO	WO-2015058387	A1	4/2015	WO	WO-2015165105	A1	11/2015
WO	WO-2015062041	A1	5/2015	WO	WO-2015165146	A1	11/2015
WO	WO-2015066136	A1	5/2015	WO	WO-2015168827	A1	11/2015
WO	WO-2015066927	A1	5/2015	WO	WO-2015168828	A1	11/2015
WO	WO-2015070398	A1	5/2015	WO	WO-2015168853	A1	11/2015
WO	WO-2015070405	A1	5/2015	WO	WO-2015168904	A1	11/2015
WO	WO-2015071703	A1	5/2015	WO	WO-2015168912	A1	11/2015
WO	WO-2015073975	A1	5/2015	WO	WO-2015172331	A1	11/2015
WO	WO-2015074187	A1	5/2015	WO	WO-2015172361	A1	11/2015
WO	WO-2015074265	A1	5/2015	WO	WO-2015172368	A1	11/2015
WO	WO-2015074308	A1	5/2015	WO	WO-2015172382	A1	11/2015
WO	WO-2015077998	A1	6/2015	WO	WO-2015172383	A1	11/2015
WO	WO-2015077999	A1	6/2015	WO	WO-2015172384	A1	11/2015
WO	WO-2015078010	A1	6/2015	WO	WO-2015172387	A1	11/2015
WO	WO-2015079197	A1	6/2015	WO	WO-2015172388	A1	11/2015
WO	WO-2015089711	A1	6/2015	WO	WO-2015172389	A1	11/2015
WO	WO-2015091346	A2	6/2015	WO	WO-2015172390	A1	11/2015
WO	WO-2015013327	A3	7/2015	WO	WO-2015172606	A1	11/2015
WO	WO-2015106434	A1	7/2015	WO	WO-2015174657	A1	11/2015
WO	WO-2015106440	A1	7/2015	WO	WO-2015174708	A1	11/2015
WO	WO-2015107551	A2	7/2015	WO	WO-2015175979	A1	11/2015
WO	WO-2015107552	A1	7/2015	WO	WO-2015176210	A1	11/2015
WO	WO-2015109476	A1	7/2015	WO	WO-2015176230	A1	11/2015
WO	WO-2015109532	A1	7/2015	WO	WO-2015176300	A1	11/2015
WO	WO-2015109540	A1	7/2015	WO	WO-2015176580	A1	11/2015
WO	WO-2015109616	A1	7/2015	WO	WO-2015180027	A1	12/2015
WO	WO-2015109618	A1	7/2015	WO	WO-2015180061	A1	12/2015
WO	WO-2015117285	A1	8/2015	WO	WO-2015180062	A1	12/2015
WO	WO-2015120588	A1	8/2015	WO	WO-2015180071	A1	12/2015
WO	WO-2015120591	A1	8/2015	WO	WO-2015180088	A1	12/2015
WO	WO-2015120623	A1	8/2015	WO	WO-2015180089	A1	12/2015
WO	WO-2015123831	A1	8/2015	WO	WO-2015180145	A1	12/2015
WO	WO-2015127609	A1	9/2015	WO	WO-2015184580	A1	12/2015
WO	WO-2015128599	A1	9/2015	WO	WO-2015184590	A1	12/2015
WO	WO-2015137815	A1	9/2015	WO	WO-2015184620	A1	12/2015
WO	WO-2015140312	A1	9/2015	WO	WO-2015184747	A1	12/2015
WO	WO-2015140336	A1	9/2015	WO	WO-2015188295	A1	12/2015
WO	WO-2015140768	A2	9/2015	WO	WO-2015188296	A1	12/2015
WO	WO-2015143637	A1	10/2015	WO	WO-2015189613	A1	12/2015
WO	WO-2015143648	A1	10/2015	WO	WO-2015190810	A1	12/2015
WO	WO-2015143749	A1	10/2015	WO	WO-2015192301	A1	12/2015
WO	WO-2015143765	A1	10/2015	WO	WO-2015192326	A1	12/2015
WO	WO-2015144057	A1	10/2015	WO	WO-2015192336	A1	12/2015
WO	WO-2015144328	A1	10/2015	WO	WO-2015192337	A1	12/2015
WO	WO-2015149311	A1	10/2015	WO	WO-2015192377	A1	12/2015
WO	WO-2015149330	A1	10/2015	WO	WO-2015193456	A1	12/2015
WO	WO-2015149332	A1	10/2015	WO	WO-2015196331	A1	12/2015
WO	WO-2015149338	A1	10/2015	WO	WO-2015196332	A1	12/2015
WO	WO-2015149368	A1	10/2015	WO	WO-2015196357	A1	12/2015
WO	WO-2015149403	A1	10/2015	WO	WO-2015196367	A1	12/2015
WO	WO-2015149406	A1	10/2015	WO	WO-2015196395	A1	12/2015
WO	WO-2015150068	A1	10/2015	WO	WO-2015196463	A1	12/2015
WO	WO-2015154309	A1	10/2015	WO	WO-2015148649	A3	1/2016
WO	WO-2015154619	A1	10/2015	WO	WO-2016000113	A1	1/2016
WO	WO-2015157891	A1	10/2015	WO	WO-2016000130	A1	1/2016
WO	WO-2015157893	A1	10/2015	WO	WO-2016000135	A1	1/2016
WO	WO-2015157900	A1	10/2015	WO	WO-2016000136	A1	1/2016
WO	WO-2015157901	A1	10/2015	WO	WO-2016000139	A1	1/2016
WO	WO-2015157928	A1	10/2015	WO	WO-2016000206	A1	1/2016
WO	WO-2015158522	A1	10/2015	WO	WO-2016000207	A1	1/2016
WO	WO-2015158548	A1	10/2015	WO	WO-2016000214	A1	1/2016
WO	WO-2015161406	A1	10/2015	WO	WO-2016000232	A1	1/2016
				WO	WO-2016000233	A1	1/2016
				WO	WO-2016000305	A1	1/2016
				WO	WO-2016008067	A1	1/2016
				WO	WO-2016008096	A1	1/2016



(56)

## References Cited

## FOREIGN PATENT DOCUMENTS

WO	WO-2016008217	A1	1/2016	WO	WO-2016063775	A1	4/2016
WO	WO-2016009202	A1	1/2016	WO	WO-2016065520	A1	5/2016
WO	WO-2016011573	A1	1/2016	WO	WO-2016065521	A1	5/2016
WO	WO-2016012769	A1	1/2016	WO	WO-2016065532	A1	5/2016
WO	WO-2016015196	A1	2/2016	WO	WO-2016065533	A1	5/2016
WO	WO-2016015245	A1	2/2016	WO	WO-2016065596	A1	5/2016
WO	WO-2016015246	A1	2/2016	WO	WO-2016065598	A1	5/2016
WO	WO-2016015247	A1	2/2016	WO	WO-2016065599	A1	5/2016
WO	WO-2016015264	A1	2/2016	WO	WO-2016065605	A1	5/2016
WO	WO-2016015712	A1	2/2016	WO	WO-2016065606	A1	5/2016
WO	WO-2016019353	A1	2/2016	WO	WO-2016065607	A1	5/2016
WO	WO-2016019508	A1	2/2016	WO	WO-2016070553	A1	5/2016
WO	WO-2016019550	A1	2/2016	WO	WO-2016071027	A1	5/2016
WO	WO-2016019573	A1	2/2016	WO	WO-2016071705	A1	5/2016
WO	WO-2016020675	A1	2/2016	WO	WO-2016071706	A1	5/2016
WO	WO-2016023173	A1	2/2016	WO	WO-2016074228	A1	5/2016
WO	WO-2016023176	A1	2/2016	WO	WO-2016074229	A1	5/2016
WO	WO-2016023177	A1	2/2016	WO	WO-2016074230	A1	5/2016
WO	WO-2016023181	A1	2/2016	WO	WO-2016074234	A1	5/2016
WO	WO-2016023182	A1	2/2016	WO	WO-2016074237	A1	5/2016
WO	WO-2016023183	A1	2/2016	WO	WO-2016076178	A1	5/2016
WO	WO-2016023212	A1	2/2016	WO	WO-2016079001	A1	5/2016
WO	WO-2016023651	A1	2/2016	WO	WO-2016079151	A1	5/2016
WO	WO-2016023824	A1	2/2016	WO	WO-2016079152	A1	5/2016
WO	WO-2016023965	A1	2/2016	WO	WO-2016079155	A1	5/2016
WO	WO-2016026104	A1	2/2016	WO	WO-2016079468	A1	5/2016
WO	WO-2016026105	A1	2/2016	WO	WO-2016079533	A1	5/2016
WO	WO-2016026156	A1	2/2016	WO	WO-2016079729	A1	5/2016
WO	WO-2016026811	A1	2/2016	WO	WO-2016058992	A3	6/2016
WO	WO-2016028544	A1	2/2016	WO	WO-2016059003	A3	6/2016
WO	WO-2016029344	A1	3/2016	WO	WO-2016082074	A1	6/2016
WO	WO-2016029382	A1	3/2016	WO	WO-2016082103	A1	6/2016
WO	WO-2016029386	A1	3/2016	WO	WO-2016082116	A1	6/2016
WO	WO-2016029389	A1	3/2016	WO	WO-2016082136	A1	6/2016
WO	WO-2016029429	A1	3/2016	WO	WO-2016082158	A1	6/2016
WO	WO-2016029464	A1	3/2016	WO	WO-2016082179	A1	6/2016
WO	WO-2016029468	A1	3/2016	WO	WO-2016082180	A1	6/2016
WO	WO-2016029470	A1	3/2016	WO	WO-2016082183	A1	6/2016
WO	WO-2016029473	A1	3/2016	WO	WO-2016082217	A1	6/2016
WO	WO-2016029567	A1	3/2016	WO	WO-2016082232	A1	6/2016
WO	WO-2016030661	A1	3/2016	WO	WO-2016082479	A1	6/2016
WO	WO-2016033721	A1	3/2016	WO	WO-2016086382	A1	6/2016
WO	WO-2016033734	A1	3/2016	WO	WO-2016090426	A1	6/2016
WO	WO-2016033783	A1	3/2016	WO	WO-2016090531	A1	6/2016
WO	WO-2016033817	A1	3/2016	WO	WO-2016090533	A1	6/2016
WO	WO-2016034100	A1	3/2016	WO	WO-2016090593	A1	6/2016
WO	WO-2016038029	A1	3/2016	WO	WO-2016090601	A1	6/2016
WO	WO-2016040575	A1	3/2016	WO	WO-2016090602	A1	6/2016
WO	WO-2016041114	A1	3/2016	WO	WO-2016090962	A1	6/2016
WO	WO-2016041140	A1	3/2016	WO	WO-2016092259	A1	6/2016
WO	WO-2016041141	A1	3/2016	WO	WO-2016095101	A1	6/2016
WO	WO-2016041207	A1	3/2016	WO	WO-2016095206	A1	6/2016
WO	WO-2016041209	A1	3/2016	WO	WO-2016095220	A1	6/2016
WO	WO-2016045058	A1	3/2016	WO	WO-2016095234	A1	6/2016
WO	WO-2016046116	A1	3/2016	WO	WO-2016095297	A1	6/2016
WO	WO-2015192834	A3	4/2016	WO	WO-2016096337	A1	6/2016
WO	WO-2016049822	A1	4/2016	WO	WO-2016096482	A1	6/2016
WO	WO-2016049823	A1	4/2016	WO	WO-2016096497	A1	6/2016
WO	WO-2016049855	A1	4/2016	WO	WO-2016096733	A1	6/2016
WO	WO-2016049863	A1	4/2016	WO	WO-2016096762	A1	6/2016
WO	WO-2016050246	A1	4/2016	WO	WO-2016096762	A1	6/2016
WO	WO-2016050247	A1	4/2016	WO	WO-2016099045	A1	6/2016
WO	WO-2016054793	A1	4/2016	WO	WO-2016099276	A1	6/2016
WO	WO-2016055653	A1	4/2016	WO	WO-2016101141	A1	6/2016
WO	WO-2016058139	A1	4/2016	WO	WO-2016101142	A1	6/2016
WO	WO-2016058187	A1	4/2016	WO	WO-2016101143	A1	6/2016
WO	WO-2016058189	A1	4/2016	WO	WO-2016101144	A1	6/2016
WO	WO-2016059000	A1	4/2016	WO	WO-2016101150	A1	6/2016
WO	WO-2016060576	A1	4/2016	WO	WO-2016101183	A1	6/2016
WO	WO-2016061729	A1	4/2016	WO	WO-2016101200	A1	6/2016
WO	WO-2016061730	A1	4/2016	WO	WO-2016101202	A1	6/2016
WO	WO-2016061822	A1	4/2016	WO	WO-2016101203	A1	6/2016
WO	WO-2016061859	A1	4/2016	WO	WO-2016101248	A1	6/2016
WO	WO-2016062168	A1	4/2016	WO	WO-2016103202	A1	6/2016
WO	WO-2016062777	A1	4/2016	WO	WO-2016105191	A1	6/2016
				WO	WO-2016036236	A3	7/2016
				WO	WO-2016106476	A1	7/2016
				WO	WO-2016106483	A1	7/2016
				WO	WO-2016106493	A1	7/2016
				WO	WO-2016106495	A1	7/2016



(56)

## References Cited

## FOREIGN PATENT DOCUMENTS

WO	WO-2016106499	A1	7/2016	WO	WO-2016138689	A1	9/2016
WO	WO-2016106500	A1	7/2016	WO	WO-2016141508	A1	9/2016
WO	WO-2016106512	A1	7/2016	WO	WO-2016141555	A1	9/2016
WO	WO-2016108693	A1	7/2016	WO	WO-2016141556	A1	9/2016
WO	WO-2016108694	A1	7/2016	WO	WO-2016141581	A1	9/2016
WO	WO-2016109929	A1	7/2016	WO	WO-2016141592	A1	9/2016
WO	WO-2016109930	A1	7/2016	WO	WO-2016141593	A1	9/2016
WO	WO-2016109931	A1	7/2016	WO	WO-2016145611	A1	9/2016
WO	WO-2016109932	A1	7/2016	WO	WO-2016145612	A1	9/2016
WO	WO-2016109933	A1	7/2016	WO	WO-2016145613	A1	9/2016
WO	WO-2016109942	A1	7/2016	WO	WO-2016145634	A1	9/2016
WO	WO-2016109964	A1	7/2016	WO	WO-2016145656	A1	9/2016
WO	WO-2016109965	A1	7/2016	WO	WO-2016145663	A1	9/2016
WO	WO-2016110522	A1	7/2016	WO	WO-2016149896	A1	9/2016
WO	WO-2016112491	A1	7/2016	WO	WO-2016149932	A1	9/2016
WO	WO-2016112493	A1	7/2016	WO	WO-2016149942	A1	9/2016
WO	WO-2016112533	A1	7/2016	WO	WO-2016150019	A1	9/2016
WO	WO-2016112534	A1	7/2016	WO	WO-2016150979	A1	9/2016
WO	WO-2016112541	A1	7/2016	WO	WO-2016154792	A1	10/2016
WO	WO-2016112542	A1	7/2016	WO	WO-2016154797	A1	10/2016
WO	WO-2016112561	A1	7/2016	WO	WO-2016154798	A1	10/2016
WO	WO-2016112579	A1	7/2016	WO	WO-2016154815	A1	10/2016
WO	WO-2016115689	A1	7/2016	WO	WO-2016154895	A1	10/2016
WO	WO-2016115691	A1	7/2016	WO	WO-2016154896	A1	10/2016
WO	WO-2016115701	A1	7/2016	WO	WO-2016154897	A1	10/2016
WO	WO-2016115715	A1	7/2016	WO	WO-2016154900	A1	10/2016
WO	WO-2016116754	A1	7/2016	WO	WO-2016154994	A1	10/2016
WO	WO-2016116755	A1	7/2016	WO	WO-2016155003	A1	10/2016
WO	WO-2016118005	A1	7/2016	WO	WO-2016155103	A1	10/2016
WO	WO-2016119098	A1	8/2016	WO	WO-2016155104	A1	10/2016
WO	WO-2016119099	A1	8/2016	WO	WO-2016155105	A1	10/2016
WO	WO-2016119101	A1	8/2016	WO	WO-2016155316	A1	10/2016
WO	WO-2016119119	A1	8/2016	WO	WO-2016156103	A1	10/2016
WO	WO-2016119121	A1	8/2016	WO	WO-2016156217	A1	10/2016
WO	WO-2016119144	A1	8/2016	WO	WO-2016156413	A1	10/2016
WO	WO-2016119145	A1	8/2016	WO	WO-2016161554	A1	10/2016
WO	WO-2016119163	A1	8/2016	WO	WO-2016161673	A1	10/2016
WO	WO-2016119167	A1	8/2016	WO	WO-2016162446	A1	10/2016
WO	WO-2016119170	A1	8/2016	WO	WO-2016162492	A1	10/2016
WO	WO-2016119225	A1	8/2016	WO	WO-2016165055	A1	10/2016
WO	WO-2016119248	A1	8/2016	WO	WO-2016165057	A1	10/2016
WO	WO-2016119273	A1	8/2016	WO	WO-2016165063	A1	10/2016
WO	WO-2016119496	A1	8/2016	WO	WO-2016165125	A1	10/2016
WO	WO-2016122417	A1	8/2016	WO	WO-2016166049	A1	10/2016
WO	WO-2016123763	A1	8/2016	WO	WO-2016166456	A1	10/2016
WO	WO-2016123764	A1	8/2016	WO	WO-2016166661	A1	10/2016
WO	WO-2016123770	A1	8/2016	WO	WO-2016166670	A1	10/2016
WO	WO-2016123779	A1	8/2016	WO	WO-2016168274	A1	10/2016
WO	WO-2016123780	A1	8/2016	WO	WO-2016168986	A1	10/2016
WO	WO-2016123781	A1	8/2016	WO	WO-2016169019	A1	10/2016
WO	WO-2016124017	A1	8/2016	WO	WO-2016169052	A1	10/2016
WO	WO-2016124019	A1	8/2016	WO	WO-2016169063	A1	10/2016
WO	WO-2016124695	A1	8/2016	WO	WO-2016169669	A1	10/2016
WO	WO-2016124740	A1	8/2016	WO	WO-2016169796	A1	10/2016
WO	WO-2016124741	A1	8/2016	WO	WO-2016169797	A1	10/2016
WO	WO-2016127287	A1	8/2016	WO	WO-2016172802	A1	11/2016
WO	WO-2016127293	A1	8/2016	WO	WO-2016172821	A1	11/2016
WO	WO-2016127327	A1	8/2016	WO	WO-2016172843	A1	11/2016
WO	WO-2016127360	A1	8/2016	WO	WO-2016172847	A1	11/2016
WO	WO-2016127361	A1	8/2016	WO	WO-2016172867	A1	11/2016
WO	WO-2016127389	A1	8/2016	WO	WO-2016172898	A1	11/2016
WO	WO-2016127390	A1	8/2016	WO	WO-2016172907	A1	11/2016
WO	WO-2016127396	A1	8/2016	WO	WO-2016172908	A1	11/2016
WO	WO-2016127397	A1	8/2016	WO	WO-2016172909	A1	11/2016
WO	WO-2016127401	A1	8/2016	WO	WO-2016172954	A1	11/2016
WO	WO-2016127406	A1	8/2016	WO	WO-2016174179	A1	11/2016
WO	WO-2016127468	A1	8/2016	WO	WO-2016176800	A1	11/2016
WO	WO-2016127839	A1	8/2016	WO	WO-2016177604	A1	11/2016
WO	WO-2016128562	A1	8/2016	WO	WO-2016179356	A1	11/2016
WO	WO-2016131755	A1	8/2016	WO	WO-2016179664	A1	11/2016
WO	WO-2016132026	A1	8/2016	WO	WO-2016179776	A1	11/2016
WO	WO-2016134544	A1	9/2016	WO	WO-2016179828	A1	11/2016
WO	WO-2016135503	A1	9/2016	WO	WO-2016183724	A1	11/2016
WO	WO-2016138608	A1	9/2016	WO	WO-2016184247	A1	11/2016
WO	WO-2016138665	A1	9/2016	WO	WO-2016184824	A1	11/2016
				WO	WO-2016171997	A3	12/2016
				WO	WO-2016187803	A1	12/2016
				WO	WO-2016187943	A1	12/2016
				WO	WO-2016188140	A1	12/2016



(56)

## References Cited

## FOREIGN PATENT DOCUMENTS

WO	WO-2016188141	A1	12/2016	WO	WO-2017031681	A1	3/2017
WO	WO-2016188142	A1	12/2016	WO	WO-2017033007	A1	3/2017
WO	WO-2016188967	A1	12/2016	WO	WO-2017033021	A1	3/2017
WO	WO-2016189086	A1	12/2016	WO	WO-2017033132	A1	3/2017
WO	WO-2016191946	A1	12/2016	WO	WO-2017035720	A1	3/2017
WO	WO-2016193336	A1	12/2016	WO	WO-2017036818	A1	3/2017
WO	WO-2016193365	A1	12/2016	WO	WO-2017036819	A1	3/2017
WO	WO-2016193743	A1	12/2016	WO	WO-2017036828	A1	3/2017
WO	WO-2016197485	A1	12/2016	WO	WO-2017036829	A1	3/2017
WO	WO-2016197658	A1	12/2016	WO	WO-2017036865	A1	3/2017
WO	WO-2016198417	A1	12/2016	WO	WO-2017036879	A1	3/2017
WO	WO-2016198459	A1	12/2016	WO	WO-2017041251	A1	3/2017
WO	WO-2016198879	A1	12/2016	WO	WO-2017042081	A1	3/2017
WO	WO-2016199062	A1	12/2016	WO	WO-2017045132	A1	3/2017
WO	WO-2016199065	A1	12/2016	WO	WO-2017045897	A1	3/2017
WO	WO-2016199066	A1	12/2016	WO	WO-2017045898	A1	3/2017
WO	WO-2016200252	A1	12/2016	WO	WO-2017045899	A1	3/2017
WO	WO-2016200253	A1	12/2016	WO	WO-2017046247	A1	3/2017
WO	WO-2016200255	A1	12/2016	WO	WO-2017046334	A1	3/2017
WO	WO-2016200259	A1	12/2016	WO	WO-2017046363	A1	3/2017
WO	WO-2016200382	A1	12/2016	WO	WO-2017046566	A1	3/2017
WO	WO-2016201602	A1	12/2016	WO	WO-2017049653	A1	3/2017
WO	WO-2016201606	A1	12/2016	WO	WO-2017049654	A1	3/2017
WO	WO-2016201911	A1	12/2016	WO	WO-2017051150	A1	3/2017
WO	WO-2016202028	A1	12/2016	WO	WO-2017051174	A1	3/2017
WO	WO-2016202033	A1	12/2016	WO	WO-2017051348	A1	3/2017
WO	WO-2016202301	A1	12/2016	WO	WO-2017051349	A1	3/2017
WO	WO-2016202302	A1	12/2016	WO	WO-2017046593	A3	4/2017
WO	WO-2016202303	A1	12/2016	WO	WO-2017054424	A1	4/2017
WO	WO-2016202304	A1	12/2016	WO	WO-2017054627	A1	4/2017
WO	WO-2016207357	A1	12/2016	WO	WO-2017054634	A1	4/2017
WO	WO-2016208757	A1	12/2016	WO	WO-2017055564	A1	4/2017
WO	WO-2016208760	A1	12/2016	WO	WO-2017055584	A1	4/2017
WO	WO-2016193705	A3	1/2017	WO	WO-2017055793	A1	4/2017
WO	WO-2017000239	A1	1/2017	WO	WO-2017055795	A1	4/2017
WO	WO-2017001270	A1	1/2017	WO	WO-2017055799	A1	4/2017
WO	WO-2017001817	A1	1/2017	WO	WO-2017055801	A1	4/2017
WO	WO-2017001818	A1	1/2017	WO	WO-2017055802	A1	4/2017
WO	WO-2017001819	A1	1/2017	WO	WO-2017055803	A1	4/2017
WO	WO-2017001820	A1	1/2017	WO	WO-2017055866	A1	4/2017
WO	WO-2017005835	A1	1/2017	WO	WO-2017056103	A1	4/2017
WO	WO-2017007252	A1	1/2017	WO	WO-2017057286	A1	4/2017
WO	WO-2017008616	A1	1/2017	WO	WO-2017059571	A1	4/2017
WO	WO-2017009002	A1	1/2017	WO	WO-2017060279	A1	4/2017
WO	WO-2017011419	A1	1/2017	WO	WO-2017063256	A1	4/2017
WO	WO-2017012099	A1	1/2017	WO	WO-2017063535	A1	4/2017
WO	WO-2017012105	A1	1/2017	WO	WO-2017064051	A1	4/2017
WO	WO-2017012257	A1	1/2017	WO	WO-2017064322	A1	4/2017
WO	WO-2017012335	A1	1/2017	WO	WO-2017064323	A1	4/2017
WO	WO-2016172921	A8	2/2017	WO	WO-2017064324	A1	4/2017
WO	WO-2016178098	A3	2/2017	WO	WO-2017064487	A1	4/2017
WO	WO-2017015791	A1	2/2017	WO	WO-2017066938	A1	4/2017
WO	WO-2017015794	A1	2/2017	WO	WO-2017066955	A1	4/2017
WO	WO-2017015832	A1	2/2017	WO	WO-2017067066	A1	4/2017
WO	WO-2017015859	A1	2/2017	WO	WO-2017067326	A1	4/2017
WO	WO-2017016323	A1	2/2017	WO	WO-2017068098	A1	4/2017
WO	WO-2017017970	A1	2/2017	WO	WO-2017068099	A1	4/2017
WO	WO-2017020220	A1	2/2017	WO	WO-2017068100	A1	4/2017
WO	WO-2017020221	A1	2/2017	WO	WO-2016096745	A9	5/2017
WO	WO-2017020275	A1	2/2017	WO	WO-2016173568	A3	5/2017
WO	WO-2017020290	A1	2/2017	WO	WO-2016198026	A3	5/2017
WO	WO-2017023589	A1	2/2017	WO	WO-2017051350	A3	5/2017
WO	WO-2017024477	A1	2/2017	WO	WO-2017070871	A1	5/2017
WO	WO-2017024478	A1	2/2017	WO	WO-2017071297	A1	5/2017
WO	WO-2017024799	A1	2/2017	WO	WO-2017071298	A1	5/2017
WO	WO-2017024926	A1	2/2017	WO	WO-2017072239	A1	5/2017
WO	WO-2017025383	A1	2/2017	WO	WO-2017072277	A1	5/2017
WO	WO-2017028167	A1	2/2017	WO	WO-2017072284	A1	5/2017
WO	WO-2017028295	A1	2/2017	WO	WO-2017075753	A1	5/2017
WO	WO-2017029268	A1	2/2017	WO	WO-2017075759	A1	5/2017
WO	WO-2017029269	A1	2/2017	WO	WO-2017075827	A1	5/2017
WO	WO-2017029270	A1	2/2017	WO	WO-2017075883	A1	5/2017
WO	WO-2017021536	A3	3/2017	WO	WO-2017075975	A1	5/2017
WO	WO-2017031662	A1	3/2017	WO	WO-2017076247	A1	5/2017
WO	WO-2017031678	A1	3/2017	WO	WO-2017076590	A1	5/2017
				WO	WO-2017081480	A1	5/2017
				WO	WO-2017082728	A1	5/2017
				WO	WO-2017084107	A1	5/2017
				WO	WO-2017084488	A1	5/2017



(56)

## References Cited

## FOREIGN PATENT DOCUMENTS

WO WO-2017084489 A1 5/2017  
 WO WO-2017084818 A1 5/2017  
 WO WO-2017084848 A1 5/2017  
 WO WO-2017084849 A1 5/2017  
 WO WO-2017084920 A2 5/2017  
 WO WO-2017085240 A1 5/2017  
 WO WO-2017085242 A1 5/2017  
 WO WO-2017081176 A3 6/2017  
 WO WO-2017088660 A1 6/2017  
 WO WO-2017089931 A1 6/2017  
 WO WO-2017091926 A1 6/2017  
 WO WO-2017092144 A1 6/2017  
 WO WO-2017093452 A1 6/2017  
 WO WO-2017093535 A1 6/2017  
 WO WO-2017096512 A1 6/2017  
 WO WO-2017096971 A1 6/2017  
 WO WO-2017096988 A1 6/2017  
 WO WO-2017097172 A1 6/2017  
 WO WO-2017097173 A1 6/2017  
 WO WO-2017097821 A1 6/2017  
 WO WO-2017101030 A1 6/2017  
 WO WO-2017101058 A1 6/2017  
 WO WO-2017101705 A1 6/2017  
 WO WO-2017102633 A1 6/2017  
 WO WO-2017102686 A1 6/2017  
 WO WO-2017102969 A1 6/2017  
 WO WO-2017107546 A1 6/2017  
 WO WO-2017108268 A1 6/2017  
 WO WO-2017108392 A1 6/2017  
 WO WO-2017108394 A1 6/2017  
 WO WO-2017108429 A1 6/2017  
 WO WO-2017109448 A2 6/2017  
 WO WO-2017109868 A1 6/2017  
 WO WO-2017110713 A1 6/2017  
 WO WO-2017036426 A3 7/2017  
 WO WO-2017113106 A1 7/2017  
 WO WO-2017113513 A1 7/2017  
 WO WO-2017113845 A1 7/2017  
 WO WO-2017114389 A1 7/2017  
 WO WO-2017117725 A1 7/2017  
 WO WO-2017117742 A1 7/2017  
 WO WO-2017118135 A1 7/2017  
 WO WO-2017118138 A1 7/2017  
 WO WO-2017118347 A1 7/2017  
 WO WO-2017121156 A1 7/2017  
 WO WO-2017121253 A1 7/2017  
 WO WO-2017121296 A1 7/2017  
 WO WO-2017121546 A1 7/2017  
 WO WO-2017121979 A1 7/2017  
 WO WO-2017122196 A1 7/2017  
 WO WO-2017124419 A1 7/2017  
 WO WO-2017124662 A1 7/2017  
 WO WO-2017124957 A1 7/2017  
 WO WO-2017128038 A1 8/2017  
 WO WO-2017133056 A1 8/2017  
 WO WO-2017137138 A1 8/2017  
 WO WO-2017137554 A1 8/2017  
 WO WO-2017139963 A1 8/2017  
 WO WO-2017141017 A1 8/2017  
 WO WO-2017141018 A1 8/2017  
 WO WO-2017141358 A1 8/2017  
 WO WO-2017143494 A1 8/2017  
 WO WO-2017143495 A1 8/2017  
 WO WO-2017143515 A1 8/2017  
 WO WO-2017143865 A1 8/2017  
 WO WO-2017143953 A1 8/2017  
 WO WO-2017144400 A1 8/2017  
 WO WO-2017144861 A1 8/2017  
 WO WO-2017149288 A1 9/2017  
 WO WO-2017152481 A1 9/2017  
 WO WO-2017153051 A1 9/2017  
 WO WO-2017153270 A1 9/2017  
 WO WO-2017156694 A1 9/2017  
 WO WO-2017156695 A1 9/2017  
 WO WO-2017156696 A1 9/2017

WO WO-2017156733 A1 9/2017  
 WO WO-2017156743 A1 9/2017  
 WO WO-2017161715 A1 9/2017  
 WO WO-2017161725 A1 9/2017  
 WO WO-2017163044 A1 9/2017  
 WO WO-2017163045 A1 9/2017  
 WO WO-2017163046 A1 9/2017  
 WO WO-2017163047 A1 9/2017  
 WO WO-2017163050 A1 9/2017  
 WO WO-2017163051 A1 9/2017  
 WO WO-2017163052 A1 9/2017  
 WO WO-2017164474 A1 9/2017  
 WO WO-2017166263 A1 10/2017  
 WO WO-2017166334 A1 10/2017  
 WO WO-2017167169 A1 10/2017  
 WO WO-2017167513 A1 10/2017  
 WO WO-2017173669 A1 10/2017  
 WO WO-2017173947 A1 10/2017  
 WO WO-2017173951 A1 10/2017  
 WO WO-2017174754 A1 10/2017  
 WO WO-2017175166 A1 10/2017  
 WO WO-2017176111 A1 10/2017  
 WO WO-2017176113 A1 10/2017  
 WO WO-2017177897 A1 10/2017  
 WO WO-2018102696 A1 6/2018  
 WO WO-2018102699 A1 6/2018  
 WO WO-2018102701 A1 6/2018  
 WO WO-2018102703 A1 6/2018

## OTHER PUBLICATIONS

Review: the Pax 2. by Chris Roberts. dated Mar. 10, 2015. found online [Nov. 20, 2020] <http://sfevergreen.com/review-the-pax-2-solution-to-all-of-lifes-unknown-problems/>.\*

KandyPens Rubi vs Pax Era vs Juul. By TVG Team. dated Dec. 10, 2019. found online [Nov. 20, 2020] <https://thevape.guide/kandypens-rubi-vs-pax-era-vs-juul/>.\*

“Commission Regulation (EC) No. 1275/2008,” Official Journal of the European Union, Dec. 17, 2008.

“Guideline Accompanying Commission Regulation (EC) No. 1275/2008,” Official Journal of the European Union, Oct. 2009.

“Lighter.” Merriam-Webster Online Dictionary. 2009. Merriam-Webster Online. Jun. 8, 2009 [<http://www.merriam-webster.com/dictionary/lighter>].

“Pax Era Vape Sesh and Review.” Time 6:33, *Youtube*, 2018. Web. <https://www.youtube.com/watch?v=aa1XSd16u78>.

AMB. Manual:TranX160/Rev.10-06. published 2004-2006.

Baker et al., “The pyrolysis of tobacco ingredients,” *J. Anal. Appl. Pyrolysis*, vol. 71, pp. 223-311 (2004).

Bombick, et al. Chemical and biological studies of a new cigarette that primarily heats tobacco. Part 2. In vitro toxicology of mainstream smoke condensate. *Food and Chemical Toxicology*. 1997; 36:183-190.

Bombick, et al. Chemical and biological studies of a new cigarette that primarily heats tobacco. Part 3. In vitro toxicity of whole smoke. *Food and Chemical Toxicology*. 1998; 36:191-197.

Borgerding, et al. Chemical and biological studies of a new cigarette that primarily heats tobacco. Part 1. Chemical composition of mainstream smoke. *Food and Chemical Toxicology*. 1997; 36:169-182.

Breland, Alison, et al. “Electronic cigarettes: what are they and what do they do?.” *Annals of the New York Academy of Sciences* 1394.1 (2017): 5-30.

Brown, Christopher J., et al., “Electronic cigarettes: product characterisation and design considerations.” *Tobacco control* 23.suppl 2 (2014): ii4-ii10.

Bullen, et al., “Effect of an electronic nicotine delivery device (e cigarette) on desire to smoke and withdrawal, user preferences and nicotine delivery: randomized cross-over trial,” *Tobacco Control*, 19(2), pp. 98-103. Apr. 2010.

Burch, et al., “Effect of pH on nicotine absorption and side effects produced by aerosolized nicotine,” *Journal of Aerosol Medicine: Deposition, Clearance, and Effects in the Lung*, 6(1), pp. 45-52. 1993.



(56)

## References Cited

## OTHER PUBLICATIONS

- Capponnetto, et al., "Successful smoking cessation with cigarettes in smokers with a documented history of recurring relapses: a case series," *Journal of Medical Case Reports*; 5(1), 6 pages. 2011.
- Davis & Nielsen, "Marketing, Processing and Storage: Green Leaf Threshing and Redrying Tobacco," *Tobacco Production, Chemistry and Technology*, (1999) Section 10B, pp. 330-333, Bill Ward, Expert Leaf Tobacco Company, Wilson, North Carolina, USA.
- E-Cigarette Forum; pg-gv-peg (discussion/posting); retrieved from the Internet: <https://e-cigarette-forum.com/forum/threads/pg-gv-peg-177551>; 7 pgs.; Apr. 8, 2011.
- ECF; Any interest in determining nicotine—by DVAP; (<https://www.e-cigarette-forum.com/forum/threads/any-interest-in-determining-nicotine-by-dvap.35922/>); blog posts dated: 2009; 8 pgs.; print/retrieval date: Jul. 31, 2014.
- Electronic Vaporization Device with Cartridge | JUUL Pod | JUUL Vapor, Posted Jun. 3, 2015, © 2015, Juulvapor.com, retrieved Nov. 24, 2015, <https://www.juulvapor.com/shopjuul/>.
- Electronic Vaporization Device/ Gizmodo Pax 2 Vaporizer/ Gizmodo; retrieved from <http://gizmodo.com/pax-2-vaporizer-reviews-its-like-smoking-in-the-future-1718310779>; posted Jul. 23, 2015, retrieved Oct. 17, 2016.
- Engadget. *Juul is the e-cig that will finally stop me from smoking (I hope)*. [online], published on Jun. 3, 2015. Available at: <https://www.engadget.com/2015/06/03/pax-labs-juul-ecigarette/#>.
- Farsalinos, et al., "Electronic cigarettes do not damage the heart," *European Society of Cardiology*, 4 pages, (<http://www.escardio.org/The-ESC/Press-Office/Press-releases/Electronic-cigarettes-do-not-damage-the-heart>). Aug. 25, 2012.
- Farsalinos, Konstantinos E., et al. "Protocol proposal for, and evaluation of, consistency in nicotine delivery from the liquid to the aerosol of electronic cigarettes atomizers: regulatory implications." *Addiction* 111.6 (2016): 1069-1076.
- Farsalinos, Konstantinos E., et al. *Analytical Assessment of e-Cigarettes: From Contents to Chemical and Particle Exposure Profiles*. pp. 1-35. Elsevier, 2016.
- FC Vaporizer Review Forum; Pax Vaporizer by Ploom; retrieved from : <http://fuckcombustion.com/threads/pax-vaporizer-by-ploom.6223/>; pp. 2 & 11 (2 pgs.); retrieval date: Nov. 16, 2015.
- Flouris, et al., "Acute impact of active and passive electronic cigarette smoking on serum cotinine and lung function," *Inhal. Toxicol.*, 25(2), pp. 91-101. Feb. 2013.
- Food & Drug Administration; Warning letter to the Compounding Pharmacy, retrieved Oct. 10, 2014 from <http://www.fda.gov/ICECI/EnforcementActions/WarningLetters/2002/ucm144843.htm>, 3 pages. Apr. 9, 2002.
- Geiss, Otmar, Ivana Bianchi, and Josefa Barrero-Moreno. "Correlation of volatile carbonyl yields emitted by e-cigarettes with the temperature of the heating coil and the perceived sensorial quality of the generated vapours." *International journal of hygiene and environmental health* 219.3 (2016): 268-277.
- Gillman, I. G., et al. "Effect of variable power levels on the yield of total aerosol mass and formation of aldehydes in e-cigarette aerosols." *Regulatory Toxicology and Pharmacology* 75 (2016): 58-65.
- Giorgio, Agostino. "E-Cig Digital Design for the Smoke Control Optimization." *International Journal of Applied Engineering Research* 11.8 (2016): 6018-6023.
- Goniewicz, et al., "Nicotine levels in electronic cigarettes," *Nicotine Tobacco Research*, 15(1), pp. 158-166, Jan. 2013.
- Gregory, Andrew, "E-cigarettes to go on prescription under move to class them as medicines," *Mirror*, Jun. 12, 2013. <http://www.mirror.co.uk/news/uk-news/e-cigarettes-go-prescription-under-move-1949018>.
- Grotenhermen, et al., Developing science-based per se limits for driving under the influence of cannabis (DUIC): findings and recommendations by an expert panel; retrieved Feb. 9, 2017 from (<http://www.canorml.org/healthfacts/DUICreport.2005.pdf>); Sep. 2005.
- Harvest Vapor, American Blend Tobacco (product info), retrieved from the internet (<http://harvestvapor.com/>), 2 pages. Oct. 10, 2014.
- Hurt, et al., "Treating tobacco dependence in a medical setting," *CA: A Cancer Journal for Clinicians*, 59(5), pp. 314-326. Sep. 2009.
- Ijoy. "Who we are." *Ijoy Diamond PD270 Kit*, Date Accessed Feb. 20, 2018. [www.ijoycig.com/product/item-473.html](http://www.ijoycig.com/product/item-473.html).
- Inchem; Benzoic Acid; JECFA Evaluation Summary; retrieved Oct. 10, 2014 from [http://www.inchem.org/documents/jecfa/feceval/jec\\_184.htm](http://www.inchem.org/documents/jecfa/feceval/jec_184.htm), 2 pages. May 28, 2005.
- Inchem; Levulinic Acid; JECFA Evaluation Summary; retrieved Oct. 10, 2014 from [http://www.inchem.org/documents/jecfa/feceval/jec\\_1266.htm](http://www.inchem.org/documents/jecfa/feceval/jec_1266.htm), 2 pages. Mar. 10, 2003.
- Inchem; Pyruvic Acid; JECFA Evaluation Summary; retrieved Oct. 10, 2014 from [http://www.inchem.org/documents/jecfa/feceval/jec\\_2072.htm](http://www.inchem.org/documents/jecfa/feceval/jec_2072.htm), 2 pages. Jan. 29, 2003.
- Inchem; Sorbic Acid; JECFA Evaluation Summary; retrieved Oct. 10, 2014 from [http://www.inchem.org/documents/jecfa/feceval/jec\\_2181.htm](http://www.inchem.org/documents/jecfa/feceval/jec_2181.htm), 2 pages. May 29, 2005.
- Ingebretsen et al., "Electronic Cigarette aerosol particle size distribution measurements", *Inhalation Toxicology*, 2012; 24 (14): 976-984.
- Kanger K1 Stabilized Wood DNA 75 Box Mod—KangerTech*. Date Accessed Feb. 20, 2018. <https://kangeronline.com/products/kanger-k1-stabilized-wood-dna-75-box-mod>.
- Kuo et al. Applications of Turbulent and Multiphase Combustion, Appendix D: Particle Size—U.S. Sieve Size and Tyler Screen Mesh Equivalents, 2012, p. 541-543.
- Marshall, John R., Shahram Lotfipour, and Bharath Chakravarthy. "Growing Trend of Alternative Tobacco Use Among the Nation's Youth: A New Generation of Addicts." *Western Journal of Emergency Medicine* 17.2 (2016): 139.
- McCann et al., "Detection of carcinogens as mutagens in the Salmonella/microsome test: Assay of 300 chemicals: discussion." *Proct. Nat. Acad. Sci, USA*, Mar. 1976, vol. 73 (3), 950-954.
- Melia Robinson, "The 'Apple of Vaping' Made an E-Cigarette for Marijuana—Here's What It's Like." *Business Insider*, Oct. 13, 2016. Web. <https://www.businessinsider.nl/pax-era-vape-pen-review-2016-10/>.
- Mylaps, "Rechargeable Transponder Battery Status and Charging Instructions," Sep. 9, 2010.
- Nicoli et al., Mammalian tumor xenografts induce neovascularization in Zebrafish embryos. *Cancer Research*, 67:2927-2931 (2007).
- PAX Labs, Inc.; JUUL product information © 2016; retrieved from <https://www.juulvapor.com/shop-juul/>; 6 pgs.; retrieved Mar. 9, 2016.
- Perfetti, "Structural study of nicotine salts," *Beitrage Zur Tabakforschung International, Contributions to Tobacco Research*, 12(2), pp. 43-54. Jun. 1983.
- Pierce, D. *This Might Just Be the First Great E-Cig*. {online} *Wired*, Published on Apr. 21, 2015. Available at: [https://www.wired.com/2015/04/pax-juul-ecig/?mbid=social\\_twitter](https://www.wired.com/2015/04/pax-juul-ecig/?mbid=social_twitter).
- Polosa, Riccardo, et al. "Effect of an electronic nicotine delivery device (e-Cigarette) on smoking reduction and cessation: a prospective 6-month pilot study." *BMC public health* 11.1 (2011): 786.
- Poynton, Simon, et al. "A novel hybrid tobacco product that delivers a tobacco flavour note with vapour aerosol (part 1): Product operation and preliminary aerosol chemistry assessment." *Food and Chemical Toxicology* (2017).
- Poynton, Simon, et al. "A novel hybrid tobacco product that delivers a tobacco flavour note with vapour aerosol (Part 1): product operation and preliminary aerosol chemistry assessment." *Food and Chemical Toxicology* 106 (2017): 522-532.
- Seeman, et al., "The form of nicotine in tobacco. Thermal transfer of nicotine and nicotine acid salts to nicotine in the gas phase," *J Aric Food Chem*, 47(12), pp. 5133-5145. Dec. 1999.
- Smok. *Pro Color—Smok® Innovation keeps changing the vaping experience!*, Date Accessed Feb. 20, 2018. [www.smoktech.com/kit/procolor](http://www.smoktech.com/kit/procolor).
- SRNT Subcommittee on Biochemical Verification, "Biochemical verification of tobacco use and cessation," *Nicotine & Tobacco Research* 4, pp. 149-159, 2002.
- Stanford, Judie. "PAX Era: The On-Demand Slim Extract Vaporizer Ready for Medical Use." *GearDiary*. Oct. 16, 2016. Web. <https://geardiary.com/2016/10/16/pax-era-the-on-demand-slim-extract-vaporizer-ready-for-medical-use/>.



(56)

**References Cited**

## OTHER PUBLICATIONS

Tarantola, Andrew. "The Pax 2 vaporizer makes its predecessor look half-Baked." Engadget, Jul. 14, 2016, [www.engadget.com/2015/04/20/pax-2-vaporizer-review/](http://www.engadget.com/2015/04/20/pax-2-vaporizer-review/). Accessed Sep. 5, 2017.

The Verge. *Startup behind the Lambo of vaporizers just launched an intelligent e-cigarette*. [online], published on Apr. 21, 2015. Available at: <https://www.theverge.com/2015/4/21/8458629/pax-labs-e-cigarette-juul>.

Torikai et al., "Effects of temperature, atmosphere and pH on the generation of smoke compounds during tobacco pyrolysis," *Food and Chemical Toxicology* 42 (2004) 1409-1417.

Vansickel, et al. "A clinical laboratory model for evaluating the acute effects of electronic cigarettes: Nicotine delivery profile and cardiovascular and subjective effects," *Cancer Epidemiology Biomarkers Prevention*, 19(9), pp. 1945-1953. Jul. 20, 2010.

Vansickel, et al., "Electronic cigarettes: effective nicotine delivery after acute administration," *Nicotine & Tobacco Research*, 15(1), pp. 267-270. Jan. 2013.

VapeWorld; Original PAX Vaporizers for Portable and Home Use; retrieved from: <https://www.vapeworld.com/pax-vaporizer-by-ploom?gclid=CPCi1PKojskCFUO6gQodPr>; 9 pgs.; retrieved Nov. 13, 2015.

Vapresso (Shenzhen Smoore Technology Limited). "Target Pro Vape Mod." *Vape Batteries & Mods | Target Pro Vape Mod |*

Vapresso, Date Accessed Feb. 20, 2018. [www.vapresso.com/vape-batteries-and-mods/target-pro-vape-mod](http://www.vapresso.com/vape-batteries-and-mods/target-pro-vape-mod).

Vapresso (Shenzhen Smoore Technology Limited). "Tarot Pro Vape Mod." *Vape Batteries & Mods | Tarot Pro Vape Mod 51 Vapresso*, Date Accessed Feb. 20, 2018. [www.vapresso.com/vape-batteries-and-mods/tarot-pro-vape-mod](http://www.vapresso.com/vape-batteries-and-mods/tarot-pro-vape-mod).

Wells. "Glycerin as a Constituent of Cosmetics and Toilet Preparations." *Journal of the Society of Cosmetic Chemists*, 1958; 9(1): 19-25.

Williams, Monique, and Prue Talbot. "Variability among electronic cigarettes in the pressure drop, airflow rate, and aerosol production." *Nicotine & Tobacco Research* 13.12 (2011).

Youtube, "Pax 2 Unboxing," retrieved from [www.youtube.com/watch?v=Vjccs8co3YY](http://www.youtube.com/watch?v=Vjccs8co3YY), posted Apr. 20, 2015.

YouTube; Firefly Vaporizer Review w/ Usage Tips by the Vape Critic; retrieved from the internet (<http://www.youtube.com/watch?v=1J38N0AV7w1>); published Dec. 10, 2013; download/ print date: Feb. 18, 2015.

Youtube; Pax by Ploom Vaporizer Review; posted Aug. 14, 2013, retrieved Sep. 8, 2016, <https://www.youtube.com/watch?v=Jm06zW3-cxQ>.

Zhang, et al., "In vitro partical size distributions in electronic and conventional cigarette aerosols suggest comparable deposition patterns," *Nicotine Tobacco Research*, 15(2), pp. 501-508. Feb. 2013.

\* cited by examiner



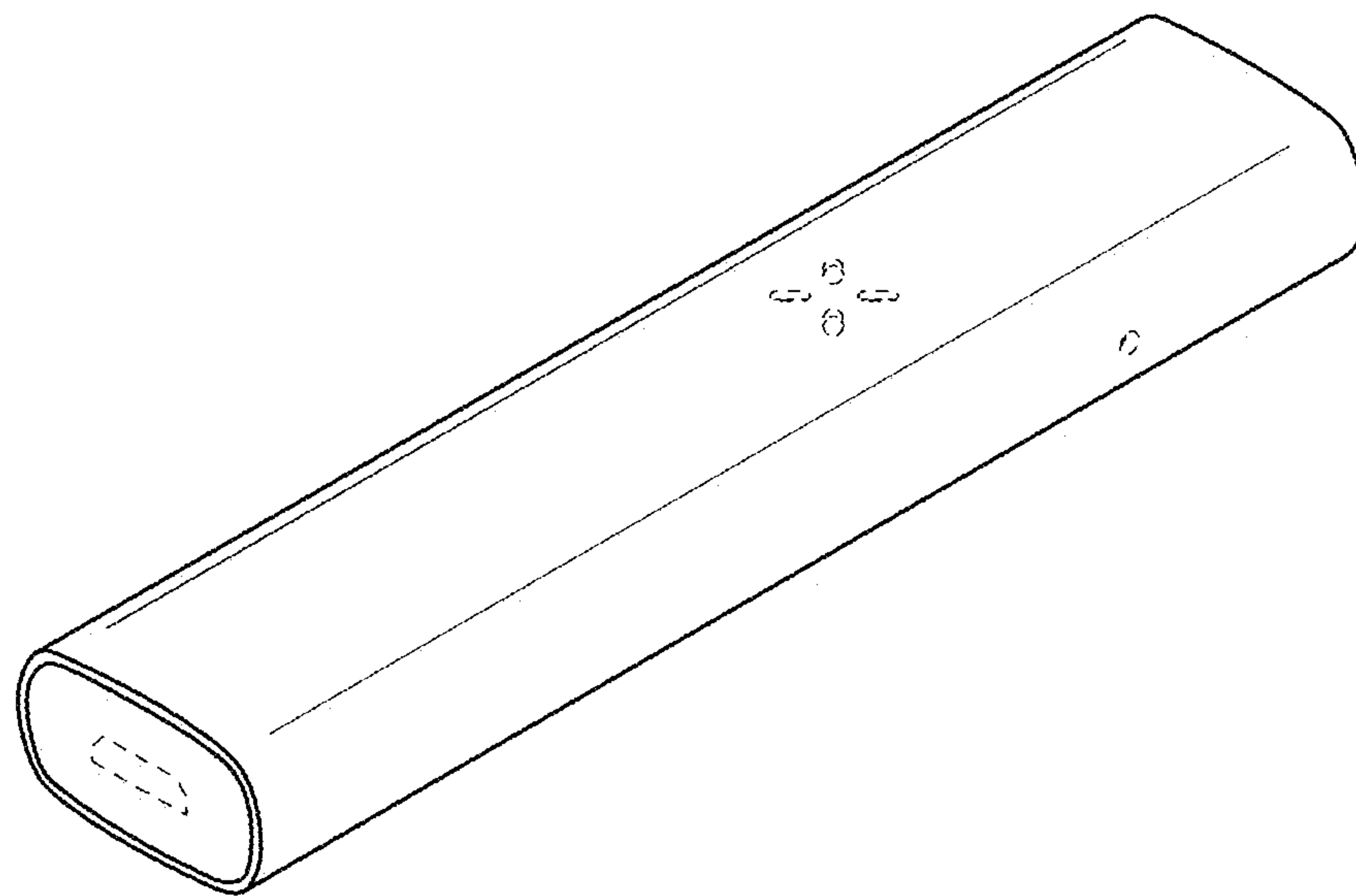

FIG. 1



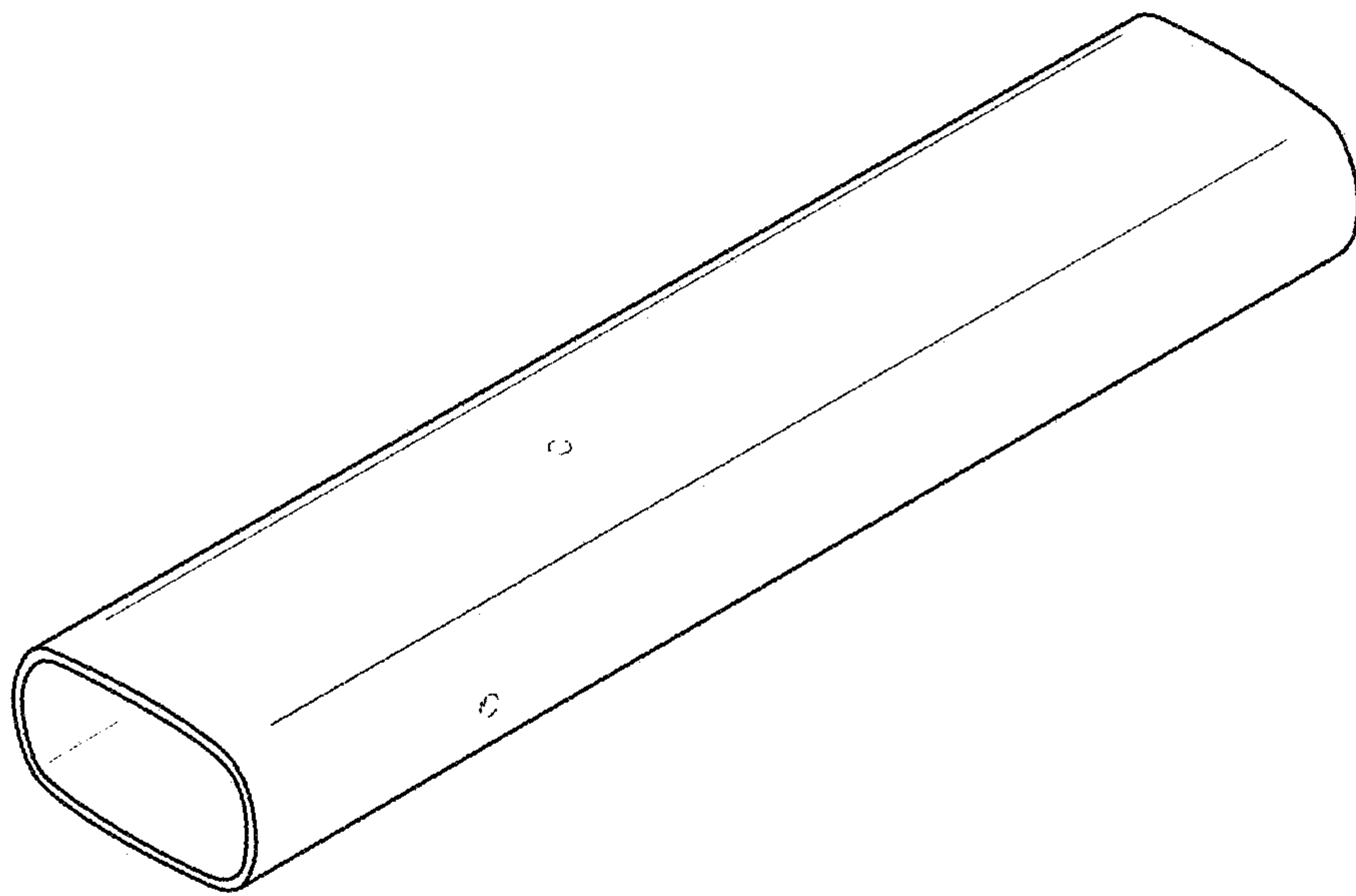

FIG. 2





FIG. 5

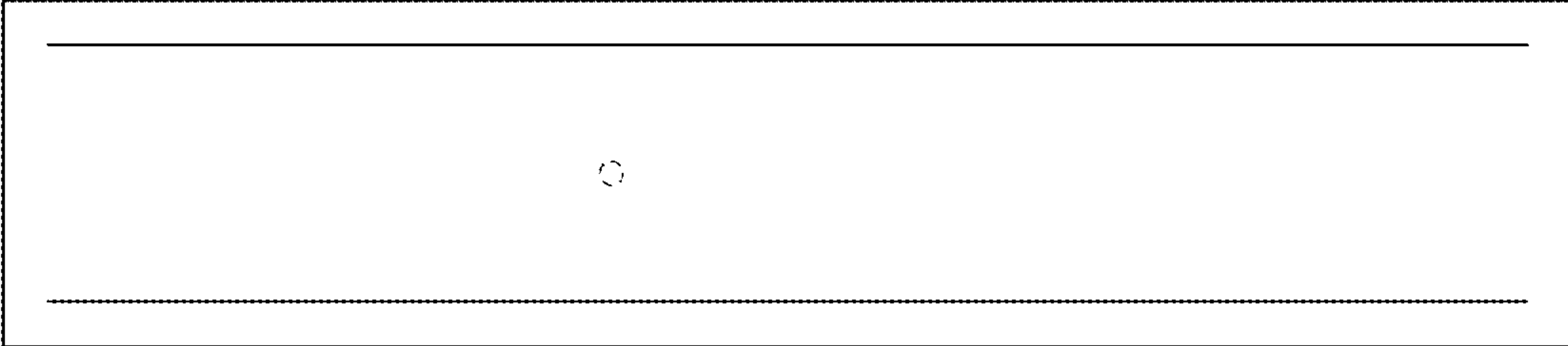

FIG. 4

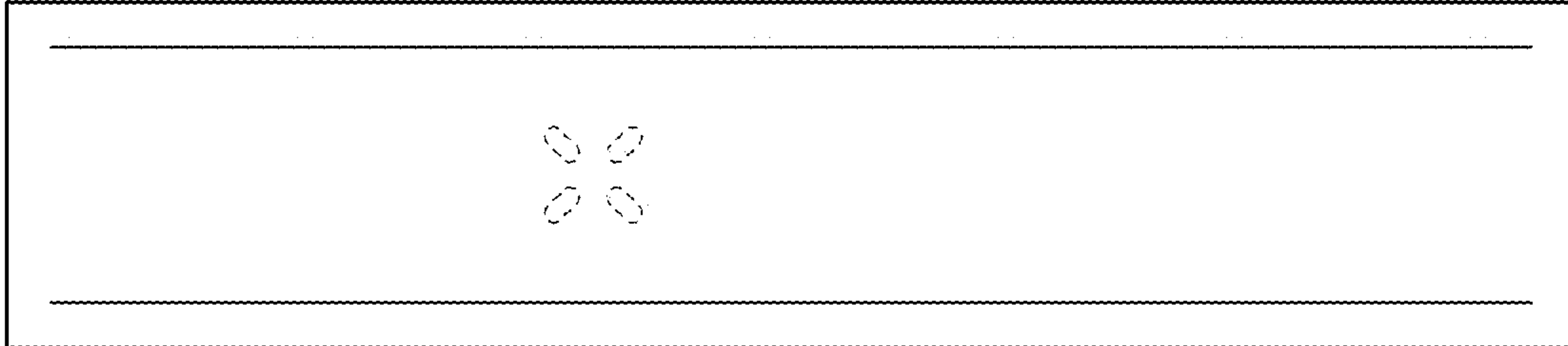

FIG. 3



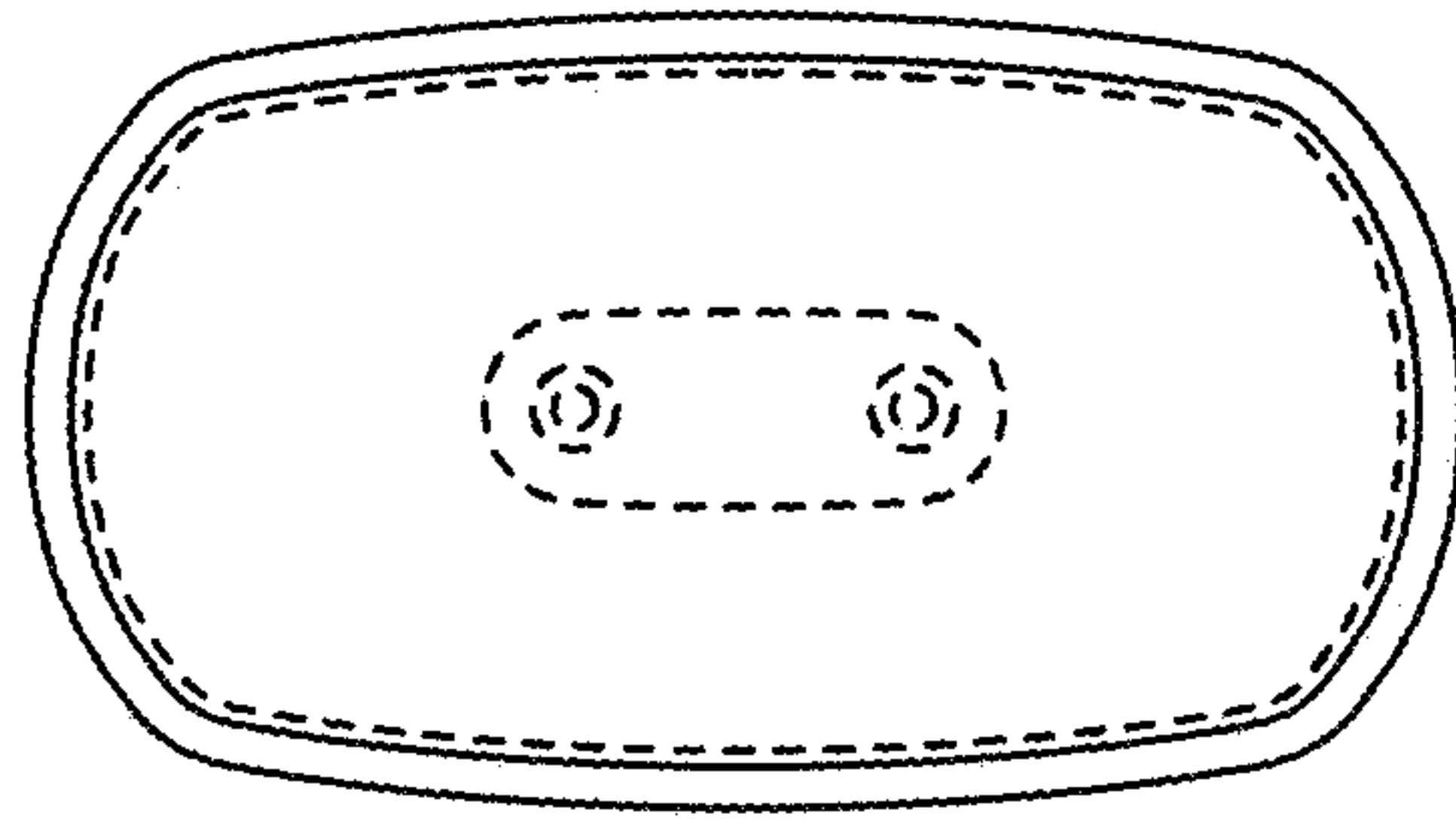

FIG. 6

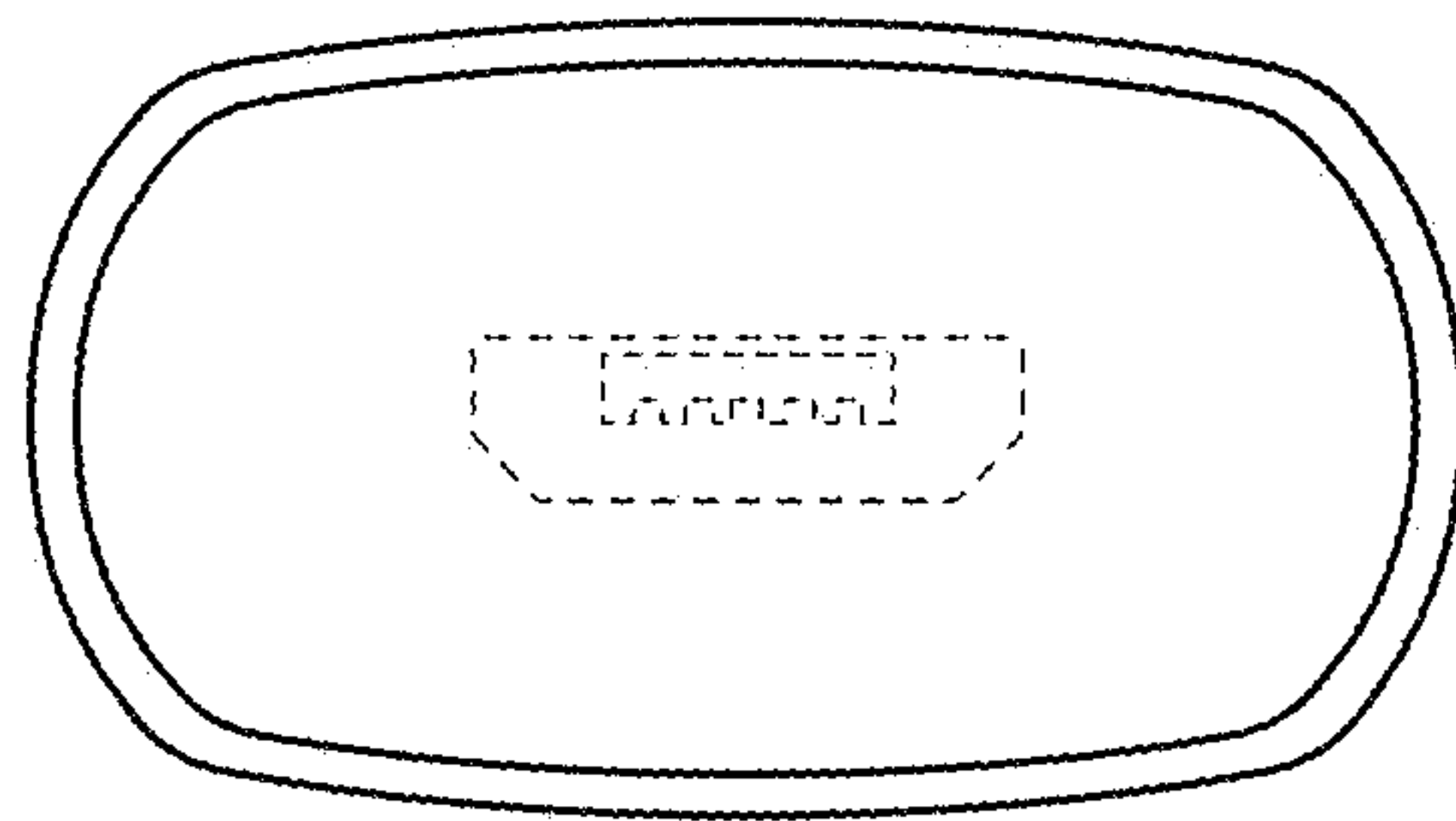

FIG. 7