



US00D913221S

(12) **United States Design Patent**  
**Druce et al.**

(10) **Patent No.:** **US D913,221 S**

(45) **Date of Patent:** **\*\* Mar. 16, 2021**

(54) **CHARGING DOCK**

(71) Applicant: **Nitto Denko Corporation**, Osaka (JP)

(72) Inventors: **Ben Druce**, Box Hill Vic (AU);  
**Andrew Kellock**, Box Hill Vic (AU)

(73) Assignee: **Nitto Denko Corporation**

(\*\*) Term: **15 Years**

(21) Appl. No.: **29/661,492**

(22) Filed: **Aug. 28, 2018**

(30) **Foreign Application Priority Data**

Mar. 2, 2018 (SG) ..... 30201805047Q

(51) **LOC (13) Cl.** ..... **13-02**

(52) **U.S. Cl.**  
USPC ..... **D13/108**

(58) **Field of Classification Search**

USPC ..... D13/103, 107–110, 118–119, 184, 199;  
D14/251, 253, 432, 434

CPC ..... H02J 7/0026; H02J 7/0042; H02J 7/0044;  
H02J 7/0045; H02J 7/0013; H02J 7/0003;  
H02J 50/00; H02J 50/10; H02J 50/12;  
H02J 50/80

See application file for complete search history.

(56) **References Cited**

**U.S. PATENT DOCUMENTS**

D275,482 S *	9/1984	Coons	.....	D13/108
D307,277 S *	4/1990	Desbarats	.....	455/561
D315,330 S *	3/1991	Soren	.....	D13/107
D337,303 S *	7/1993	Naft	.....	D13/108
D349,272 S *	8/1994	Sage	.....	D13/107
D378,911 S *	4/1997	Nagele	.....	D13/108
D385,530 S *	10/1997	Hames	.....	D13/107
D400,165 S *	10/1998	Nagele	.....	D13/108

D408,406 S *	4/1999	Shindo	.....	D13/108
D526,958 S *	8/2006	Shimizu	.....	D13/108
D532,370 S *	11/2006	Shimizu	.....	D13/108
D636,726 S *	4/2011	Hiramura	.....	D13/108
D654,018 S *	2/2012	Conley	.....	D13/107
D707,625 S *	6/2014	Ibuki	.....	D13/108
D749,507 S *	2/2016	Choi	.....	D13/108
D813,240 S *	3/2018	Yeruva	.....	D14/434
D862,454 S *	10/2019	Chun	.....	D14/253
D870,661 S *	12/2019	Virhia	.....	D13/108
D879,753 S *	3/2020	Boggs	.....	D14/240
D896,177 S *	9/2020	Zheng	.....	D13/108

\* cited by examiner

*Primary Examiner* — Rosemary K Tarcza

(74) *Attorney, Agent, or Firm* — Lerner, David,  
Littenberg, Krumholz & Mentlik, LLP

(57) **CLAIM**

The ornamental design for a charging dock, as shown and described.

**DESCRIPTION**

FIG. 1 is a front perspective view of a charging dock according to our new design;  
FIG. 2 is a front perspective view of the bottom thereof;  
FIG. 3 is a top plan view thereof;  
FIG. 4 is a bottom plan view thereof;  
FIG. 5 is a right side view thereof;  
FIG. 6 is a left side view thereof;  
FIG. 7 is a front elevation view thereof;  
FIG. 8 is a rear elevation view thereof;  
FIG. 9 is a cross-sectional view thereof, taken across line 9-9 of FIG. 6; and,  
FIG. 10 is a cross-sectional view thereof, taken across line 10-10 of FIG. 8.

The broken lines shown in the drawings are for the purpose of illustrating environmental structure and form no part of the claimed design.

**1 Claim, 7 Drawing Sheets**

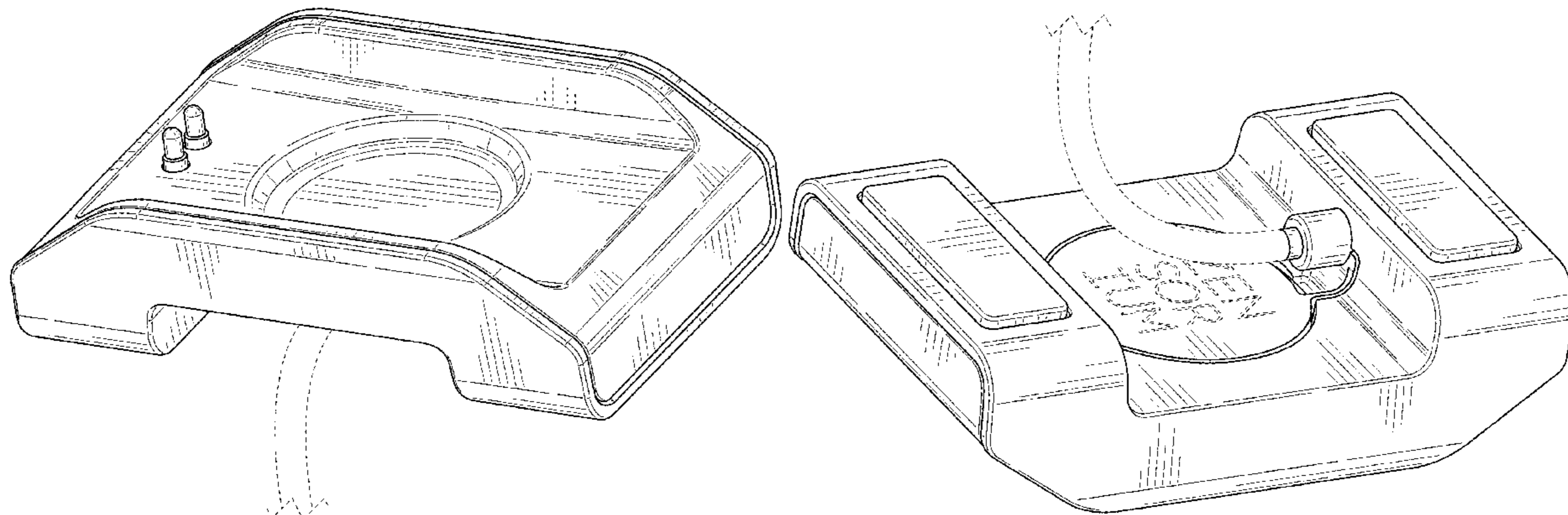

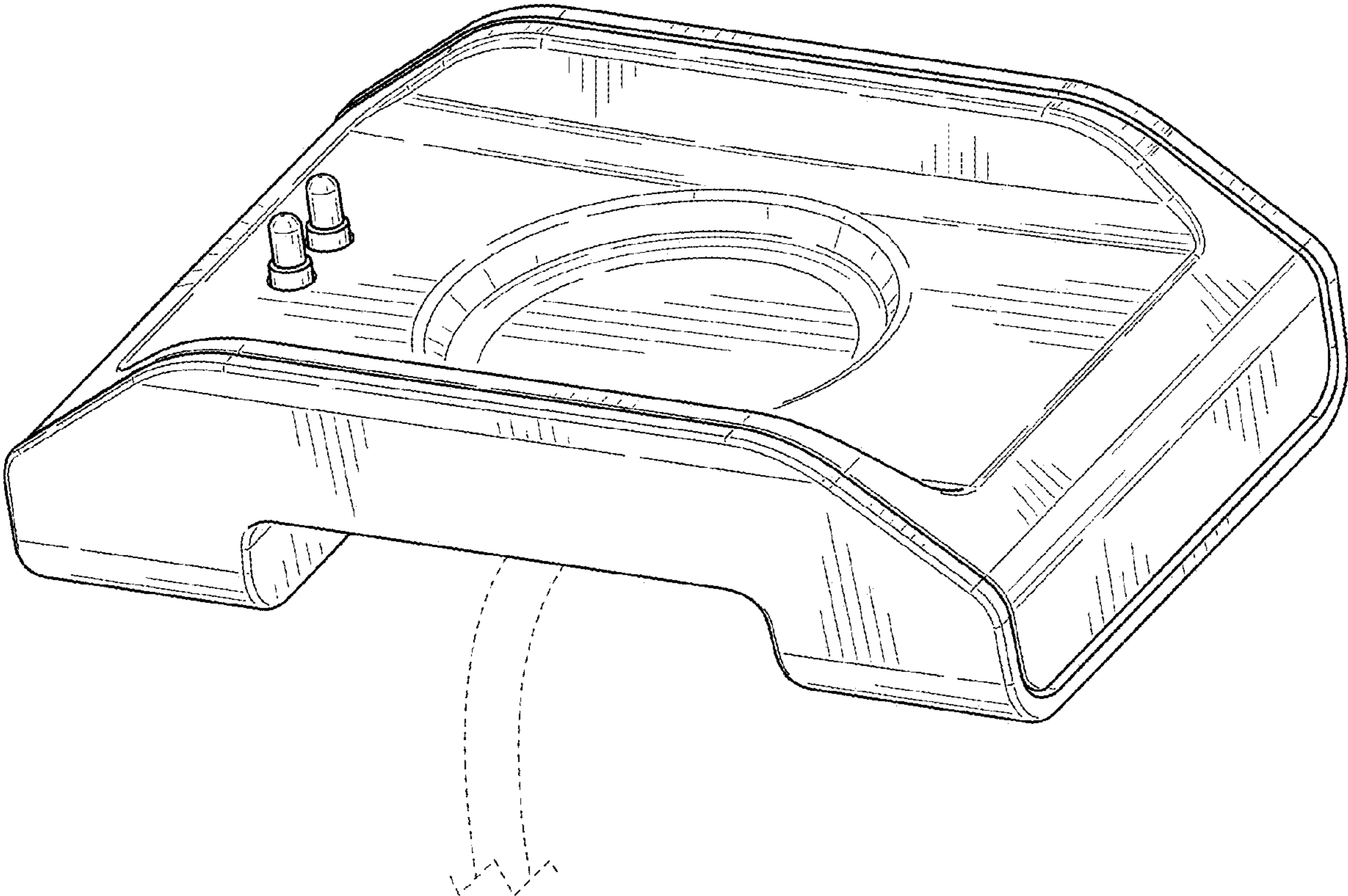

FIG. 1

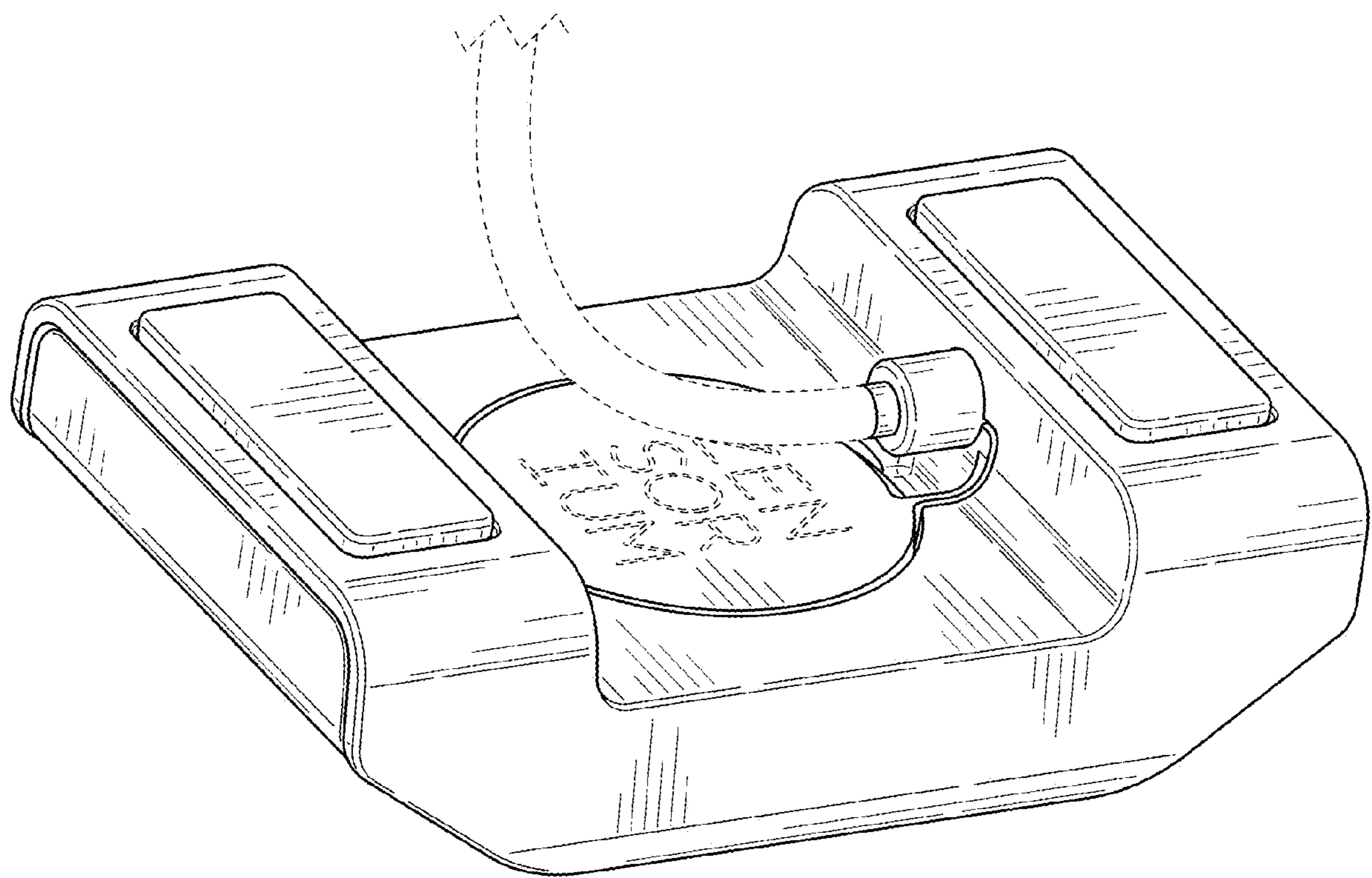

FIG. 2

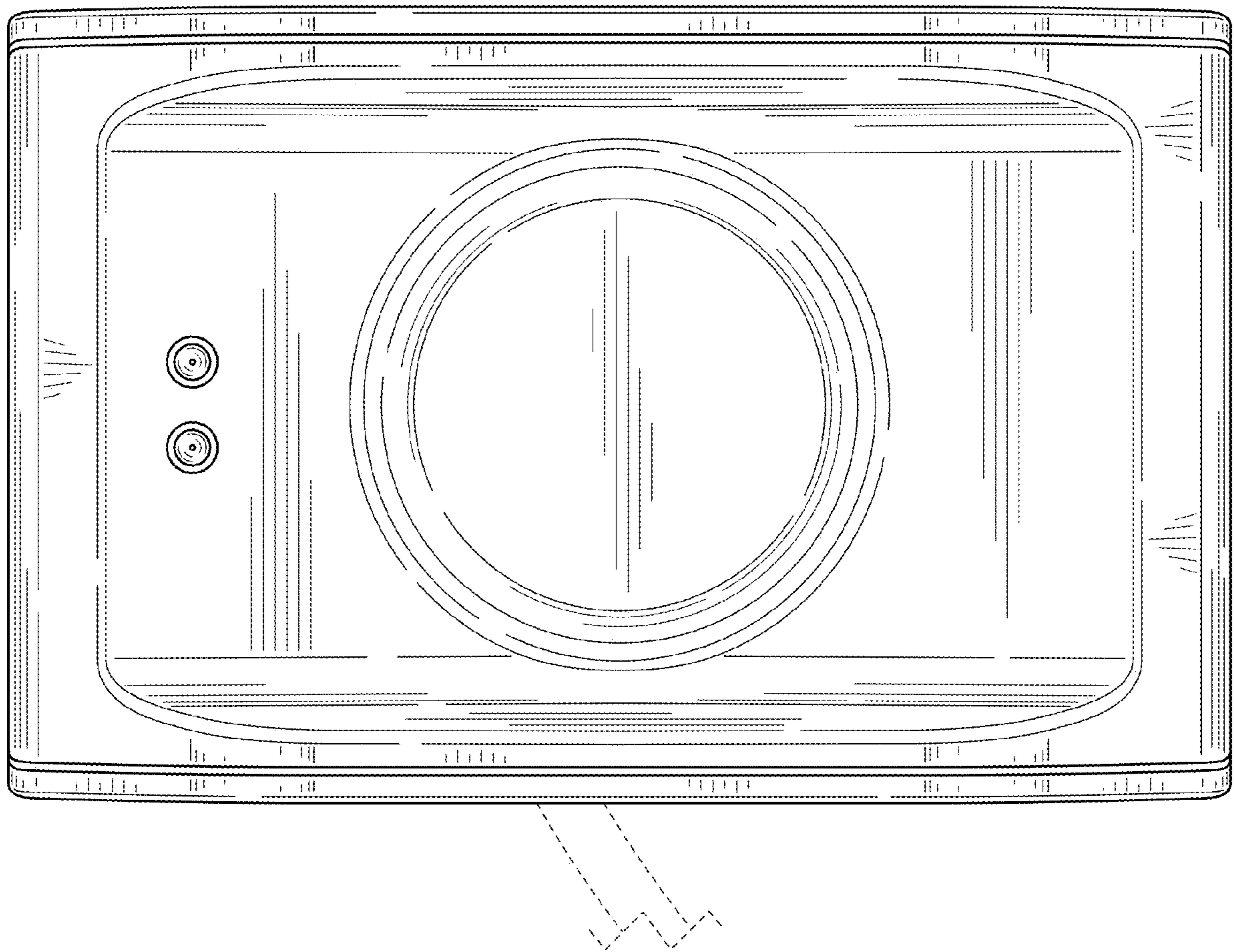

FIG. 3

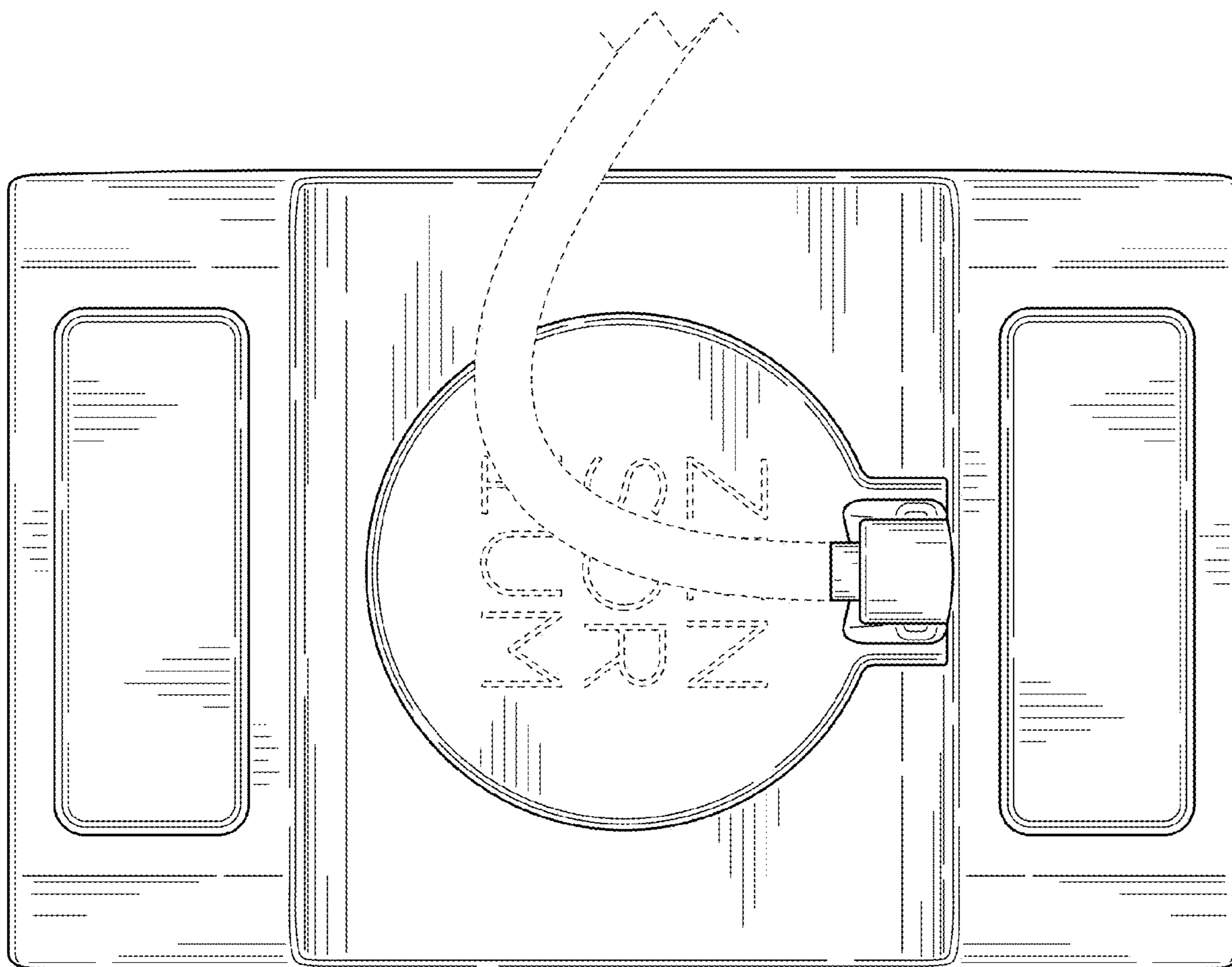

FIG. 4

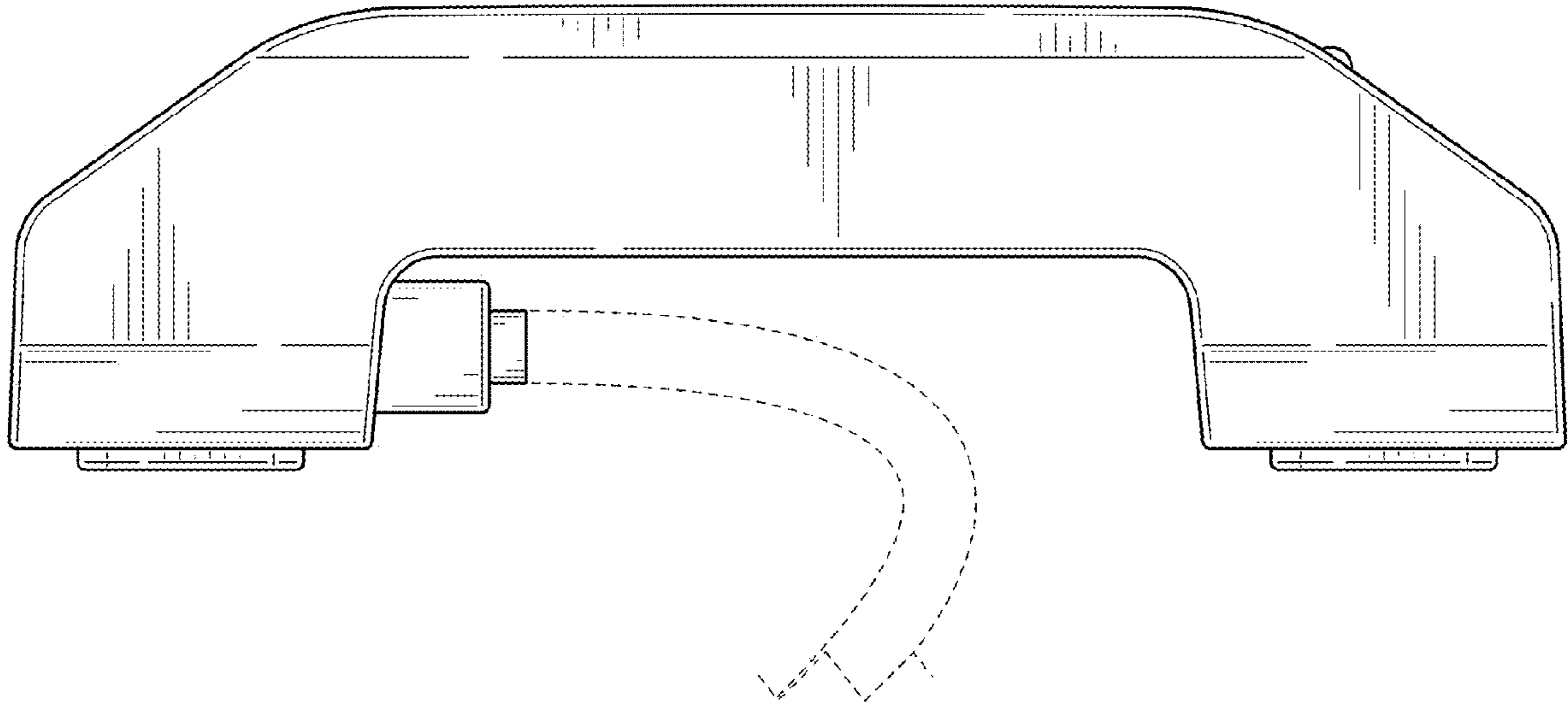

FIG. 5

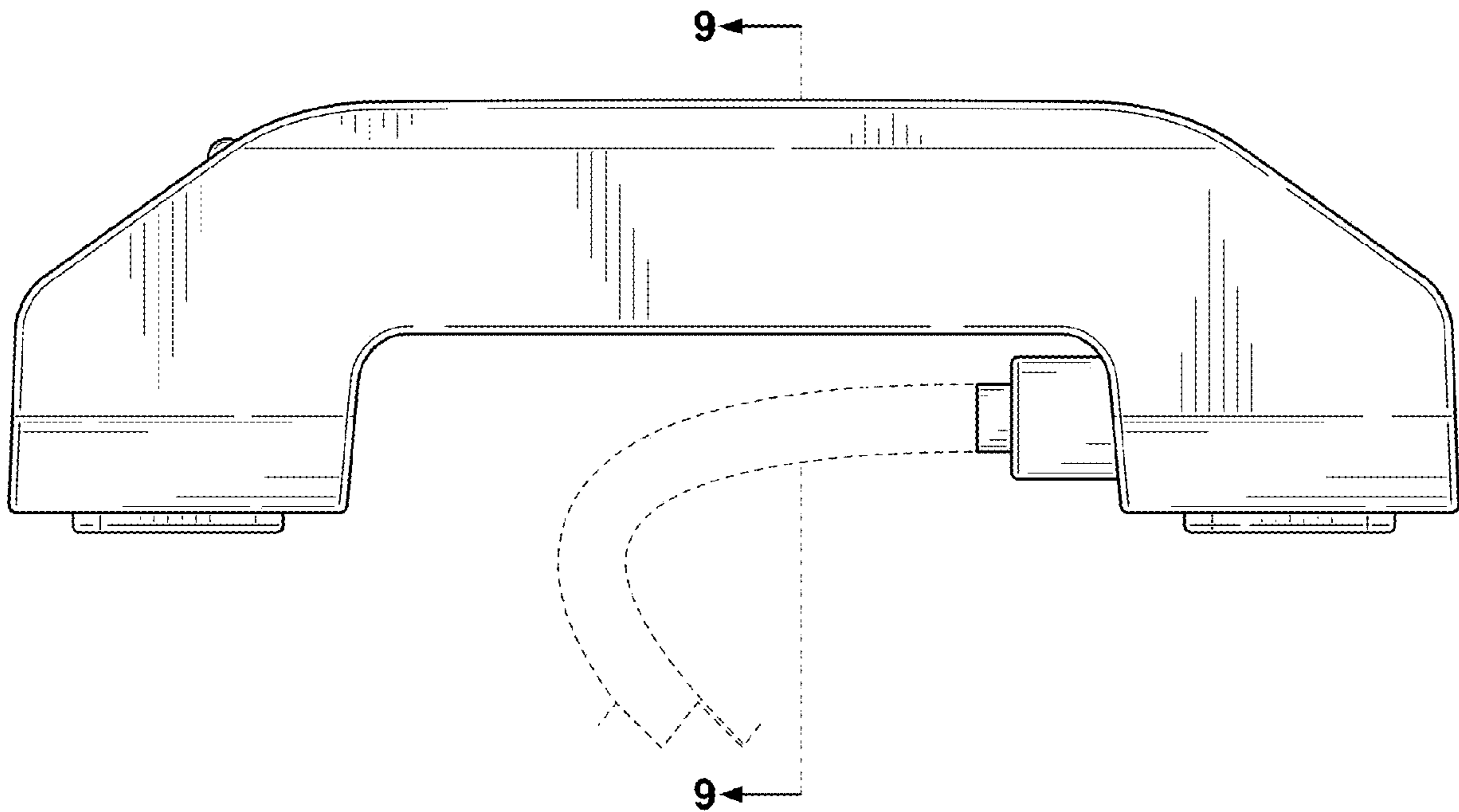

FIG. 6

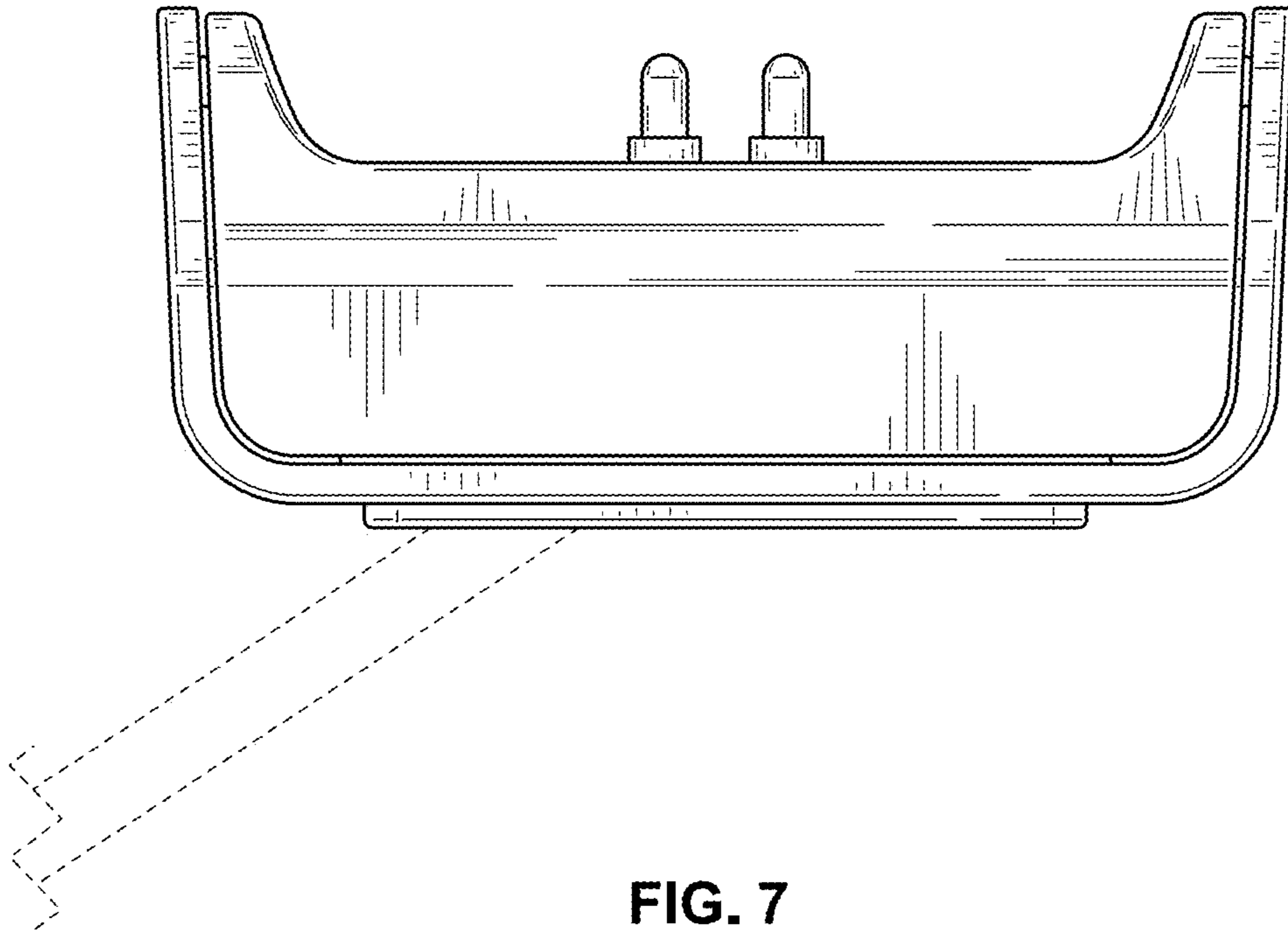

FIG. 7

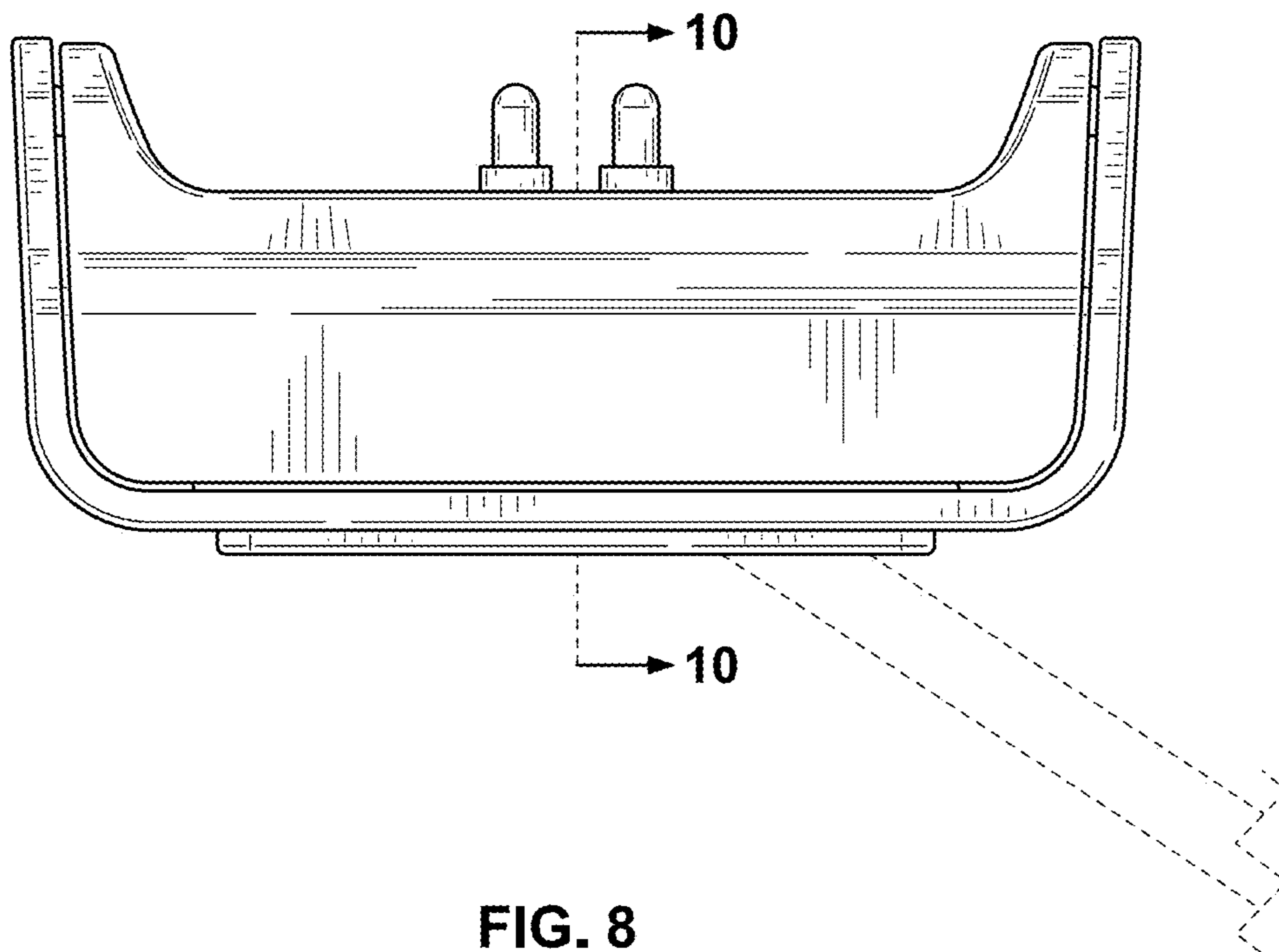

FIG. 8

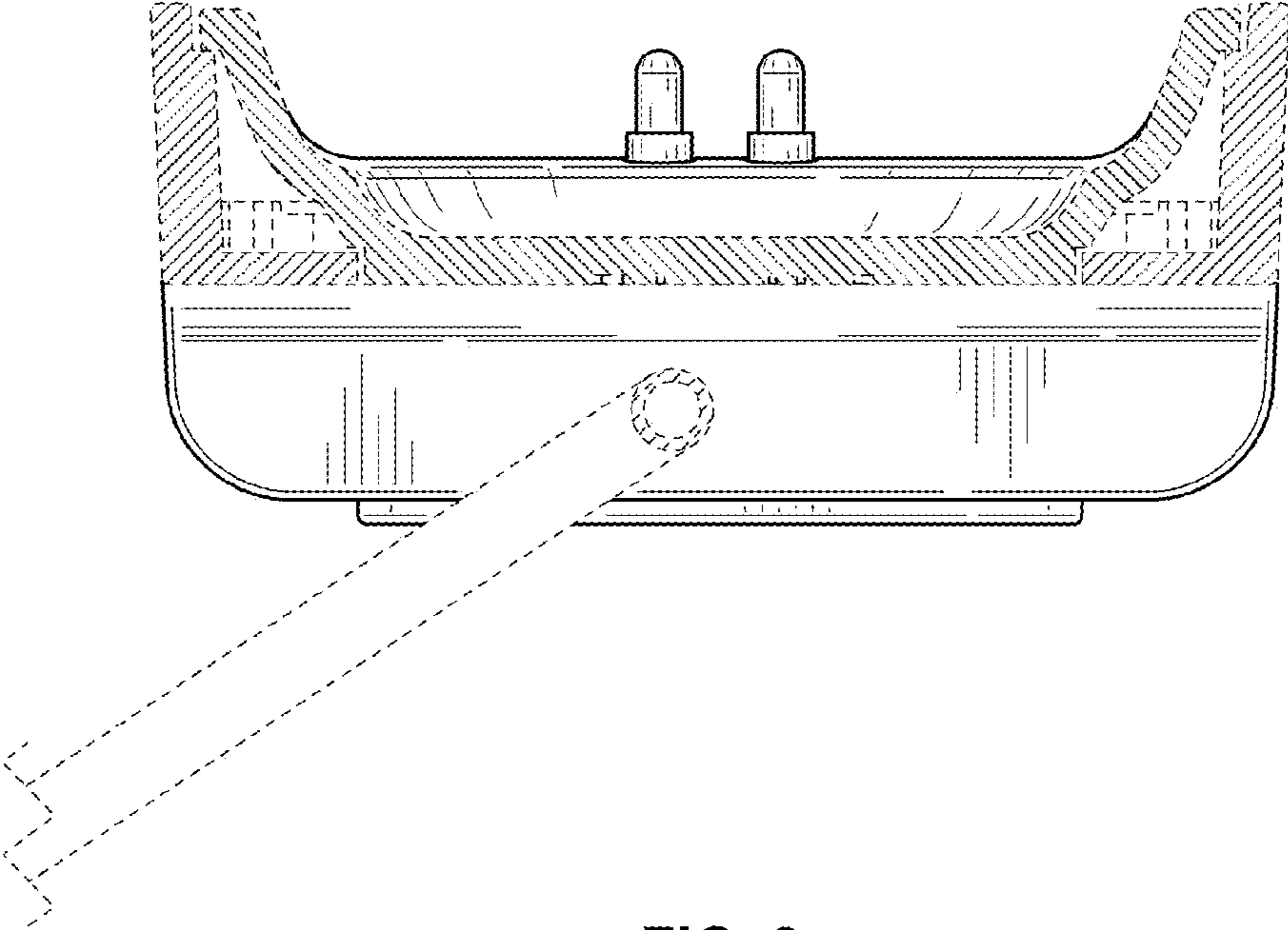

FIG. 9

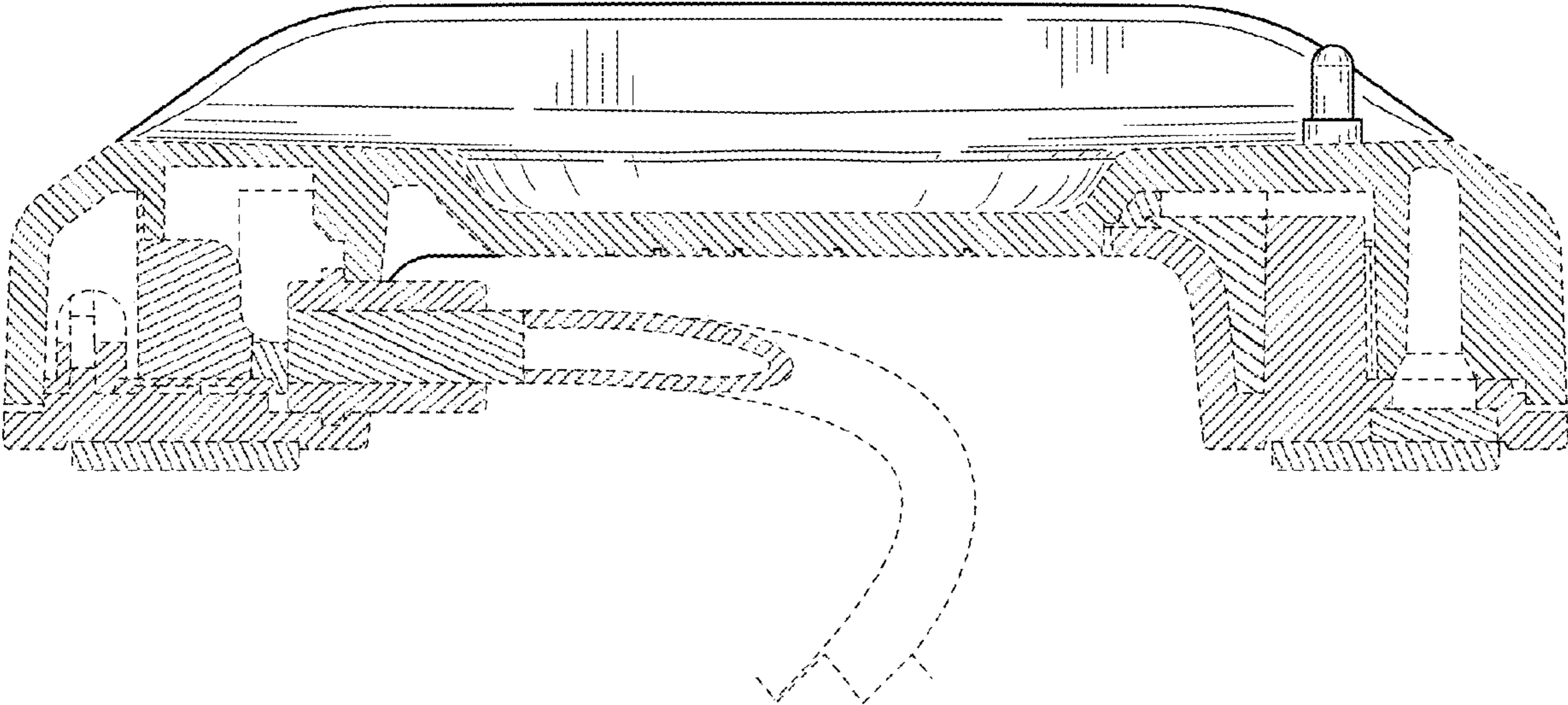

FIG. 10