



US00D913194S

(12) **United States Design Patent**
Duffy et al.

(10) **Patent No.:** **US D913,194 S**

(45) **Date of Patent:** **** Mar. 16, 2021**

- (54) **MULTI-ROTOR ROTORCRAFT**
- (71) Applicant: **The Boeing Company**, Chicago, IL (US)
- (72) Inventors: **Michael J. Duffy**, Lansdale, PA (US); **Joshua B. Jarvis**, St. Charles, MO (US); **Roger W. Lacy**, West Chester, PA (US); **David M. Neely**, Kirkwood, MO (US); **Eric J. Schulze**, Hockessin, DE (US)

D776,569	S *	1/2017	Baruchin	D12/16.1
D787,373	S *	5/2017	Ketcher	D12/16.1
D808,860	S *	1/2018	Tian	D12/16.1
9,862,487	B2 *	1/2018	Werner	A63H 27/12
9,944,386	B1 *	4/2018	Reichert	B64C 27/20
D854,967	S *	7/2019	Yu	D12/16.1
D855,007	S *	7/2019	Hu	D12/328
D867,470	S *	11/2019	Haley	D21/436
2008/0048065	A1 *	2/2008	Kuntz	B64C 39/024 244/17.23

(Continued)

- (73) Assignee: **The Boeing Company**, Chicago, IL (US)

(**) Term: **15 Years**

(21) Appl. No.: **29/693,329**

(22) Filed: **May 31, 2019**

Related U.S. Application Data

- (63) Continuation of application No. 29/690,053, filed on May 3, 2019.

(51) **LOC (13) Cl.** **12-07**

(52) **U.S. Cl.**
USPC **D12/328**

(58) **Field of Classification Search**
USPC D12/1, 2, 3, 4, 16.1, 174, 319-345;
D15/436-455; D13/109
CPC B64C 29/0033; B64C 2201/021; B64C
29/02; B64C 2201/088; B64C 2201/104;
B64C 2201/141
See application file for complete search history.

(56) **References Cited**

U.S. PATENT DOCUMENTS

D708,272	S *	7/2014	Schmelter	D12/16.1
8,950,698	B1	2/2015	Rossi		
8,954,206	B2	2/2015	Criado		
9,475,575	B2	10/2016	Rossi		

OTHER PUBLICATIONS

Printout of webpage for Bell Nexus from Bell Flight, 2018, downloaded from BellFlight.com on May 24, 2019.

Primary Examiner — John A Voytek

(74) *Attorney, Agent, or Firm* — Dascenzo Gates Intellectual Property Law, P.C.

(57) **CLAIM**

The ornamental design for a multi-rotor rotorcraft, as shown and described.

DESCRIPTION

FIG. 1 is a perspective view of a multi-rotor rotorcraft showing the new design; FIG. 2 is another perspective view thereof; FIG. 3 is a front view thereof; FIG. 4 is a rear view thereof; FIG. 5 is a right side view thereof; FIG. 6 is a left side view thereof; FIG. 7 is a top view thereof; and, FIG. 8 is a bottom view thereof.

The broken lines shown in the drawings represent portions of the multi-rotor rotorcraft that form no part of the claimed design. The shading lines shown in the drawings represent the three-dimensional contour of the claimed design and are not intended to indicate surface decoration.

1 Claim, 6 Drawing Sheets

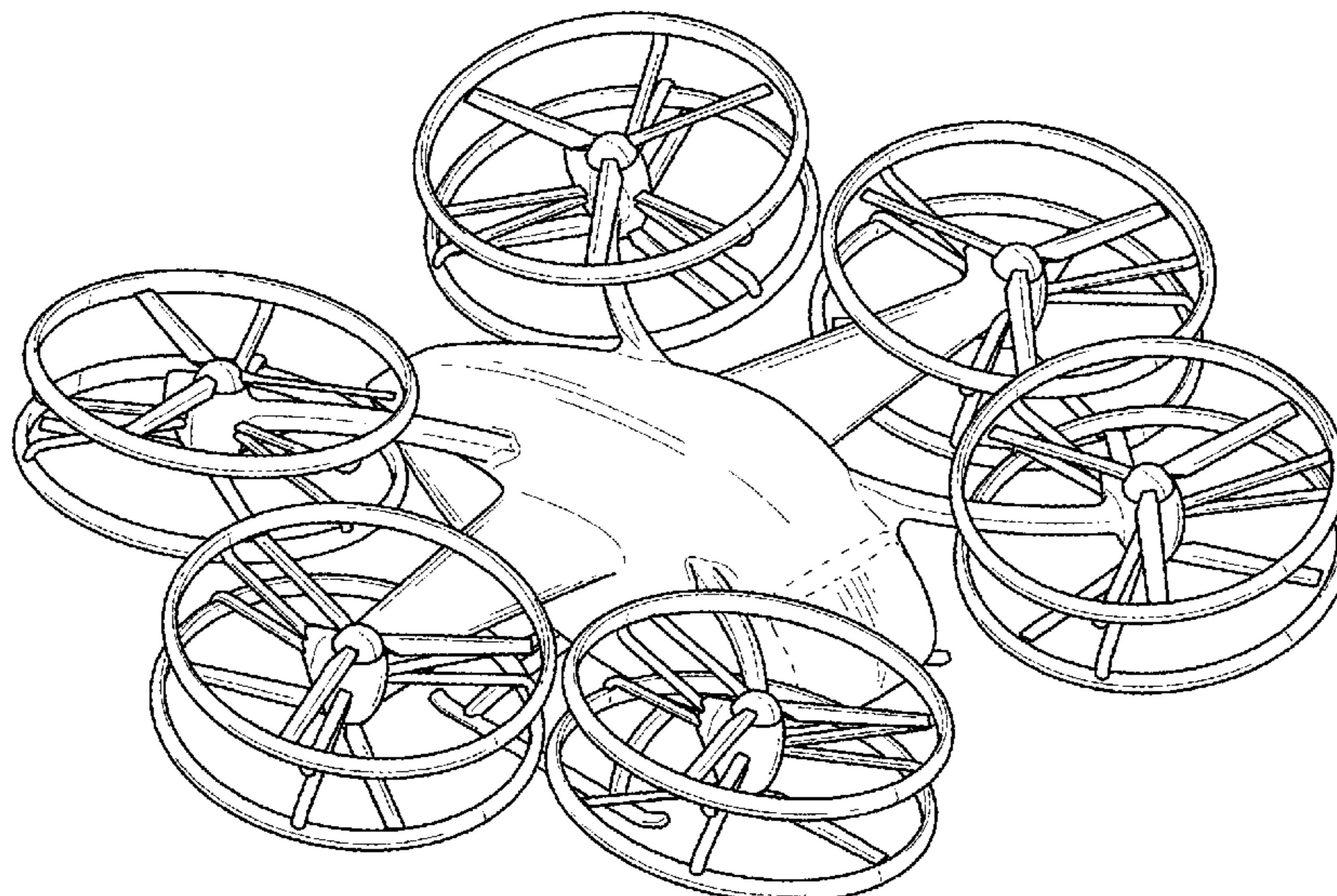

(56)

References Cited

U.S. PATENT DOCUMENTS

2013/0175390 A1 7/2013 Woodworth et al.
2015/0110388 A1 7/2015 Criado et al.
2016/0304194 A1* 10/2016 Bevirt B64C 27/30
2020/0115045 A1* 4/2020 Mermoz B64C 27/24

* cited by examiner

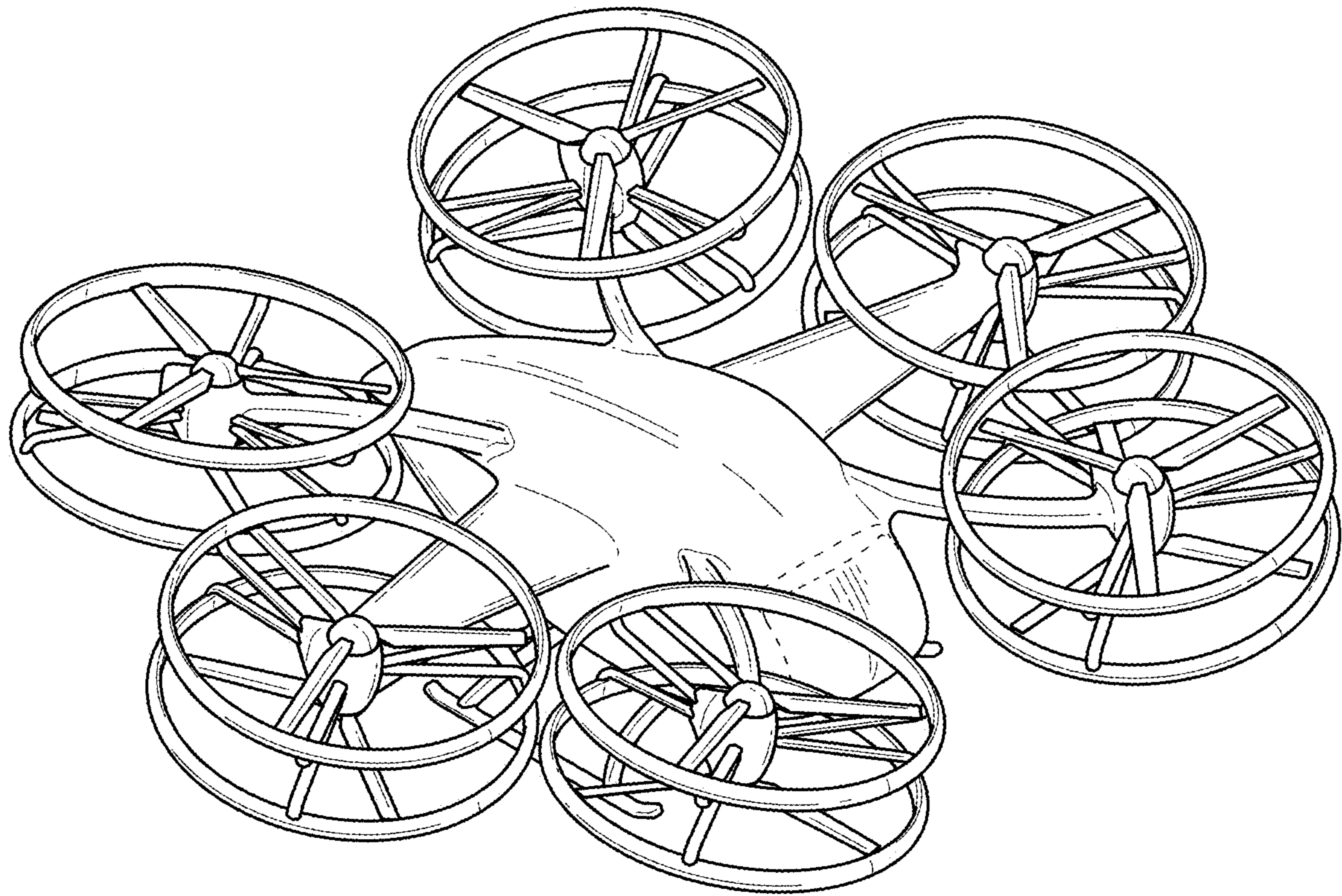

FIG. 1

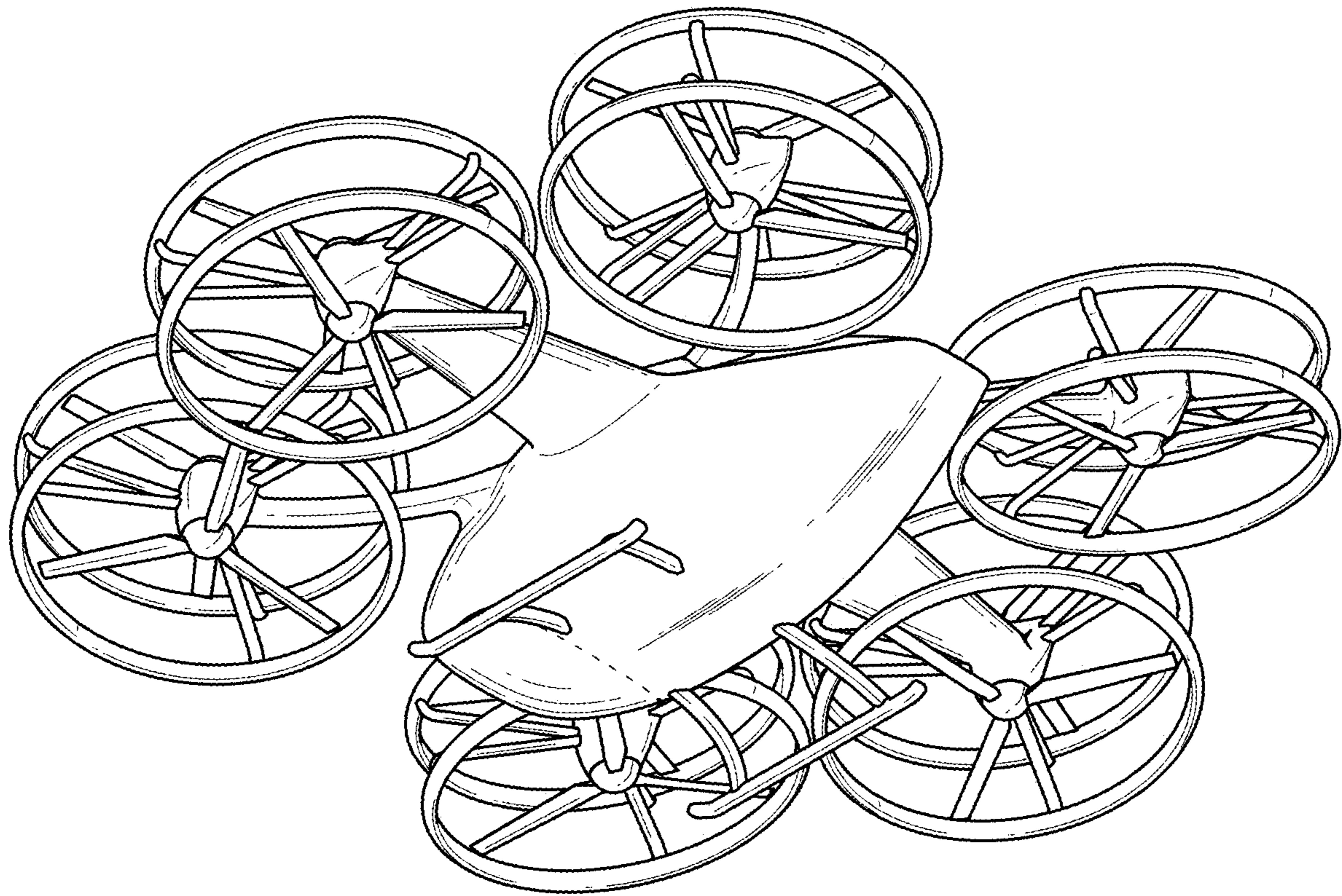

FIG. 2

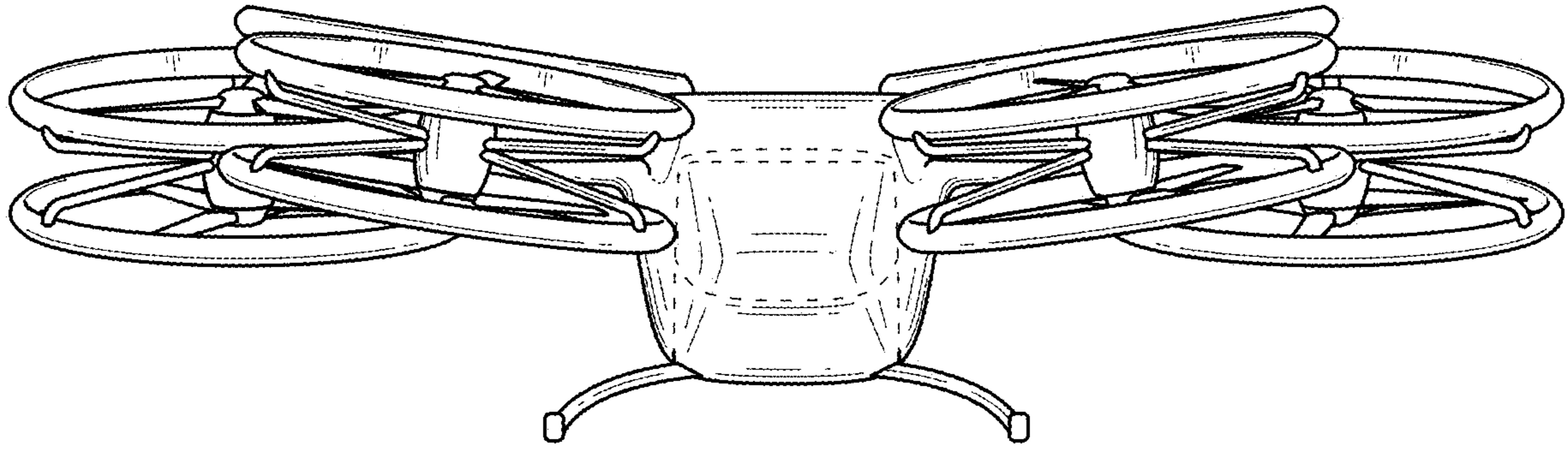

FIG. 3

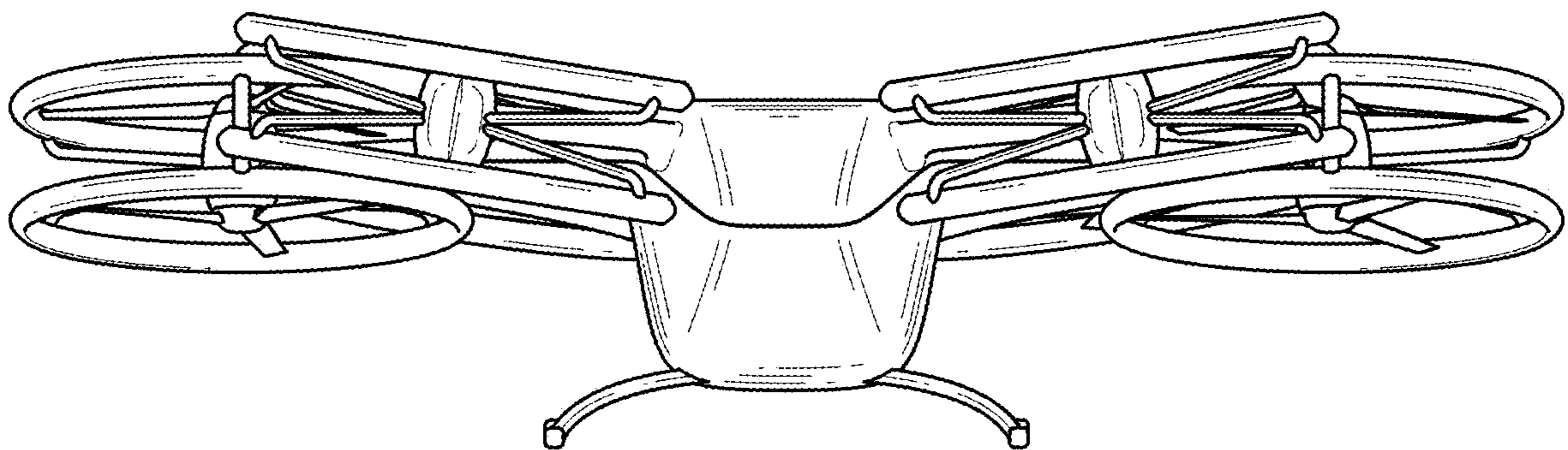

FIG. 4

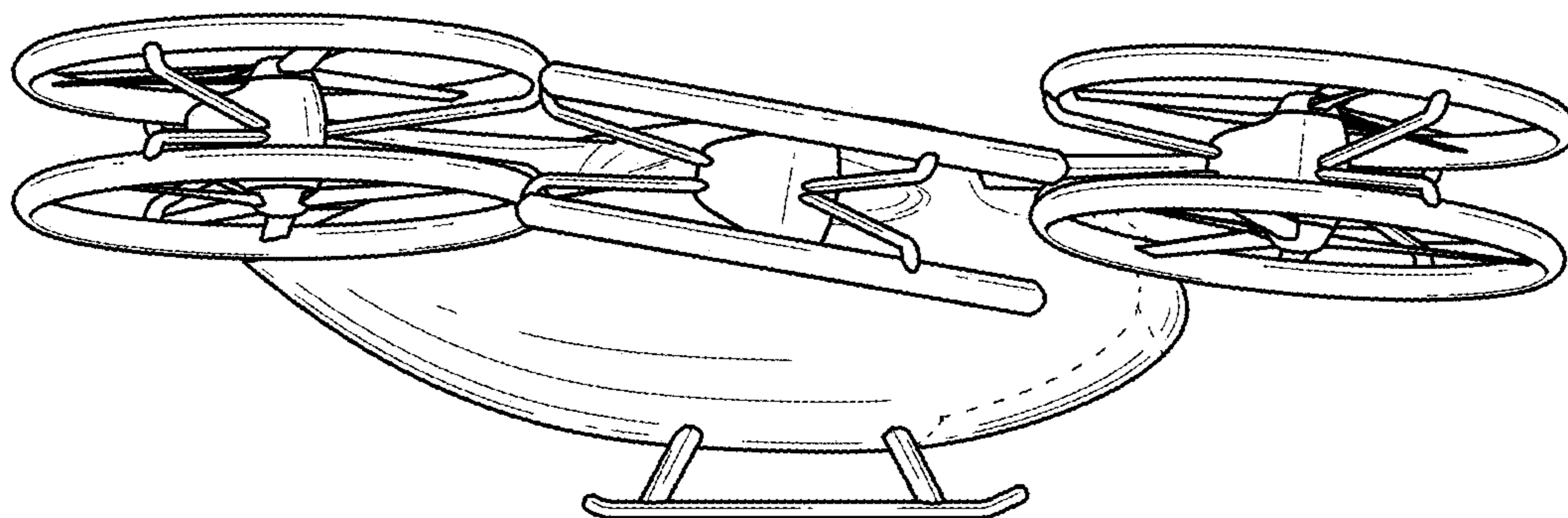

FIG. 5

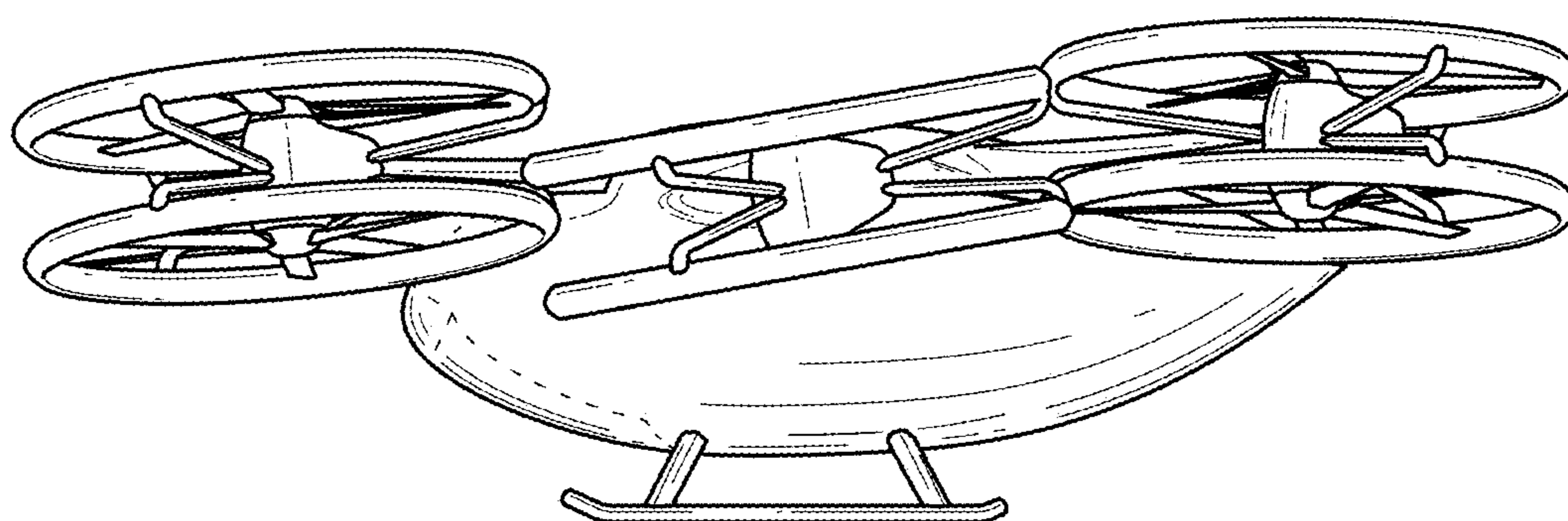

FIG. 6

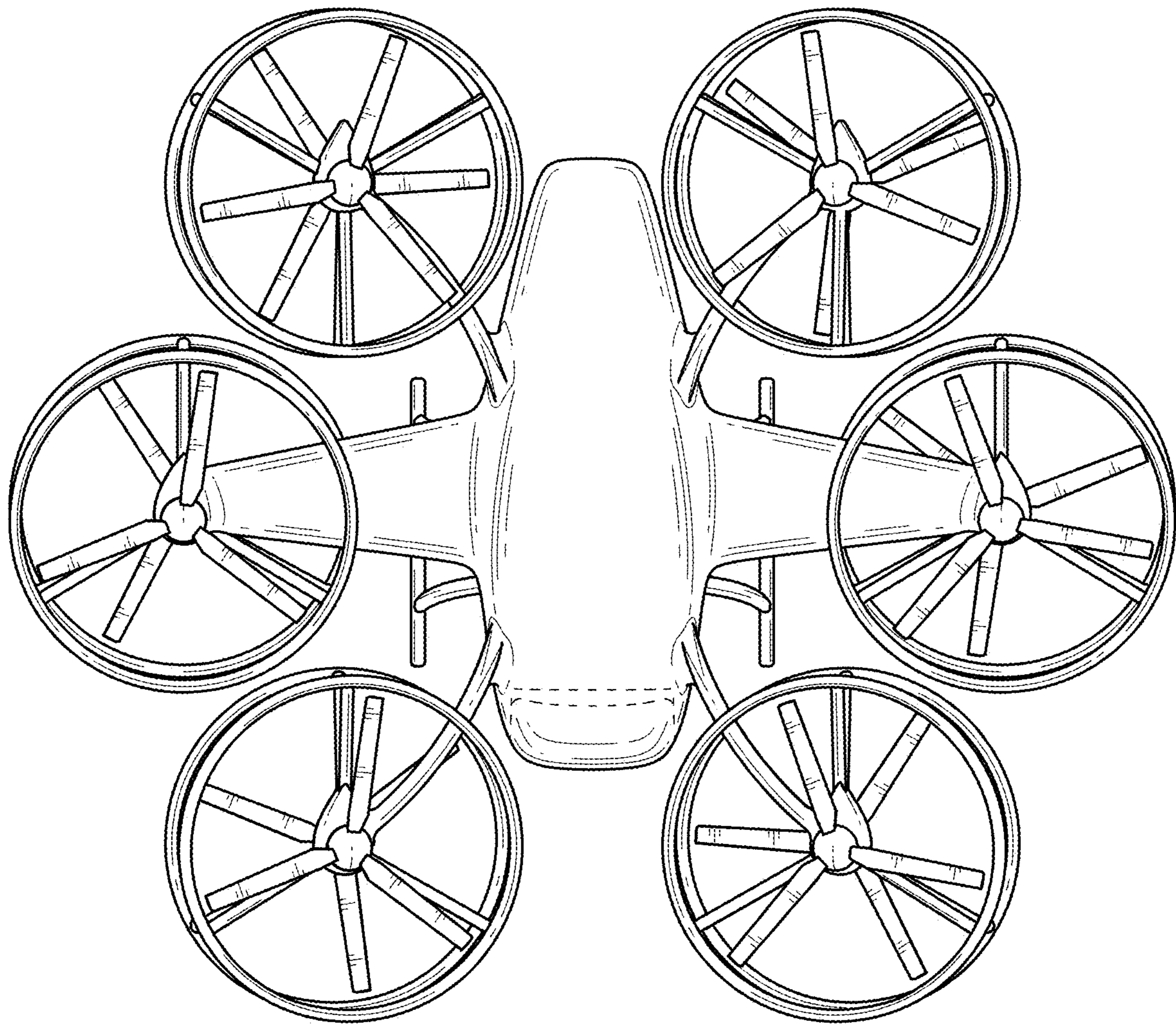

FIG. 7

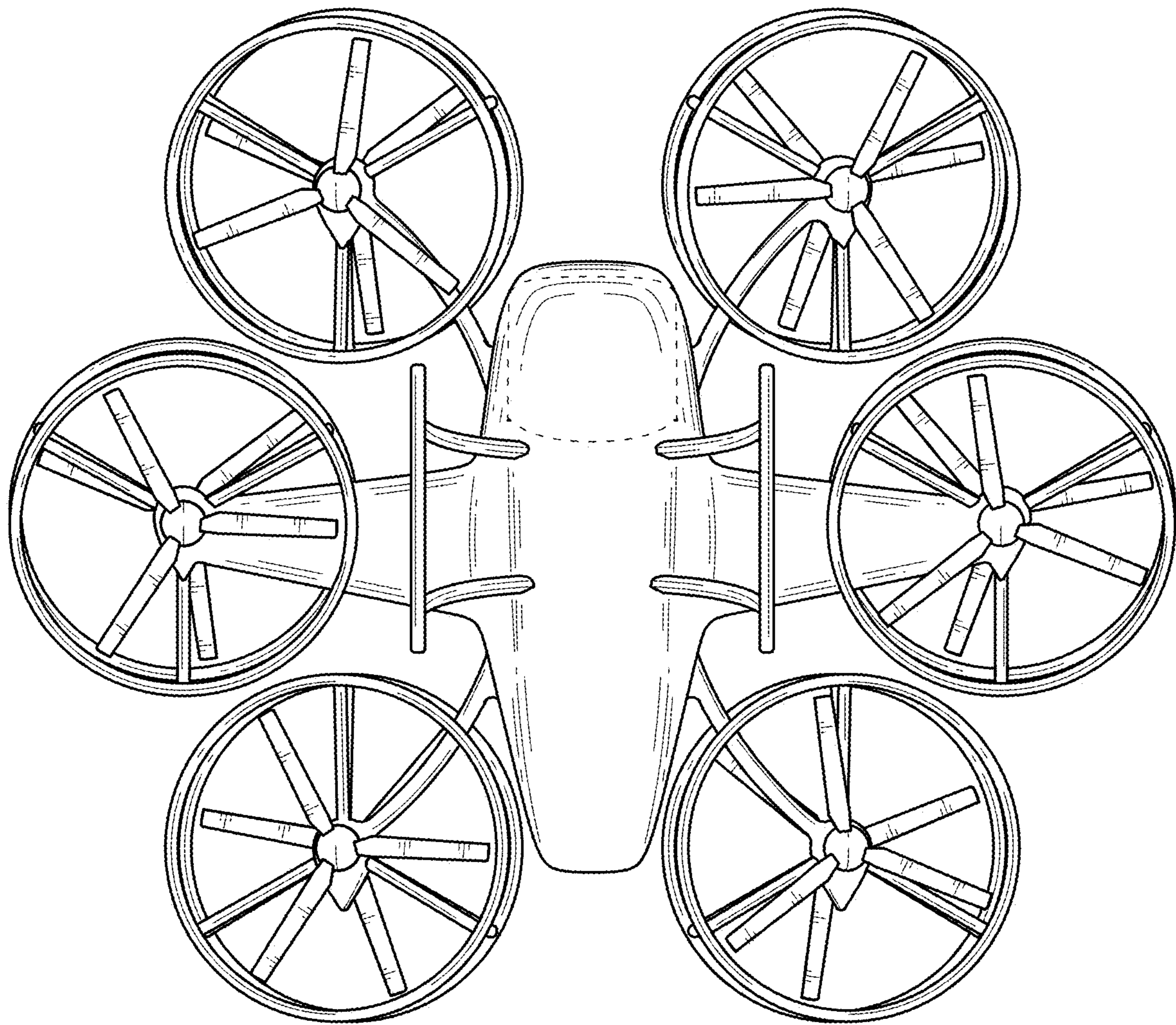

FIG. 8