



US00D913060S

(12) **United States Design Patent**
DeFrancia

(10) **Patent No.:** **US D913,060 S**
(45) **Date of Patent:** **** Mar. 16, 2021**

(54) **MULTI-COMPARTMENT CARRIER**

(71) Applicant: **Ice Rover, Inc.**, Niwot, CO (US)

(72) Inventor: **Tomas A. DeFrancia**, Niwot, CO (US)

(73) Assignee: **Ice Rover, Inc.**, Niwot, CO (US)

(**) Term: **15 Years**

(21) Appl. No.: **29/743,707**

(22) Filed: **Jul. 23, 2020**

(51) **LOC (13) Cl.** **07-01**

(52) **U.S. Cl.**
USPC **D7/706; D7/310**

(58) **Field of Classification Search**
USPC D7/605, 701, 705-708; D3/304,
D3/307-312, 313-345
CPC F25D 3/08; F25D 31/007; A47L 13/51;
B65D 1/243; B65D 1/22; B65D 1/26;
B65D 71/0003

See application file for complete search history.

(56) **References Cited**

U.S. PATENT DOCUMENTS

2,501,772	A *	3/1950	Guard	F25D 31/007	220/592.16
3,182,884	A	5/1965	Waldron			
4,204,596	A *	5/1980	Davis	B65D 1/243	206/139
4,234,114	A *	11/1980	Wood	B65D 71/0003	206/162
D386,616	S *	11/1997	Nimer	D3/308	
D396,749	S	8/1998	Ortiz			
D484,011	S *	12/2003	Strobel	D3/309	
D553,361	S *	10/2007	Splain	D3/304	
D635,415	S	4/2011	Chin			
8,230,697	B2 *	7/2012	Lavallee	F25D 3/08	62/457.7
8,608,015	B2	12/2013	Wolf et al.			

8,800,317	B2	8/2014	Dallas et al.			
D783,287	S *	4/2017	Swartzel	D3/305	
D808,736	S	1/2018	Acord			
D885,846	S	6/2020	Woodall			
2005/0092640	A1 *	5/2005	Woodward	B65D 1/243	206/427
2011/0252824	A1 *	10/2011	Dallas	B65D 25/2891	62/457.5
2012/0097555	A1 *	4/2012	Munn	B65D 71/0003	206/139

(Continued)

Primary Examiner — Terry A Wallace

(74) *Attorney, Agent, or Firm* — Lieberman & Brandsdorfer, LLC

(57) **CLAIM**

The ornamental design for a multi-compartment carrier, as shown and described.

DESCRIPTION

FIG. 1 is a front perspective view of a multi-compartment carrier showing my new design.
 FIG. 2 is a front view thereof.
 FIG. 3 is a rear view thereof.
 FIG. 4 is a left side view thereof.
 FIG. 5 is a right side view thereof.
 FIG. 6 is a top plan view thereof.
 FIG. 7 is a bottom plan view thereof.
 FIG. 8 is a top plan view thereof with a handle of the multi-compartment carrier positioned at the rear of the carrier; and,
 FIG. 9 is a front perspective view thereof.
 The broken lines are included in FIGS. 1, 6, 8, and 9 to represent portions of the multi-compartment carrier that are not considered part of the claimed design. Broken lines in FIG. 9 showing beverages and ice illustrate environmental structure and are for illustrative purposes only. The broken lines form no part of the claimed design.

1 Claim, 9 Drawing Sheets

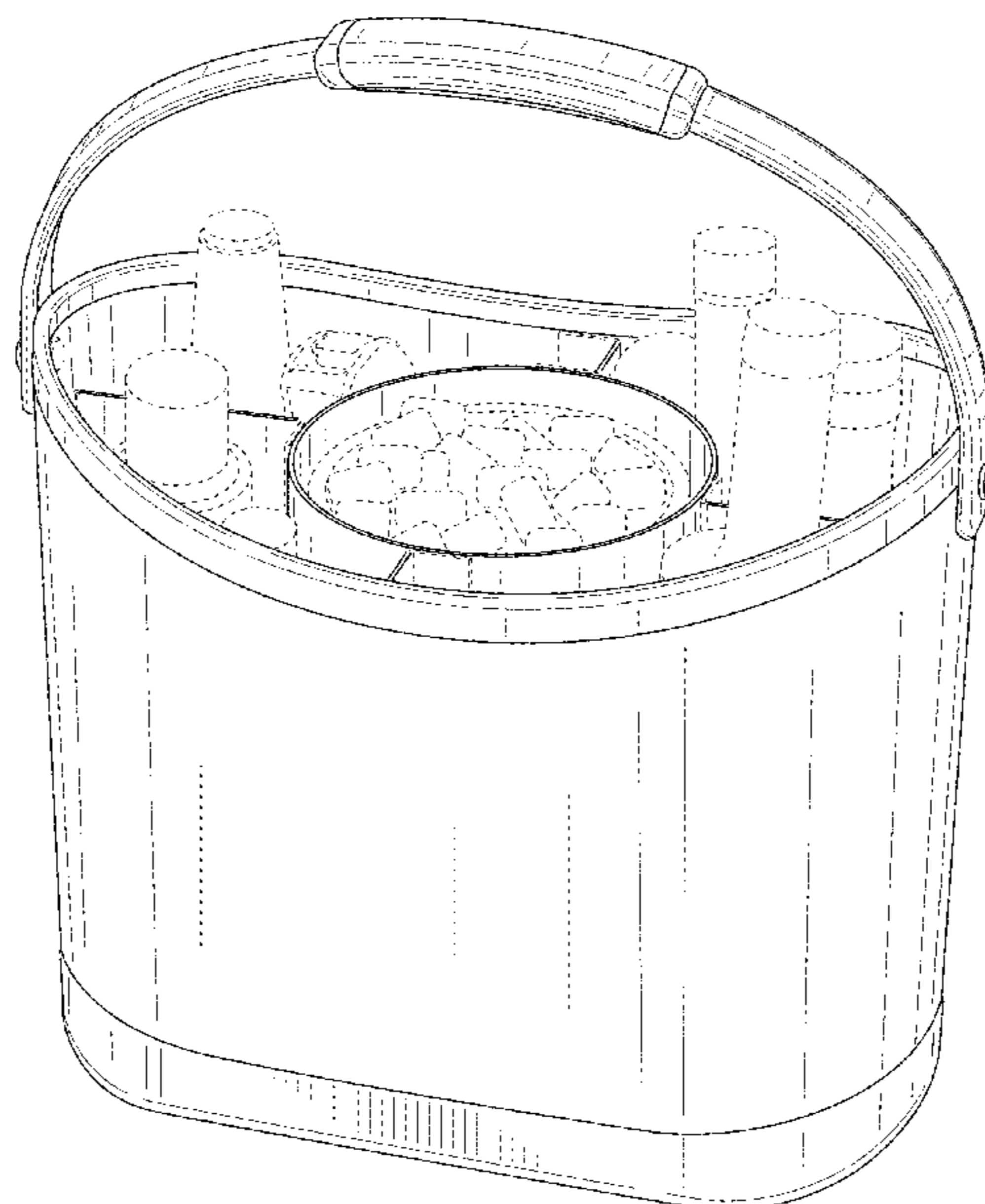

(56)

References Cited

U.S. PATENT DOCUMENTS

2013/0233011 A1 9/2013 Wolf
2017/0008659 A1 1/2017 Brewster

* cited by examiner

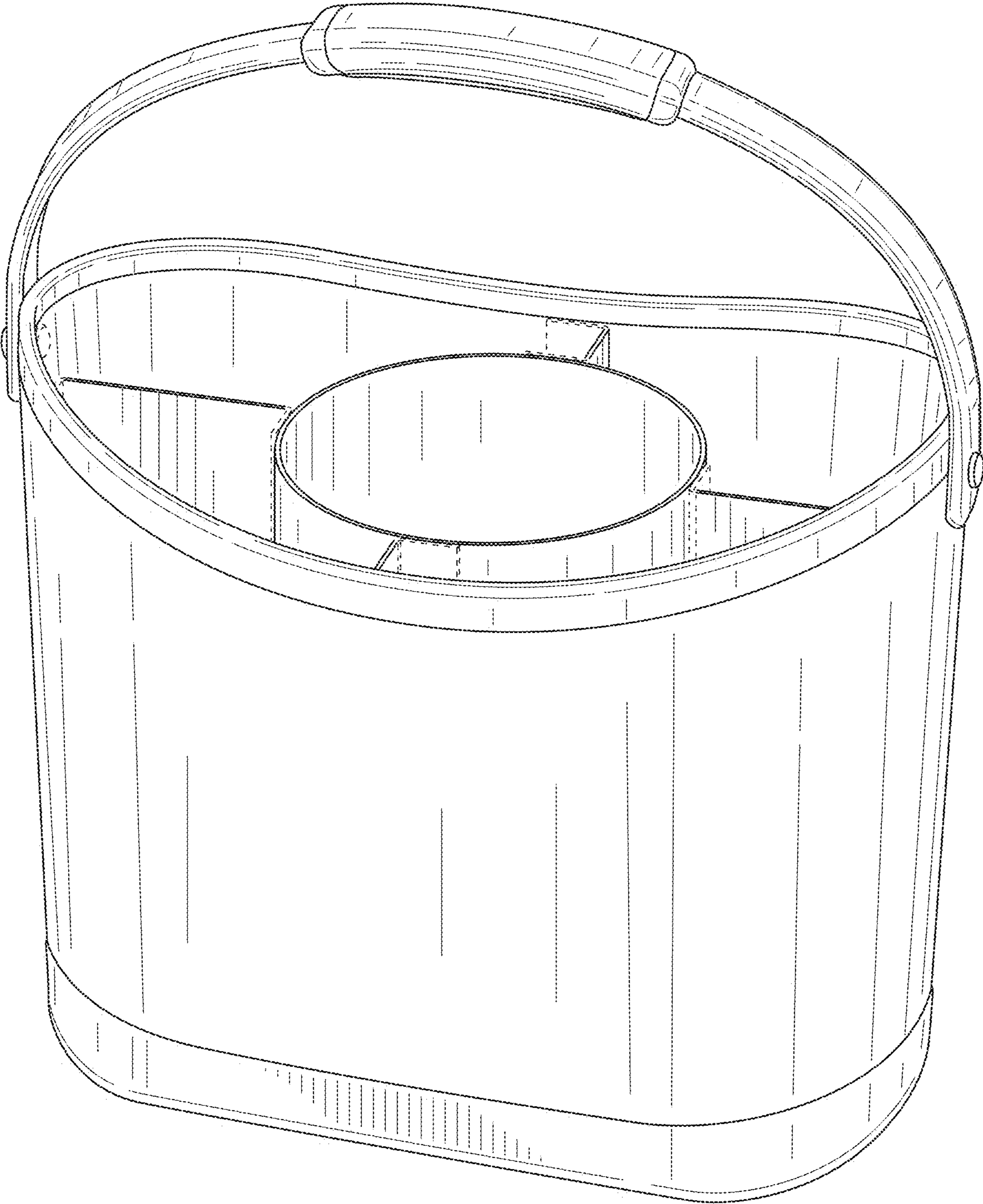

FIG. 1

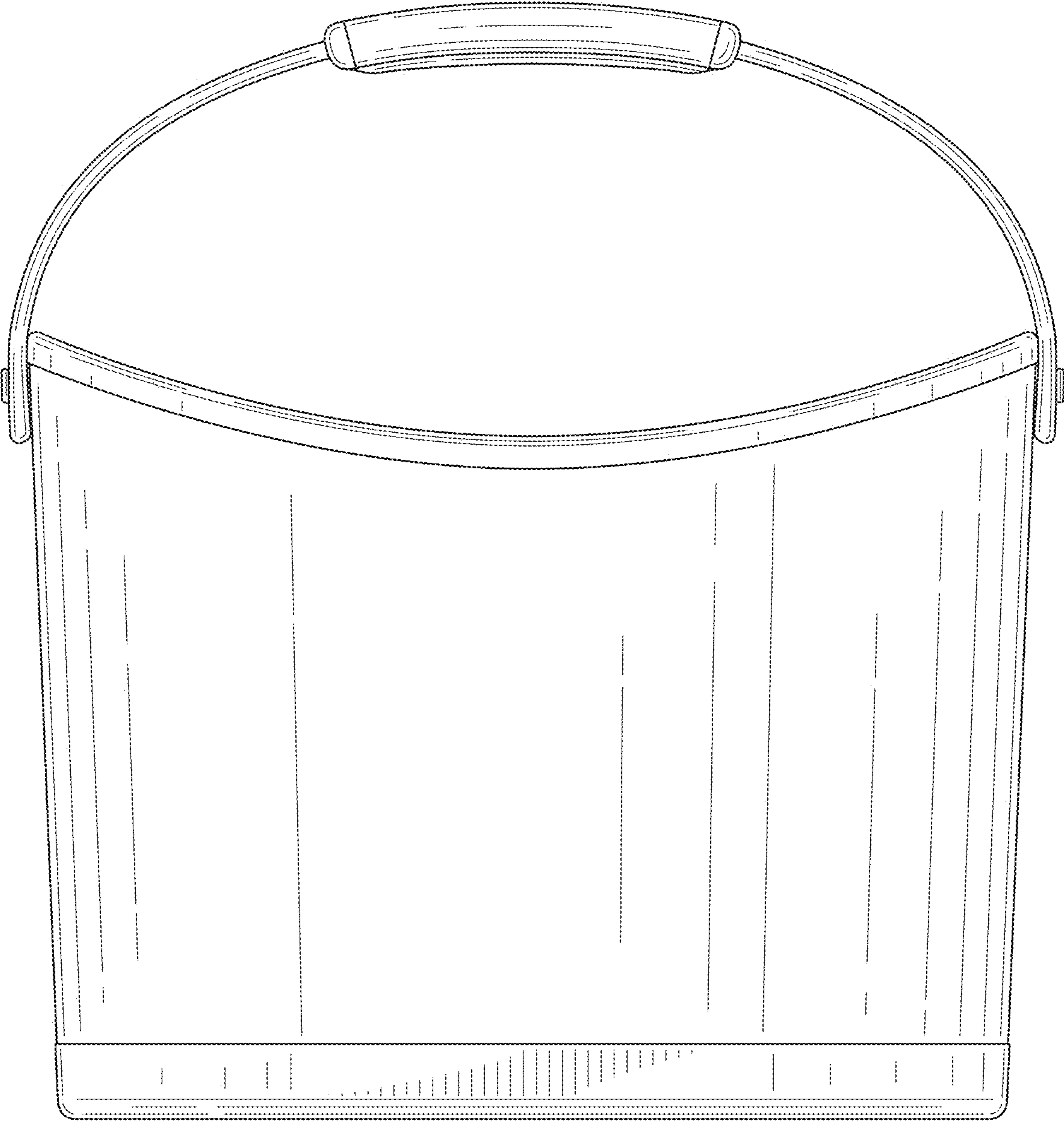

FIG. 2

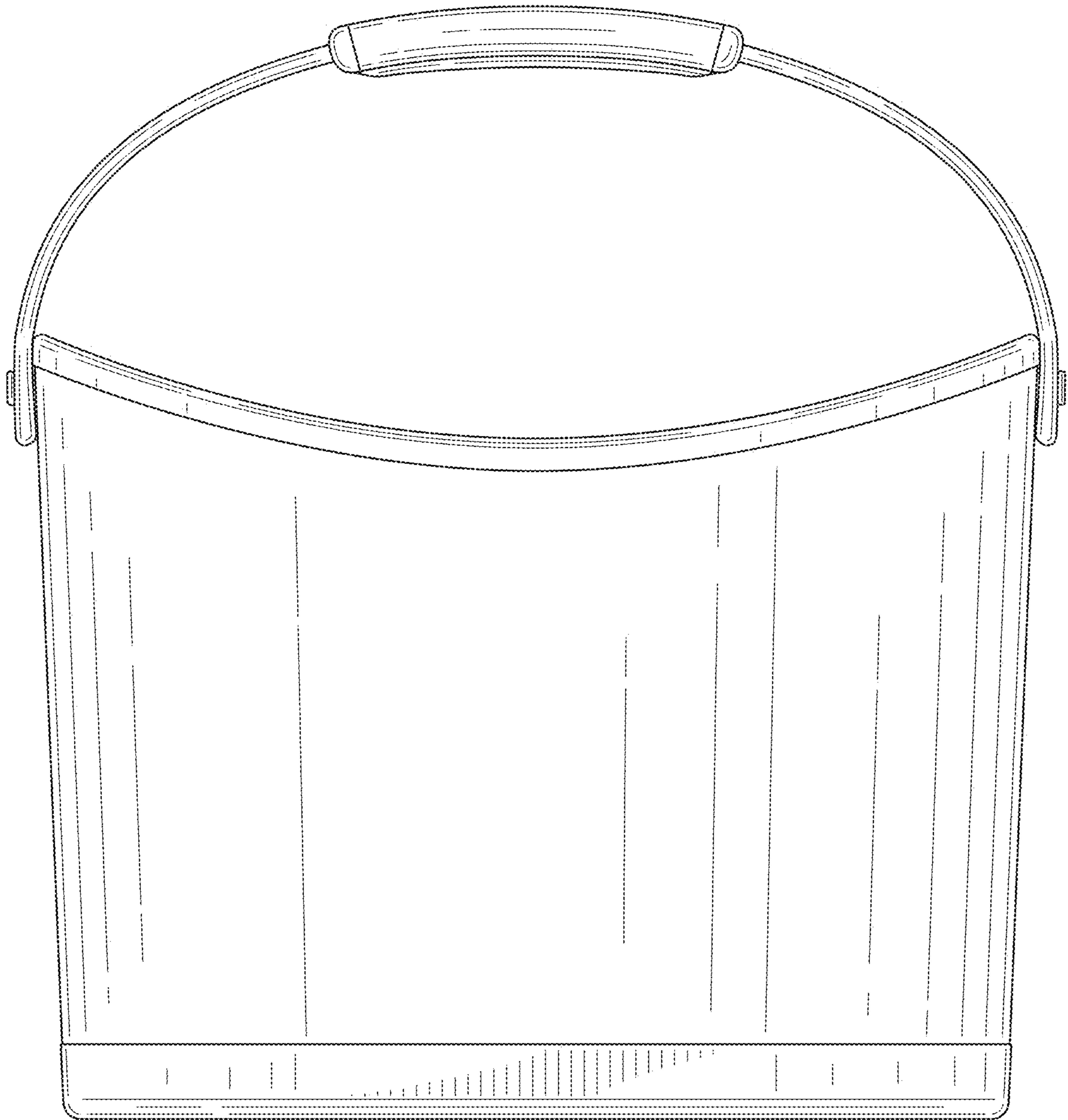

FIG. 3

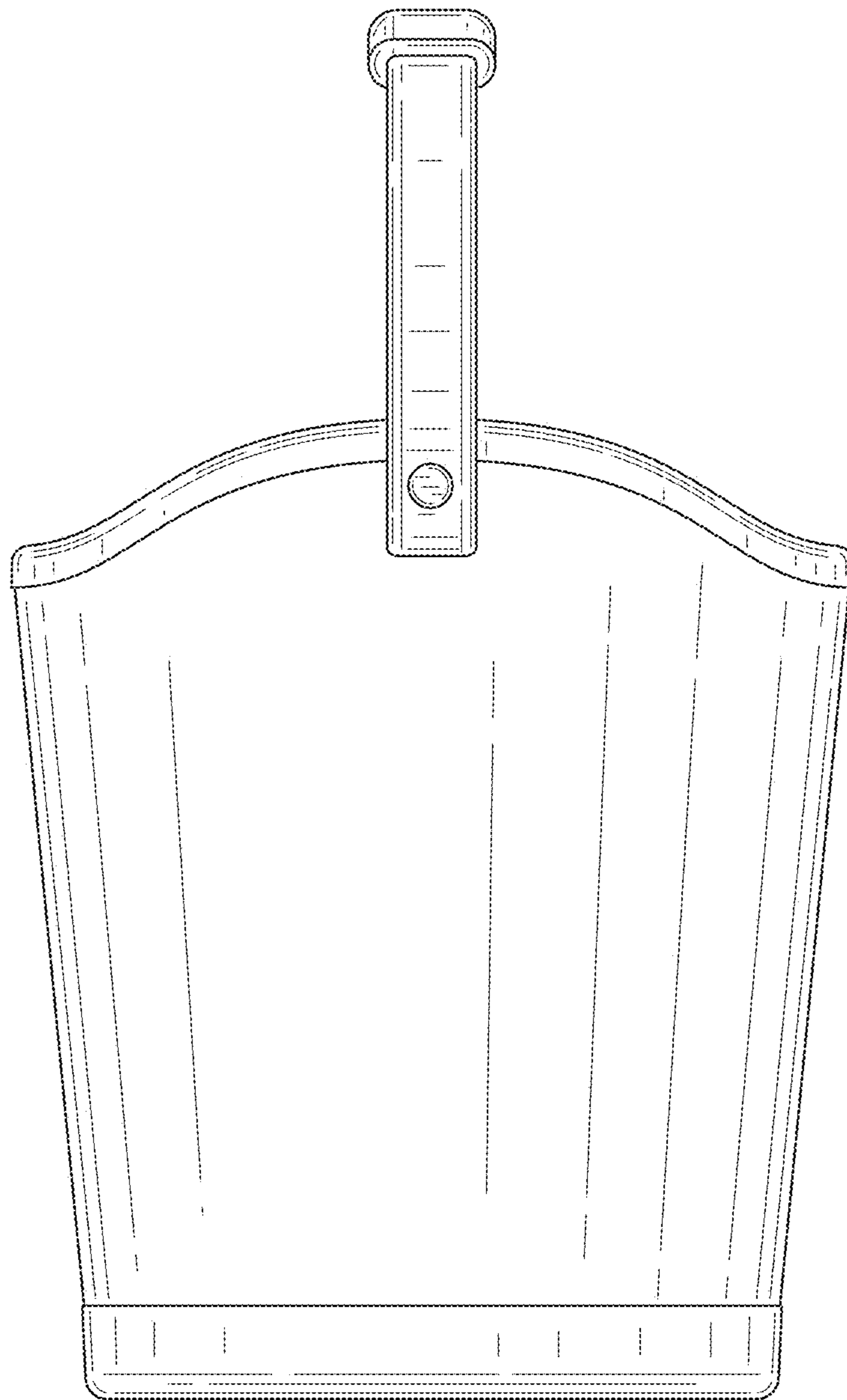

FIG. 4

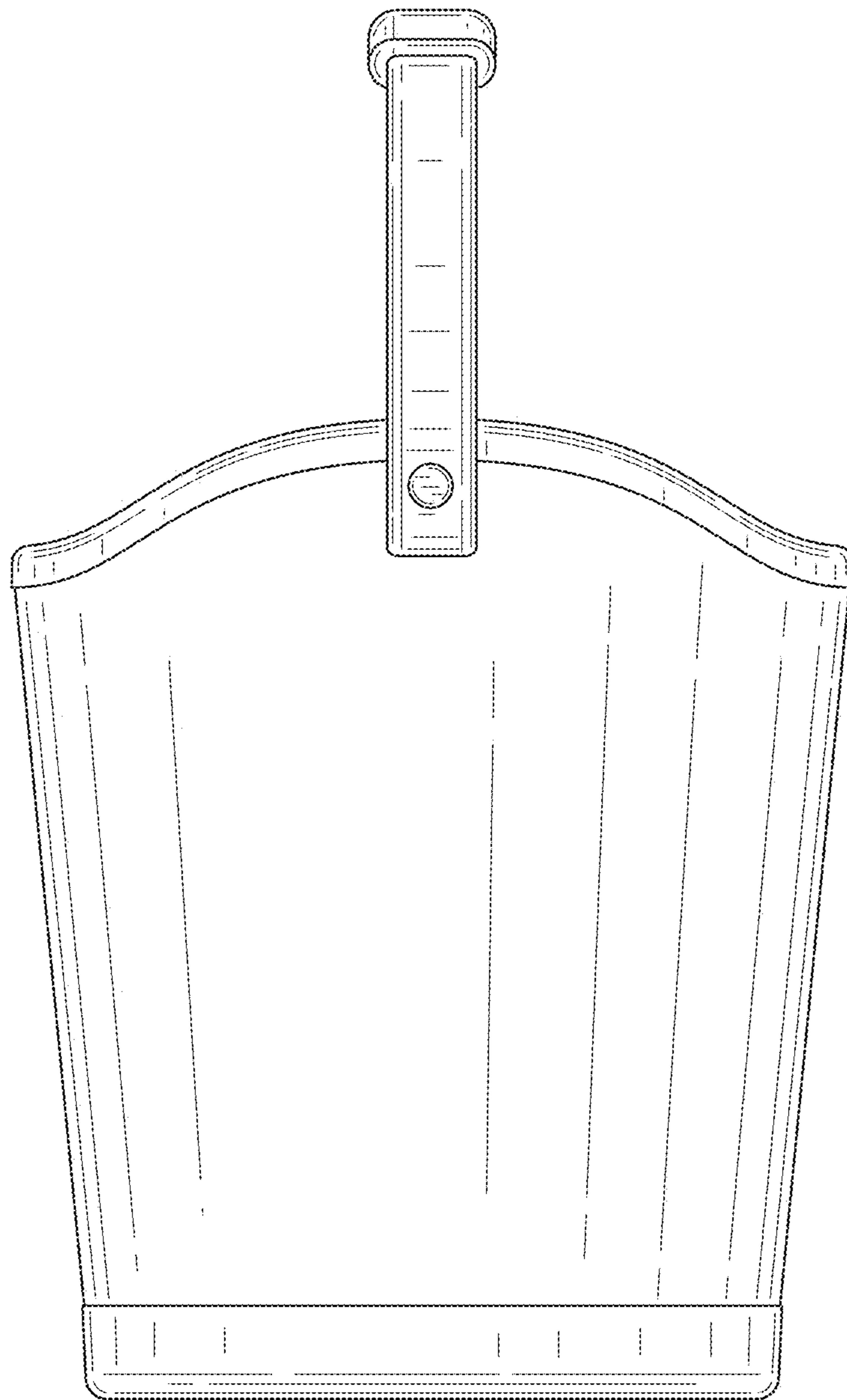

FIG. 5

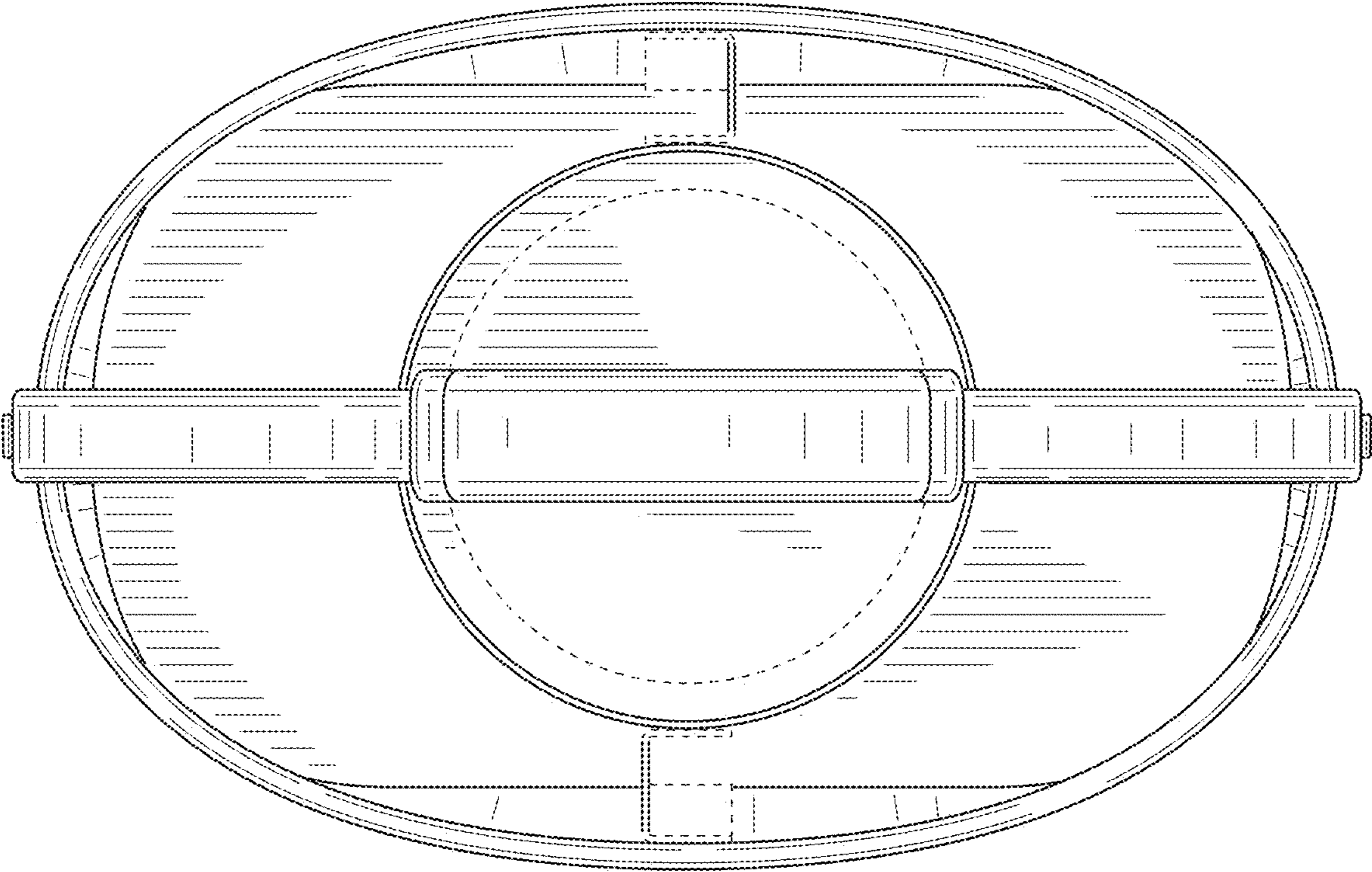

FIG. 6

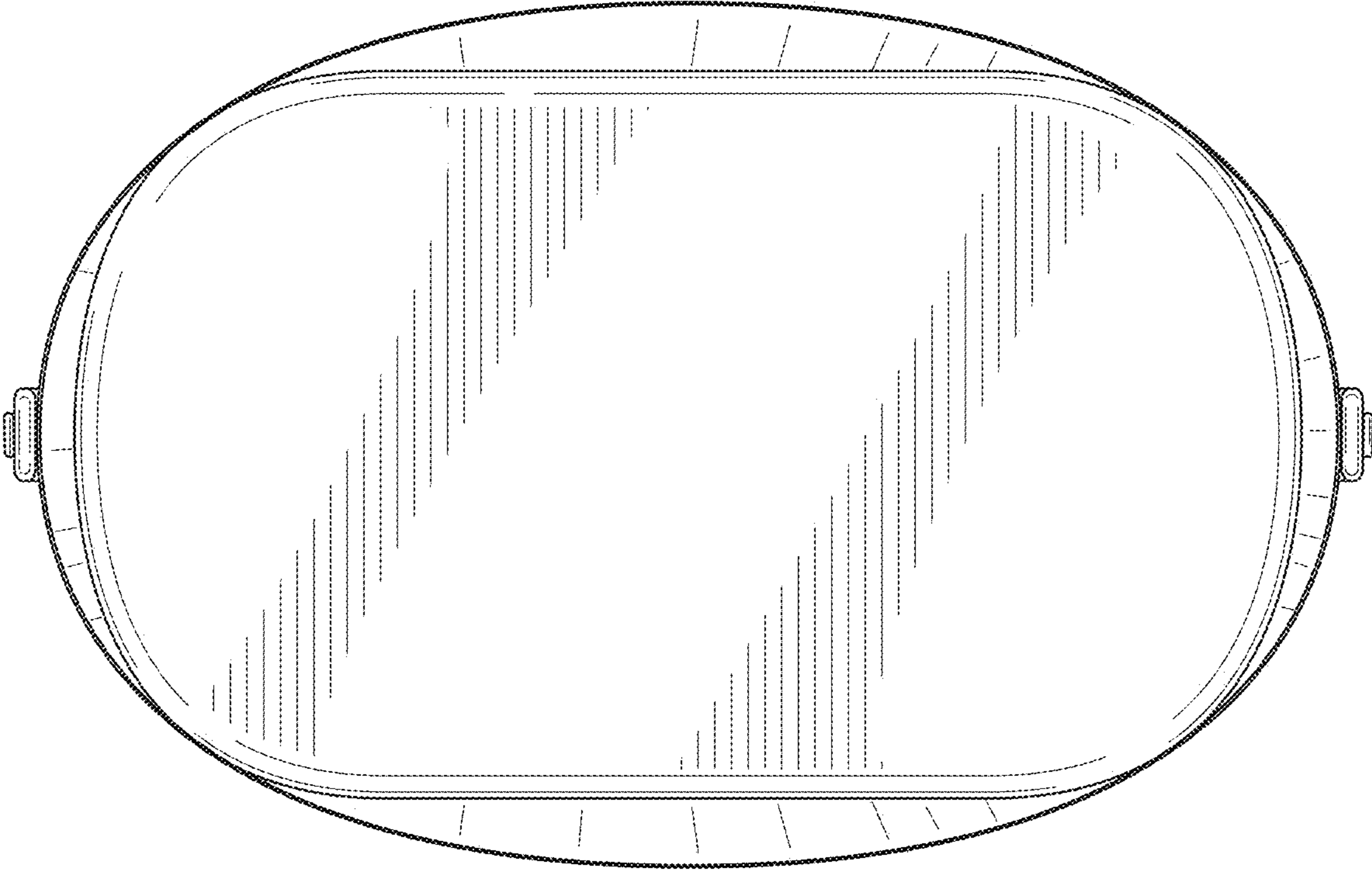

FIG. 7

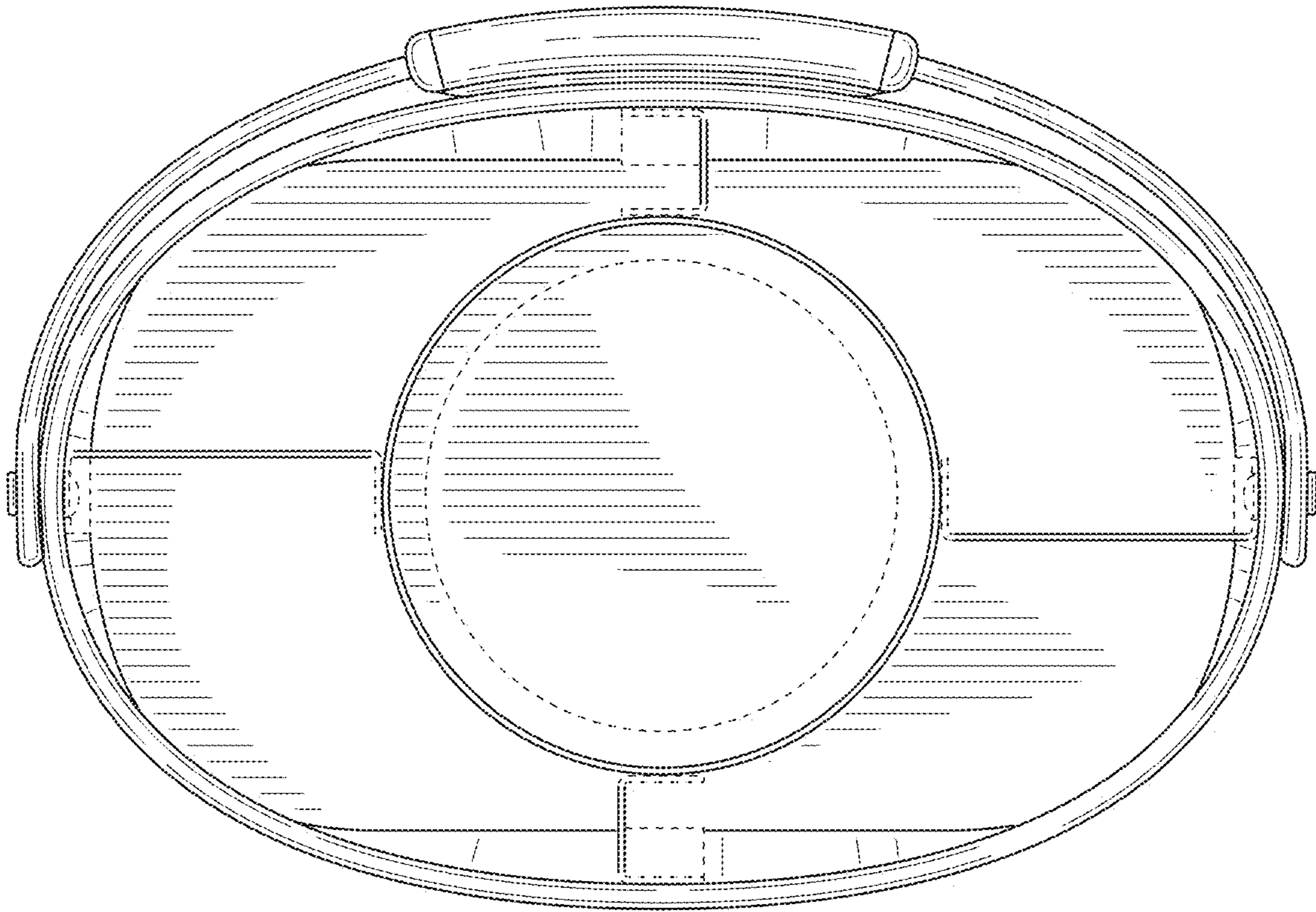

FIG. 8

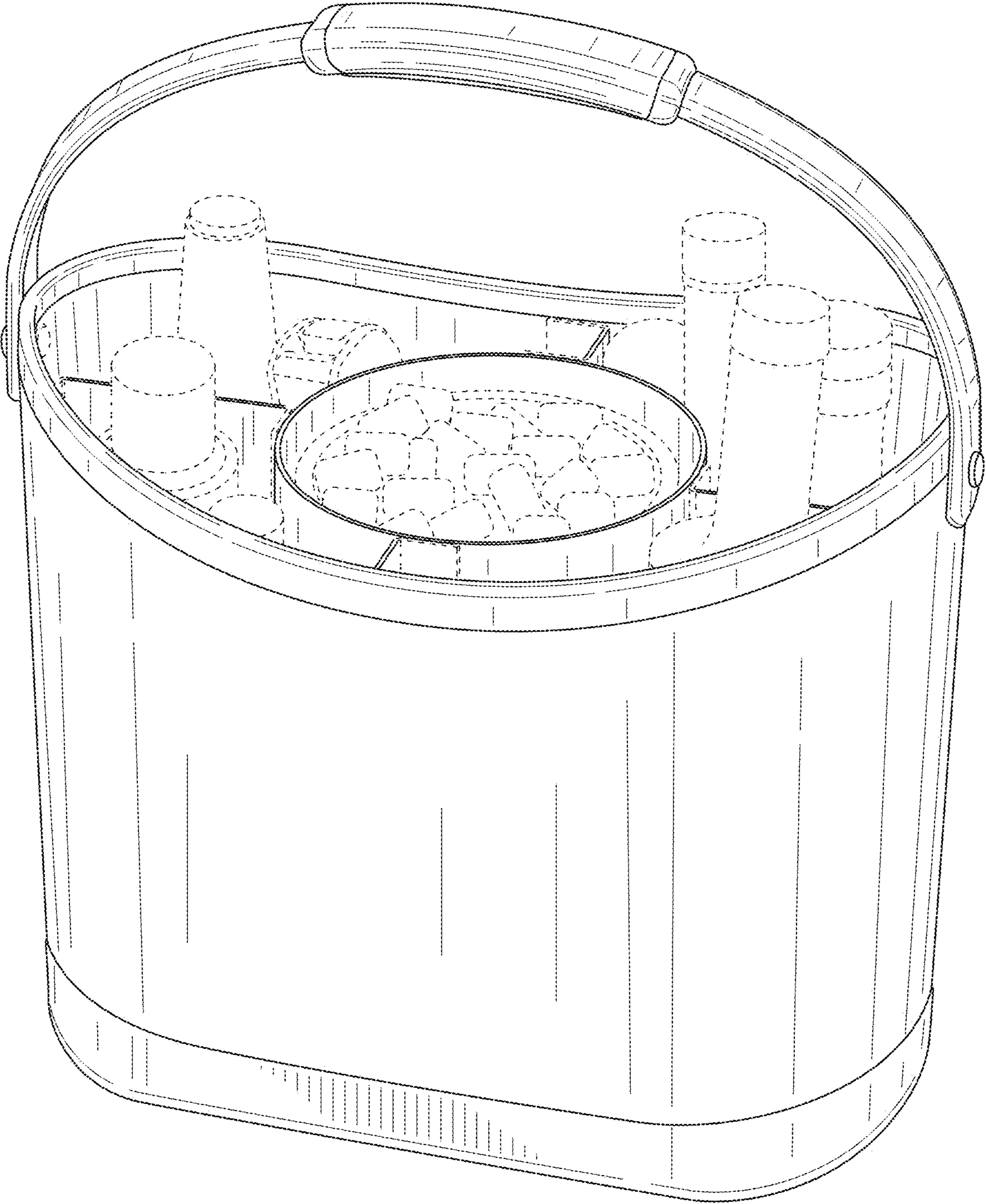

FIG. 9