



US00D912676S

(12) **United States Design Patent** (10) **Patent No.:** **US D912,676 S**
Wright et al. (45) **Date of Patent:** **** Mar. 9, 2021**

(54) **WATCH CASE**

(71) Applicant: **CATALYST LIFESTYLE LIMITED,**
North Point (HK)

(72) Inventors: **Joshua Wright,** Hong Kong (CN);
June Lai, Hong Kong (CN)

(73) Assignee: **CATALYST LIFESTYLE LIMITED,**
Hong Kong (CN)

(**) Term: **15 Years**

(21) Appl. No.: **29/679,249**

(22) Filed: **Feb. 4, 2019**

(30) **Foreign Application Priority Data**

Nov. 16, 2018 (CN) 20183065634.6

(51) **LOC (13) Cl.** **14-02**

(52) **U.S. Cl.**
USPC **D14/440; D10/132**

(58) **Field of Classification Search**
USPC D10/30-39, 40-41, 65, 70, 97-98, 128,
D10/131-132; D11/3, 5, 94; D14/344,
D14/345, 440; D24/167, 186
CPC G04B 19/18; G04B 19/23; G04B 19/283;
G04B 37/05; G04B 37/081-087; A44C
5/00; A44C 5/0053; A44C 5/14; A44C
5/147; A44C 5/22; A44C 5/24; A45C
11/10; A45C 11/12; A45C 13/002; A45C
2011/001-003

See application file for complete search history.

(56) **References Cited**

U.S. PATENT DOCUMENTS

739,768 A	9/1903	Wood
1,195,299 A	8/1916	Wachter
1,205,217 A	11/1916	Solomon
1,986,328 A	1/1935	Dreyfus
2,136,625 A	11/1938	Lasko
2,392,787 A	1/1946	Edmond
D157,606 S	3/1950	Lachman

3,194,004 A	7/1965	Church
3,640,065 A	2/1972	Lederrey et al.
3,789,601 A	2/1974	Bergey
3,800,525 A	4/1974	Bergey
3,992,874 A	11/1976	Collins
4,062,181 A	12/1977	Zurcher
4,236,239 A	11/1980	Imgruth et al.
4,390,288 A	6/1983	Amoux
D278,685 S	5/1985	Suzuki et al.
D279,081 S	6/1985	Suzuki et al.
D283,014 S	3/1986	Suzuki et al.
D290,234 S	6/1987	Komatsu
D293,417 S	12/1987	Sakamaki
D299,028 S	12/1988	Hermann
5,206,841 A	4/1993	Boucheron
D341,092 S	11/1993	Wild
D351,799 S	10/1994	Bulgari
5,392,261 A	2/1995	Hsu
5,477,508 A	12/1995	Will
D386,094 S	11/1997	Ventrella
D396,647 S	8/1998	Sugisawa
6,068,119 A	5/2000	Derr et al.
6,267,236 B1	7/2001	Seok
D451,419 S *	12/2001	Tomimatsu D10/132
D453,298 S	2/2002	Yoshikawa et al.
6,349,824 B1	2/2002	Yamada
D465,163 S	11/2002	Bodino
6,655,831 B1	12/2003	Rutheux
6,659,274 B2	12/2003	Enners
6,698,608 B2	3/2004	Parker et al.
D507,975 S	8/2005	Dreyfuss
D517,430 S	3/2006	TerMeer et al.
D520,805 S	5/2006	Wright
D528,440 S	9/2006	Lovegrove
D528,441 S	9/2006	Burton
D528,928 S	9/2006	Burton
7,106,197 B2	9/2006	Gaiotto et al.
D531,524 S	11/2006	Behling
D539,671 S	4/2007	Lassigne
D564,367 S	3/2008	Molyneux
7,555,325 B2	6/2009	Goros
7,577,468 B2	8/2009	Begic et al.
7,594,576 B2	9/2009	Chen et al.
D603,827 S	11/2009	Tompkin et al.
7,613,386 B2	11/2009	Shimamura
7,630,746 B2	12/2009	Holmberg
D616,417 S	5/2010	Liao
7,708,457 B2	5/2010	Girardin et al.
7,933,122 B2	4/2011	Richardson et al.
D638,312 S	5/2011	Jacobs
D638,324 S	5/2011	Tang
7,946,758 B2	5/2011	Mooring
D645,031 S	9/2011	Richardson et al.

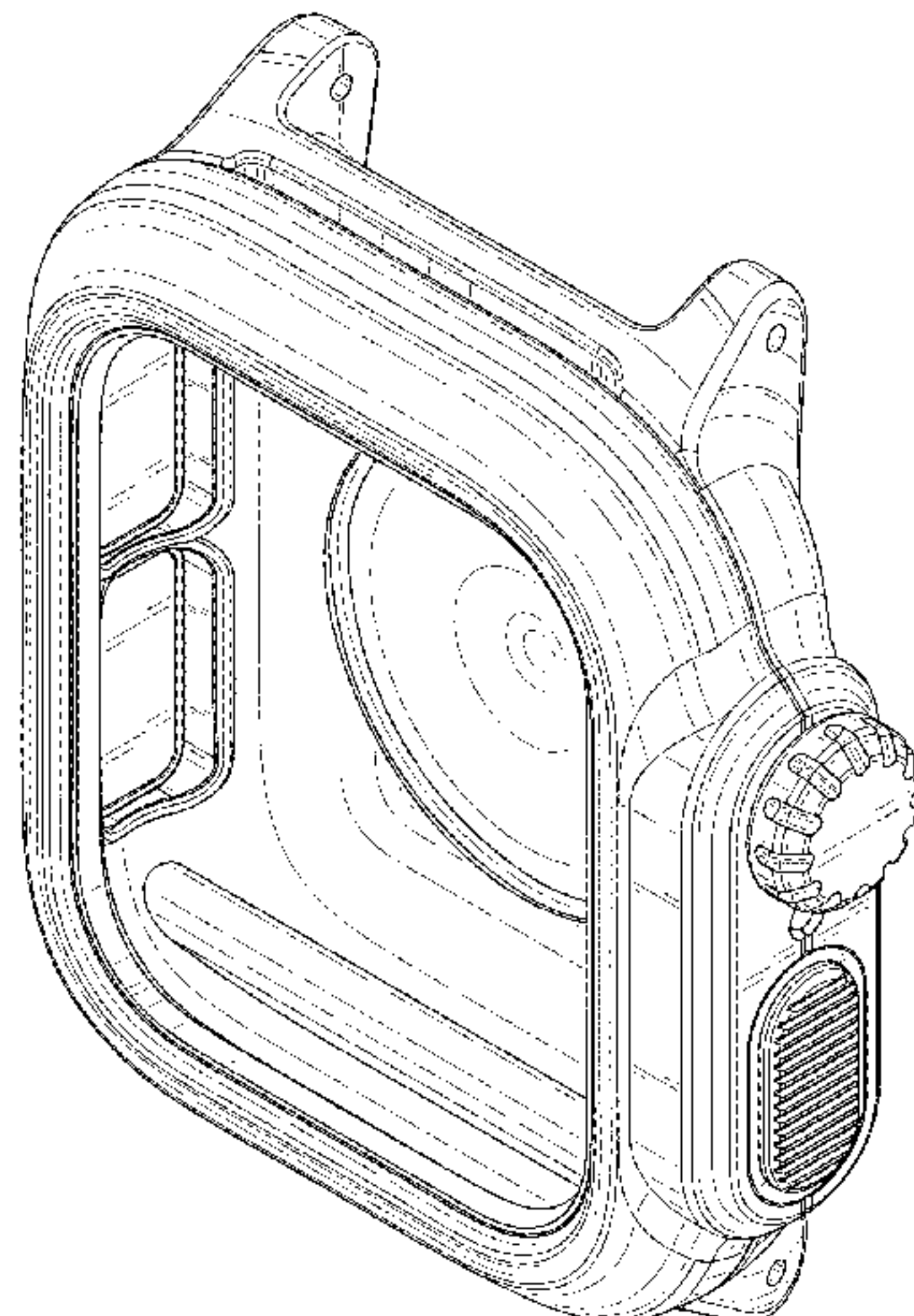

D657,262 S 4/2012 Pulli
D664,046 S 7/2012 Claessens
D666,924 S 9/2012 Ahlstrom
8,292,493 B2 10/2012 Mooring
D672,255 S 12/2012 Zanella et al.
D672,265 S 12/2012 Pulli
D673,477 S 1/2013 Szellos
8,342,325 B2 1/2013 Rayner
8,345,412 B2 1/2013 Maravilla et al.
D683,338 S 5/2013 Wilson et al.
D688,582 S 8/2013 Wilson
D688,967 S 9/2013 Wilson
D693,251 S 11/2013 Anderssen et al.
D699,701 S 2/2014 Kim
D709,057 S 7/2014 Wilson et al.
D709,869 S 7/2014 Witter et al.
8,787,009 B2 7/2014 Wilson et al.
D716,786 S 11/2014 Wilson et al.
D717,678 S 11/2014 Anderssen et al.
8,944,614 B2 2/2015 Parrill
8,955,678 B2 2/2015 Murphy et al.
8,967,437 B2 3/2015 Wilson
D727,194 S 4/2015 Wilson
9,004,329 B2 4/2015 Hsieh et al.
9,007,758 B2 4/2015 Wilson et al.
D729,218 S 5/2015 Wilson et al.
D737,159 S 8/2015 Akana et al.
9,101,184 B2 8/2015 Wilson
9,114,923 B2 8/2015 Richardson et al.
9,136,897 B2 9/2015 Hyneczek et al.
9,145,250 B2 9/2015 Richardson et al.
D741,726 S 10/2015 Akana et al.
9,155,368 B2 10/2015 Chang
D742,254 S 11/2015 Greusel et al.
D742,761 S 11/2015 Grazian et al.
D744,356 S 12/2015 Akana et al.
D745,421 S 12/2015 Akana et al.
9,223,346 B2 12/2015 Wilson
D746,707 S 1/2016 Akana et al.
D751,067 S 3/2016 Nousiainen
D751,550 S 3/2016 Solomon et al.
D751,558 S 3/2016 Lee
D752,044 S 3/2016 Akana et al.
D752,579 S 3/2016 Lee
D752,996 S 4/2016 Ebersold
D755,393 S * 5/2016 Amsler D24/167
D756,244 S 5/2016 Bastian et al.
D756,357 S 5/2016 Akana et al.
D756,824 S 5/2016 Akana et al.
D759,658 S 6/2016 Lai et al.
D759,725 S 6/2016 Akana et al.
9,386,932 B2 7/2016 Chatterjee et al.
D765,072 S 8/2016 Kwon
D766,904 S 9/2016 Jung
D766,905 S 9/2016 Lee
D766,906 S 9/2016 Kim
D767,573 S 9/2016 Kim
D768,612 S 10/2016 Wright et al.
D769,879 S * 10/2016 Kim D14/440
D771,504 S * 11/2016 Lai D10/30
D772,730 S * 11/2016 Lai D10/38
D780,740 S 3/2017 Kim
D786,879 S 5/2017 Kim
D790,517 S 6/2017 Akana et al.
D791,188 S 7/2017 Akana et al.
D795,089 S * 8/2017 Wright D10/32
D797,150 S 9/2017 Akana et al.
D797,809 S 9/2017 Akana et al.
D797,810 S 9/2017 Akana et al.
D798,744 S 10/2017 Wright et al.
D798,905 S 10/2017 Akana et al.
D799,344 S * 10/2017 Wright D10/30
D800,172 S 10/2017 Akana et al.
D800,700 S 10/2017 Bergman
D813,220 S * 3/2018 Wright D14/250
D819,622 S 6/2018 Wright et al.
D824,033 S 7/2018 Masuyama et al.
D839,753 S 2/2019 Domke et al.
D853,878 S * 7/2019 Wright D10/128

D867,179 S 11/2019 Akana et al.
2002/0065054 A1 5/2002 Humphreys et al.
2005/0116003 A1 6/2005 Butler et al.
2009/0080153 A1 3/2009 Richardson et al.
2009/0302799 A1 12/2009 Marquet et al.
2010/0061191 A1 3/2010 Chen
2012/0073093 A1 3/2012 Szellos
2012/0074005 A1 3/2012 Johnson et al.
2012/0134244 A1 5/2012 Margaritelli
2013/0001263 A1 1/2013 Kai
2013/0222139 A1 8/2013 Gouge et al.
2014/0022875 A1 * 1/2014 Scioscia G04B 37/05
2014/0356495 A1 12/2014 Teuscher
2015/0137731 A1 5/2015 Kim
2015/0141096 A1 5/2015 Murphy et al.
2015/0214991 A1 7/2015 Ranchod et al.
2015/0296963 A1 10/2015 Byun et al.
2015/0319520 A1 11/2015 Richardson et al.
2016/0254836 A1 9/2016 Alsberg et al.
2017/0035156 A1 * 2/2017 Wright A44C 5/0007
2017/0248922 A1 8/2017 Hyneczek

FOREIGN PATENT DOCUMENTS

CH	218928	A	1/1942
CH	343949	A	12/1959
CH	690870	A5	2/2001
CN	203119956	U	8/2013
CN	203708299	U	7/2014
CN	204190798	U	3/2015
CN	204305125	U	4/2015
DE	322169	C	11/1951
JP	8046371	A	2/1996
JP	9023072	A	1/1997
JP	3044740	U	1/1998
JP	10079582	A	3/1998
JP	11231970	A	8/1999
JP	11231973	A	8/1999
JP	11284358	A	10/1999
JP	2000125916	A	5/2000
JP	2006064762	A	3/2006
TW	D168277		6/2015
WO	9967889	A1	12/1999
WO	03041288	A2	5/2003
WO	2014019030	A1	2/2014

OTHER PUBLICATIONS

Catalyst 330ft Waterproof Case for Apple Watch Series 5 44mm | posted at amazon.com Jan. 2019 [online]. ©1996-2020, Amazon.com, Inc [retrieved Jun. 2, 2020] from Internet: <<https://www.amazon.com/Catalyst-Waterproof-Silicone-Resistant-Protective/dp/B07KRZNF59>> (Year: 2019).*

Catalyst Drop Case for Apple Watch / posted at macobserver.com May 2018 [online][site visited Jul. 17, 2018]. Available from internet: <<https://www.macobserver.com/cool-stuff-found/catalyst-drop-case-apple-watch-sports-band/>> (Year: 2018).
<https://www.amazon.com/Actionproof-Apple-Watch-Case-42mm>, Jan. 9, 2018.
<https://www.amazon.com/Caseology-Rugged-Protective-Resistant-Bumper>, Jan. 9, 2018.
<https://www.amazon.com/LUVVITT-Performance-FLuoroelastomer-Fiexible-Editions>, Jan. 9, 2018.
<https://www.amazon.com/OULUOQI-Shock-proof-Shatter-resistant-Protector-iwatch>, Jan. 9, 2018.
<https://www.amazon.com/Speck-Products-CandyShell-Apple-Watch>, Jan. 9, 2018.
<https://www.amazon.com/Spigen-Extreme-Protection-Protector-Original>, Jan. 9, 2018.
<https://www.amazon.com/UMTELE-Rugged-Scratch-Resistant-Protective>, Jan. 9, 2018.
<https://www.amazon.com/iitee-Universal-Rugged-Protective-iWatch>, Jan. 9, 2018.

Watch Case / Catalyst Case for Apple Watch / Catalyst, posted at catalystillifestyle.com, posting dale N/A, © 2016 catalystillifestyle.

com, [online], [site visited Jun. 24, 2016], Available from Internet <http://www.catalystlifestyle.com/collections/calalyst-case-for-apple-watch/products/calalyst-apple-watch-42mm>.

* cited by examiner

Primary Examiner — Katherine Glennon
(74) *Attorney, Agent, or Firm* — Dinsmore & Shohl LLP

(57) **CLAIM**

The ornamental design for a watch case, as shown and described.

DESCRIPTION

FIG. 1 is a perspective view including a front, an end, and a side of a first embodiment of a watch case;
FIG. 2 is an elevation view of the front of the watch case of FIG. 1;
FIG. 3 is an elevation view of a rear of the watch case of FIG. 1;
FIG. 4 is an elevation view of a side of the watch case of FIG. 1;

FIG. 5 is an elevation view of an opposite side of the watch case of FIG. 1;
FIG. 6 is an elevation view of an end of the watch case of FIG. 1;
FIG. 7 is an elevation view of an opposite end of the watch case of FIG. 1;
FIG. 8 is a perspective view including a front, an end, and a side of a second embodiment of the watch case;
FIG. 9 is an elevation view of the front of the watch case of FIG. 8;
FIG. 10 is an elevation view of a rear of the watch case of FIG. 8;
FIG. 11 is an elevation view of a side of the watch case of FIG. 8;
FIG. 12 is an elevation view of an opposite side of the watch case of FIG. 8;
FIG. 13 is an elevation view of an end of the watch case of FIG. 8; and,
FIG. 14 is an elevation view of an opposite end of the watch case of FIG. 8.
The broken lines show portions of the watch case that form no part of the claimed design.

1 Claim, 10 Drawing Sheets

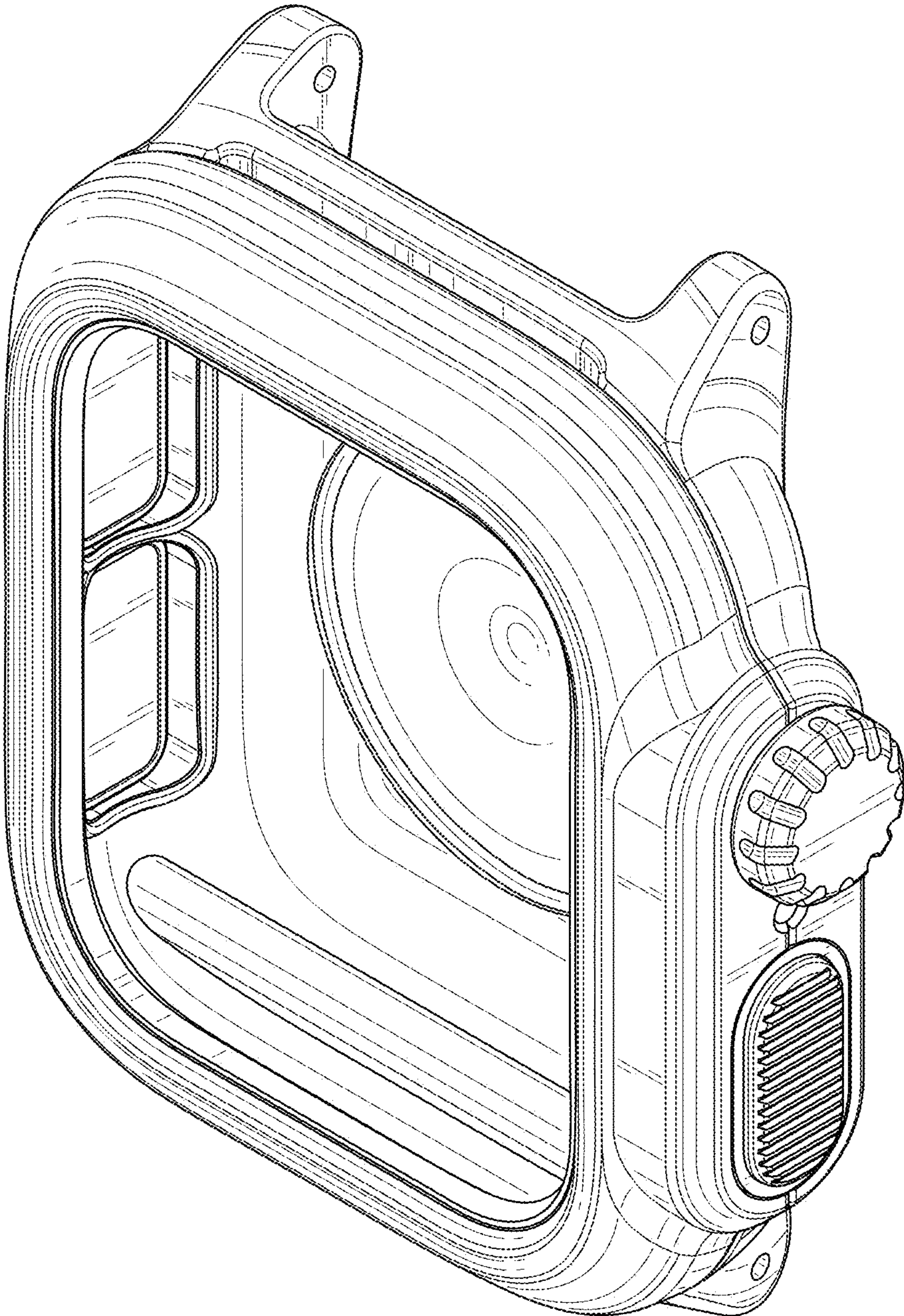

FIG. 1

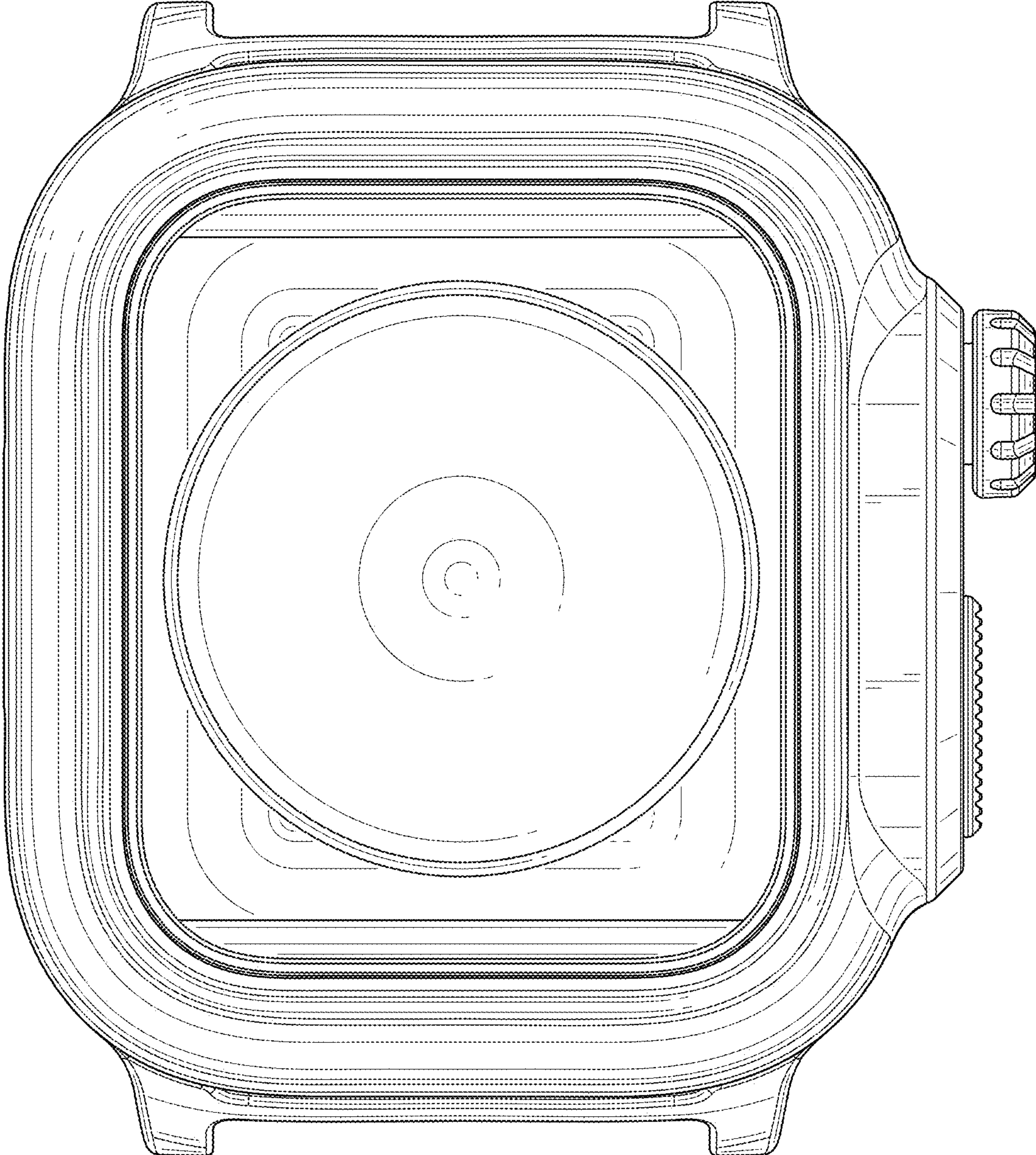

FIG. 2

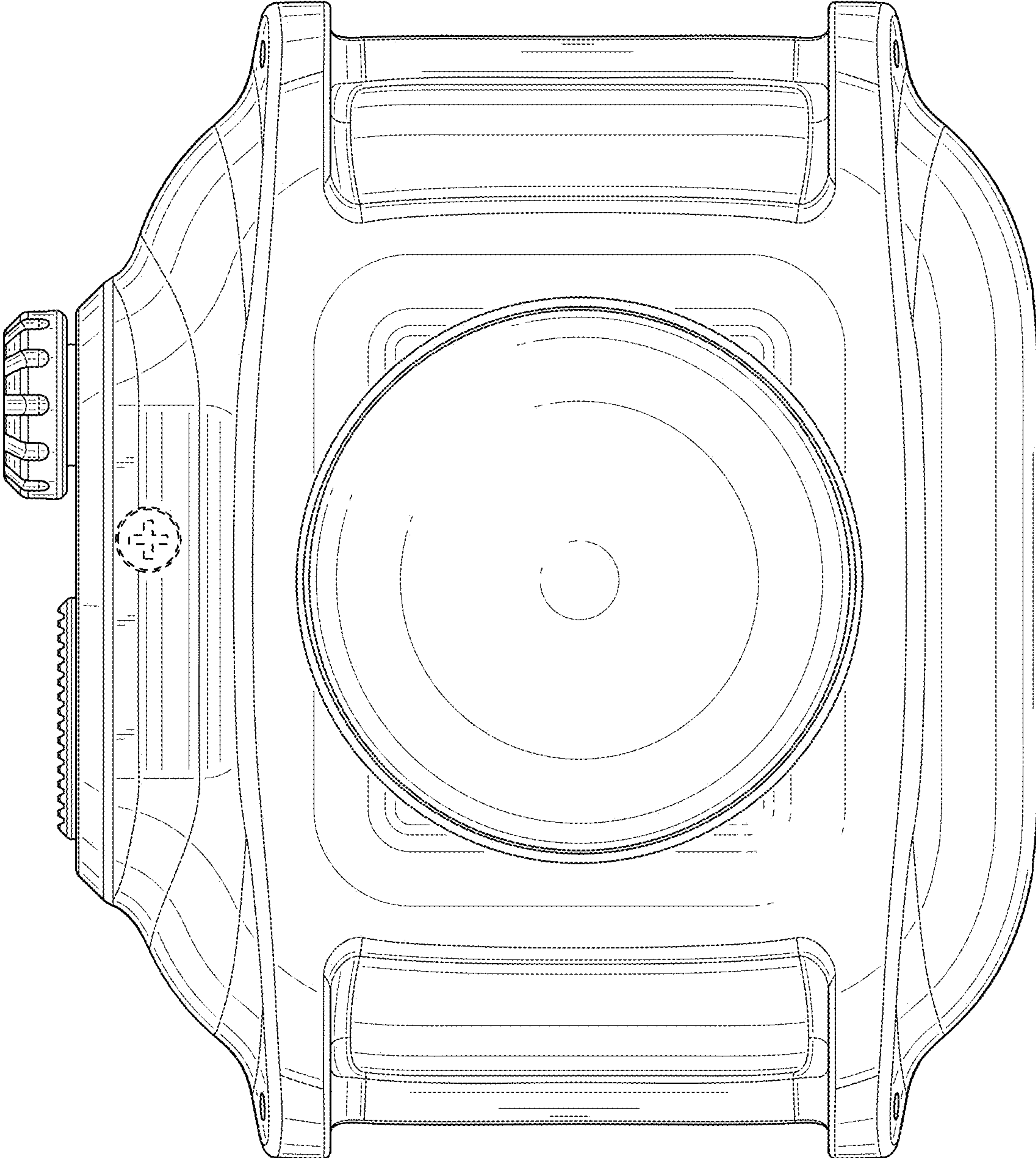

FIG. 3

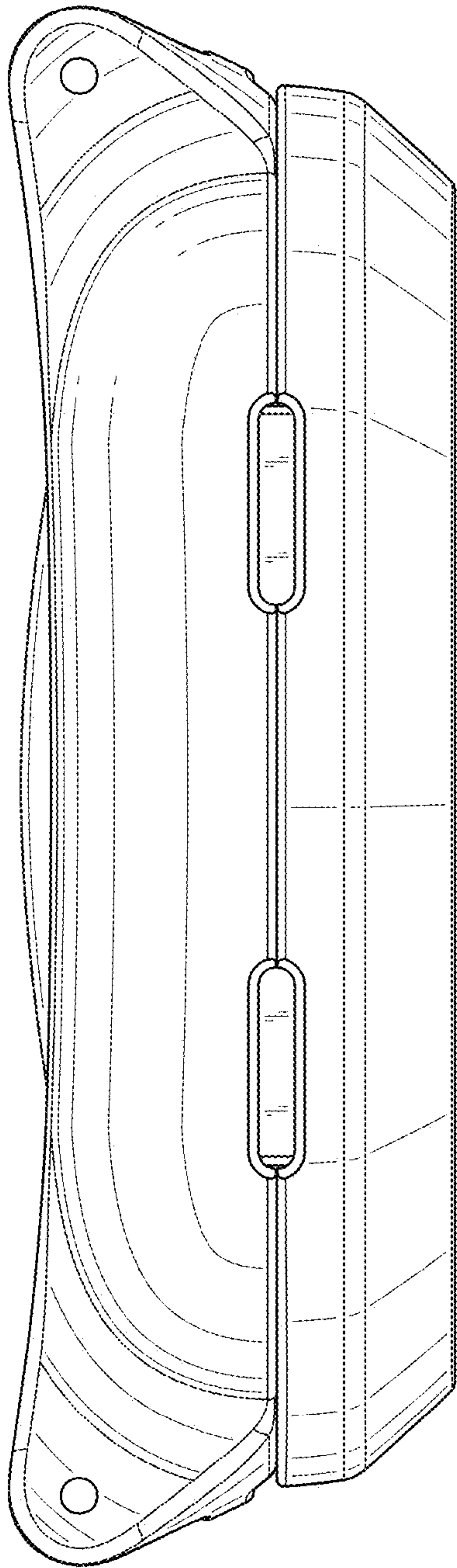

FIG. 4

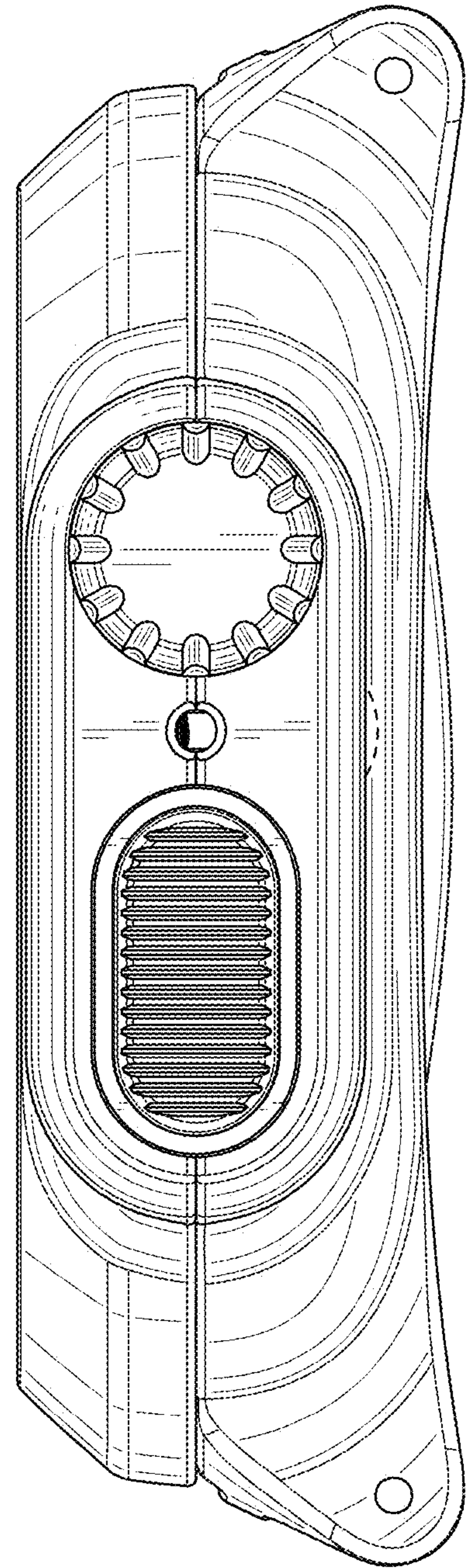

FIG. 5

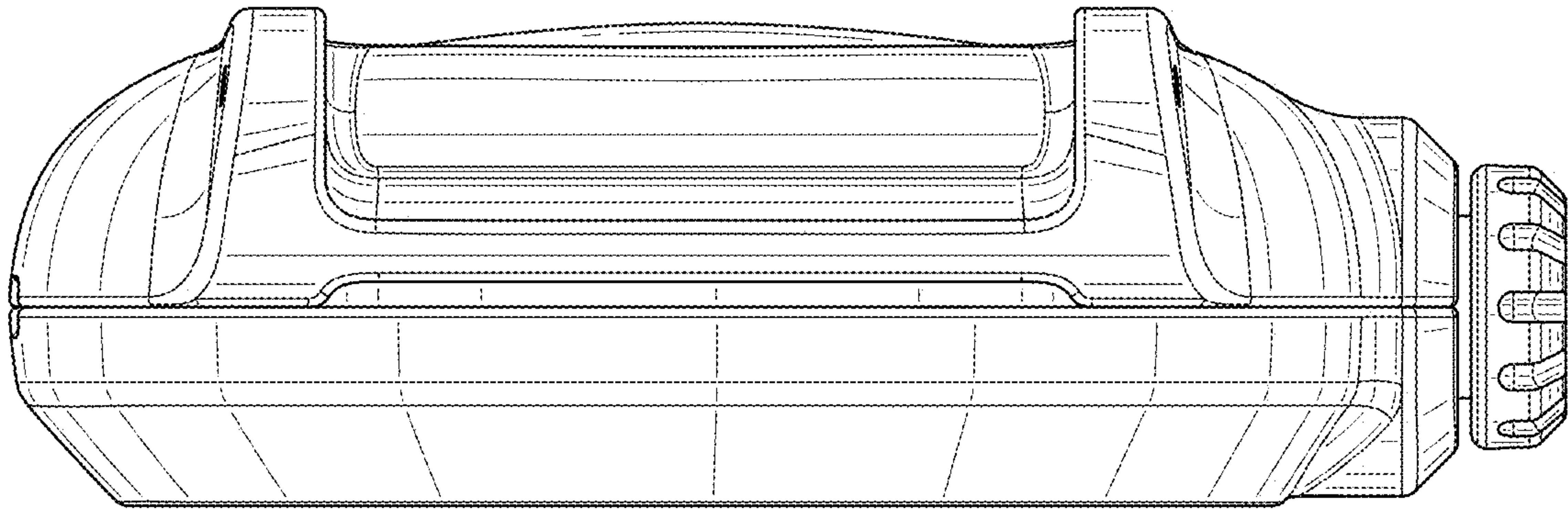

FIG. 6

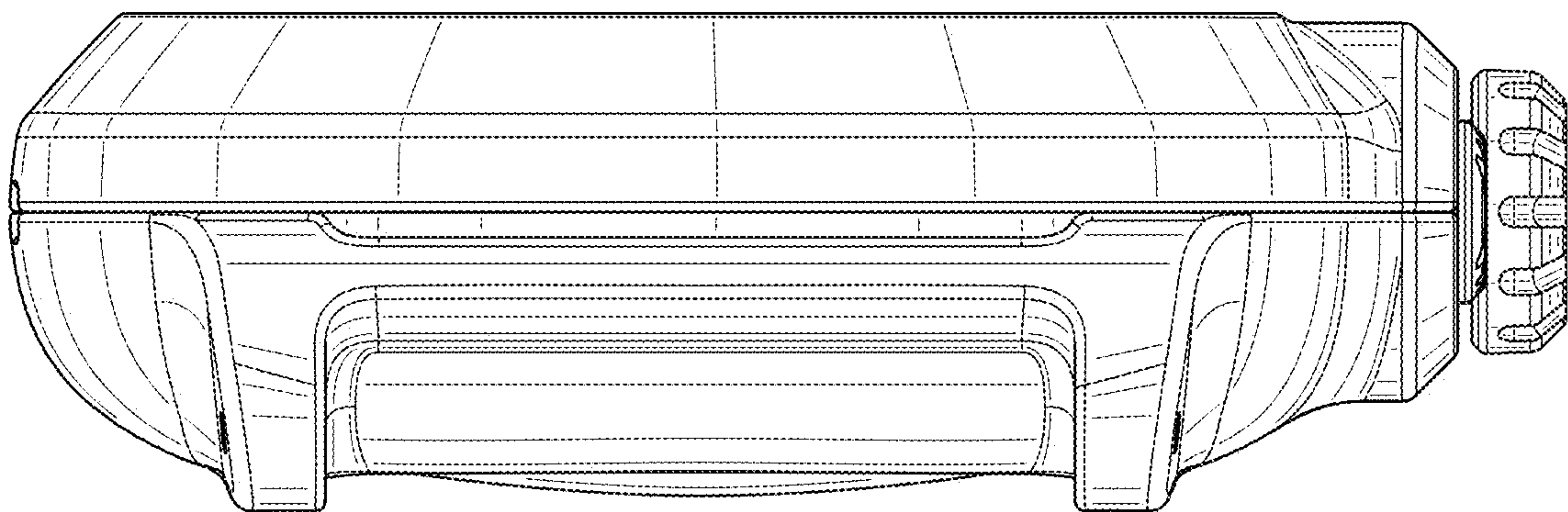

FIG. 7

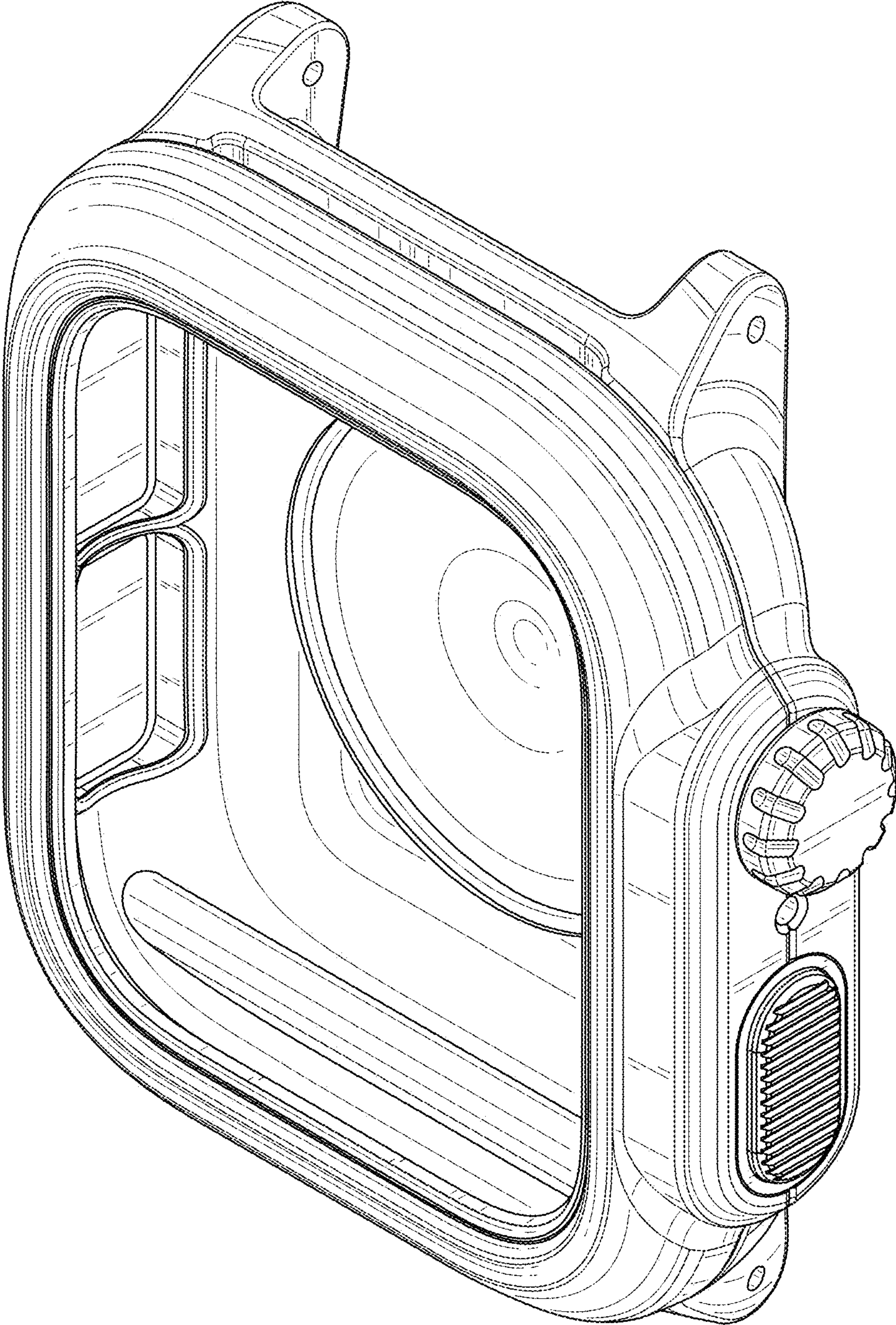

FIG. 8

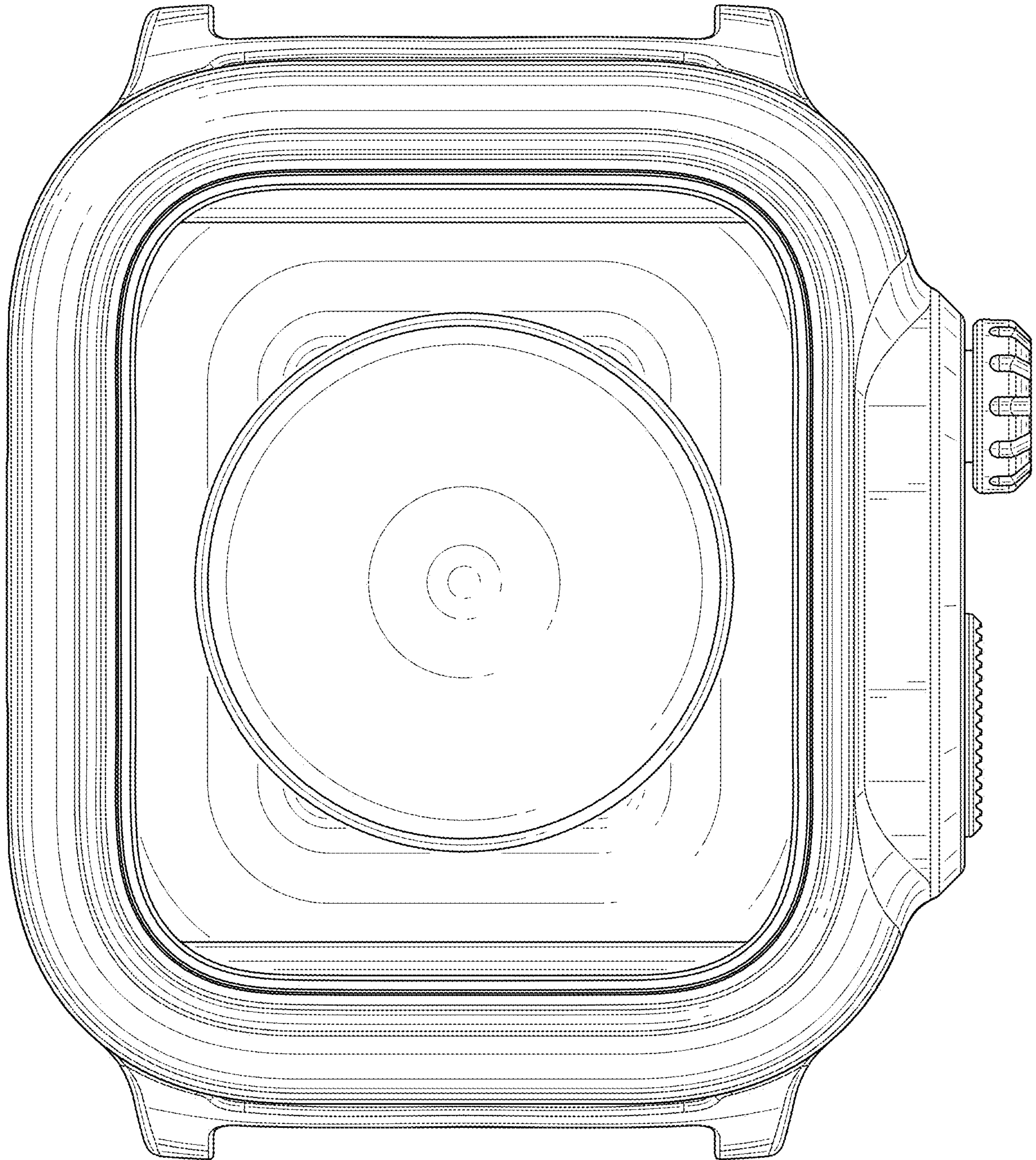

FIG. 9

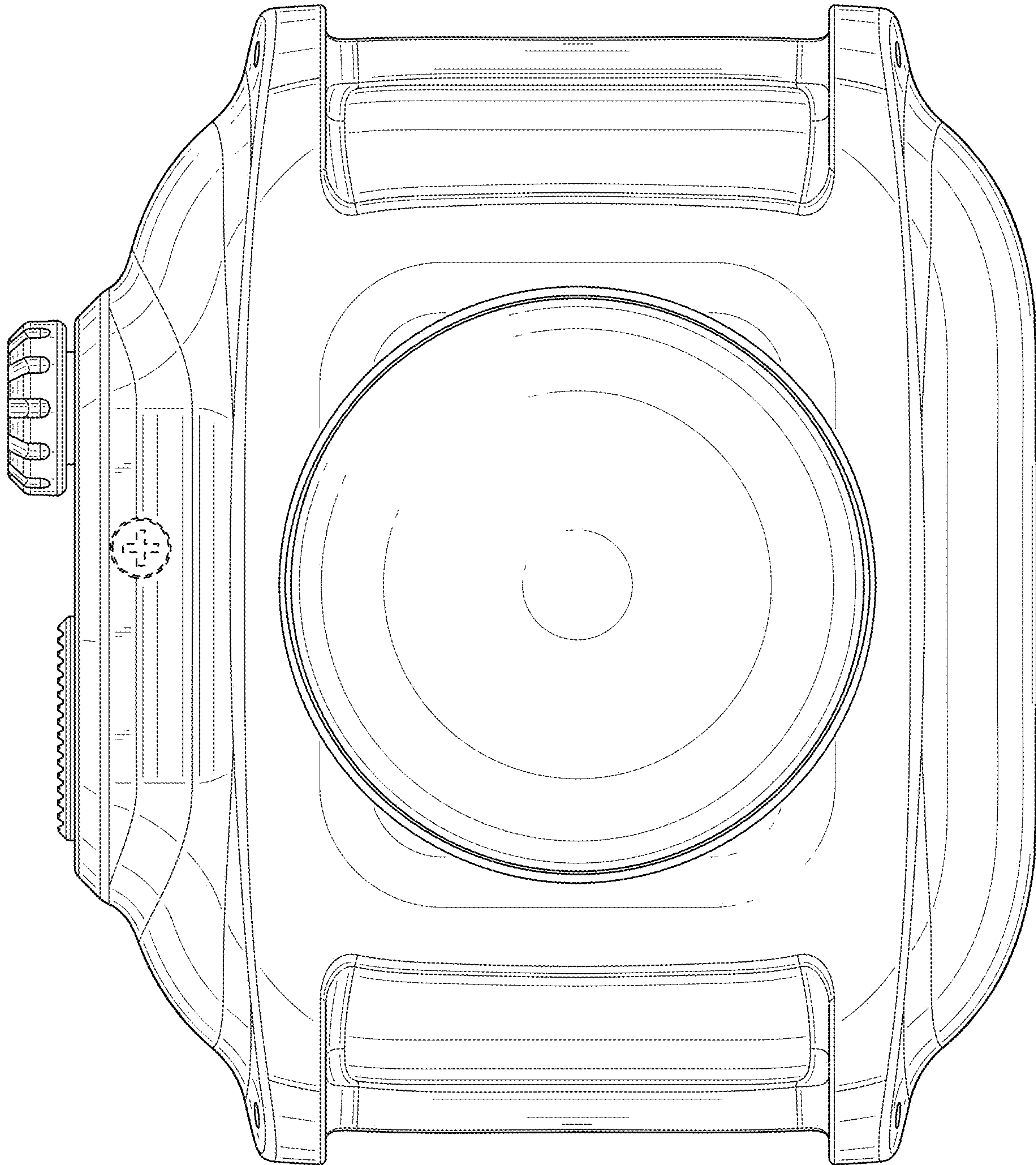

FIG. 10

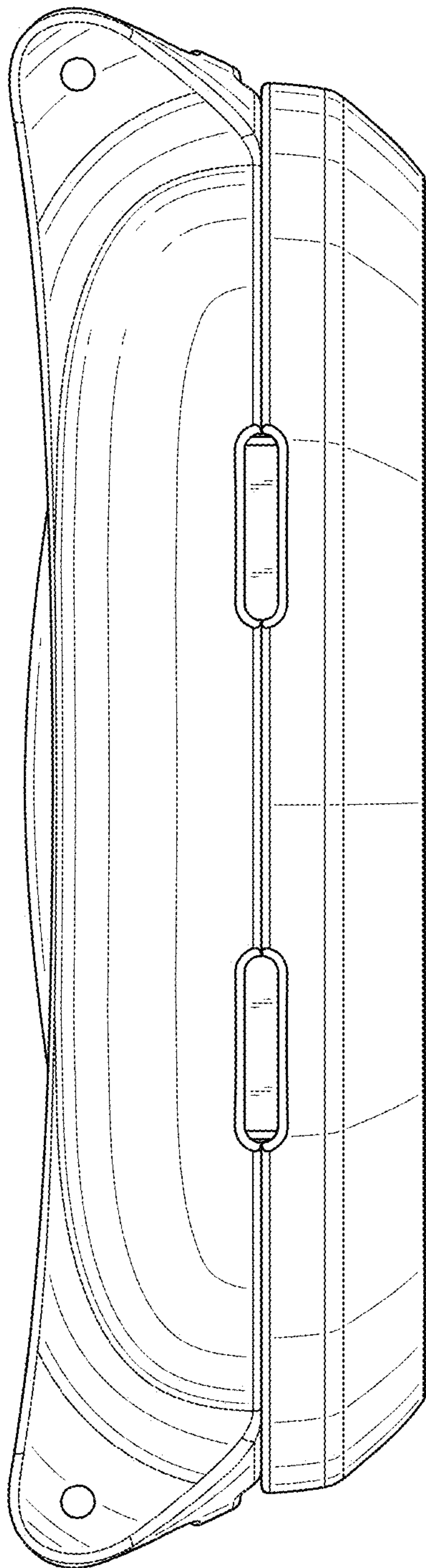

FIG. 11

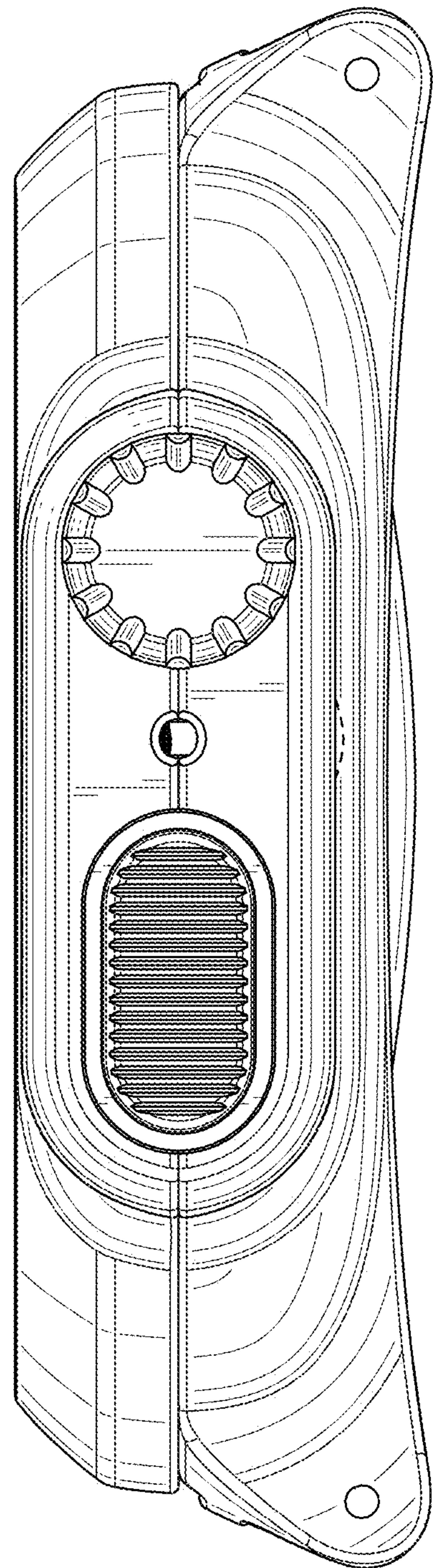

FIG. 12

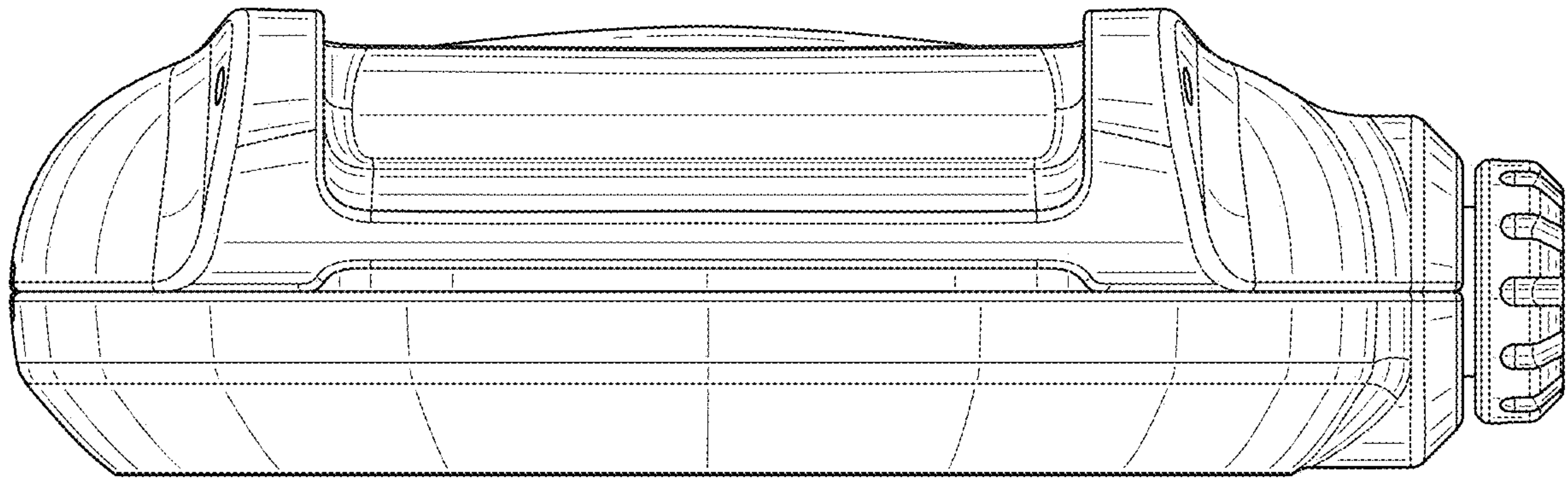

FIG. 13

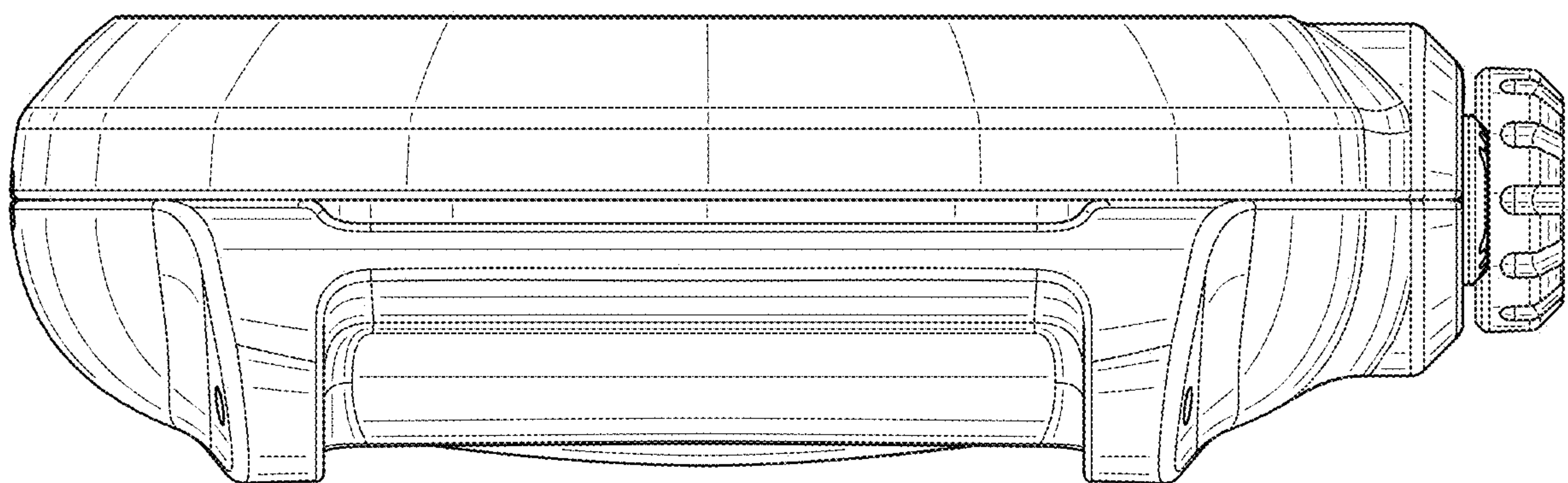

FIG. 14