



US00D912563S

(12) **United States Design Patent** (10) **Patent No.:** **US D912,563 S**  
**Akana et al.** (45) **Date of Patent:** **\*\* Mar. 9, 2021**

(54) **BAND**

(71) Applicant: **Apple Inc.**, Cupertino, CA (US)

(72) Inventors: **Jody Akana**, San Francisco, CA (US);  
**Bartley K. Andre**, Palo Alto, CA (US);  
**Shota Aoyagi**, San Francisco, CA (US);  
**Anthony Michael Ashcroft**, San Francisco, CA (US);  
**Jeremy Bataillou**, San Francisco, CA (US);  
**Daniel J. Coster**, San Francisco, CA (US);  
**Daniele De Iuliis**, San Francisco, CA (US);  
**M. Evans Hankey**, San Francisco, CA (US);  
**Julian Hoenig**, San Francisco, CA (US);  
**Richard P. Howarth**, San Francisco, CA (US);  
**Jonathan P. Ive**, San Francisco, CA (US);  
**Duncan Robert Kerr**, San Francisco, CA (US);  
**Marc A. Newson**, London (GB);  
**Matthew Dean Rohrbach**, San Francisco, CA (US);  
**Peter Russell-Clarke**, San Francisco, CA (US);  
**Benjamin Andrew Shaffer**, San Jose, CA (US);  
**Mikael Silvanto**, San Francisco, CA (US);  
**Christopher J. Stringer**, Woodside, CA (US);  
**Eugene Antony Whang**, San Francisco, CA (US);  
**Rico Zörkendörfer**, San Francisco, CA (US)

(73) Assignee: **Apple Inc.**, Cupertino, CA (US)

(\*\*) Term: **15 Years**

(21) Appl. No.: **29/716,290**

(22) Filed: **Dec. 9, 2019**

**Related U.S. Application Data**

(63) Continuation of application No. 29/595,106, filed on Feb. 24, 2017, now Pat. No. Des. 869,322, which is a continuation of application No. 29/519,674, filed on Mar. 6, 2015, now Pat. No. Des. 780,059, which is a

continuation of application No. 29/498,995, filed on Aug. 11, 2014, now Pat. No. Des. 724,469.

(51) **LOC (13) CI.** ..... **11-01**

(52) **U.S. CI.**  
USPC ..... **D11/3**

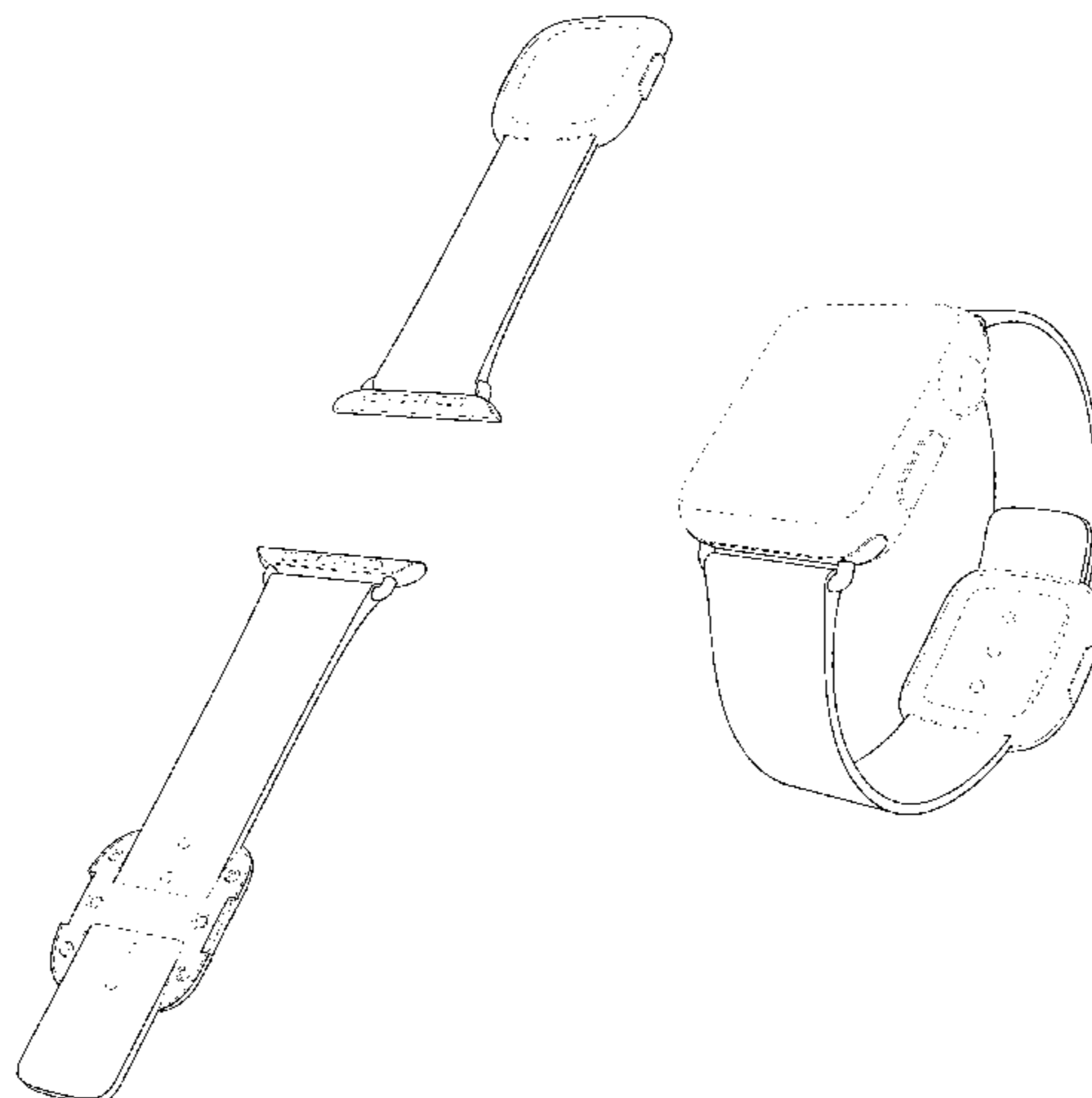
(58) **Field of Classification Search**  
USPC ..... D11/1-7, 16, 40-45, 47-50, 52-54,  
D11/56-58, 61, 63, 75-86; D3/207-211;  
D10/30, 32, 38, 70, 128; D14/344  
CPC ..... A44C 1/00; A44C 5/00; A44C 5/0007;  
A44C 5/02; A44C 7/00; A44C 7/002;  
A44C 7/003; A44C 7/004; A44C 7/005;  
A44C 7/006; A44C 7/007; A44C 7/008;  
A44C 7/009; A44C 15/00; A44C 25/00;  
A44C 25/001; A44C 25/002; A44C  
25/007

See application file for complete search history.

(56) **References Cited**

U.S. PATENT DOCUMENTS

482,289 A	9/1892	Ziegler	
505,473 A	9/1893	Mehring	
1,591,295 A	7/1926	Donaldson	
1,712,734 A	5/1929	Kraemer	
2,280,490 A	4/1942	Keltie	
D152,491 S	1/1949	Ostier	
2,467,204 A	4/1949	Greenberg	
D163,987 S	7/1951	Barre	
2,749,634 A	6/1956	Billett et al.	
2,954,622 A	10/1960	Moore	
3,030,686 A	4/1962	Burkhardt	
3,251,110 A	5/1966	Hedu	
3,422,507 A *	1/1969	Ikeda	A44C 5/22 D11/3
3,640,065 A	2/1972	Lederrey et al.	
3,665,565 A	5/1972	Kruger	
3,675,284 A	7/1972	Rieth	
3,889,411 A	6/1975	Laugherty et al.	
3,983,604 A	10/1976	Phillips	
D269,254 S	6/1983	Kishimoto	
4,470,174 A	9/1984	Rhea	
D287,471 S	12/1986	Sato et al.	
D299,718 S	2/1989	Steer et al.	
D305,422 S	1/1990	Steer et al.	
D320,566 S	10/1991	Ericson	
D331,020 S	11/1992	Ishii et al.	
D333,626 S	3/1993	Chang	





GB	2088761	2/2000
JP	H08336406 A	12/1996
JP	D1140196	4/2002
JP	D1263841	2/2006
JP	D1279761	8/2006
JP	D1296110	3/2007
JP	D1380179	2/2010
JP	D1494268	4/2014
JP	D1511746	11/2014
WO	WO-DM/012262-001	1/1989
WO	WO-DM/066491-004	3/2005
WO	WO-DM/072215	9/2009
WO	WO-DM/077452-004	6/2011
WO	WO-2013182397 A1	12/2013
WO	WO-2014135709 A2	9/2014

OTHER PUBLICATIONS

[Online]< <http://everydaydigitals.com/heres-what-i-think/21/apples-wearable-device-will-be-more-nike-fuel-band-than-pebble-watch>> Retrieved on Dec. 25, 2014.

[Online]< <http://www.computerworlduk.com/slideshow/mobile-wireless/3573389/the-many-looks-of-the-apple-watch/6/#content>> Retrieved on Dec. 25, 2014.

[Online] [http://i.ytimg.com/vi/Ab\\_oapZ8GpM/maxresdefault.jpg](http://i.ytimg.com/vi/Ab_oapZ8GpM/maxresdefault.jpg), accessed on Mar. 30, 2015.

[Online] <http://ttb.thetechblock.netdna-cdn.com/wp-content/uploads/2014/09/apple-watch-31.jpg>, accessed on Mar. 30, 2015.

Alvarez, Edgar, “Basis Peak to get its smartwatch-like features in December,” *engadget.com*,< <http://www.engadget.com/2014/11/20/basis-peak-new-features/>>, dated Nov. 20, 2014, accessed Dec. 15, 2014.

Cool Material, “Braun Square Digital Watch,”< <http://web.archive.org/web/20111125033014/http://coolmaterial.com/style/braun-square-digital-watch/>>, dated Nov. 25, 2011, accessed Dec. 18, 2014.

Emily, “Nixon—The Newton Digital,”< <http://www.freshnessmag.com/2009/09/08/nixon-the-newton-digital/>>, *freshnessmag.com*, dated Sep. 8, 2009, accessed Oct. 9, 2014.

etsy.com, “1 Set Silver End Cap Clasp—Findings Large Toggle Clasp End Caps Buckle Connector with Five Inside Loops for Jewelry Making 26mm,”< <http://www.etsy.com/listing/101269004/1-set-silver-end-cap-clasp-findings?ref=market>>, Listed on Aug. 29, 2014, accessed Oct. 9, 2014.

Fitbit, “Fitbit Surge™ Fitness Super Watch”< <https://www.fitbit.com/surge>>, accessed Dec. 15, 2014.

geekbuying.com, “Makibes unisex red led digital wrist watch with square case silicone watchband—white,”< <http://www.geekbuying.com/item/Unisex-Red-LED-Digital-Wrist-Watch-with-Square-Case-Silicone-Watchband---White-326443.html>>, accessed Oct. 9, 2014.

Hodinkee.com, “Apple iPod Nano Now Available With Mickey Mouse Dial, Also Cheesy, Mechanically Inaccurate Open-Worked Dial,”< <http://web.archive.org/web/20111006043916/http://www.hodinkee.com/blog/2011/10/5/apple-ipod-nano-now-available-with-mickey-mouse-dial-also-ch.html>>, dated Oct. 6, 2011, accessed Dec. 18, 2014.

Homego, “M6 Silver Smart Watch Cell Phone 1.54 inch Bluetooth 3.0 Dialer Outdoor Sports Pedometer,” *amazon.com*,< <http://www.amazon.com/Silver-Bluetooth-Dialer-Outdoor-Pedometer/dp/B00MQTBGK6>>, accessed Dec. 15, 2014.

Ikepod, “Original Ikepod Watch With GMT—Marc Newson Design,” *Watchbox.be*,< <http://www.watchbox.be/prod/Others-Watches/Marc%20Newson%20Design/item7165.htm#.VJLm2fAo5D8>>, accessed Dec. 17, 2014.

LG Life’s Good, “LG G Watch (W100),”< <http://www.lg.com/us/smart-watches/lg-W100-g-watch>>, accessed Dec. 18, 2014.

Metawatch, “Frame—Black (MW3005),”< <http://meta.watch/collections/smartwatch-all/products/frame-ss-black-leather>>, accessed Dec. 15, 2014.

Omate, “The TrueSmart™ is the world’s first standalone smartwatch 2.0 running on top of Android and OUI 2.0,”< <http://www.omate.com/product.html>>, accessed Dec. 15, 2014.

Pebble, “Pebble Smartwatch,” *getpebble.com*,< <https://getpebble.com/checkout/>>, accessed Dec. 15, 2014.

Samsung, “Galaxy Gear™ Live, Black SM-R3820ZKAXAR,”< <http://www.samsung.com/us/mobile/wearable-tech/SM-R3820ZKAXAR>>, accessed Dec. 15, 2014.

Samsung, “Samsung Gear S™, (Sprint), Black SM-R750PZKASPR,”< <http://www.samsung.com/us/mobile/wearable-tech/SM-R750PZKASPR>>, accessed Dec. 15, 2014.

Samsung, “Samsung Gear™ 2 Charcoal Black SM-R3800VSAXAR,”< <http://www.samsung.com/us/mobile/wearable-tech/SM-R3800VSAXAR>>, accessed Dec. 15, 2014.

Sony, “SmartWatch 3 SWR50,”< <http://www.sonymobile.com/us/products/smartwear/smartwatch-3-swr50/>>, accessed Dec. 15, 2014.

Sony, “SmartWatch,”< <http://www.sonymobile.com/us/products/accessories/smartwatch/>>, accessed Dec. 15, 2014.

Stables, James, “Clevercare smartwatch aims to help Alzheimer’s suffers and carers: Revamped Sony SmartWatch 2 designed for users that need care,” *Wearable News*,< <http://www.wearable.com/wearable-tech/clevercare-smartwatch-aims-to-help-alzheimers-suffers-and-carers-585>>, dated Dec. 15, 2014.

Team Luxe, “Collector’s Edition: Hermes Carre H Watch,” *Luxpresso*,< <http://luxpresso.com/news-couture/collectors-edition-hermes-carre-h-watch/2814>>, dated Jan. 10, 2011, accessed Dec. 18, 2014.

Ted Baker, “Ted Baker Men’s TE1054 Time Flies Contemporary Square Digital Case Watch,”< <http://www.amazon.com/Ted-Baker-TE1054-Contemporary-Digital/dp/B0045CRTYO%3FSubscriptionId%3DAKIAJ3U4YRIBWCGGKZ2A%26tag%3Dfrases365-20%26linkCode%3Dsp1%26camp%3D2025%26creative%3D165953%26creativeASIN%3DB0045CRTYO>>, accessed Oct. 9, 2014.

Velazco, Chris, “Asus ZenWatch review: subtle and stylish, with a few shortcomings,” *Engadget.com*,< <http://www.engadget.com/2014/12/11/asus-zenwatch-review/>>, dated Dec. 11, 2014, accessed Dec. 15, 2014.

Watches Infoniac.com, “Hermes Carre H Watch—Extremely Contemporary Design,”< <http://watches.infoniac.com/carre-h-watch-hermes.html>>, dated Aug. 13, 2010, accessed Dec. 18, 2014.

Watchismo, “Braun BN0042 Black Date Leather,”< <http://web.archive.org/web/20130815073830/http://www.watchismo.com/braun-bn0042bkbk.aspx>>, dated Aug. 15, 2013, accessed Dec. 18, 2014.

\* cited by examiner

*Primary Examiner* — Wendy L Arminio  
(74) *Attorney, Agent, or Firm* — Sterne, Kessler, Goldstein & Fox P.L.L.C.

(57) CLAIM

The ornamental design for a band, as shown and described.

DESCRIPTION

FIG. 1 is a bottom front perspective view of a band showing the claimed design;  
FIG. 2 is a bottom rear perspective view thereof;  
FIG. 3 is a front view thereof;  
FIG. 4 is a rear view thereof;  
FIG. 5 is a left side view thereof;  
FIG. 6 is a right side view thereof;  
FIG. 7 is a top view thereof;  
FIG. 8 is a bottom view thereof; and,  
FIG. 9 is a perspective view thereof in an environment in which it may be used.  
The broken lines in the figures show portions of the band and environment that form no part of the claimed design.

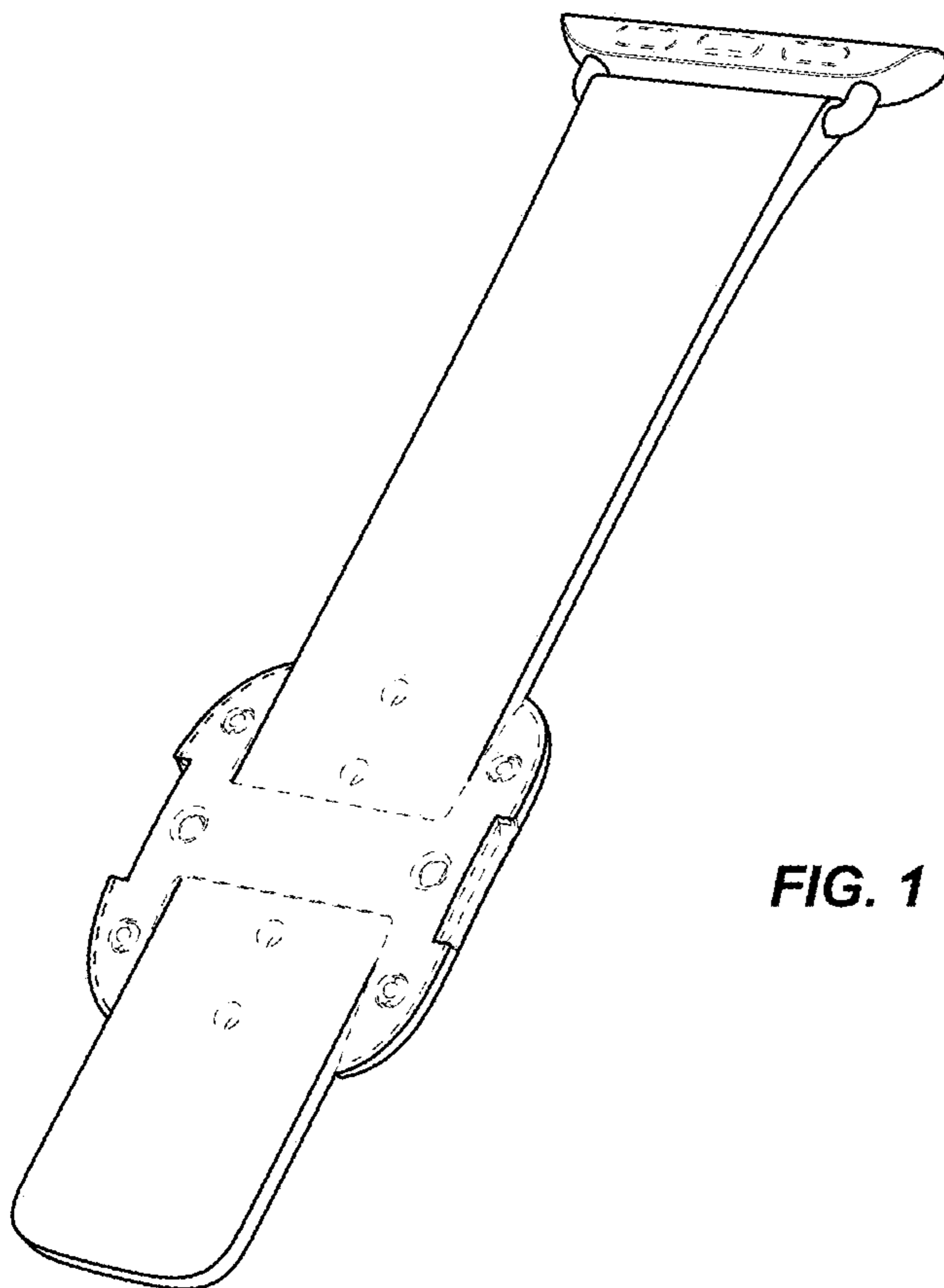
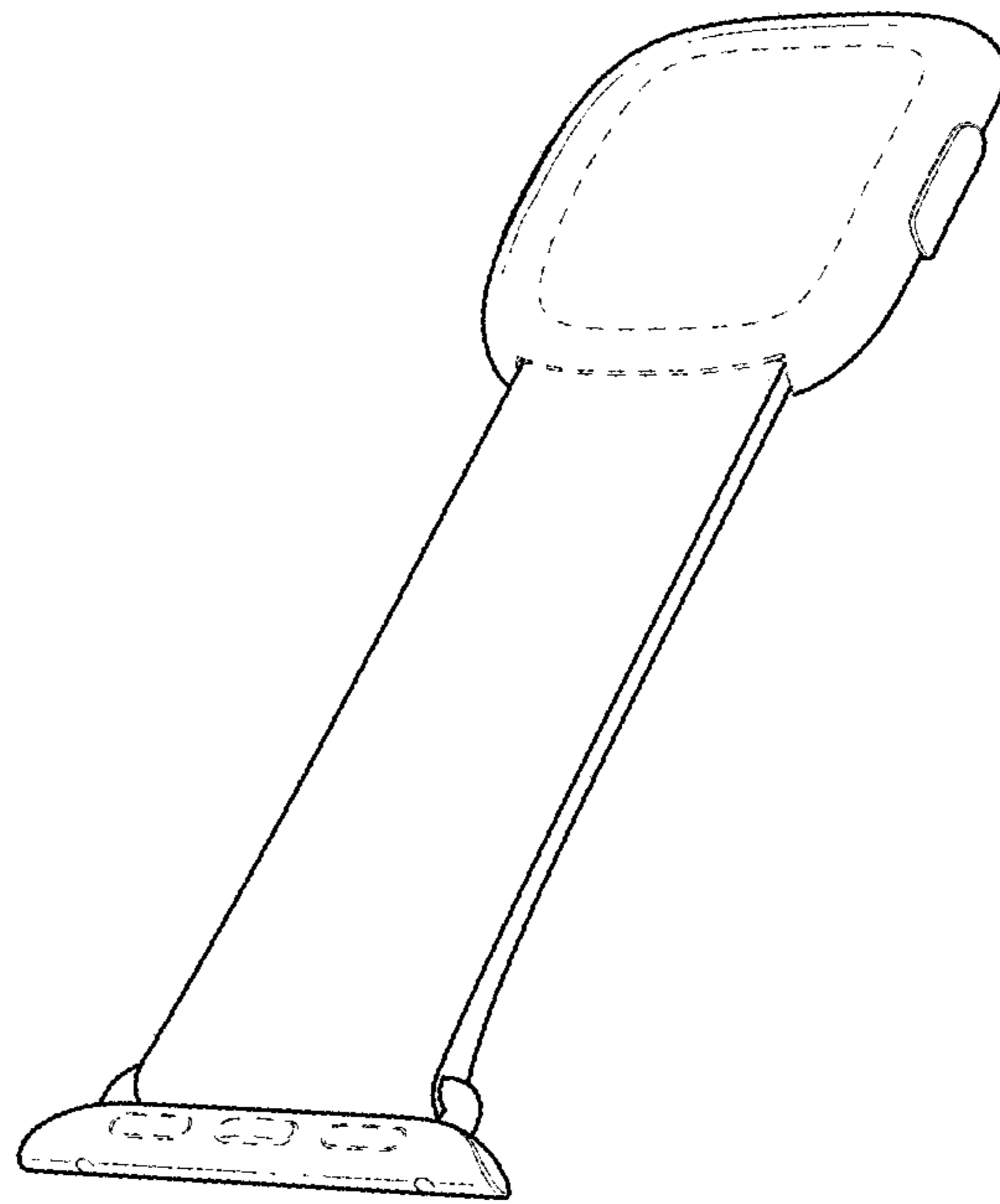


FIG. 1

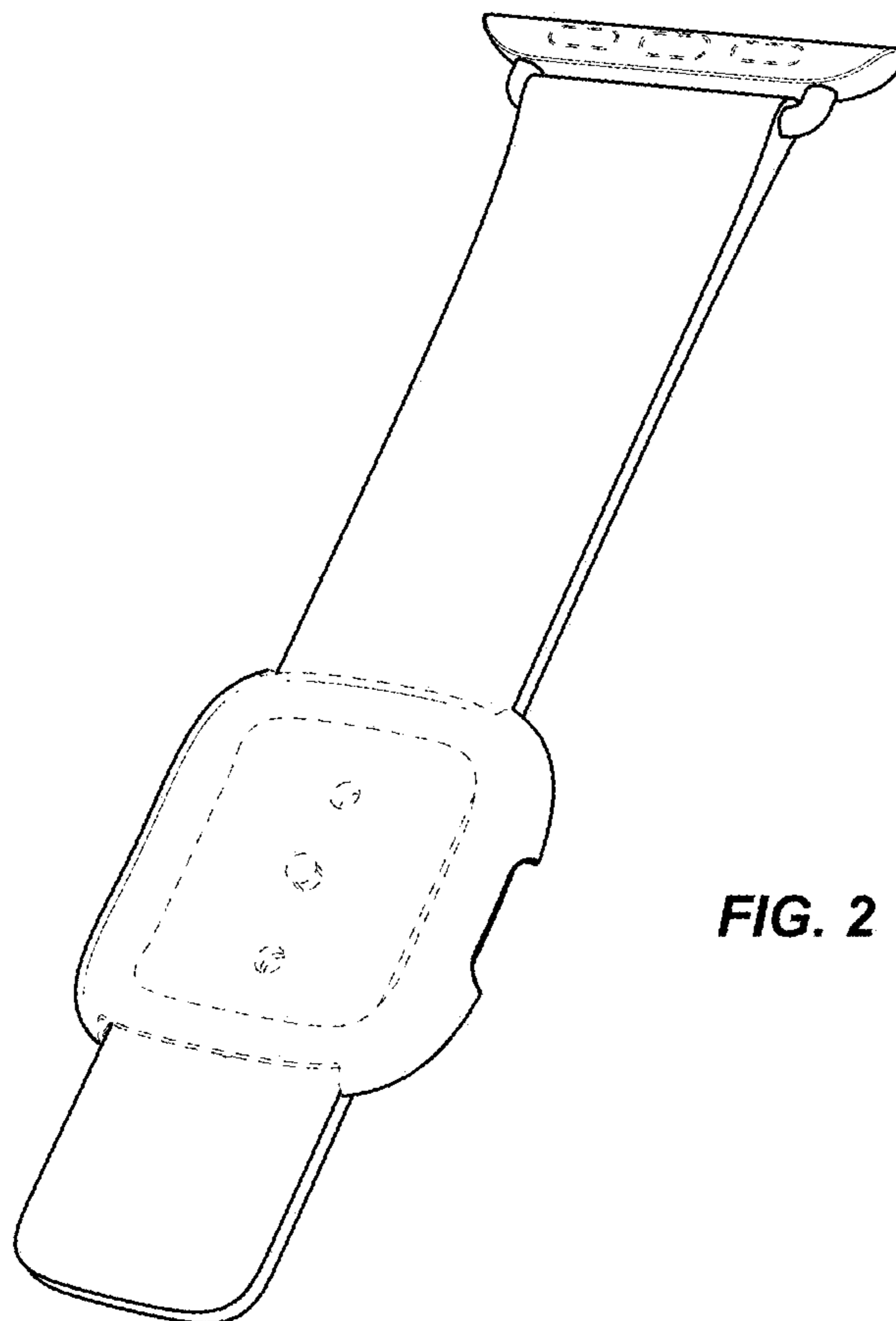
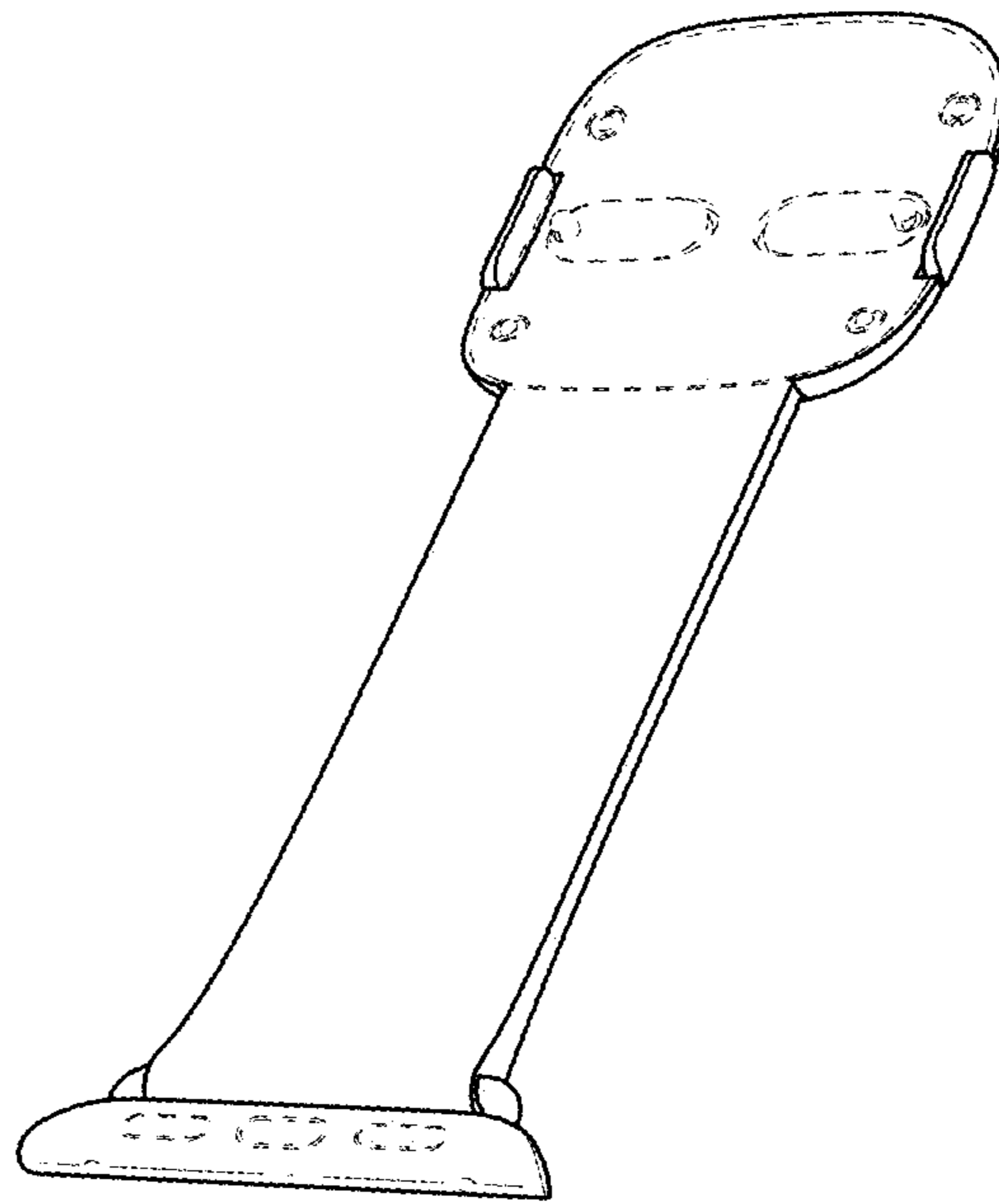
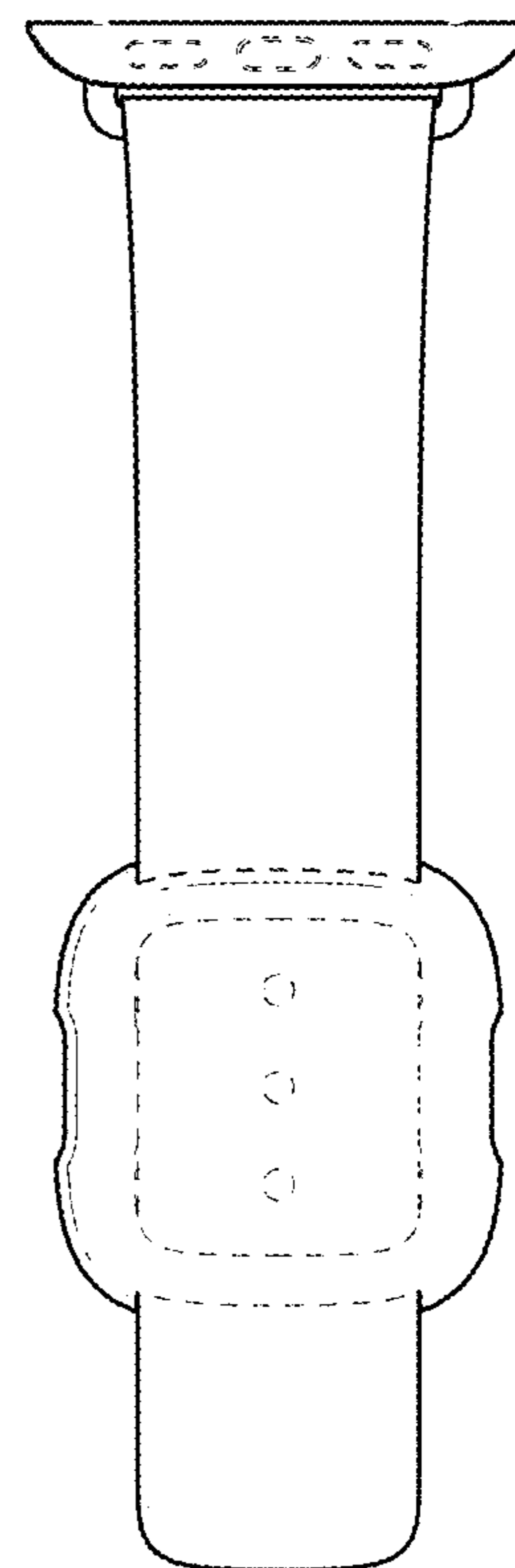
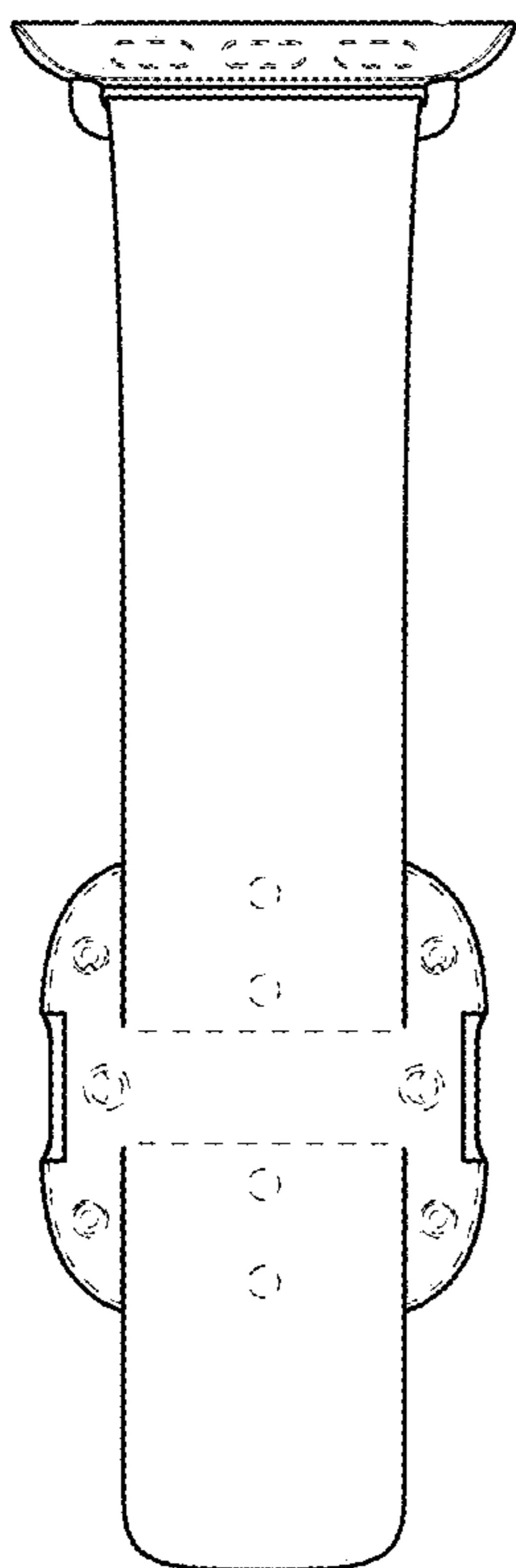
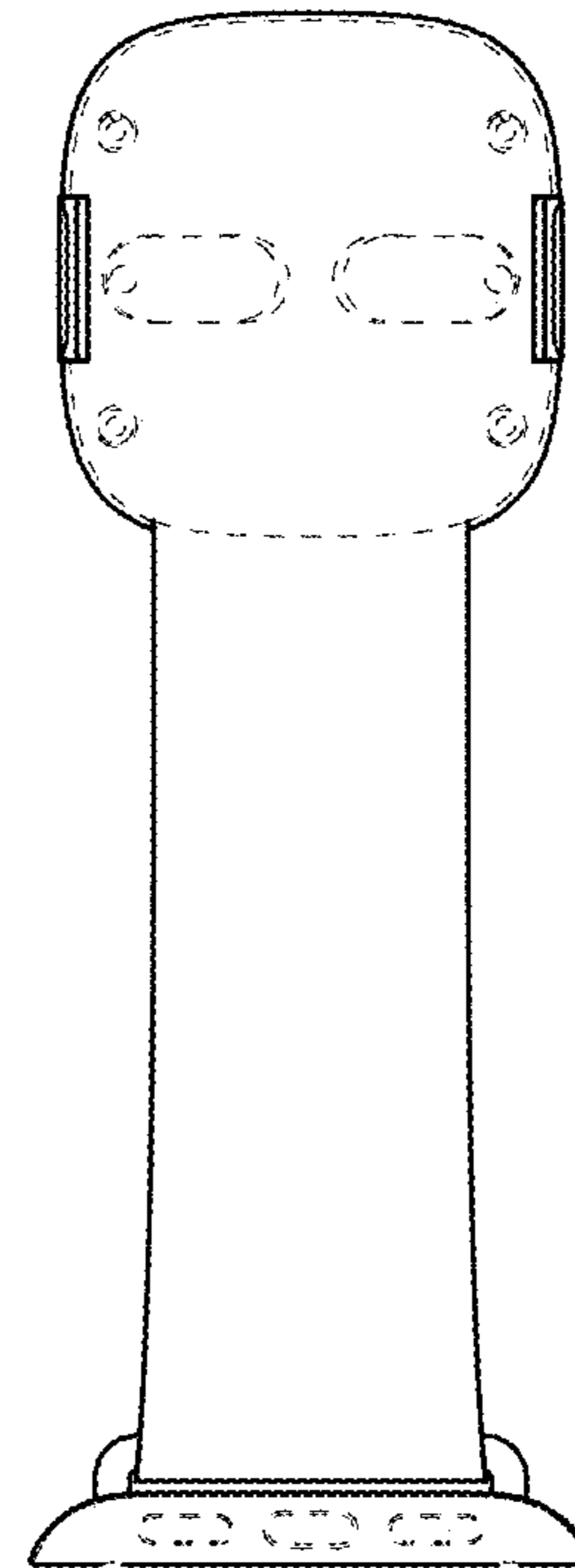
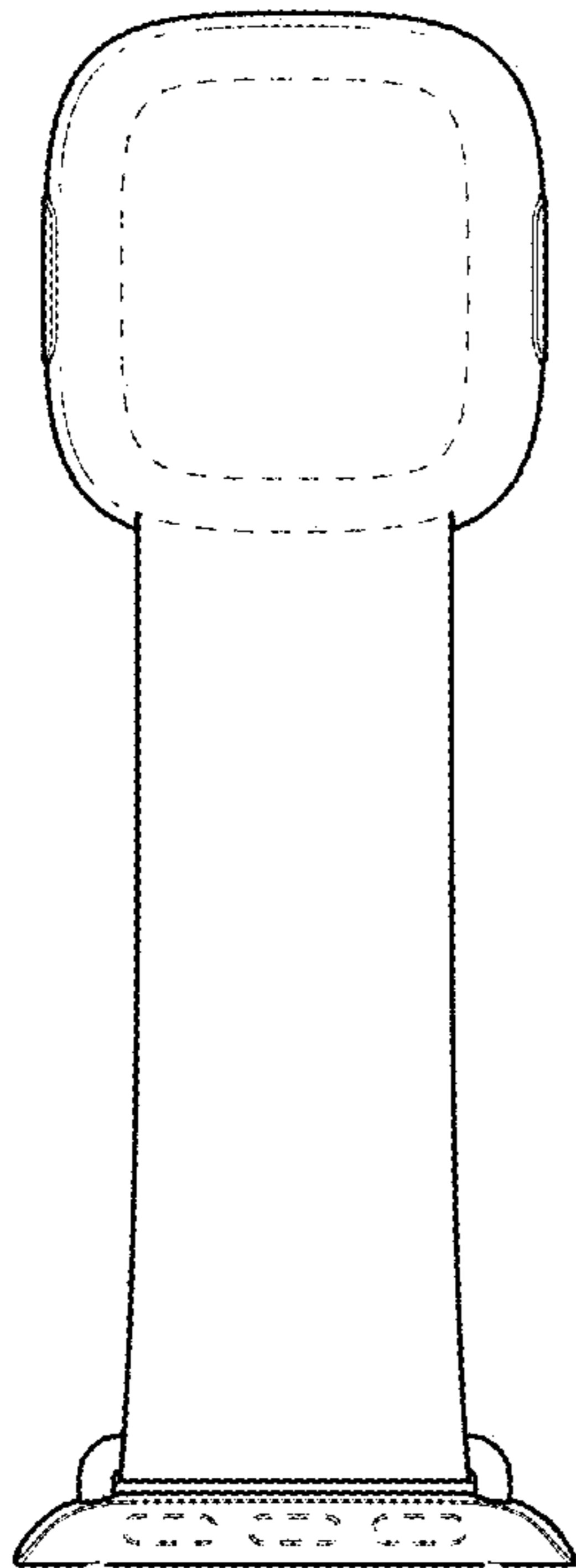
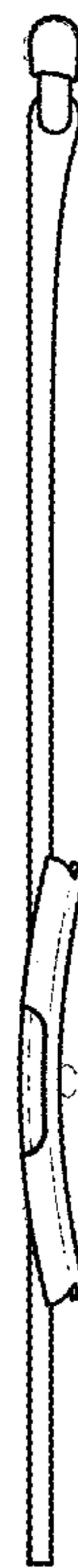
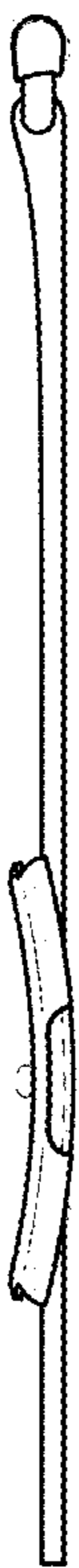
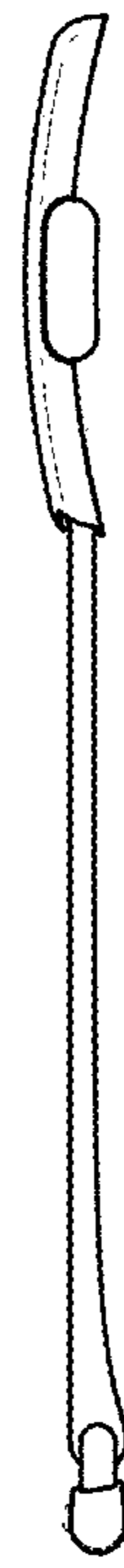
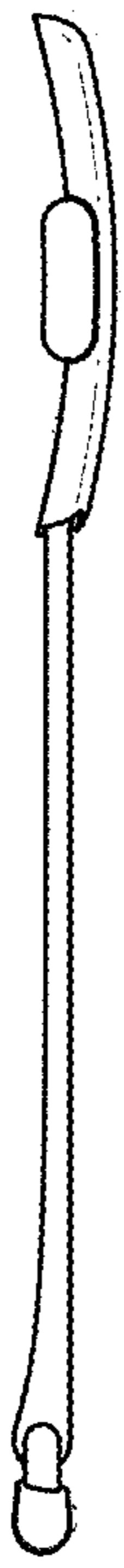


FIG. 2



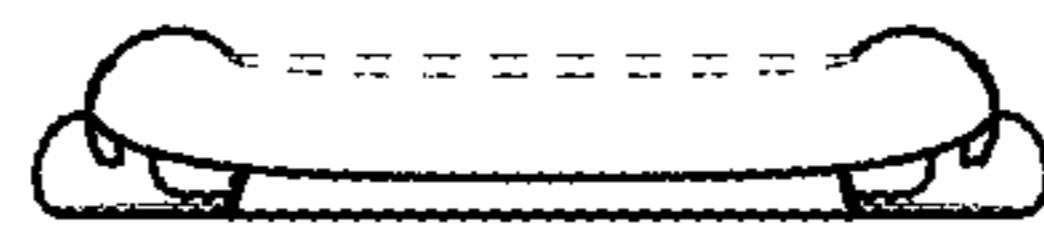
**FIG. 3**

**FIG. 4**

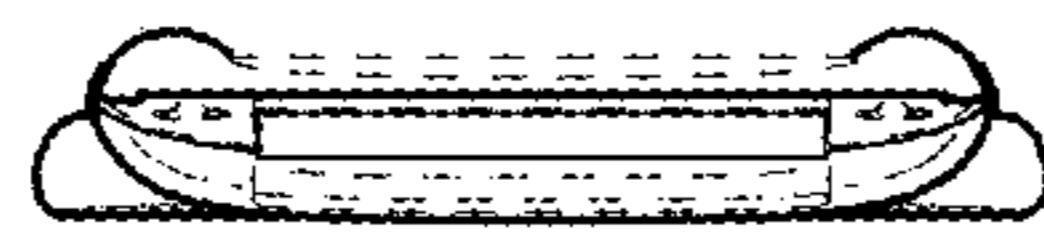


**FIG. 5**

**FIG. 6**

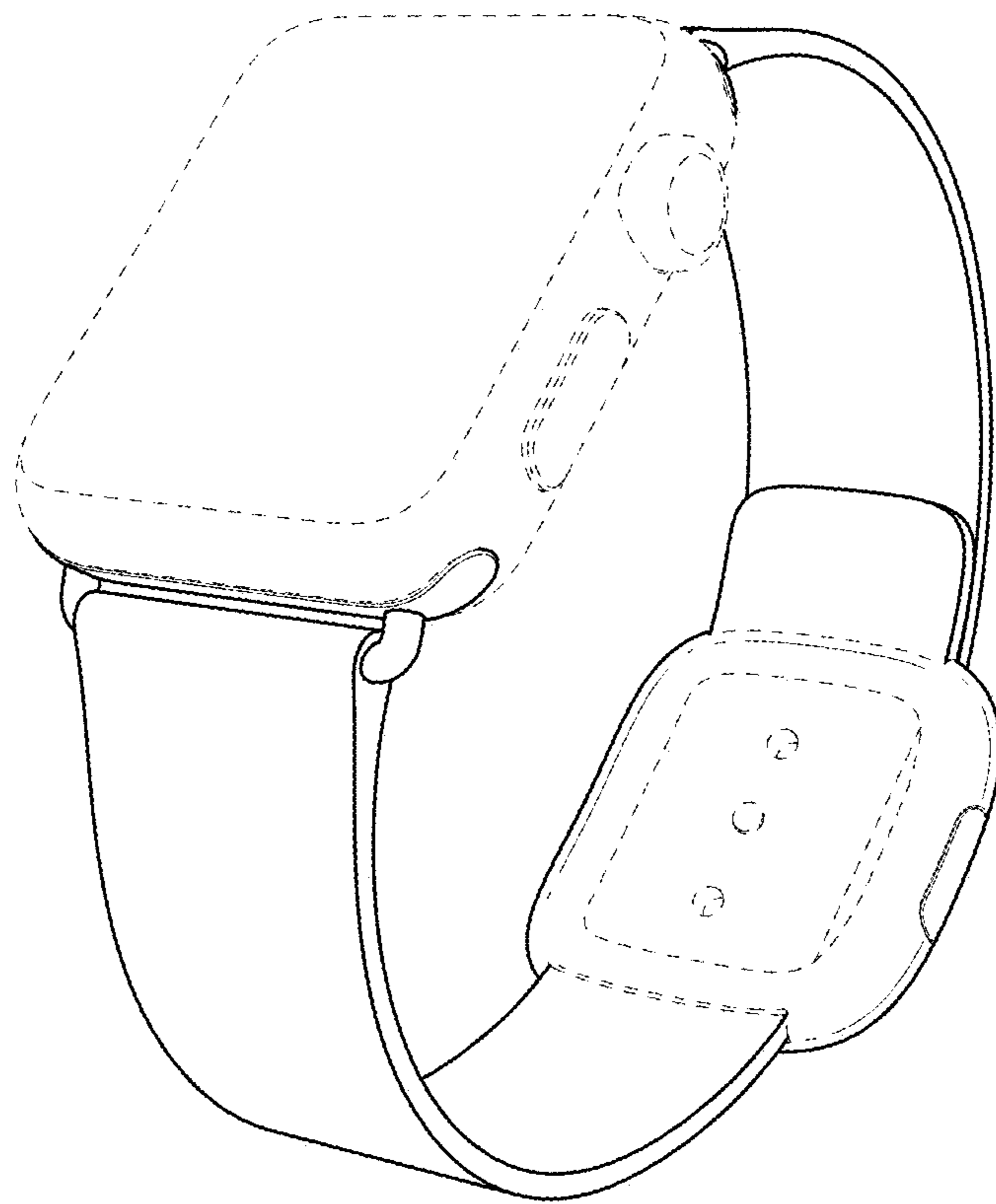


**FIG. 7**



**FIG. 8**





**FIG. 9**