



US00D912220S

(12) **United States Design Patent**
Bayless et al.

(10) **Patent No.:** **US D912,220 S**
(45) **Date of Patent:** **** Mar. 2, 2021**

(54) **DRAIN PIPE**

(71) Applicants: **Benjamin Bayless**, Chattanooga, TN (US); **James Andrew Burran**, Chattanooga, TN (US); **Michael Cox**, Chattanooga, TN (US)

(72) Inventors: **Benjamin Bayless**, Chattanooga, TN (US); **James Andrew Burran**, Chattanooga, TN (US); **Michael Cox**, Chattanooga, TN (US)

(73) Assignee: **AFS Newco, LLC**, Virginia Beach, VA (US)

(**) Term: **15 Years**

(21) Appl. No.: **29/704,158**

(22) Filed: **Sep. 3, 2019**

(51) **LOC (13) Cl.** **23-01**

(52) **U.S. Cl.**
USPC **D23/266; D23/267**

(58) **Field of Classification Search**
USPC **D23/267, 259-262, 265-266; 210/163-164; 52/169.5; 4/613, 679,**
(Continued)

(56) **References Cited**

U.S. PATENT DOCUMENTS

D10,632 S * 4/1878 Starr D23/266
D16,877 S * 8/1886 Briggs D23/266
(Continued)

Primary Examiner — Amy C Wierenga

(74) *Attorney, Agent, or Firm* — Jeremy A. Smith; Lanier Ford Shaver & Payne, PC

(57) **CLAIM**

The ornamental design for a drain pipe, as shown and described.

DESCRIPTION

FIG. 1 shows a right perspective view of a first embodiment of the drain pipe of the present application;

FIG. 2 shows a left perspective view of the drain pipe of the present application;

FIG. 3 shows an alternate view of the view of the drain pipe shown in FIG. 1;

FIG. 4 shows an alternate view of the view of the drain pipe shown in FIG. 2;

FIG. 5 shows an end view of the drain pipe shown in FIGS. 1-4. The opposing end view is identical;

FIG. 6 shows a side view of the drain pipe shown in FIGS. 1-5;

FIG. 7 shows an alternate side view of the drain pipe shown in FIGS. 1-6;

FIG. 8 shows a top view of the drain pipe shown in FIGS. 1-7;

FIG. 9 shows a bottom view of the drain pipe shown in FIGS. 1-8;

FIG. 10 shows a close-up view of the drain pipe in FIGS. 1-9;

FIG. 11 shows an alternate close-up view of the drain pipe in FIGS. 1-10;

FIG. 12 shows a close-up view of the drain pipe in FIGS. 1-11; and

FIG. 13 shows an alternate close-up view of the drain pipe in FIGS. 1-12.

FIG. 14 shows a right perspective view of a second embodiment of drain pipe of the present application;

FIG. 15 shows a left perspective view of the second embodiment of the drain pipe of the present application;

FIG. 16 shows an alternate view of the second embodiment of the drain pipe shown in FIG. 14;

FIG. 17 shows an alternate view of the second embodiment of the drain pipe shown in FIG. 15;

FIG. 18 shows an end view of the drain pipe shown in FIGS. 14-17. The opposing end view is identical;

FIG. 19 shows a side view of the drain pipe shown in FIGS. 14-18;

FIG. 20 shows an alternate side view of the drain pipe shown in FIGS. 14-19;

FIG. 21 shows a top view of the drain pipe shown in FIGS. 14-20;

FIG. 22 shows a bottom view of the drain pipe shown in FIGS. 14-21;

(Continued)

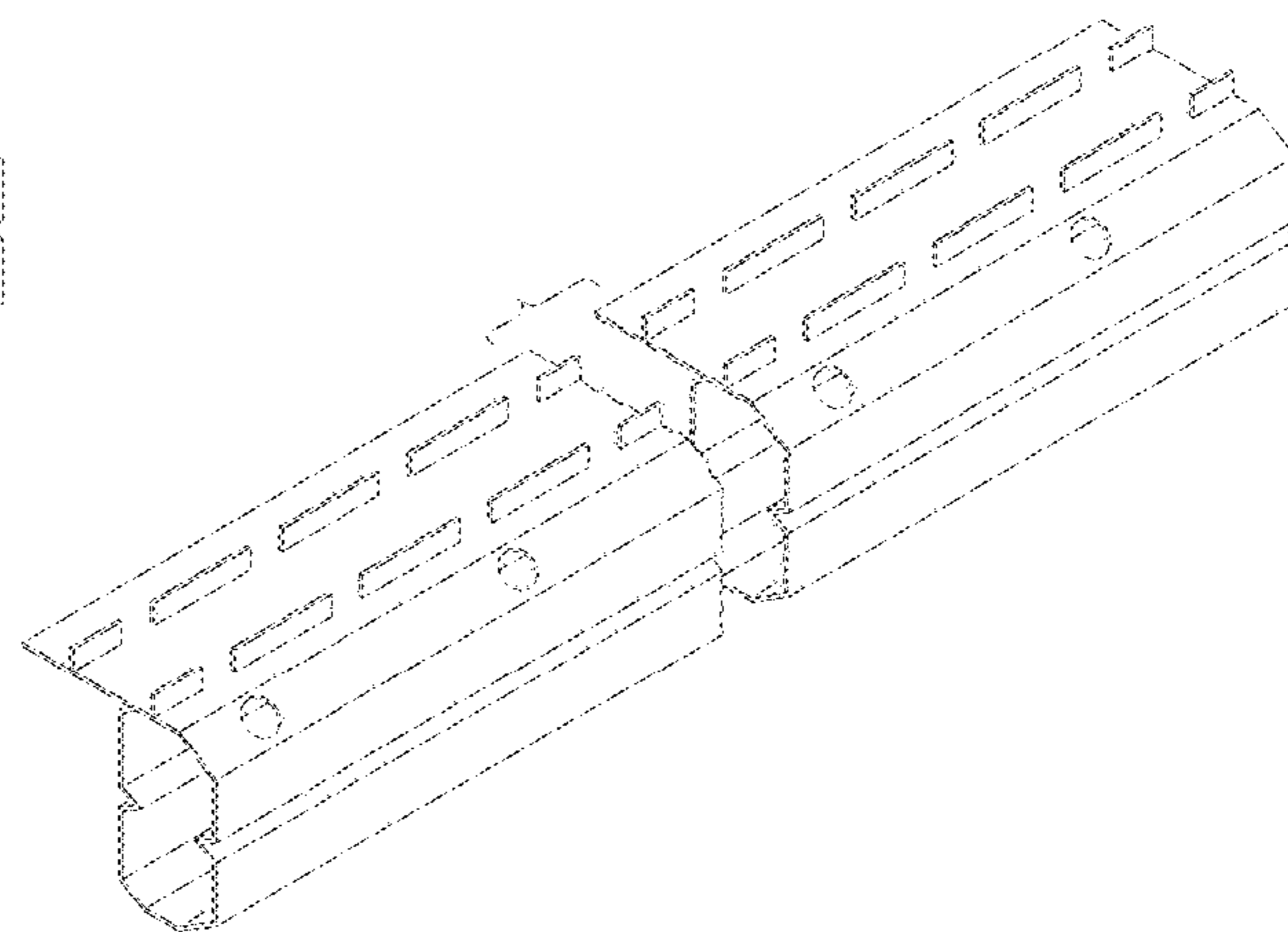
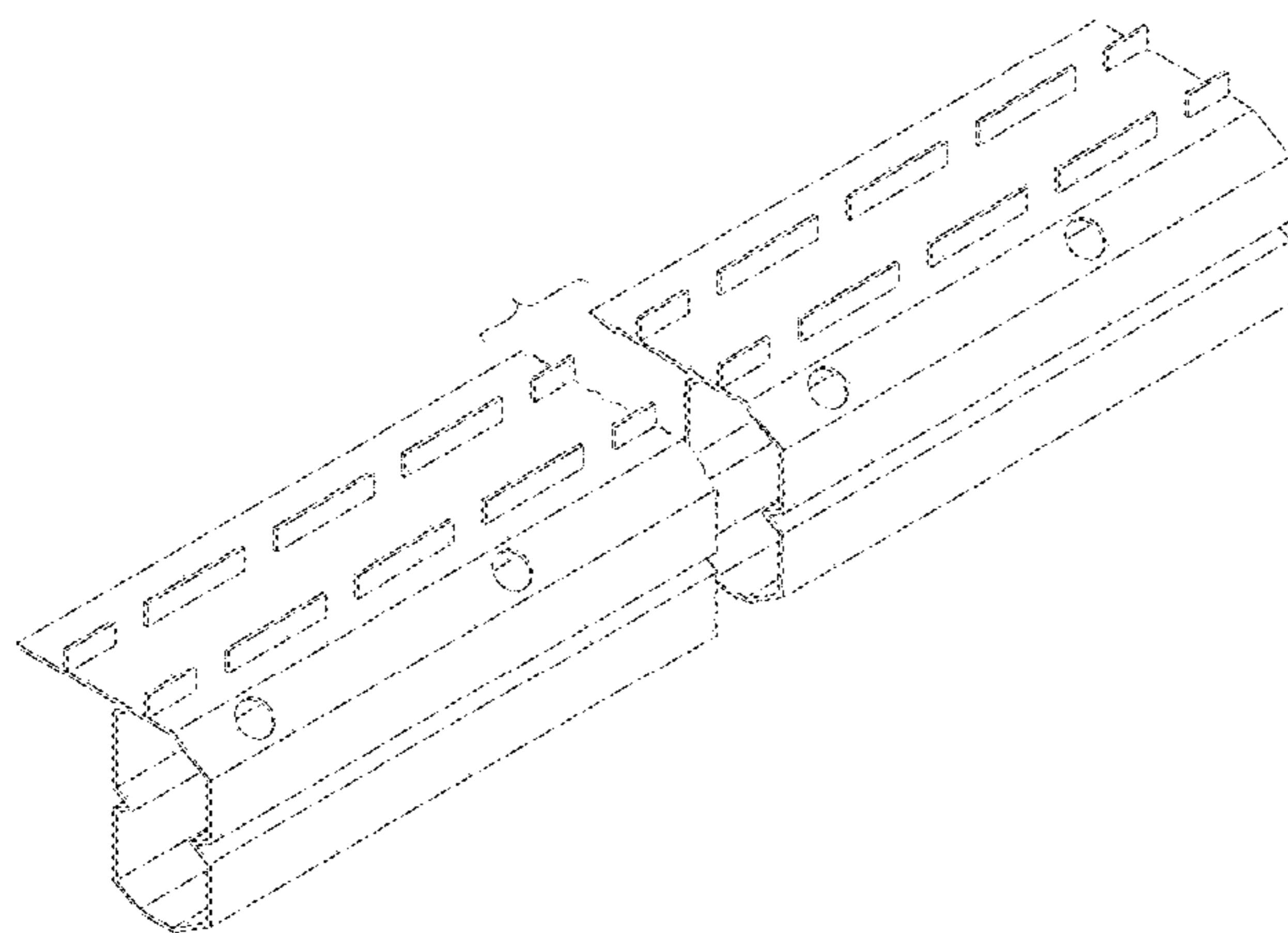

FIG. 23 shows a close-up view of the drain pipe in FIGS. 14-22;
 FIG. 24 shows an alternate close-up view of the drain pipe in FIGS. 14-23;
 FIG. 25 shows a close-up view of the drain pipe in FIGS. 14-24; and
 FIG. 26 shows an alternate close-up view of the drain pipe in FIGS. 14-25.
 FIG. 27 shows a right perspective view of a third embodiment of drain pipe of the present application;
 FIG. 28 shows a left perspective view of the third embodiment of the drain pipe of the present application;
 FIG. 29 shows an alternate view of the third embodiment of the drain pipe shown in FIG. 27;
 FIG. 30 shows an alternate view of the third embodiment of the drain pipe shown in FIG. 28;
 FIG. 31 shows an end view of the drain pipe shown in FIGS. 27-28. The opposing end view is identical;
 FIG. 32 shows a side view of the drain pipe shown in FIGS. 27-31;
 FIG. 33 shows an alternate side view of the drain pipe shown in FIGS. 27-31;
 FIG. 34 shows a top view of the drain pipe shown in FIGS. 27-33;
 FIG. 35 shows a bottom view of the drain pipe shown in FIGS. 27-34;
 FIG. 36 shows a close-up view of the drain pipe in FIGS. 27-35;
 FIG. 37 shows an alternate close-up view of the drain pipe in FIGS. 27-36;
 FIG. 38 shows a close-up view of the drain pipe in FIGS. 27-37; and,
 FIG. 39 shows an alternate close-up view of the drain pipe in FIGS. 27-38.
 The broken lines shown in FIGS. 15-16, 20, 22-23, and 26 illustrate portions of the drain pipe that form no part of the

claim. The pipe is shown with a symbolic break to its length in FIGS. 10-13, 23-26, and 36-39. The appearance of any portion of the drain pipe between the break lines forms no part of the claim.

1 Claim, 21 Drawing Sheets

(58) **Field of Classification Search**

USPC 4/684, 689; 285/125.1, 126.1, 129.2,
 285/132.1, 360-361, 376, 396, 401-402;
 137/247.51
 CPC E02D 31/02; E03F 3/046; A47K 3/40
 See application file for complete search history.

(56) **References Cited**

U.S. PATENT DOCUMENTS

D488,545	S *	4/2004	Takamatu	D23/266
D498,825	S *	11/2004	Fu	D23/266
7,818,925	B2 *	10/2010	Benedict	E02D 27/02 52/169.5
8,109,045	B2 *	2/2012	Kliefoth	E02D 31/02 52/169.5
8,109,046	B2 *	2/2012	Nordhoff	E04B 1/7023 52/169.5
D840,001	S *	2/2019	Steylaerts	D23/261
D881,359	S *	4/2020	Hunter	D23/267
2005/0204653	A1 *	9/2005	Matthews	E02D 31/02 52/169.5
2006/0239781	A1 *	10/2006	Kliefoth	E02D 27/02 405/229
2008/0190045	A1 *	8/2008	Janesky	E02D 31/02 52/169.5
2012/0060433	A1 *	3/2012	Chandler	E02D 31/02 52/169.5
2020/0240100	A1 *	7/2020	Bayless	E02D 31/02

* cited by examiner

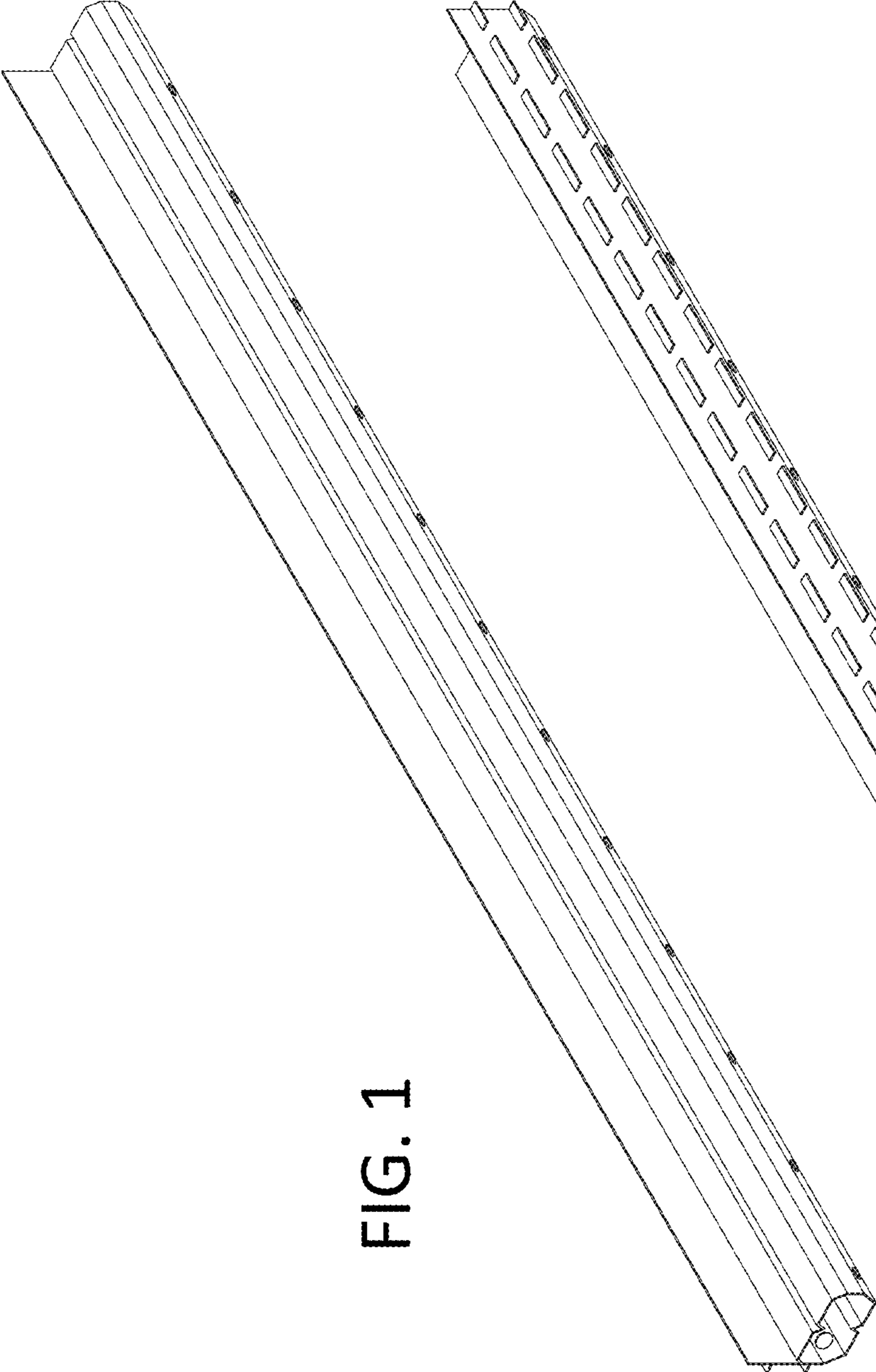

FIG. 1

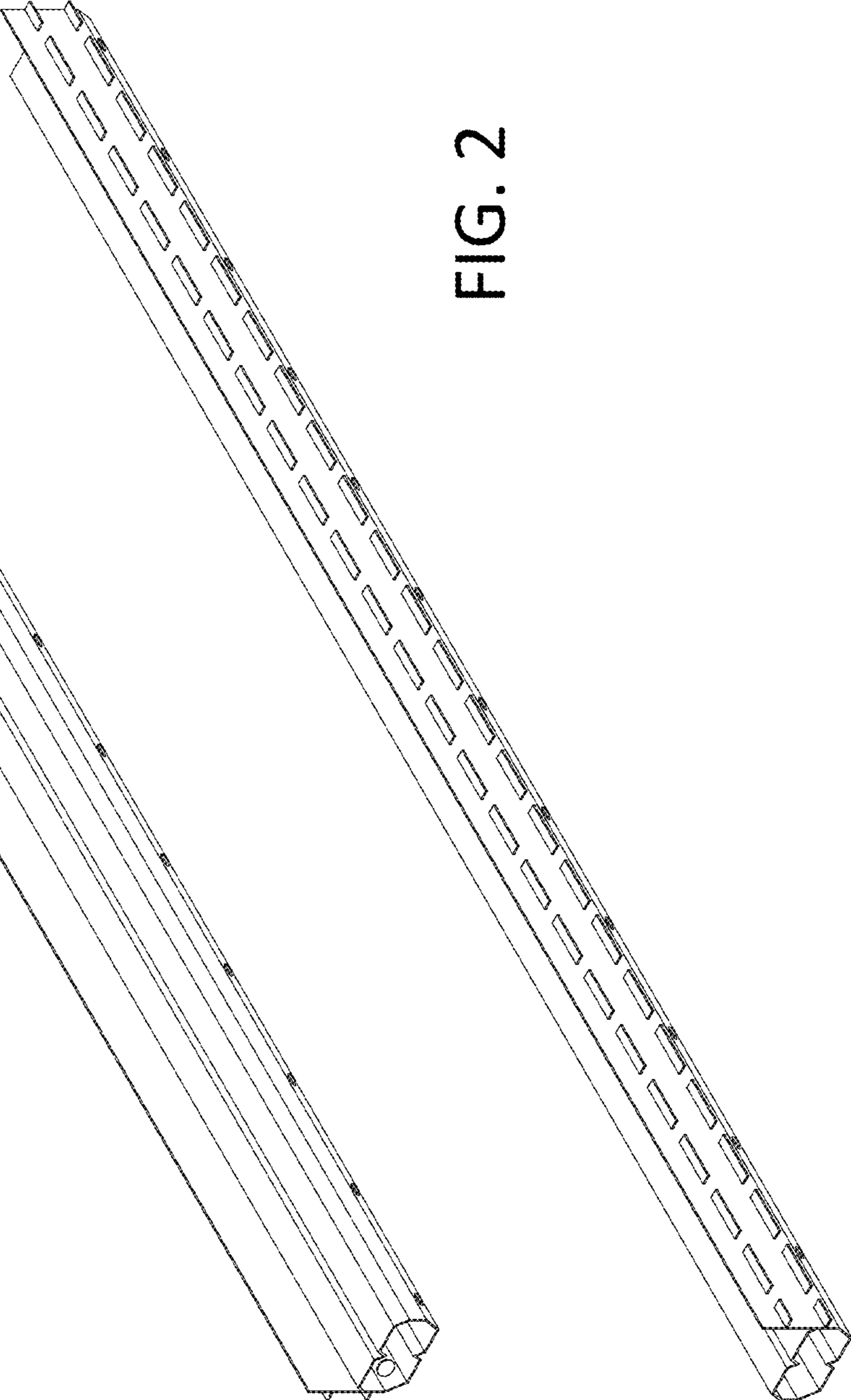

FIG. 2

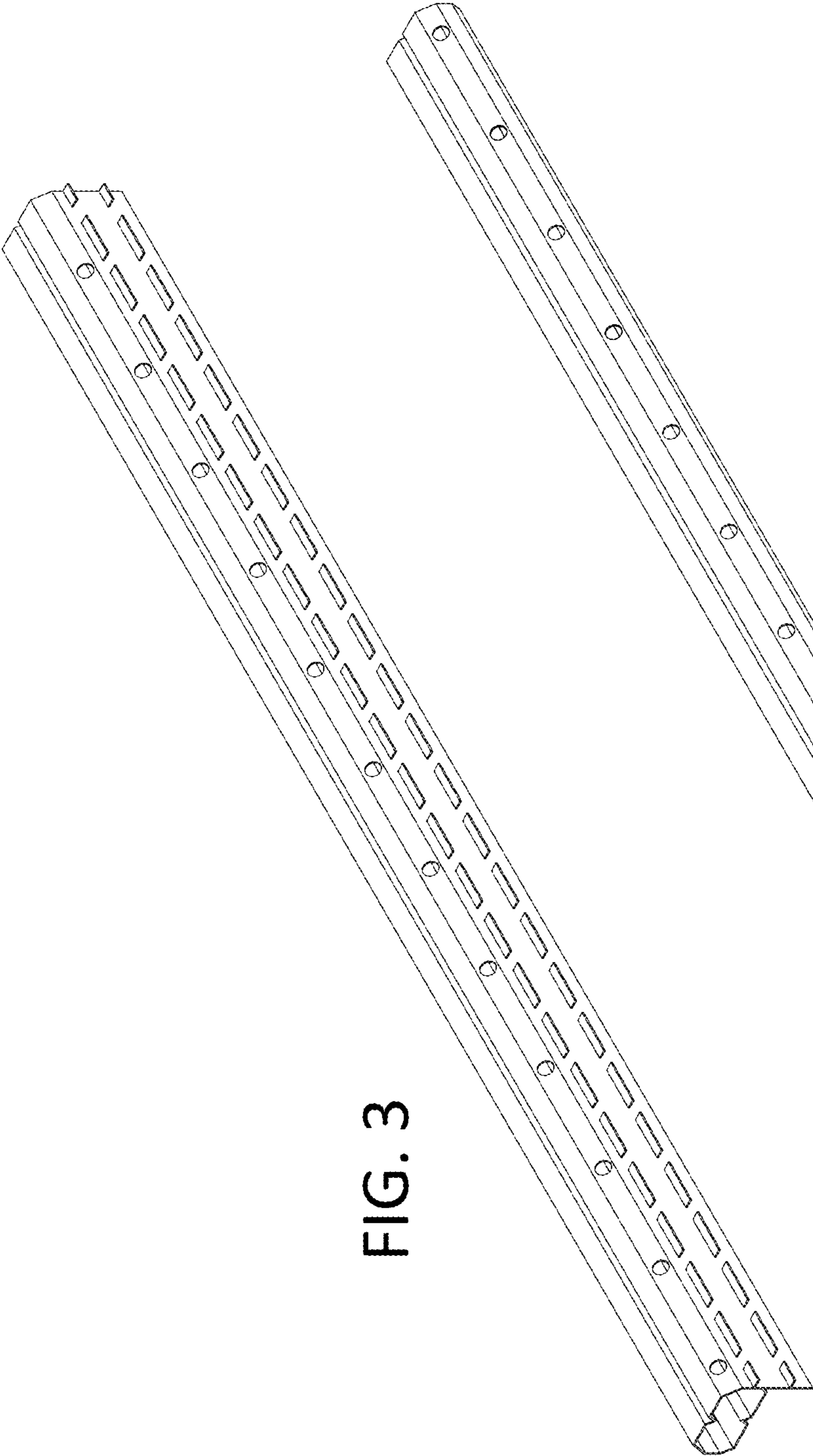

FIG. 3

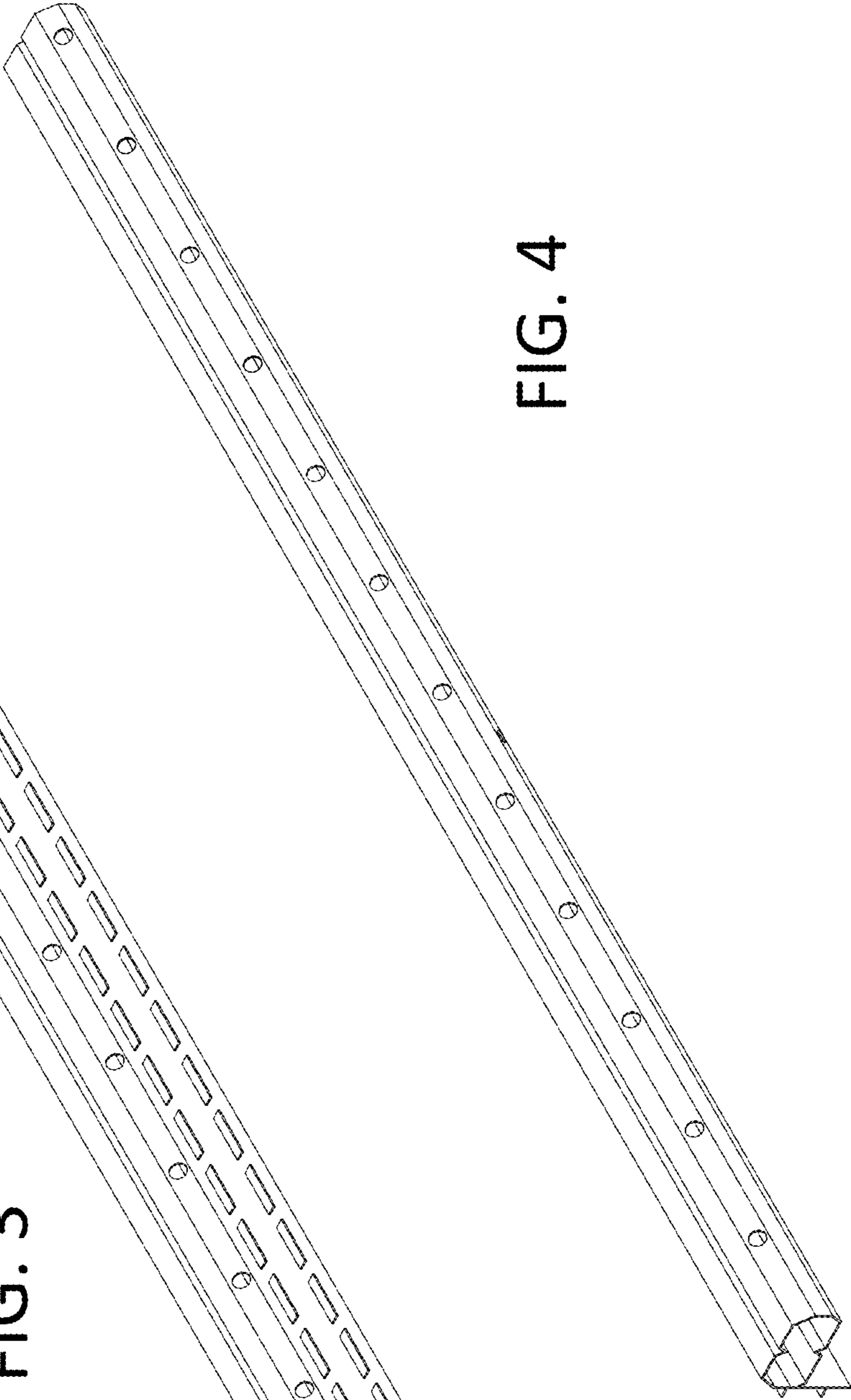

FIG. 4

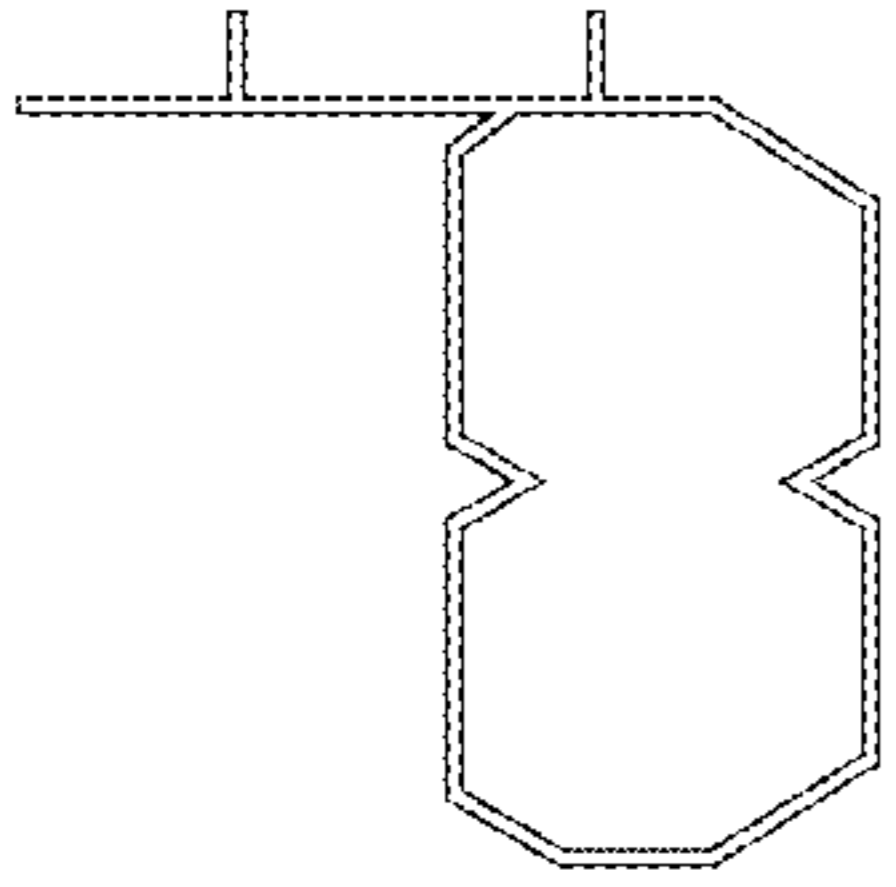

FIG. 5

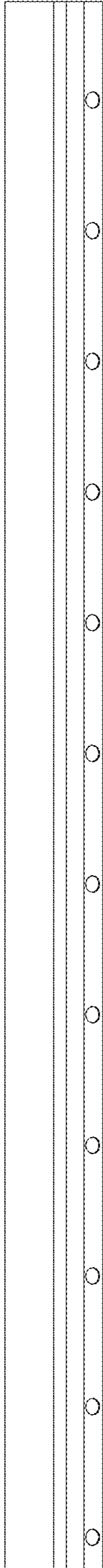

FIG. 6

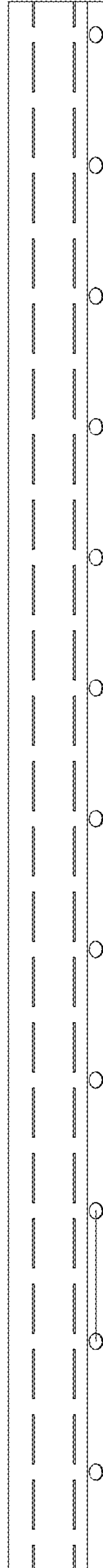

FIG. 7

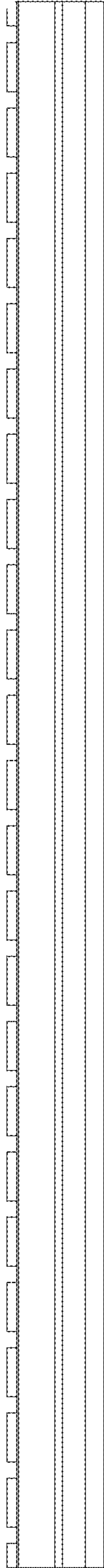

FIG. 8

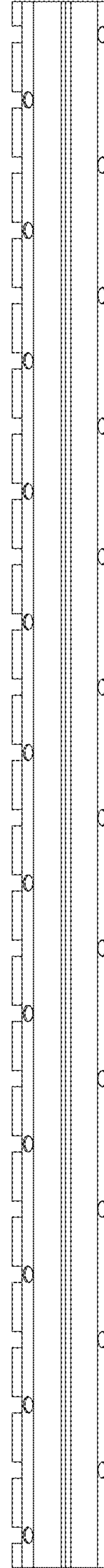

FIG. 9

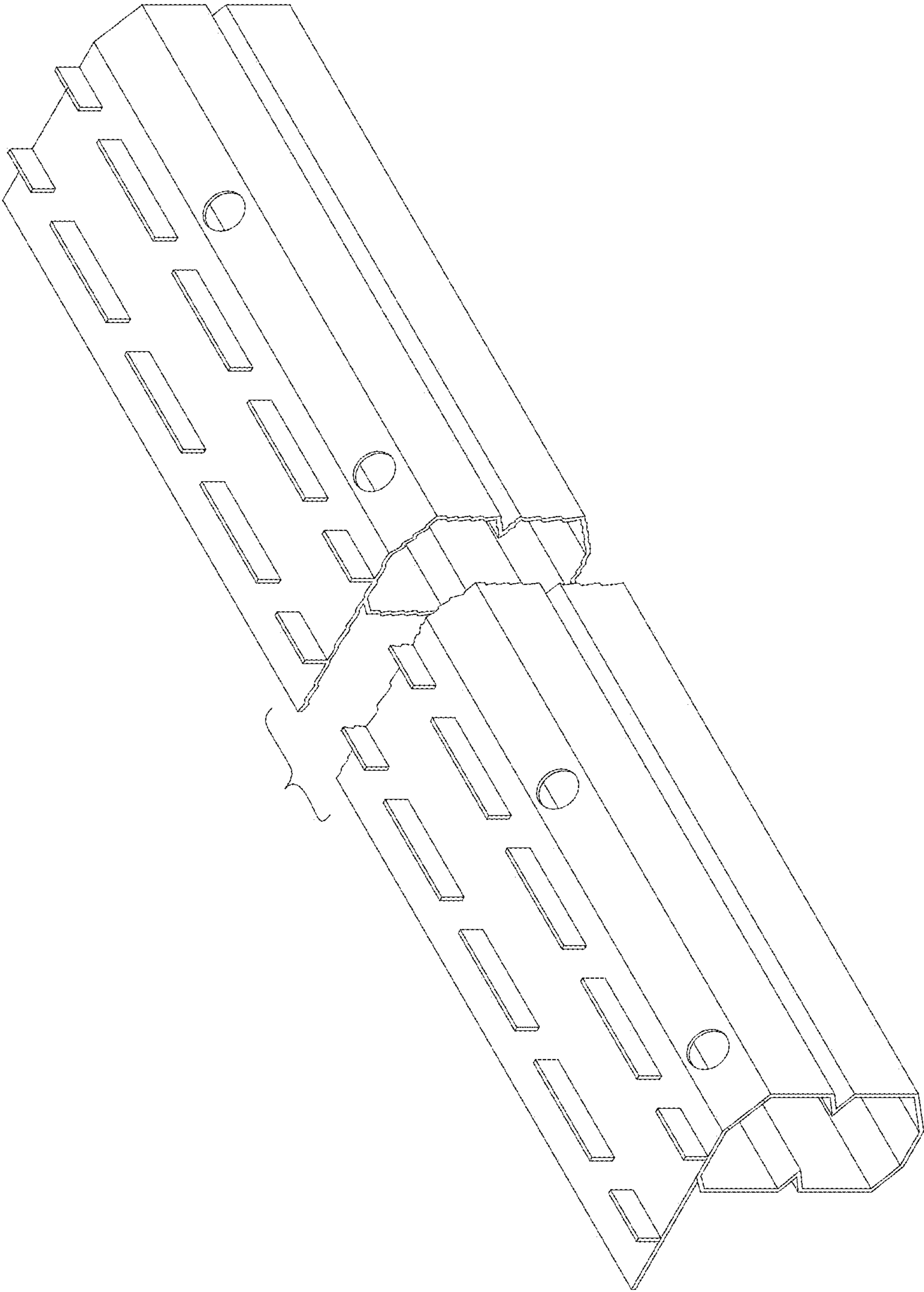

FIG. 10

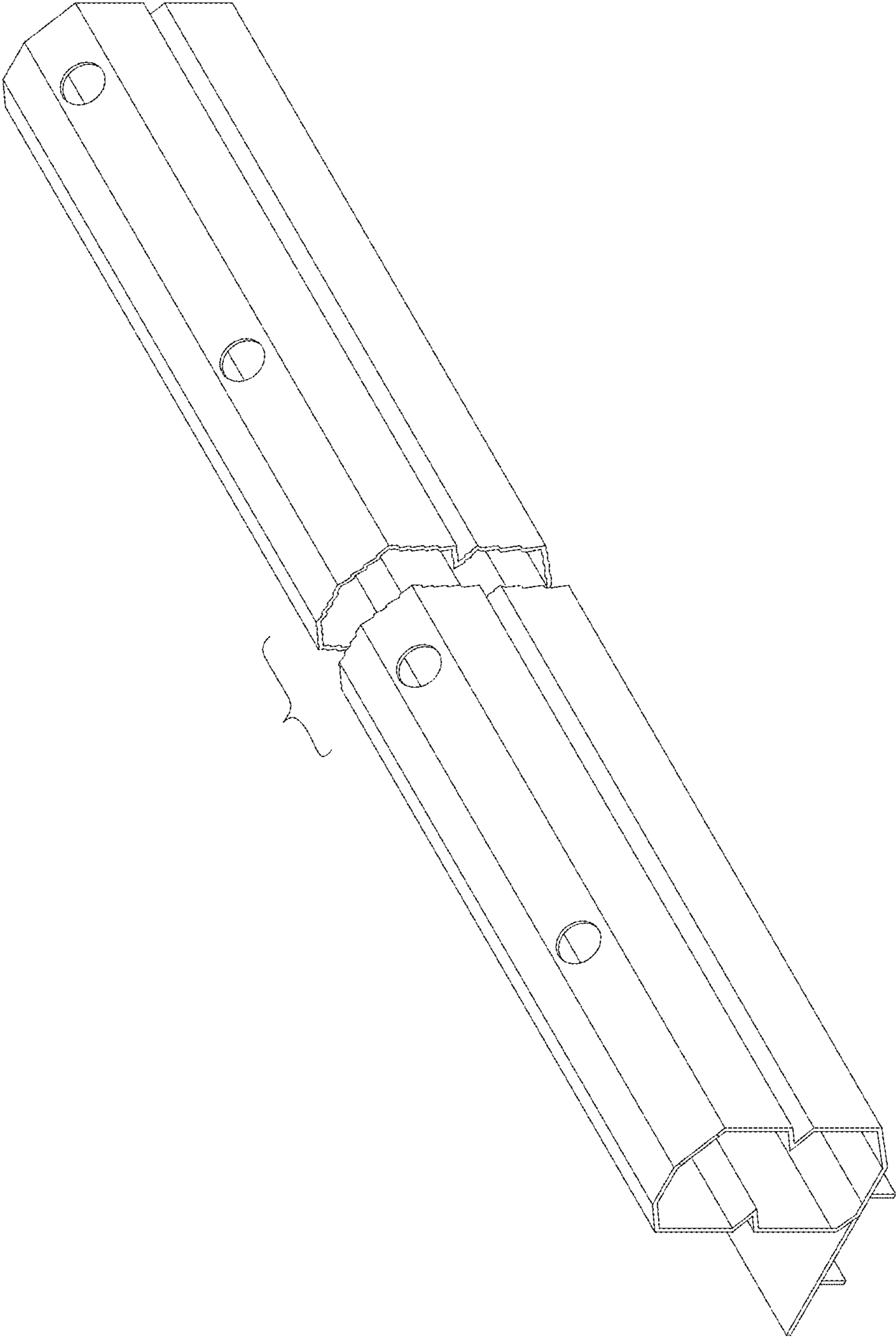

FIG. 11

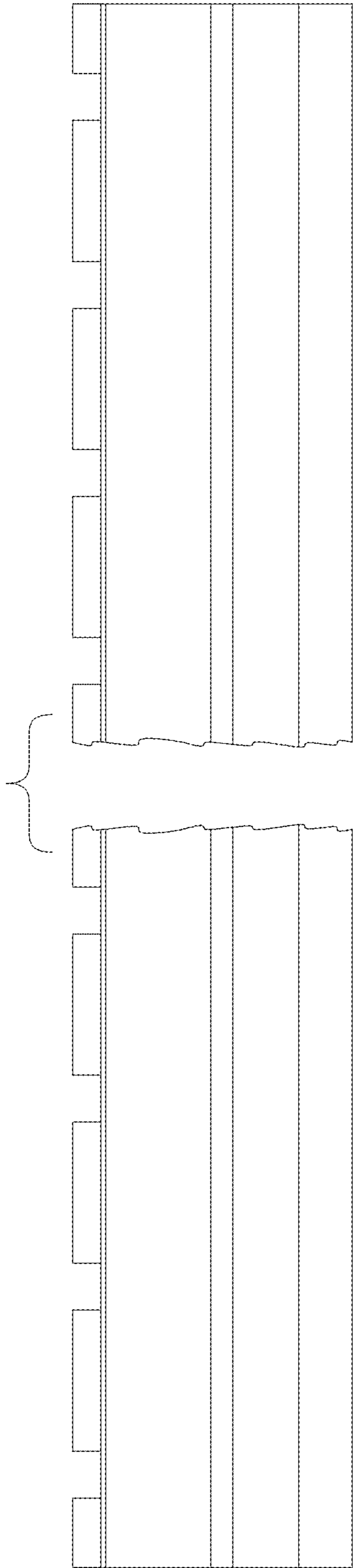

FIG. 12

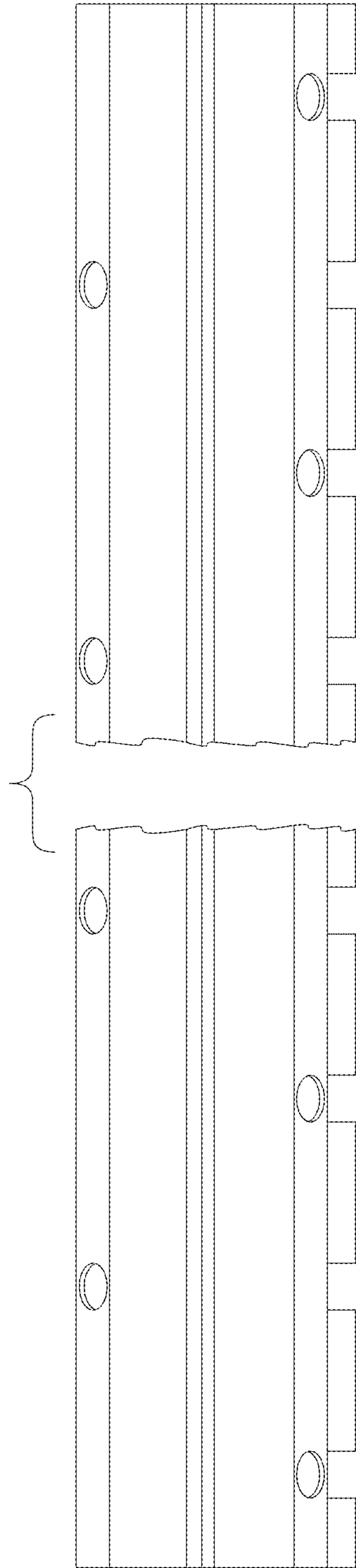

FIG. 13

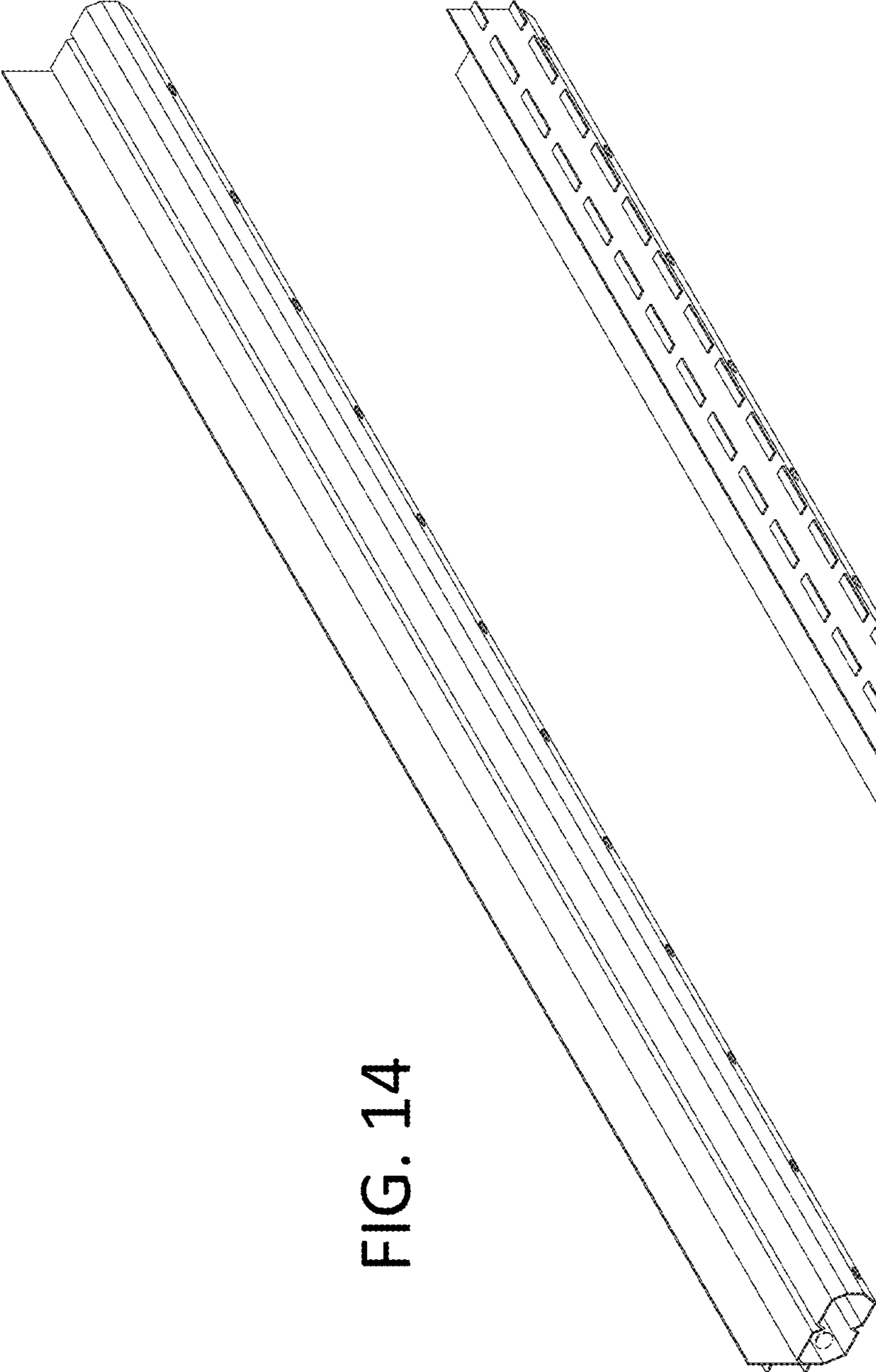

FIG. 14

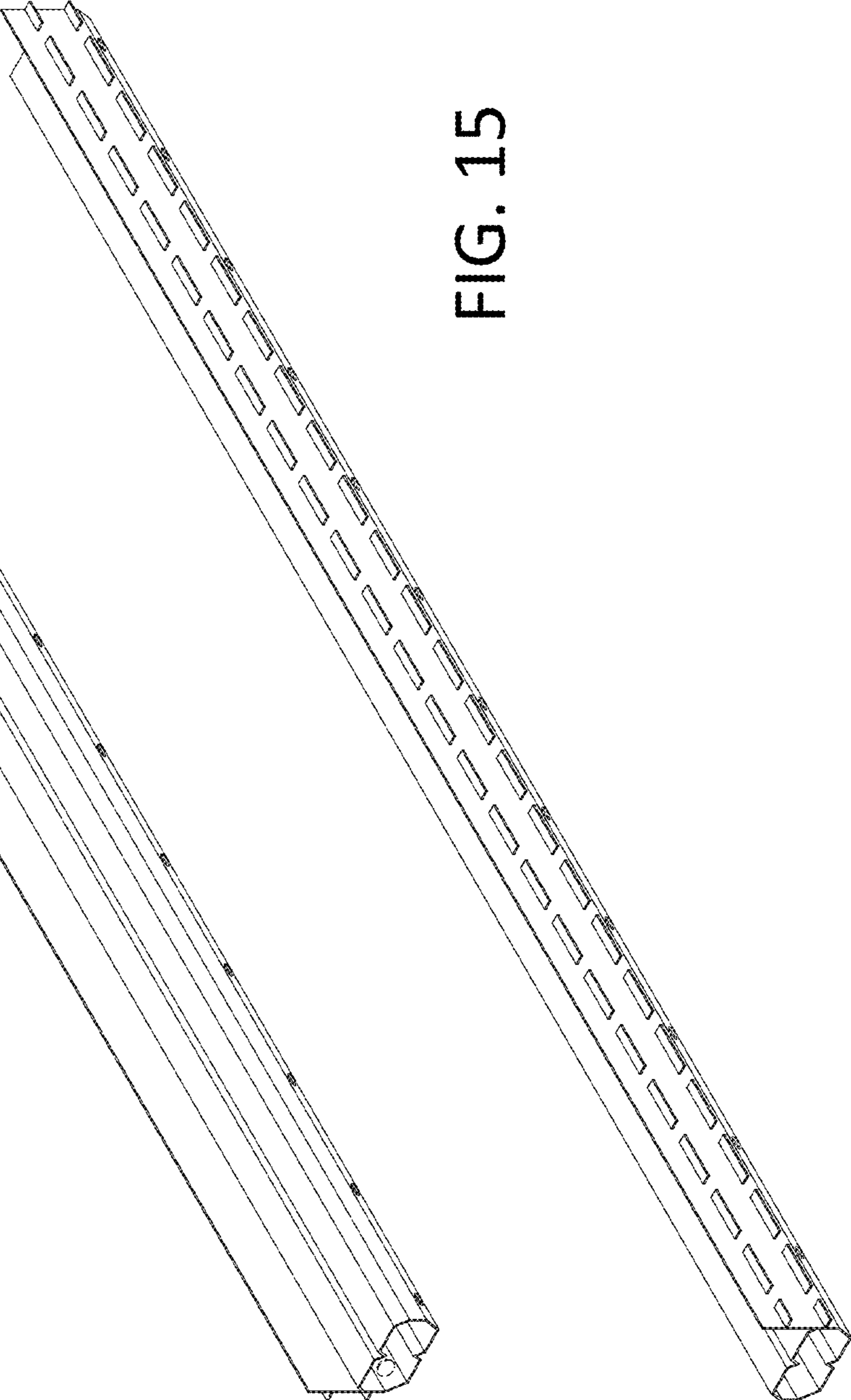

FIG. 15

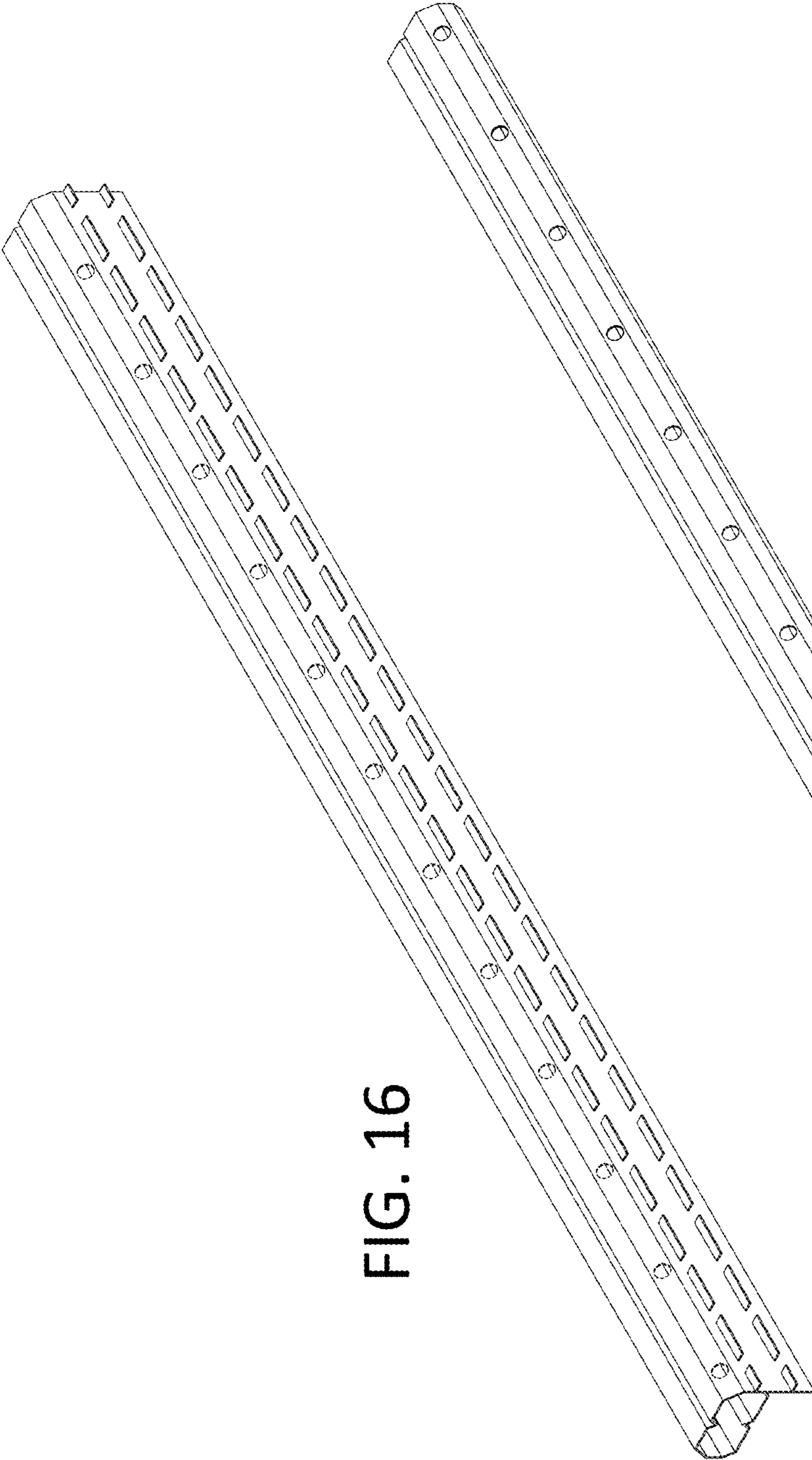

FIG. 16

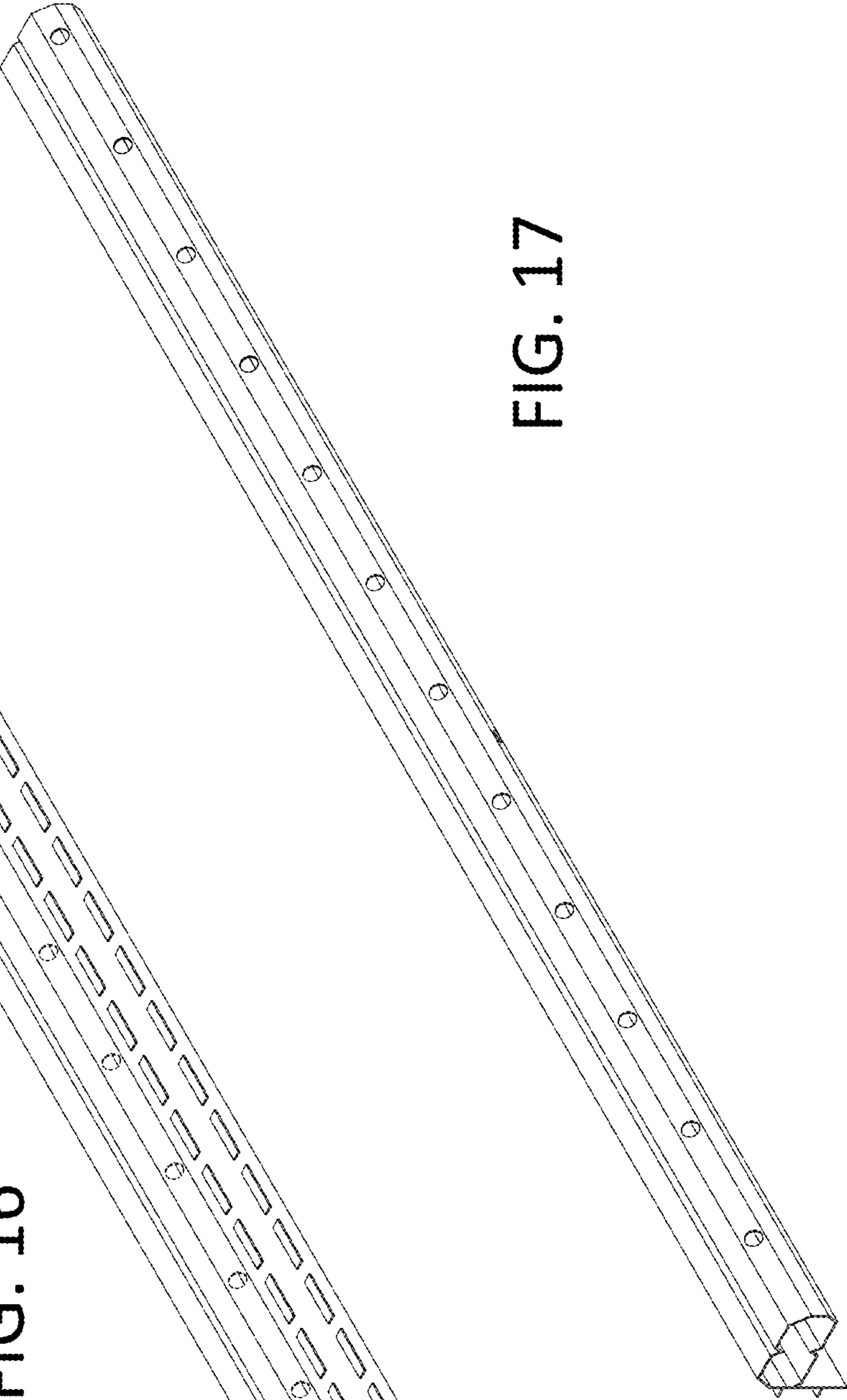

FIG. 17

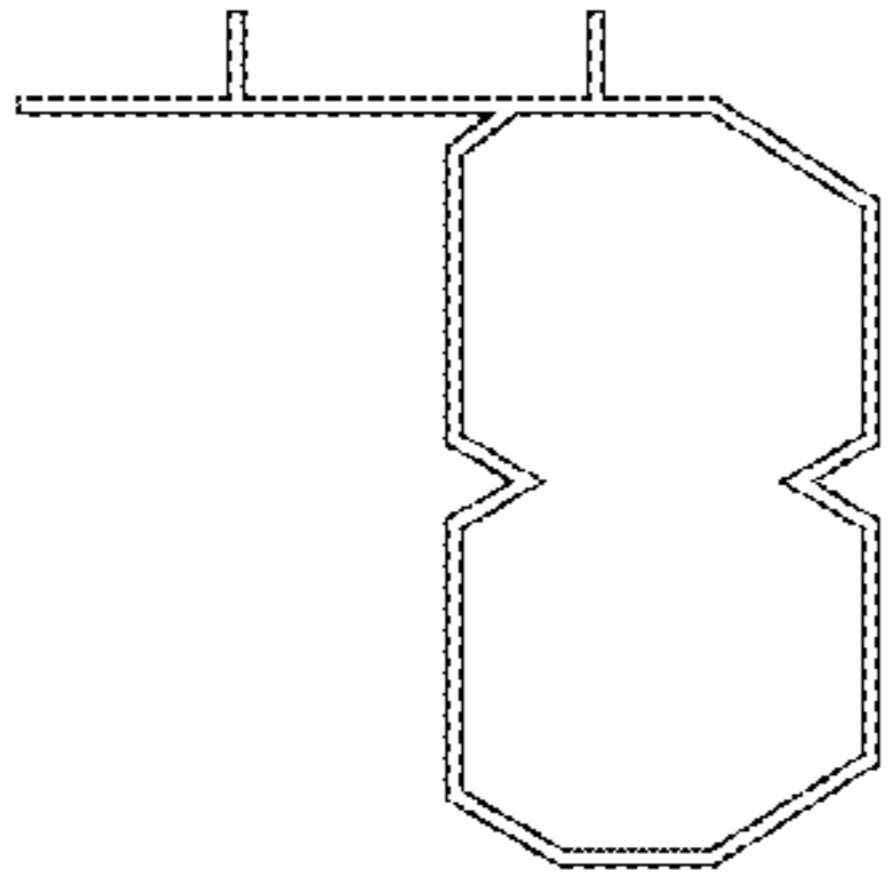

FIG. 18

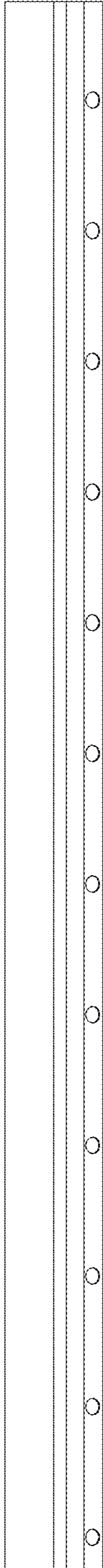

FIG. 19

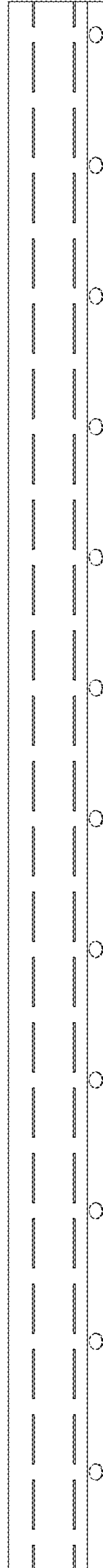

FIG. 20

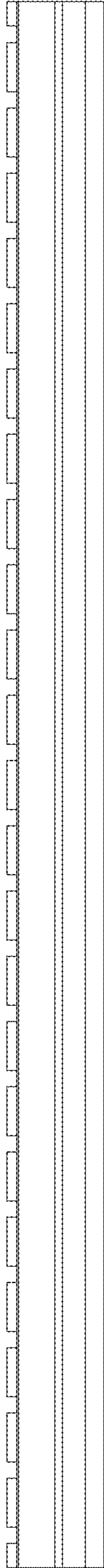

FIG. 21

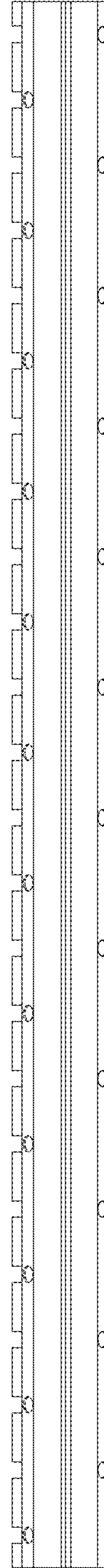

FIG. 22

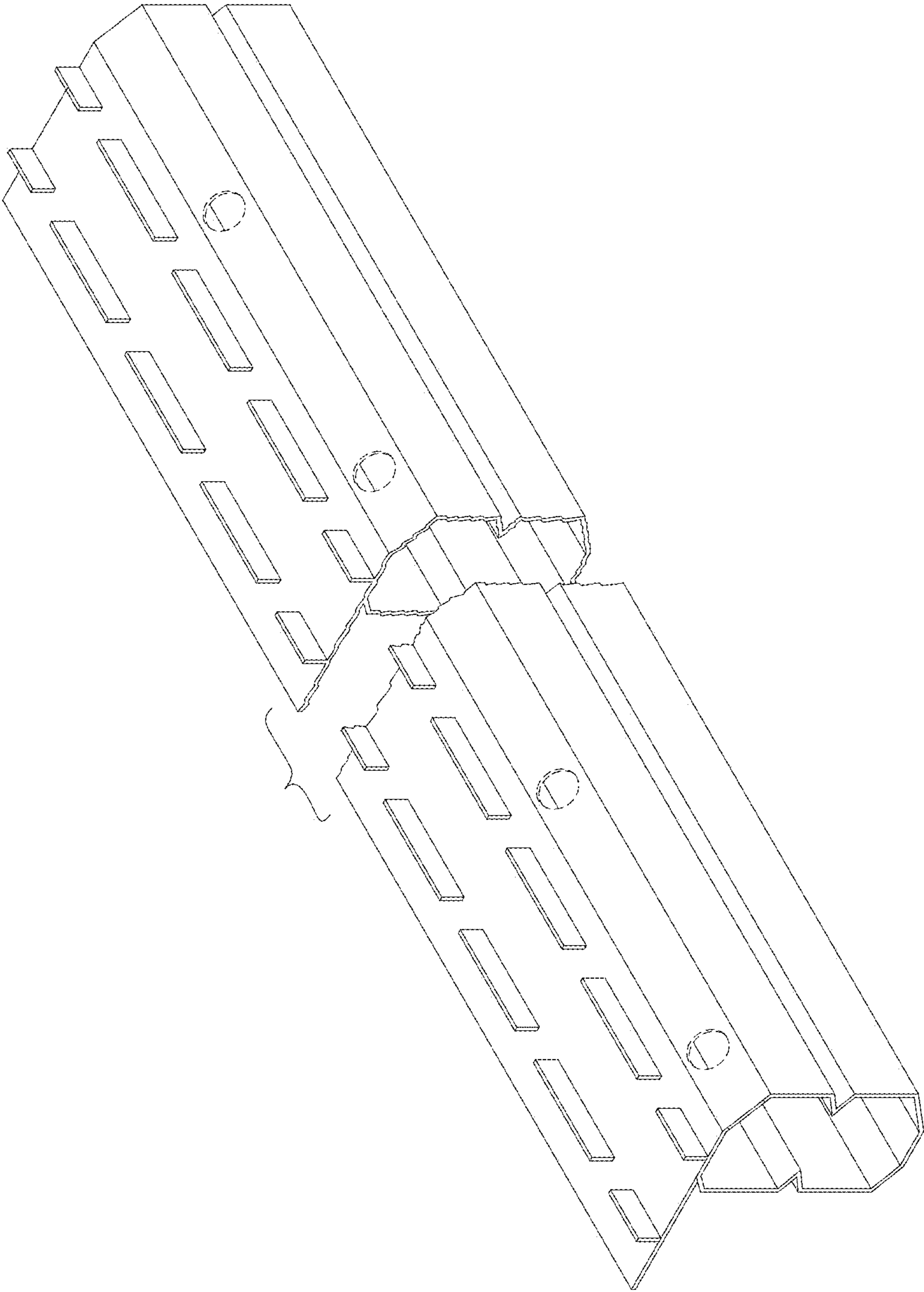

FIG. 23

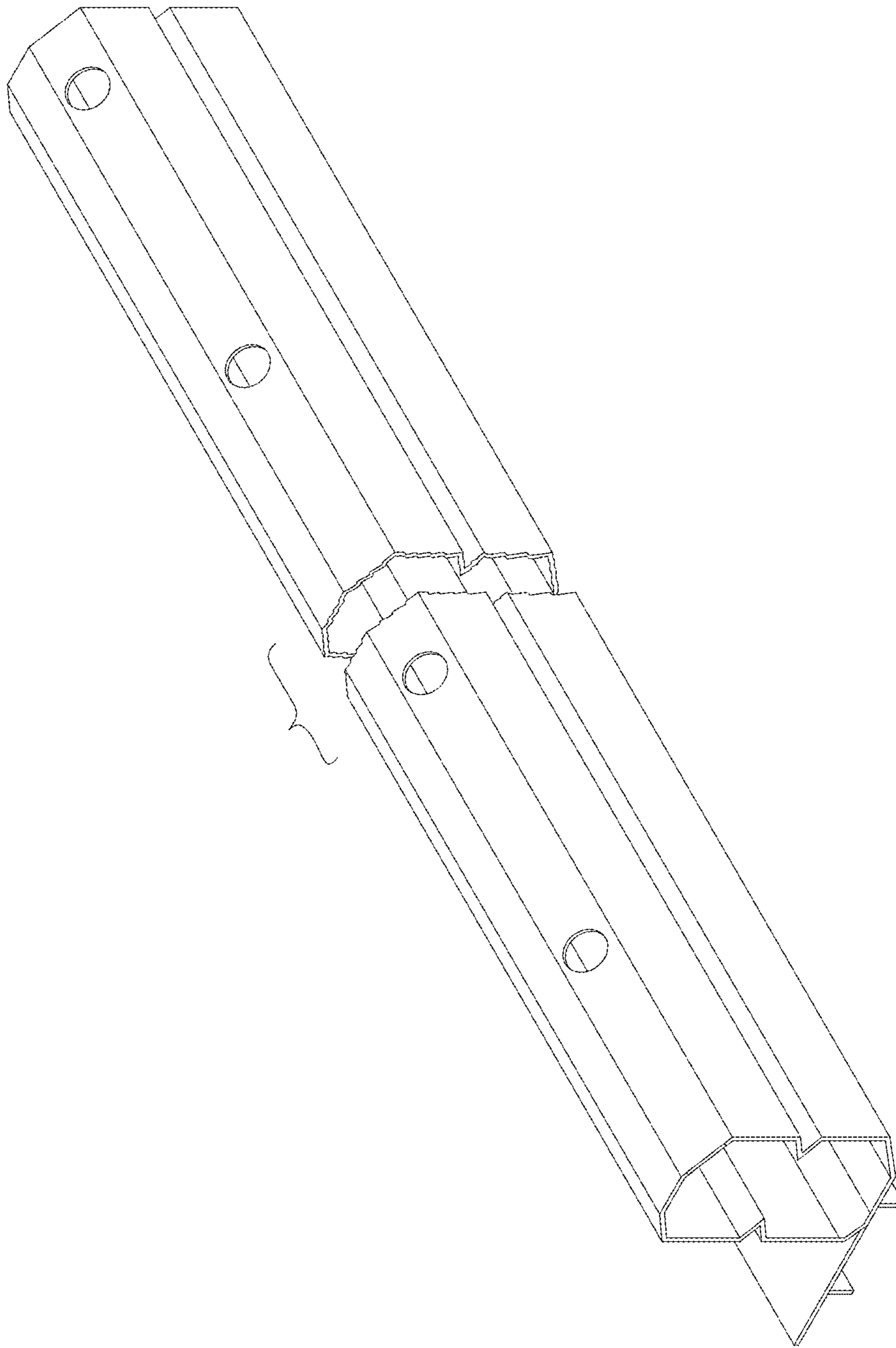

FIG. 24

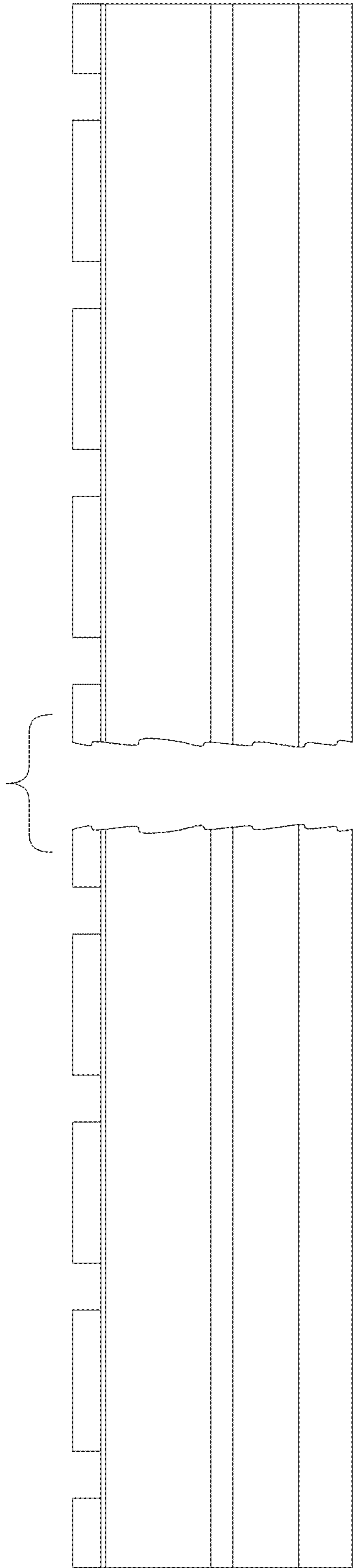

FIG. 25

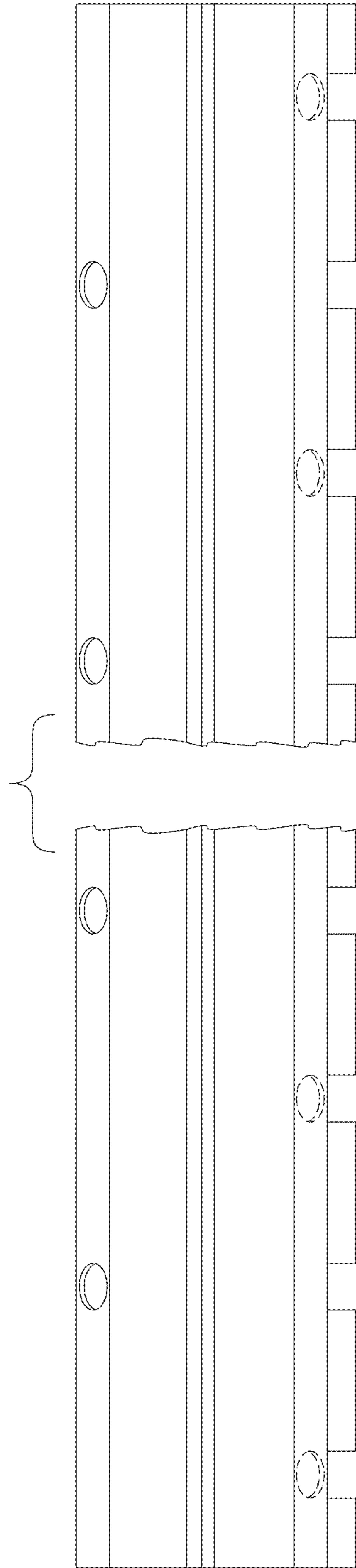

FIG. 26

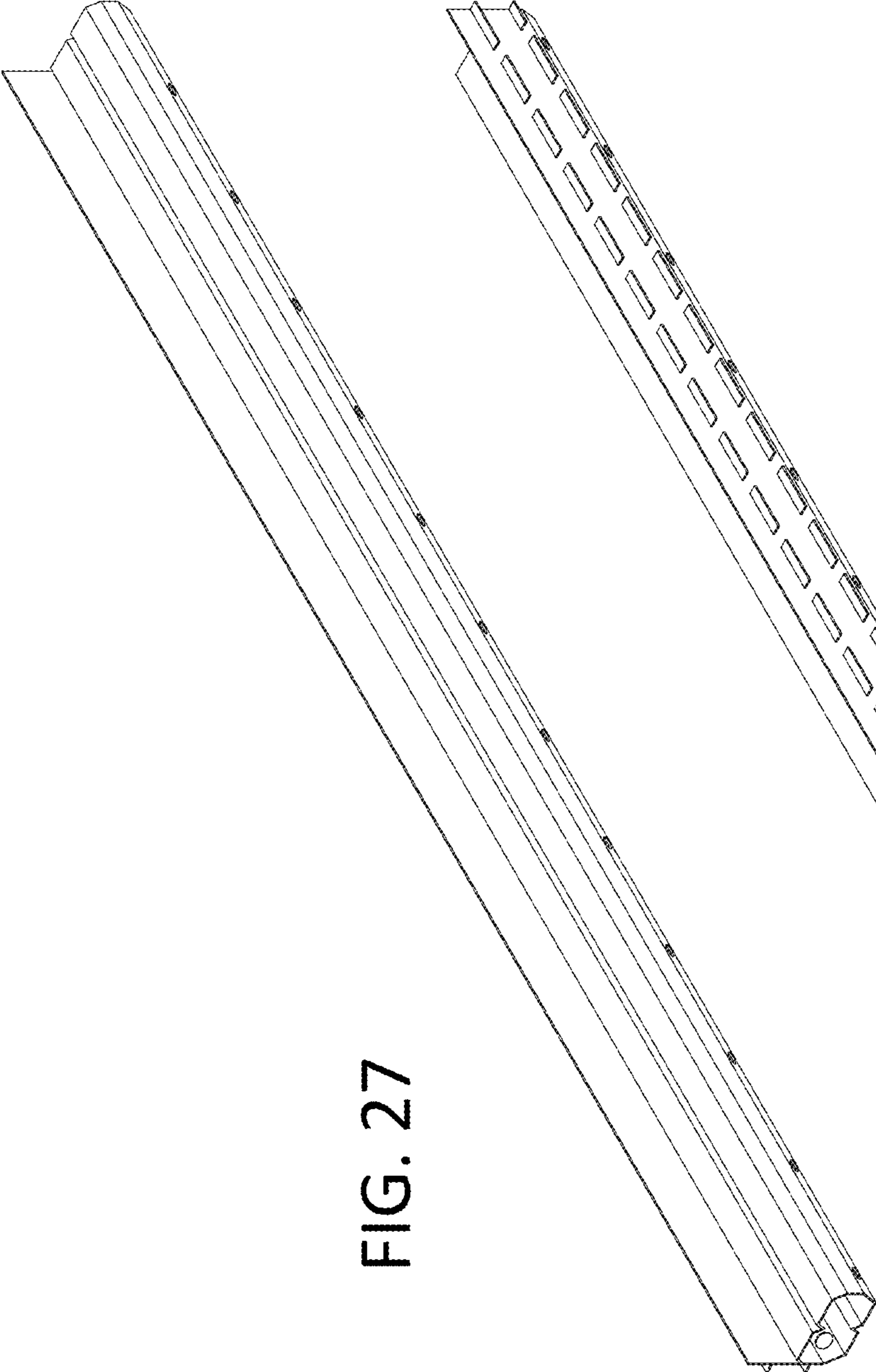

FIG. 27

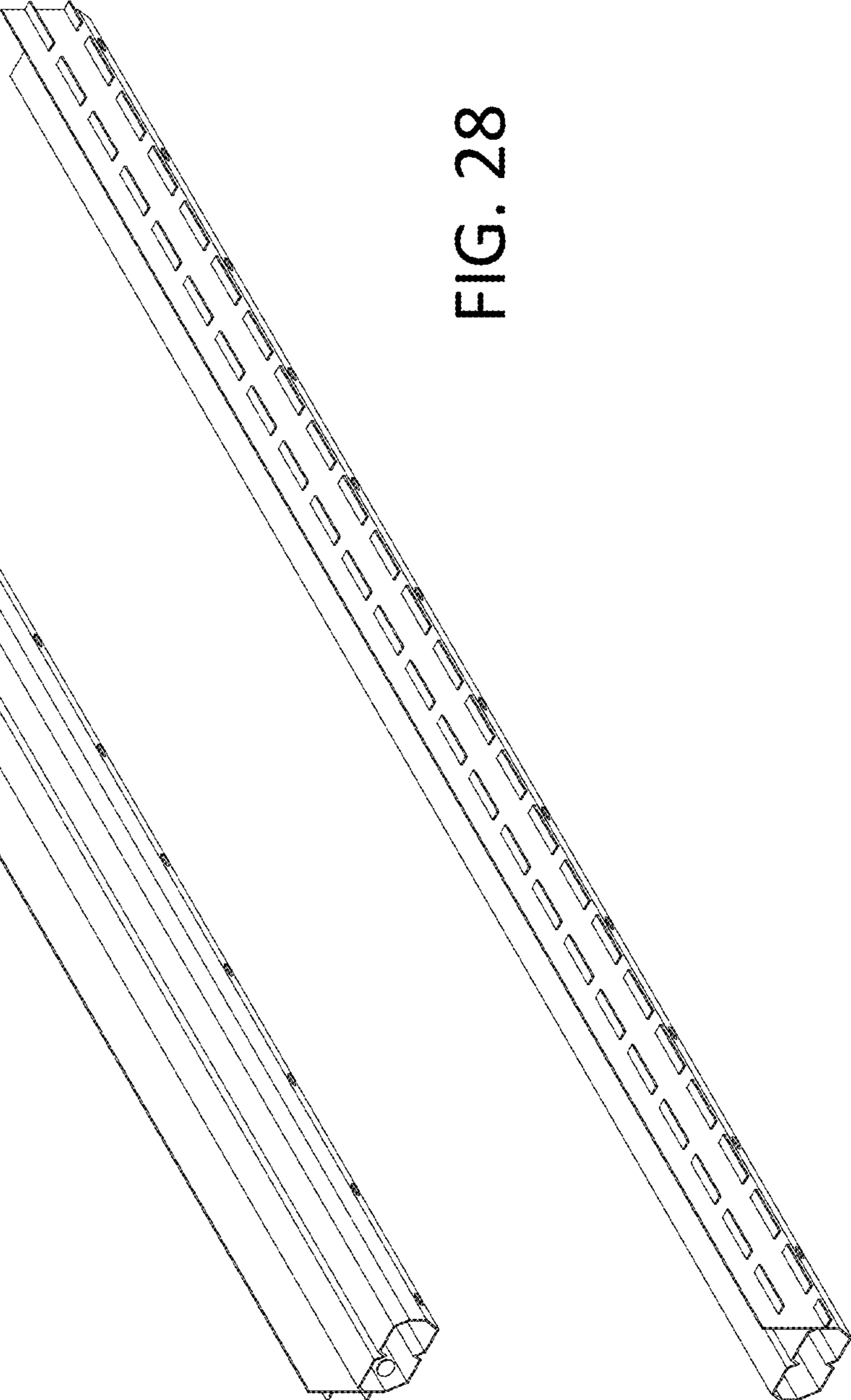

FIG. 28

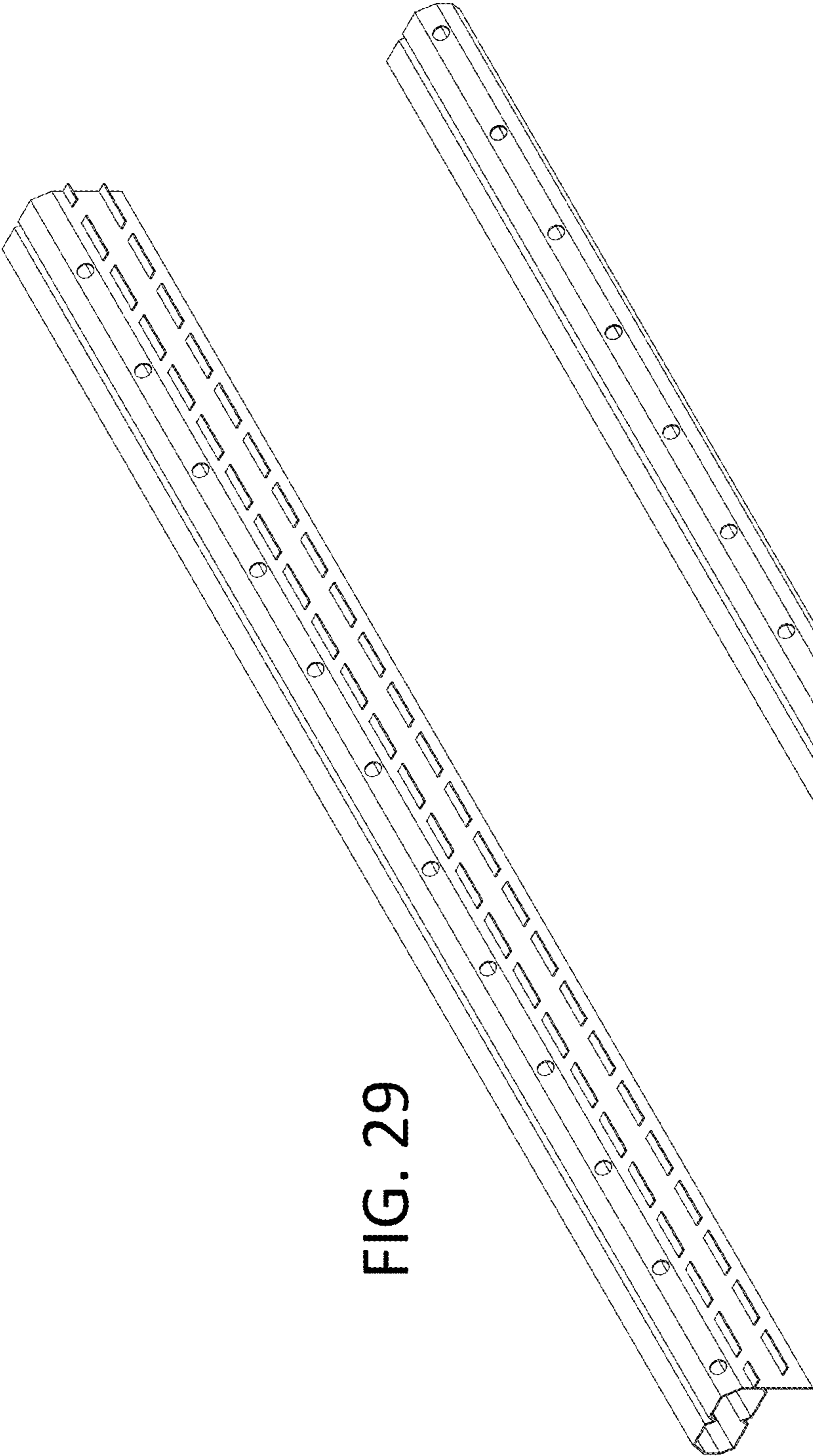

FIG. 29

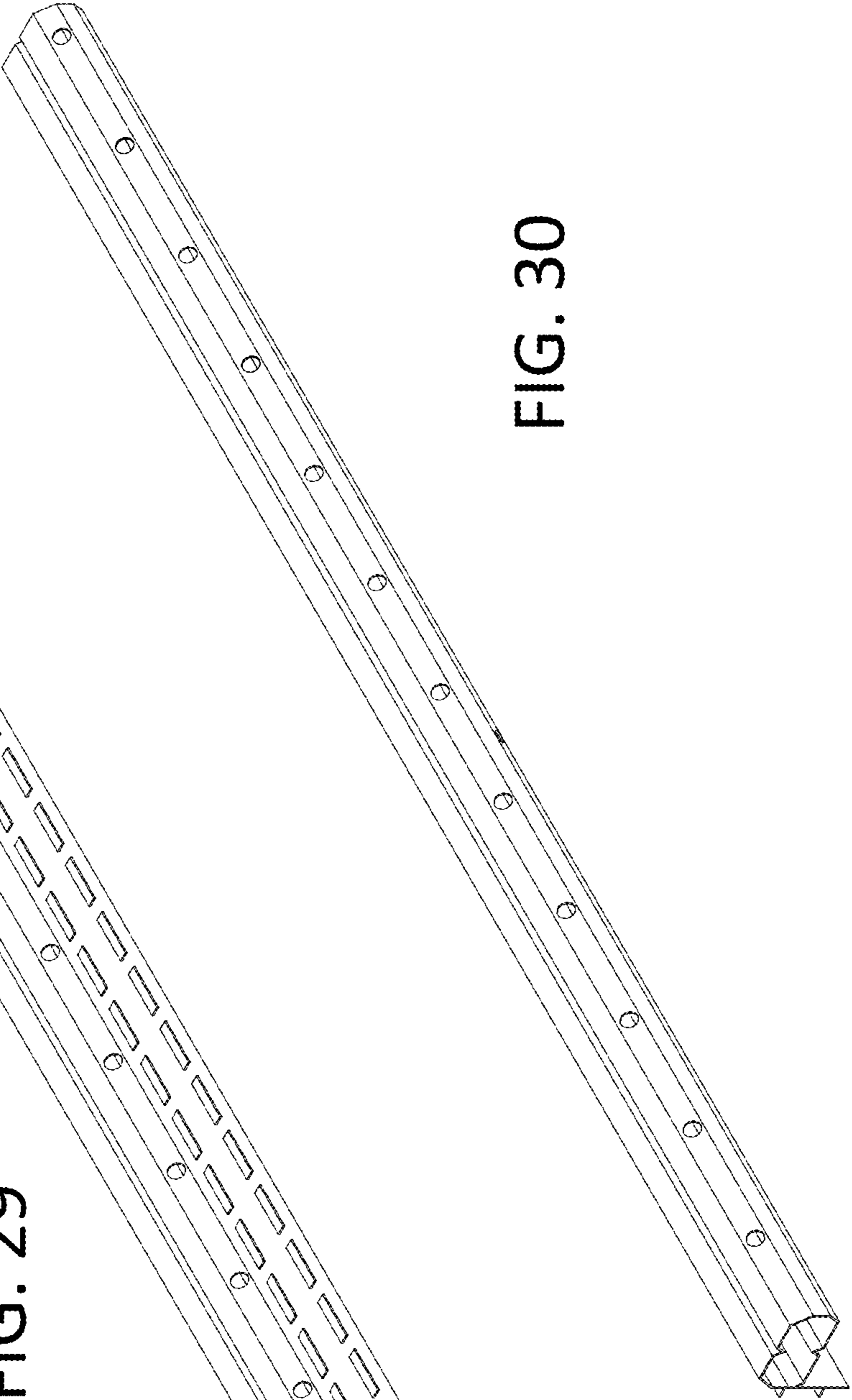

FIG. 30

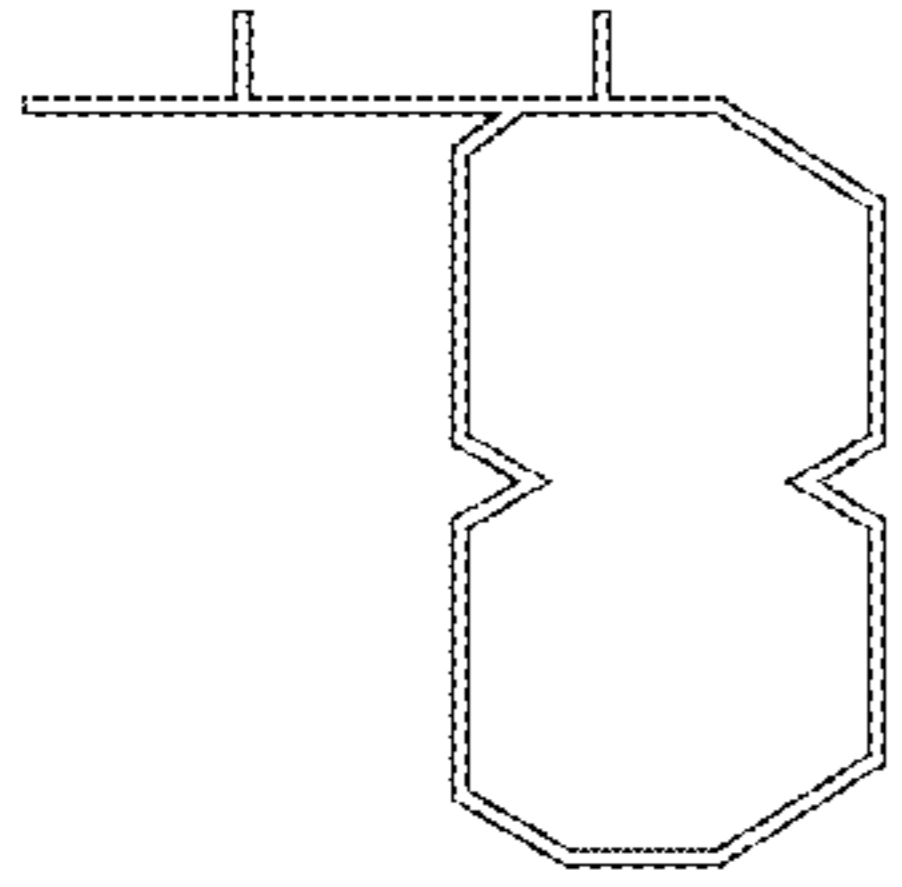

FIG. 31

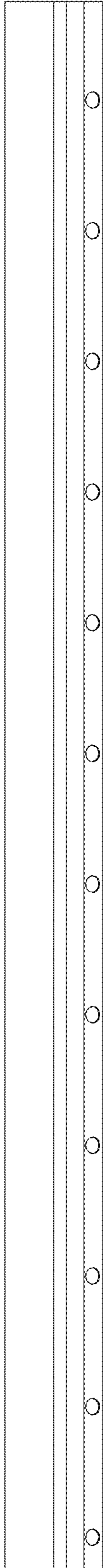

FIG. 32

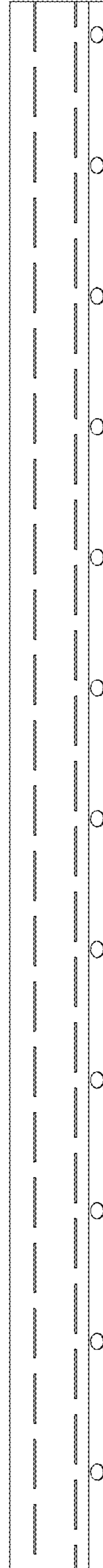

FIG. 33

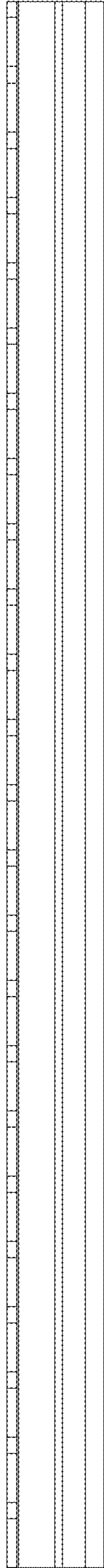

FIG. 34

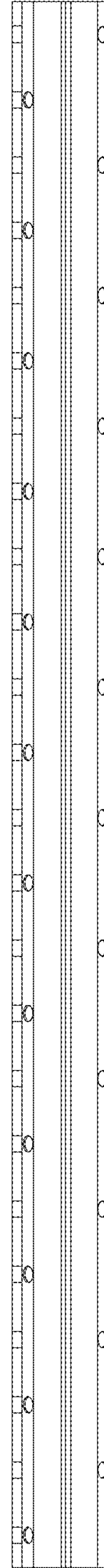

FIG. 35

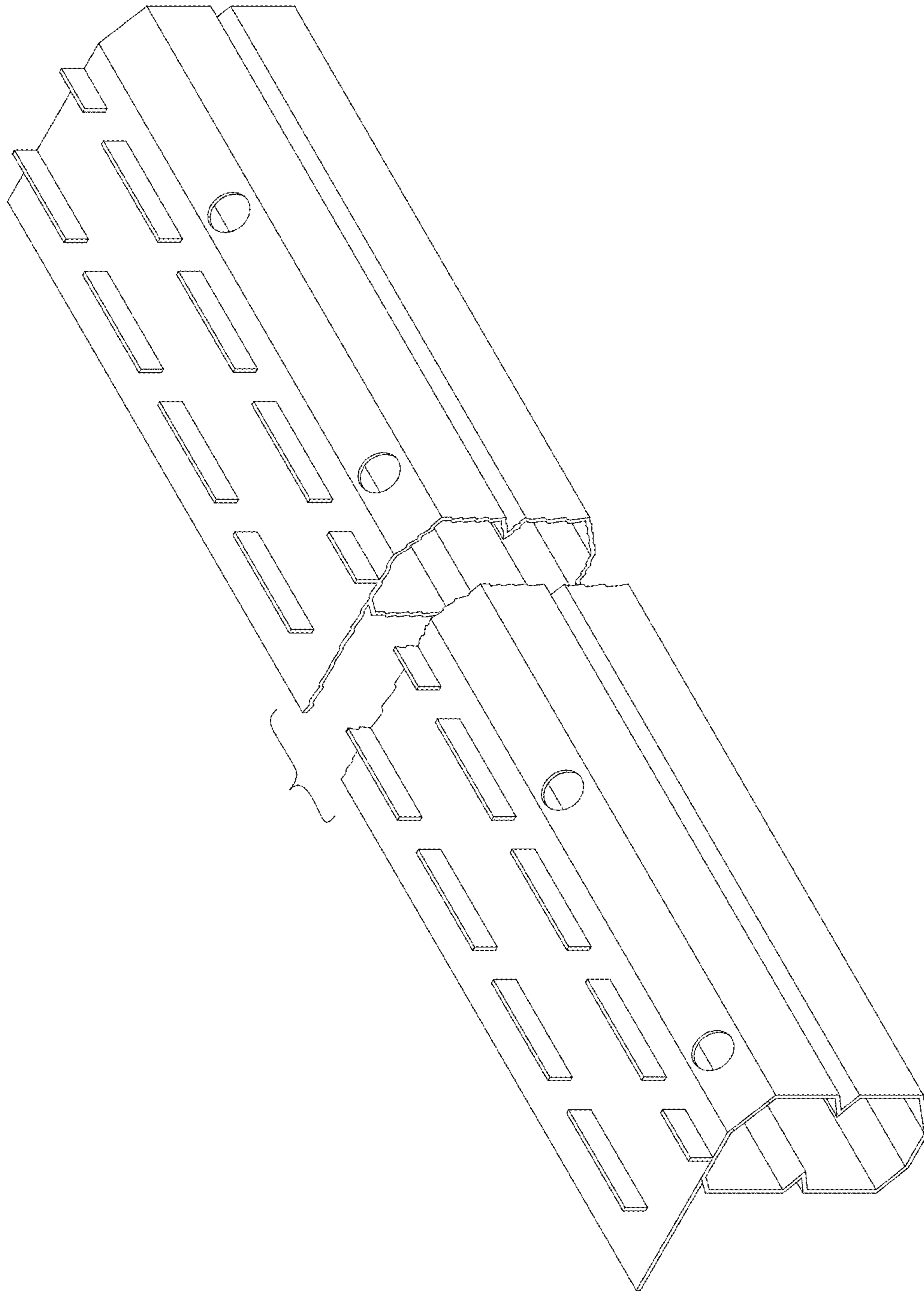

FIG. 36

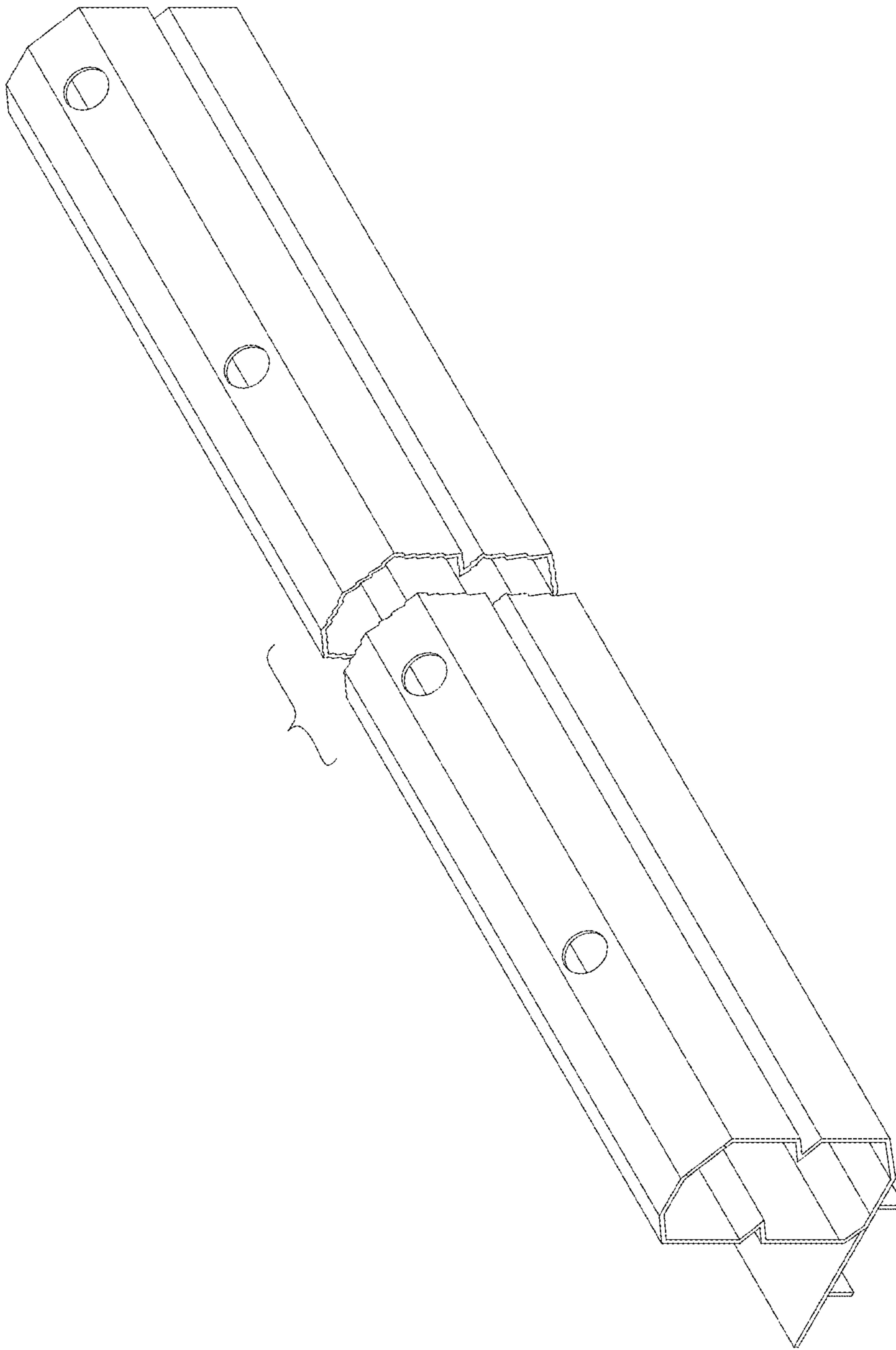

FIG. 37

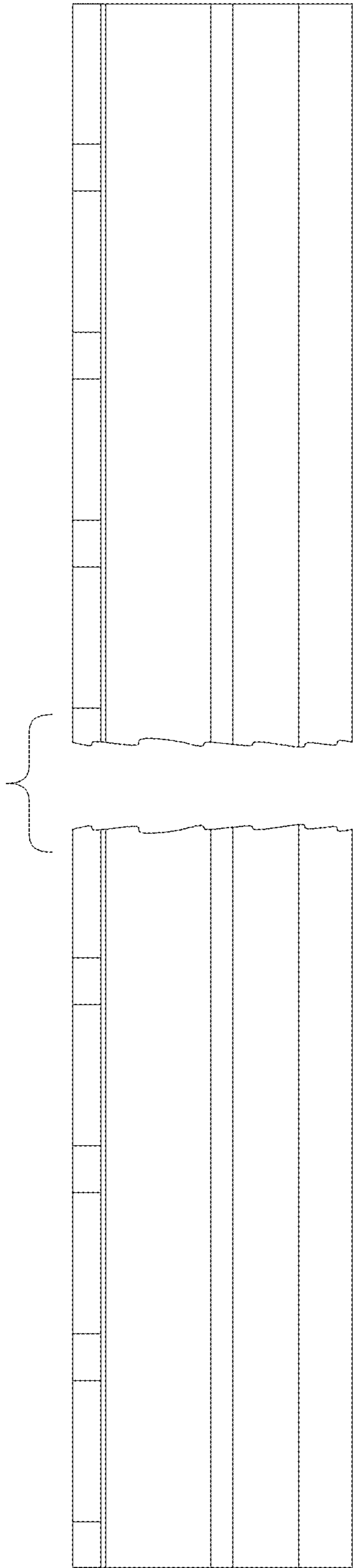

FIG. 38

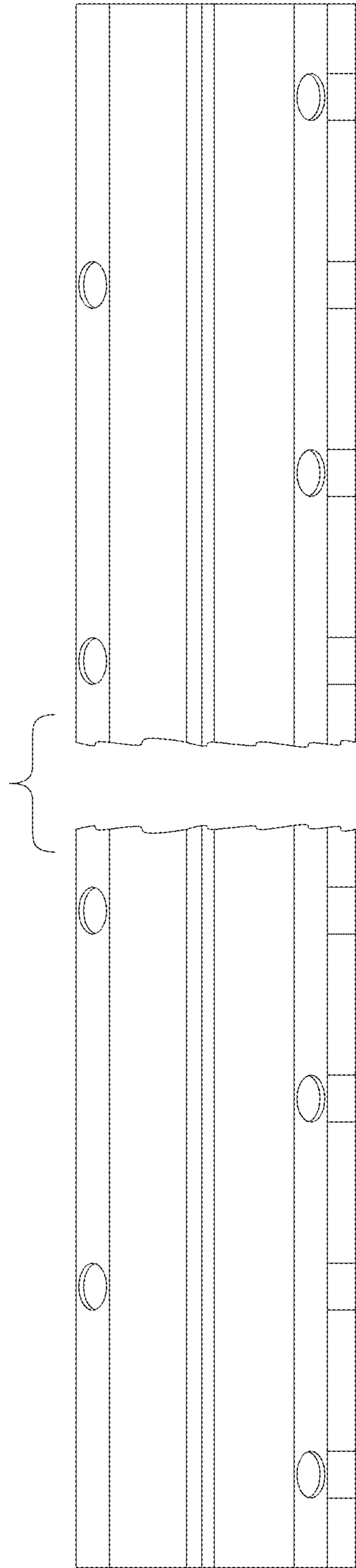

FIG. 39