



US00D911980S

(12) **United States Design Patent**  
**Sato et al.**

(10) **Patent No.:** **US D911,980 S**  
(45) **Date of Patent:** **\*\* Mar. 2, 2021**

(54) **CONNECTOR**

(71) Applicant: **Japan Aviation Electronics Industry, Limited**, Tokyo (JP)

(72) Inventors: **Yukiko Sato**, Tokyo (JP); **Kumpei Fujita**, Kyoto (JP)

(73) Assignee: **JAPAN AVIATION ELECTRONICS INDUSTRY, LIMITED**, Tokyo (JP)

(\*\*) Term: **15 Years**

(21) Appl. No.: **29/701,848**

(22) Filed: **Aug. 15, 2019**

(30) **Foreign Application Priority Data**

Feb. 15, 2019 (JP) ..... 2019-003043

(51) **LOC (13) Cl.** ..... **13-03**

(52) **U.S. Cl.**  
USPC ..... **D13/147**

(58) **Field of Classification Search**  
USPC ..... D13/103, 107, 108, 110, 112, 118, 120, D13/123, 133, 137.1, 145–147, 149–156, D13/158, 173, 177, 184, 199; D14/240, D14/242, 432–435, 435.1, 436–438  
CPC ..... H01R 13/506; H01R 13/6585  
See application file for complete search history.

(56) **References Cited**

**U.S. PATENT DOCUMENTS**

D772,167 S \* 11/2016 Tada ..... D13/147  
D775,083 S \* 12/2016 Tada ..... D13/147  
9,997,869 B2 \* 6/2018 Zhang ..... H01R 13/5202  
10,135,204 B2 \* 11/2018 Zhang ..... H01R 13/6593  
10,177,504 B2 \* 1/2019 Zhao ..... H01R 13/6594  
10,276,983 B2 \* 4/2019 Arai ..... H01R 43/24  
10,333,254 B2 \* 6/2019 Zhao ..... H01R 13/504  
10,411,413 B2 \* 9/2019 Feng ..... H01R 13/6585

10,454,221 B2 \* 10/2019 Naito ..... H01R 12/7005  
D867,301 S \* 11/2019 Saitou ..... D13/147  
10,468,824 B2 \* 11/2019 Lin ..... H01R 13/6585  
(Continued)

**FOREIGN PATENT DOCUMENTS**

JP 1556424 S 8/2016

**OTHER PUBLICATIONS**

Element 14. DV2P024M11E. No date specified. <https://sg.element14.com/japan-aviation-electronics-industry/dv2p024m11e/plug-free-dvi-d-24way/dp/9965181> (Year: 0).\*  
(Continued)

*Primary Examiner* — Darcey E Gottschalk  
(74) *Attorney, Agent, or Firm* — Manabu Kanesaka

(57) **CLAIM**

The ornamental design for a connector, as shown and described.

**DESCRIPTION**

FIG. 1 is a front elevational view of a connector showing our new design;  
FIG. 2 is a rear elevational view thereof;  
FIG. 3 is a right side elevational view thereof;  
FIG. 4 is a left side elevational view thereof;  
FIG. 5 is a top plan view thereof;  
FIG. 6 is a bottom plan view thereof;  
FIG. 7 is a perspective view showing a front, top and right side thereof;  
FIG. 8 is a perspective view showing a rear, bottom and left side thereof;  
FIG. 9 is a perspective view showing a front, right and bottom side thereof; and,  
FIG. 10 is a perspective view showing a rear, left and top side thereof.  
The broken line showing of the connector is for the purpose of illustrating portions of the article and forms no part of the claimed design.

**1 Claim, 5 Drawing Sheets**

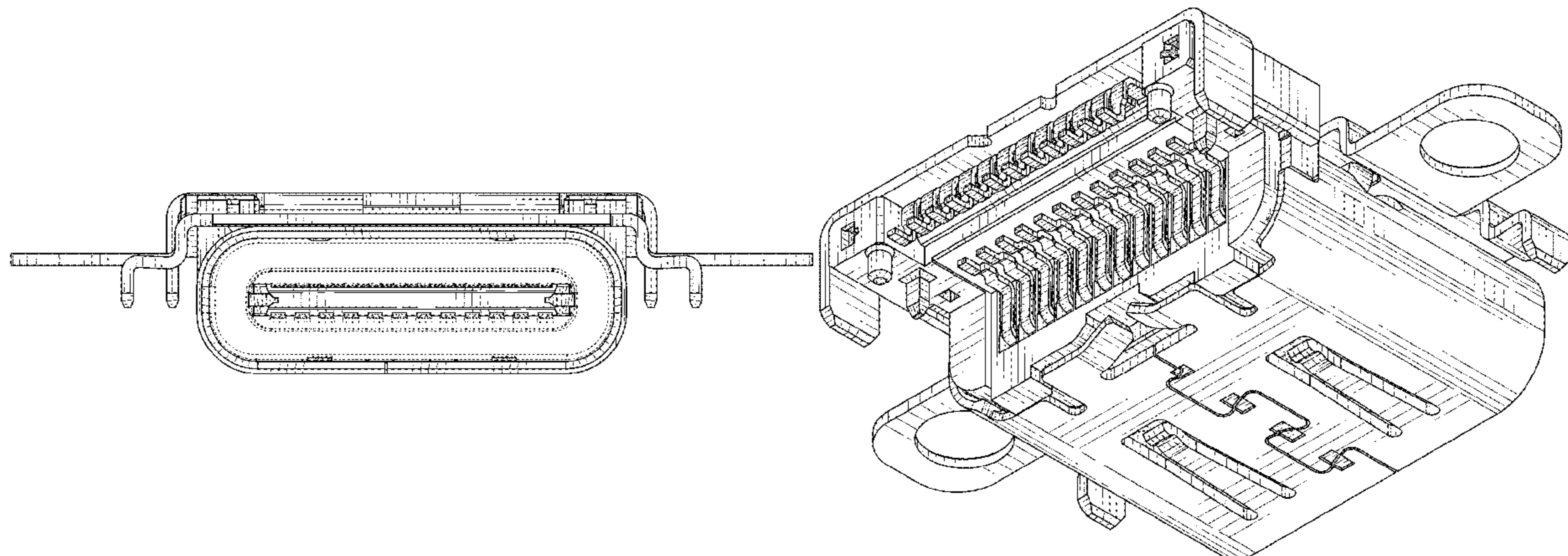

(56)

**References Cited**

U.S. PATENT DOCUMENTS

10,498,087 B2 \* 12/2019 Zhao ..... H01R 13/6582  
10,541,498 B2 \* 1/2020 Zhao ..... H01R 13/6585  
10,630,018 B1 \* 4/2020 Yang ..... H01R 12/55

OTHER PUBLICATIONS

Japan Aviation Electronics Industry. DX07BN24JA2R1300. No date specified. [https://www.jae.com/en/connectors/series/detail/product/id=66502&type\\_code=T1010](https://www.jae.com/en/connectors/series/detail/product/id=66502&type_code=T1010) (Year: 0).\*

Japan Patent Office, "Office Action for Japanese Design Application No. 2019-003043," dated Jun. 7, 2019.

\* cited by examiner

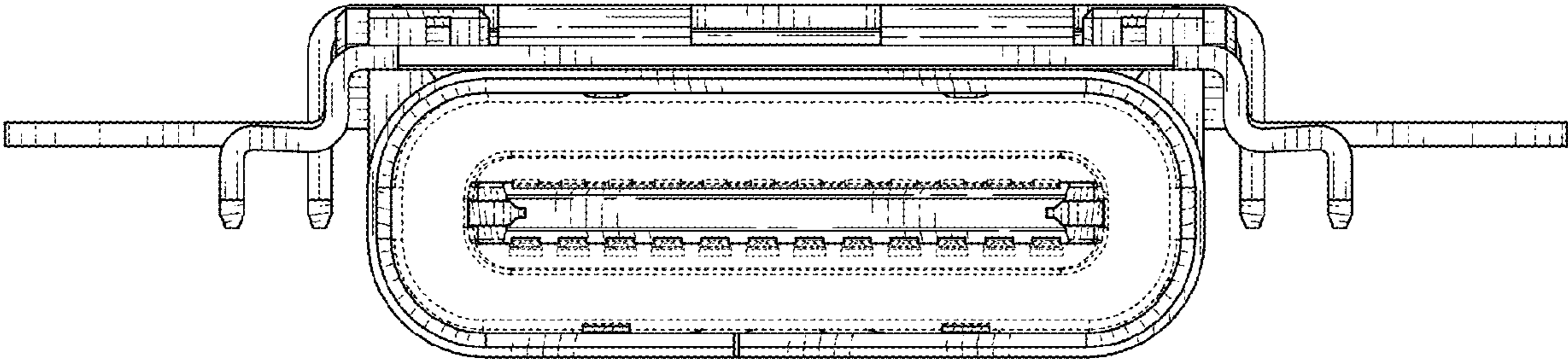

FIG. 1

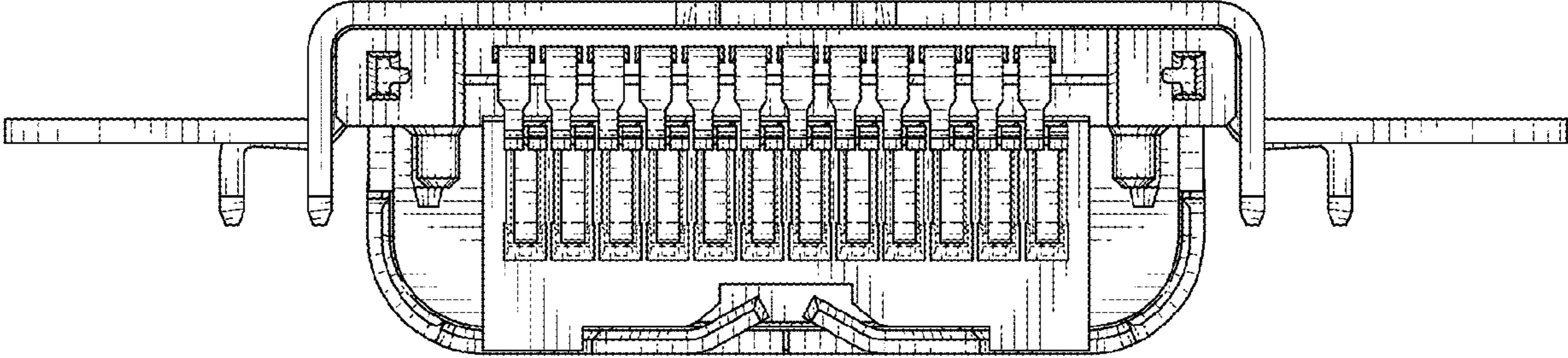

FIG. 2

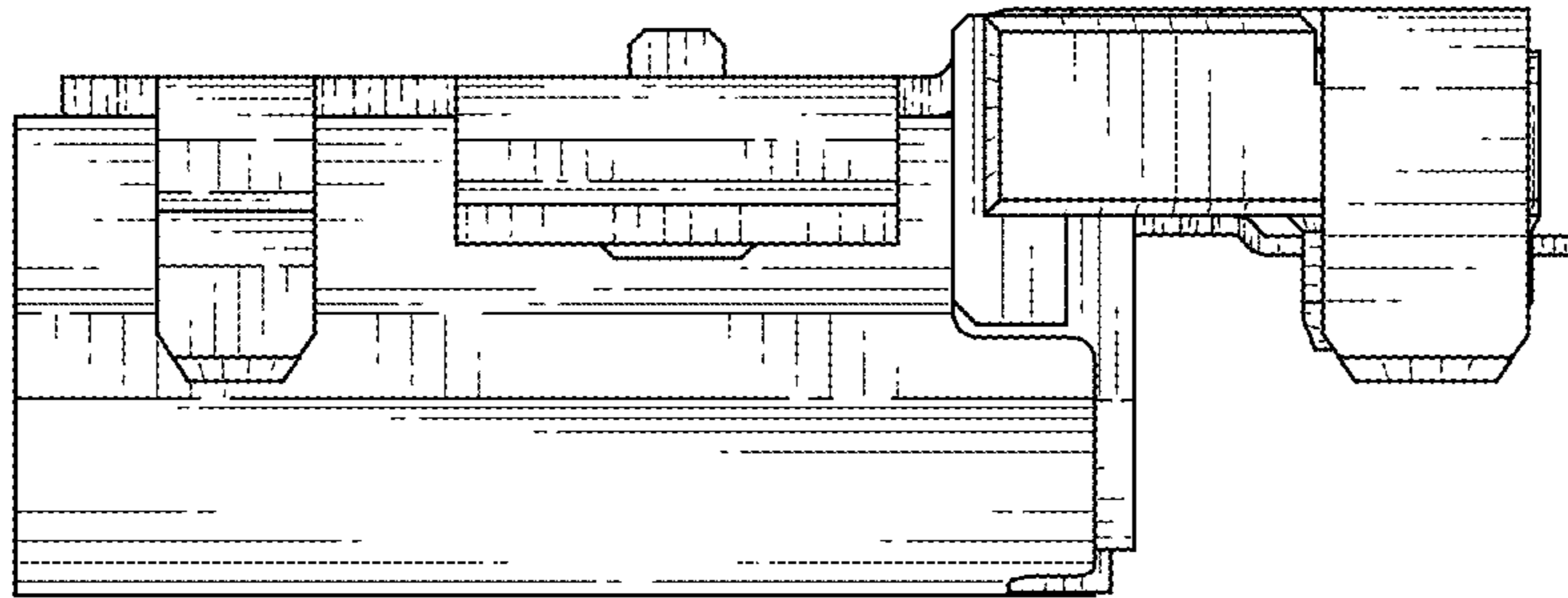

FIG. 3

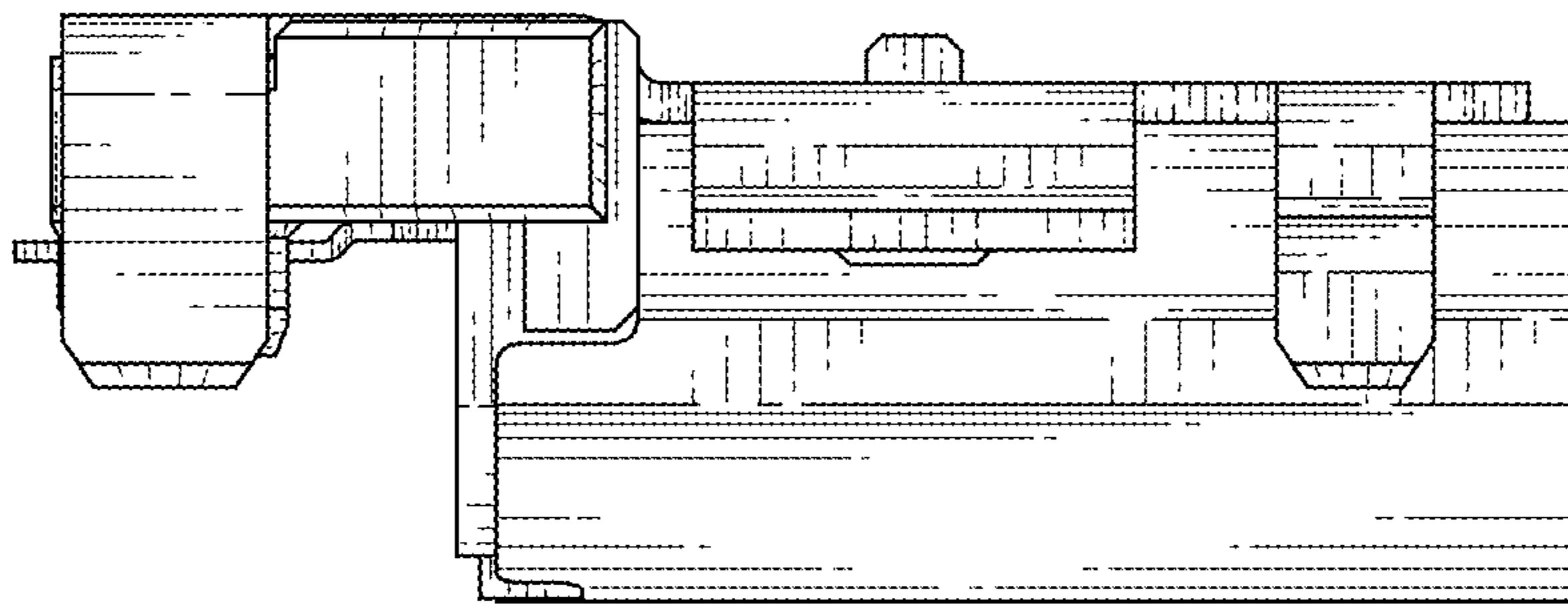

FIG. 4



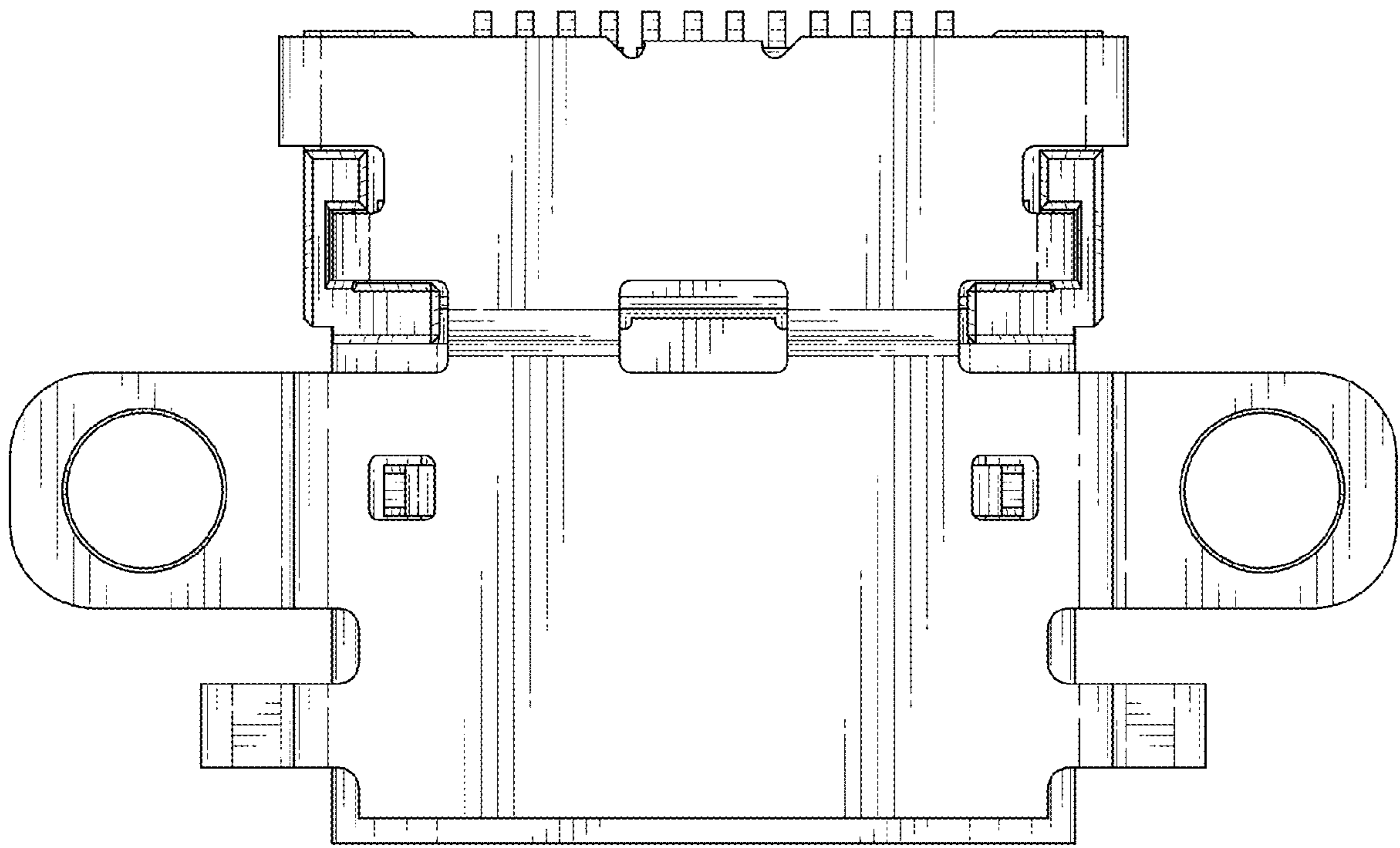

FIG. 5

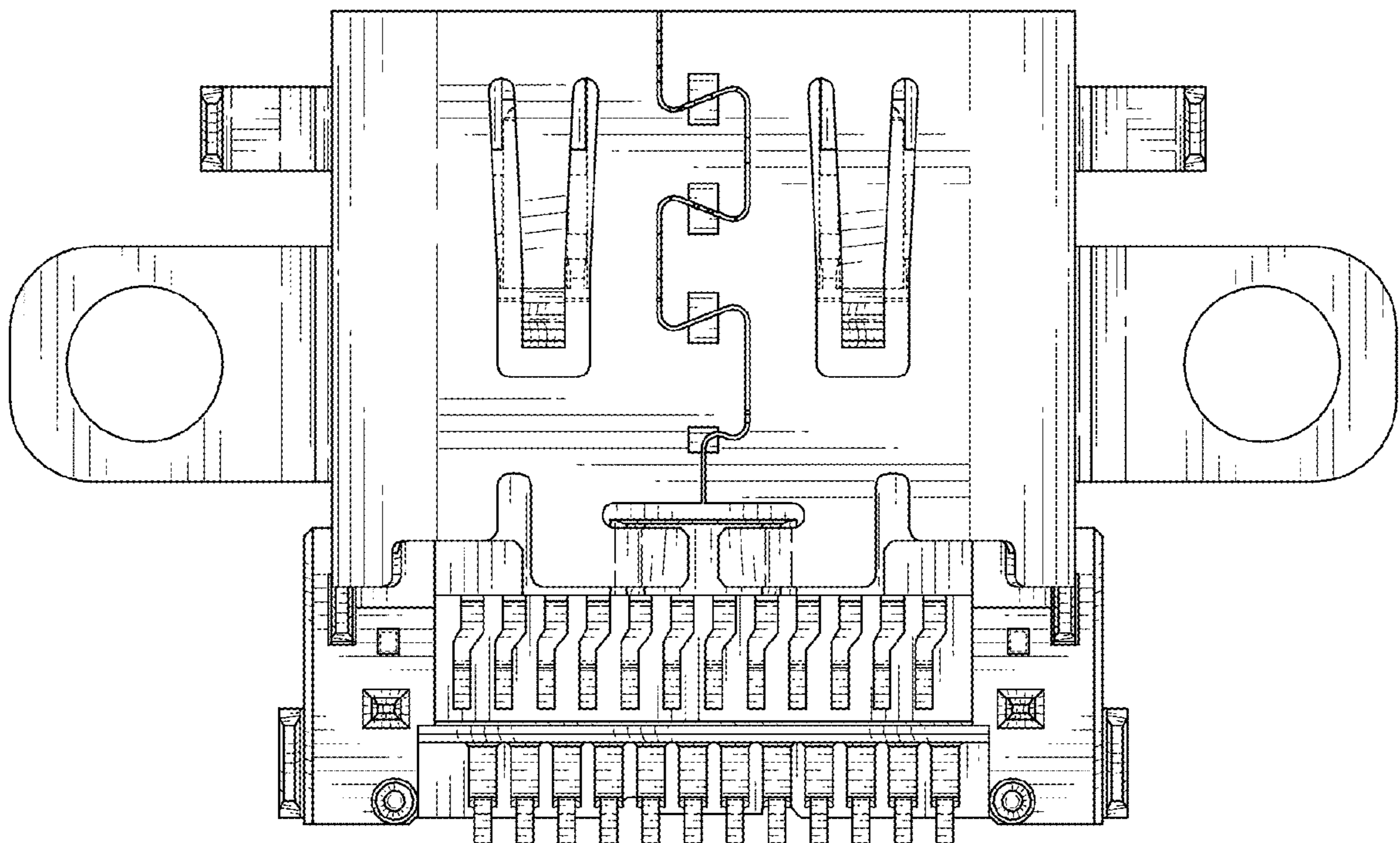

FIG. 6

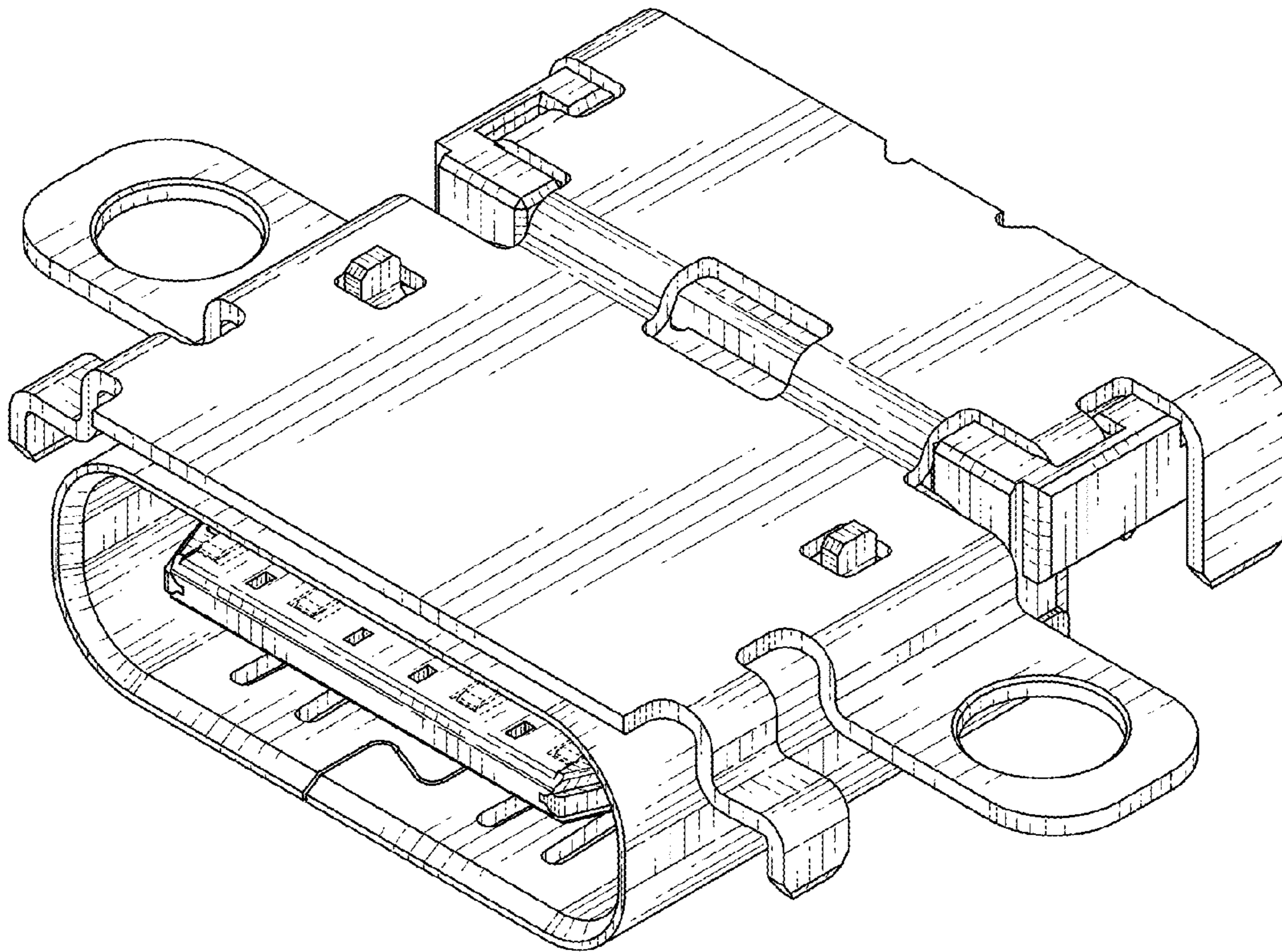

FIG. 7

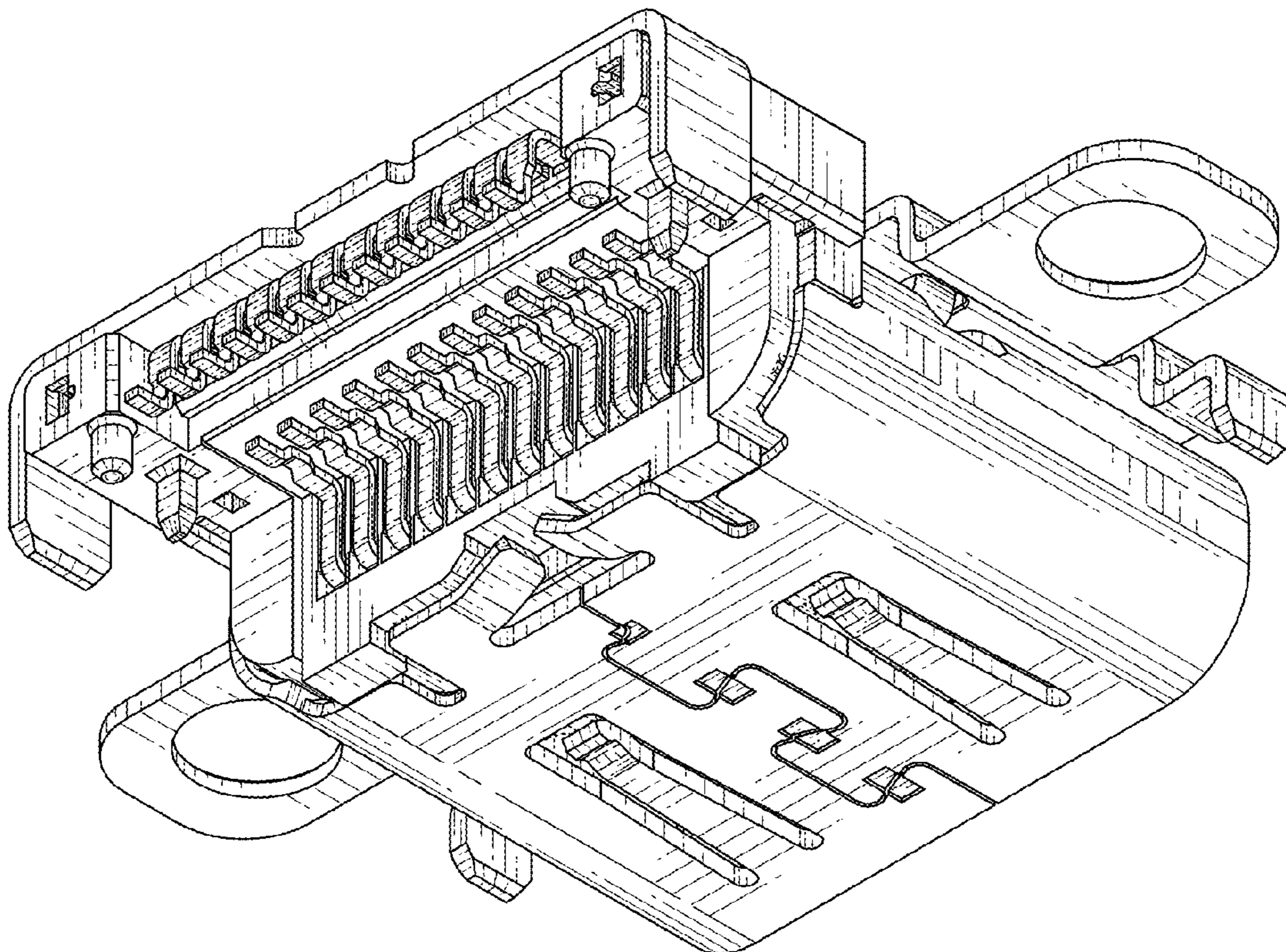

FIG. 8



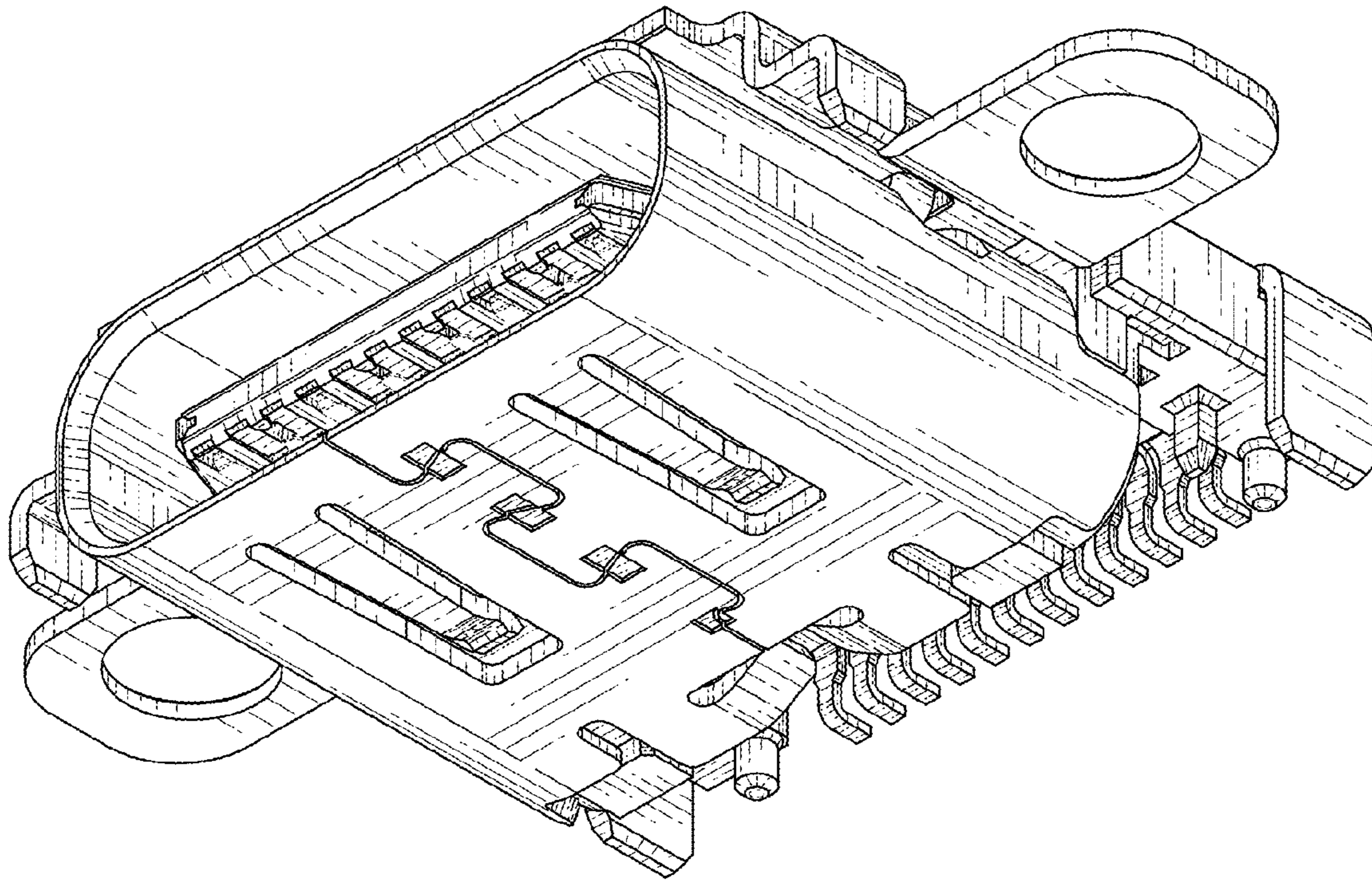

FIG. 9

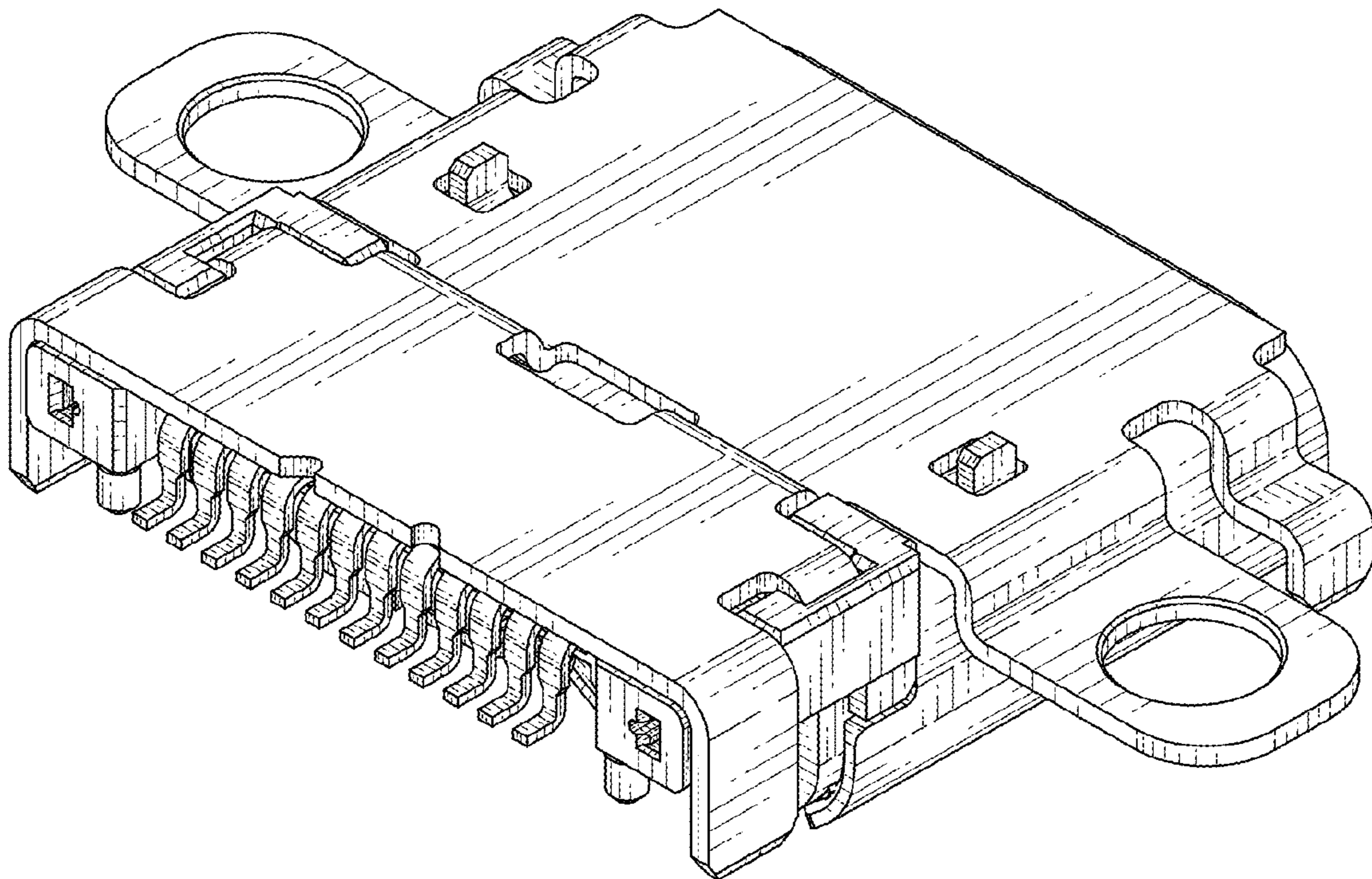

FIG. 10